

- 11 REMOVE WATER HEATER DOOR STRAPS AND HARDWARE.
- 10 SEAL VENT HOLE IN DOOR W/SILICONE SEALANT.
- 9. ALL CRIMP FITTINGS TO 3/4" PEX TUBING REQUIRE 3/4" CLAMP 140171-05-000.
- 8. ALL CRIMP FITTINGS TO 1/2" PEX TUBING REQUIRE 1/2" CLAMP 140171-03-000.
- 7. ALL CRIMP FITTINGS TO 5/8" FLEX TUBING REQUIRE 5/8" CLAMP 140171-04-000.
- 6 LABEL HOT AND COLD SUPPLY TUBES AND TAPE FITTING TO TUBE BEFORE CABINET SET TO PREVENT MOVEMENT.
- 5 ADD PIPE WRAP (LADDER SCRAP 110157-02-000) INSULATION.
- 4 ADD TEFLON TAPE 010405-02-000.
- 3. ALL TUBING TO BE SECURED AT 1200 INTERVALS MAXIMUM WITH CLAMP 010495-01-000 AND SCREW 000G67-10-12U OR EQUIVALENT.
- 2. TUBING TO BE INSTALLED WITH SUFFICIENT SLOPE TO PROVIDE DRAINAGE TO NEAREST VALVE.
- 1. PLASTIC FITTINGS TO BE SEALED WITH SEALANT 084456-01-000.

NOTES:

X-X  
FOR WATER CALLOUTS SEE DWG NO. 000209446 / 303369-01-000

<b>WINNEBAGO</b> <sup>®</sup>		COPYRIGHT 2024 WINNEBAGO INDUSTRIES, INC.	
DSNR:		ALL DIMENSIONS ARE IN MILLIMETERS	
DFTR:			
UNSPECIFIED TOLERANCES:		MATERIAL:	
WHOLE DIM (X) :	3		
ONE-PLACE (X.X) :	1.5		
TWO-PLACE (X.XX) :	0.50		
ANGLE :	1°		
REFER TO ES0018 FOR FASTENER TIGHTENING GUIDELINES		WEIGHT: (LBS)	FIRST USED: (REF)
			<b>17 730J</b>
<b>DESCRIPTION:</b>			
<b>WATER SYSTEM INSTL</b>			
SHEET:	ITEM/PART NO.:	REV	
<b>1 OF 3</b>	<b>000017773 / 31372901000</b>		
REF:		1 30-Jan-2024	

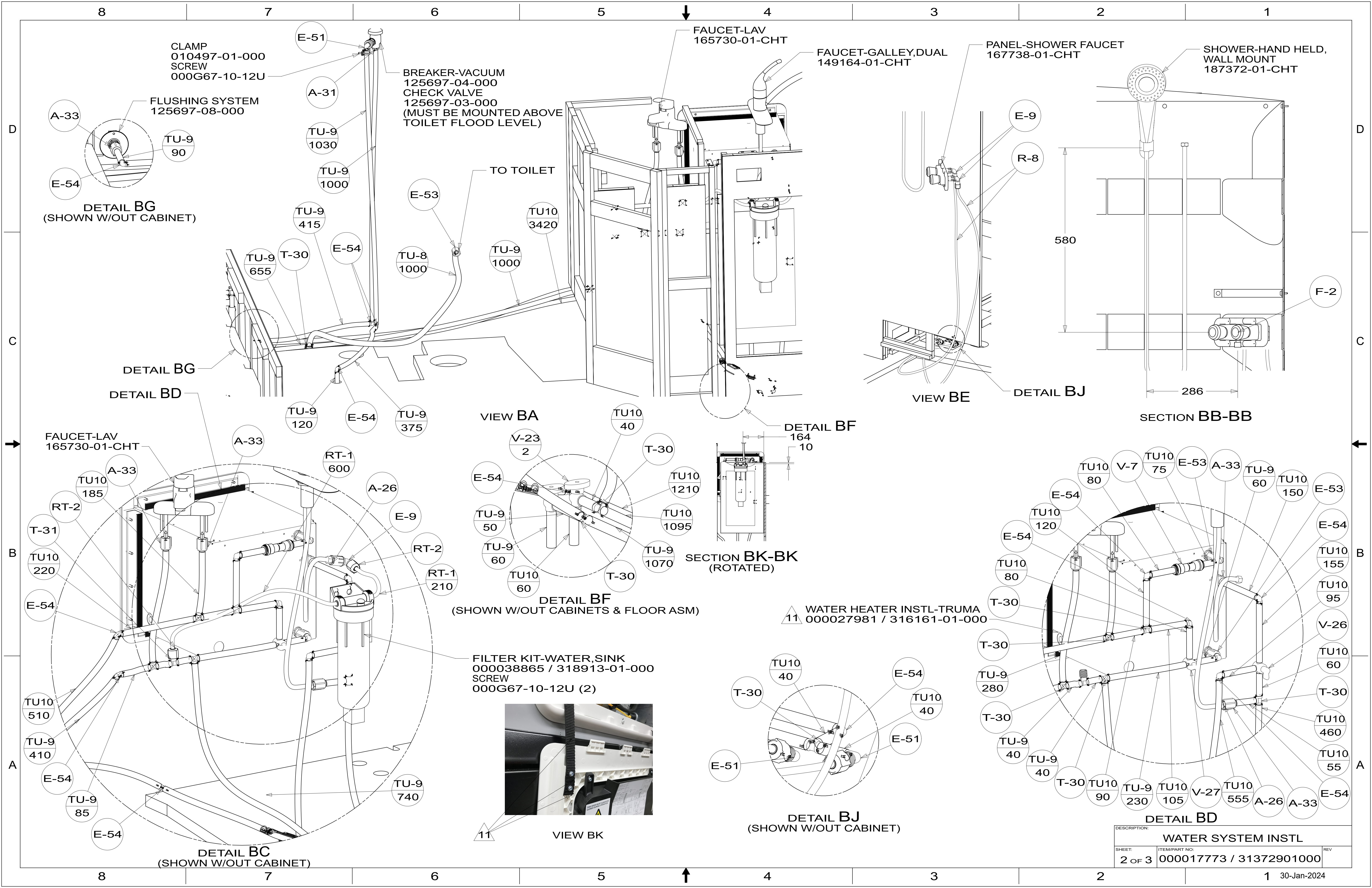

DESCRIPTION:		
WATER SYSTEM INSTL		
SHEET:	ITEM/PART NO.:	REV:
2 OF 3	000017773 / 31372901000	

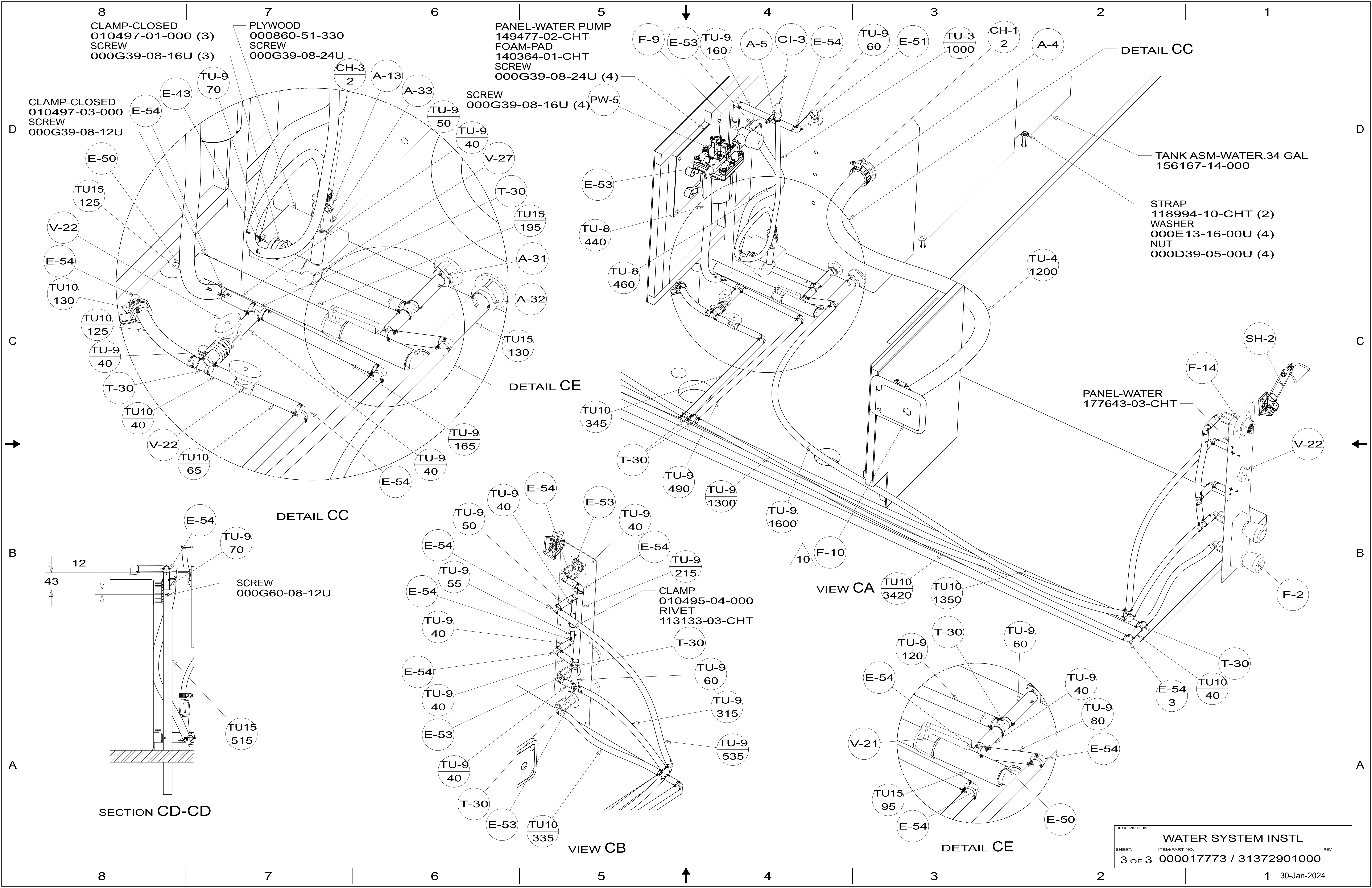

CLAMP-CLOSED  
010497-01-000 (3)  
SCREW  
000G39-08-16U (3)

PLYWOOD  
000860-51-330  
SCREW  
000G39-08-24U

PANEL-WATER PUMP  
149477-02-CHT  
FOAM-PAD  
140364-01-CHT  
SCREW  
000G39-08-24U (4)

CLAMP-CLOSED  
010497-03-000  
SCREW  
000G39-08-12U

SCREW  
000G39-08-16U (4)

DETAIL CC

TANK ASM-WATER,34 GAL  
156167-14-000

STRAP  
118994-10-CHT (2)  
WASHER  
000E13-16-00U (4)  
NUT  
000D39-05-00U (4)

PANEL-WATER  
177643-03-CHT

DETAIL CC

12  
43  
SCREW  
000G60-08-12U

CLAMP  
010495-04-000  
RIVET  
113133-03-CHT

VIEW CA

SECTION CD-CD

VIEW CB

DETAIL CE

DESCRIPTION: WATER SYSTEM INSTL		
SHEET: 3 OF 3	ITEM/PART NO: 000017773 / 31372901000	REV