

SWITCH-WATER PUMP  
108357-21-000  
ACTUATOR  
108356-03-CHT  
(CIRCUITS JA,JY,  
XXZ,YYF)

SWITCH-AUTO LEVEL  
108357-18-000  
ACTUATOR  
108356-03-CHT  
(CIRCUITS SSD,SSE,  
SSC,SSE,SSF)

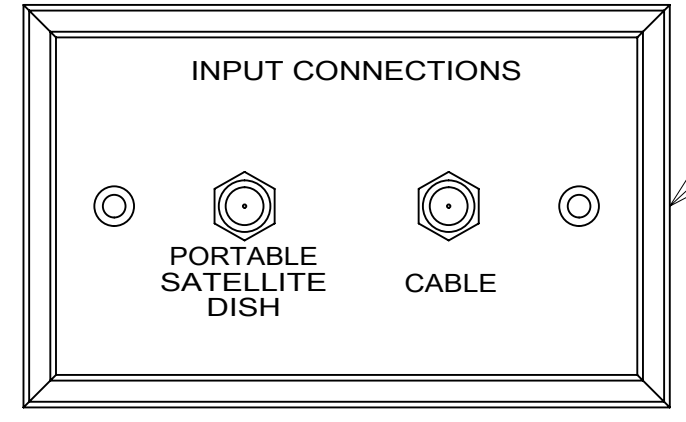
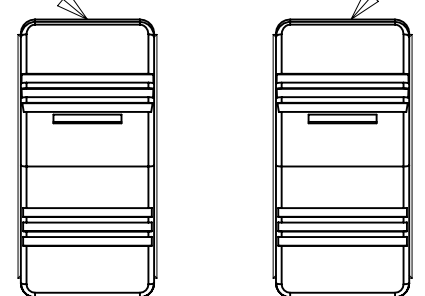
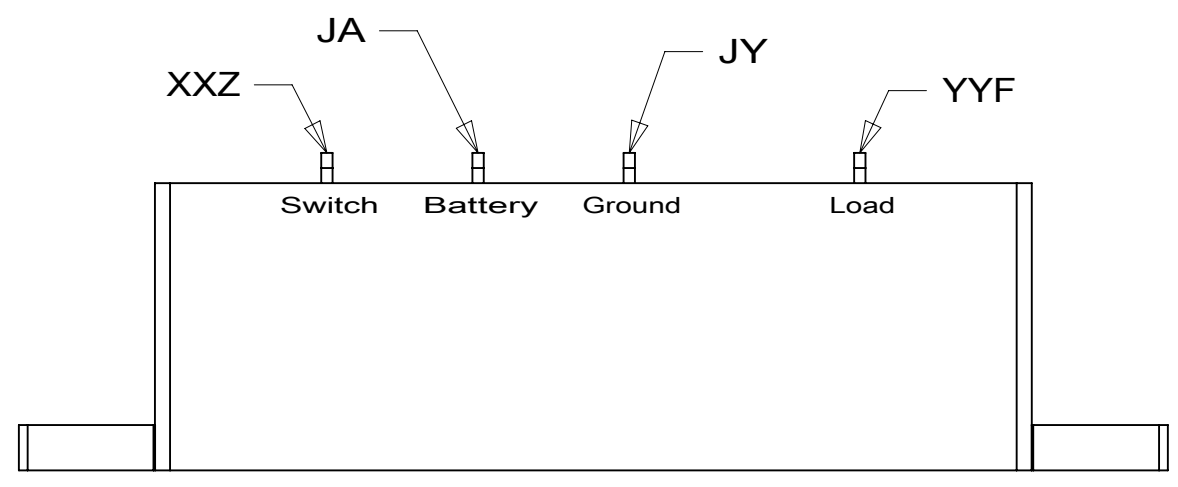
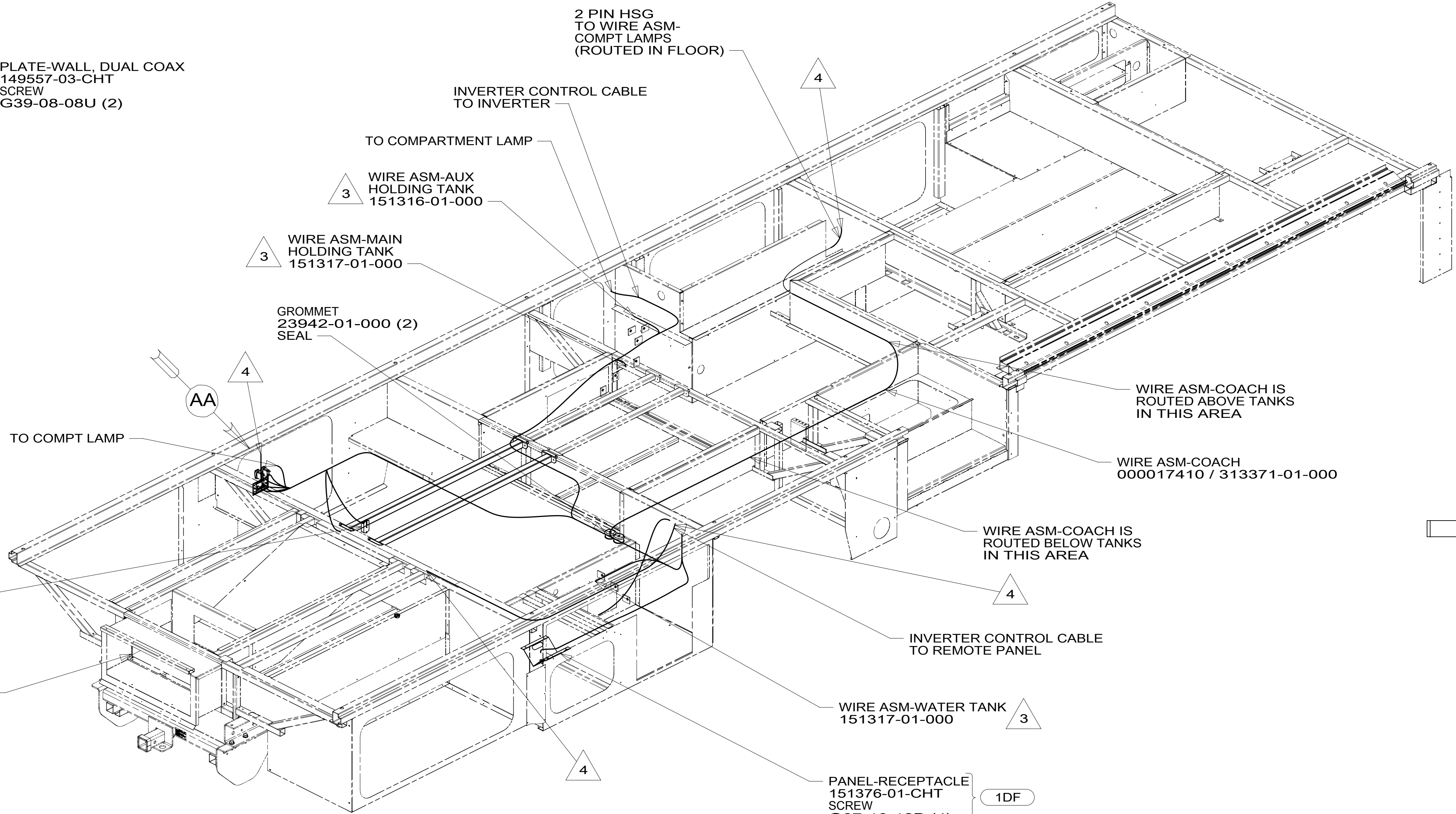

PLATE-WALL, DUAL COAX  
149557-03-CHT  
SCREW  
G39-08-08U (2)

VIEW AA



DETAIL AB

- PANEL-RECEPTACLE 151376-01-CHT SCREW G67-10-12B (4)
- PANEL-RECEPTACLE 151376-02-CHT LABEL-COAX 157486-01-CHT ADAPTER 82134-01-000 NUT 82136-01-000 SCREW G67-10-12B (4)

1DF

299

- 4 WIRE PASSES THROUGH FLOOR IN THIS AREA.
- 3 PLACE CROSS LOCATOR ON SENSOR OVER DIMPLES ON TANK.

2. ROUTE TANK SENSOR WIRES SO THEY DO NOT PASS OVER SENSORS. USE WIRE TIE MOUNT 155366-01-000 AND WIRE TIE 8343-01-000 AS NEEDED. TANK SURFACE MUST BE CLEANED USING ISOPROPYL ALCOHOL AND PRIMED WITH PRIMER 94.

1. AT MINIMUM ALL WIRES TO BE SUPPORTED AND SECURED PER CODE REQUIREMENTS. USE CLAMP 10495 OR 10497 OR WIRE TIE 8343 OR 108046 AND SCREW G67-XX-XXX OR G56-XX-XXX AS APPROPRIATE FOR INSTALLATION.

NOTES:

- 1DF EXT TV ENTERTAINMENT CENTER
- 299 ENTERTAINMENT CENTER EXT.W/O
- 265 CODES/STANDARDS-CSA/CMVSS
- 1B1 CODES/STANDARDS USA

**WINNEBAGO**  
COPYRIGHT 2016 WINNEBAGO INDUSTRIES, INC.

DSNR:	ALL DIMENSIONS ARE IN MILLIMETERS
DFFR:	
UNSPECIFIED TOLERANCES:	MATERIAL:
WHOLE DIM (X) : 3	
ONE-PLACE (X.X) : 1.5	
TWO-PLACE (X.XX) : 0.50	
ANGLE : 1°	
REFER TO ES0018 FOR FASTENER TIGHTENING GUIDELINES	WEIGHT: (LBS) FIRST USED: 17 D33C
DESCRIPTION: <b>WIRING INSTL-BODY, 12V</b>	
SHEET: 1 OF 7	ITEM/PART NO: 000016444 / 31316201000
REF:	REV: 1 20-Nov-2017

FOR ELECTRICAL TORQUE SPECIFICATIONS SEE DWG NO. 128783-01-000

FOR ELECTRICAL CALLOUTS SEE DWG NO. 121339-01-000

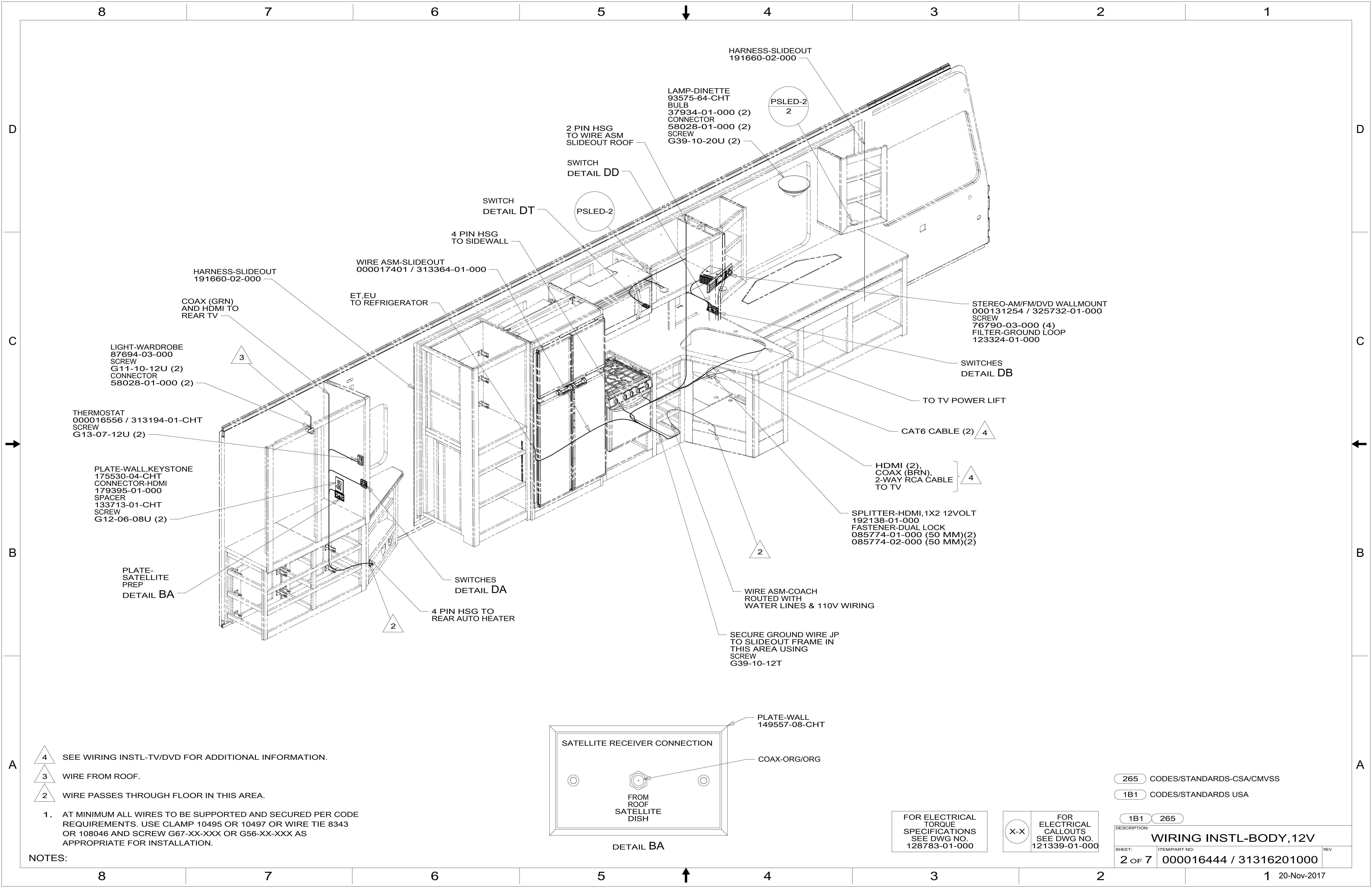

- 4 SEE WIRING INSTL-TV/DVD FOR ADDITIONAL INFORMATION.
- 3 WIRE FROM ROOF.
- 2 WIRE PASSES THROUGH FLOOR IN THIS AREA.

1. AT MINIMUM ALL WIRES TO BE SUPPORTED AND SECURED PER CODE REQUIREMENTS. USE CLAMP 10495 OR 10497 OR WIRE TIE 8343 OR 108046 AND SCREW G67-XX-XXX OR G56-XX-XXX AS APPROPRIATE FOR INSTALLATION.

NOTES:

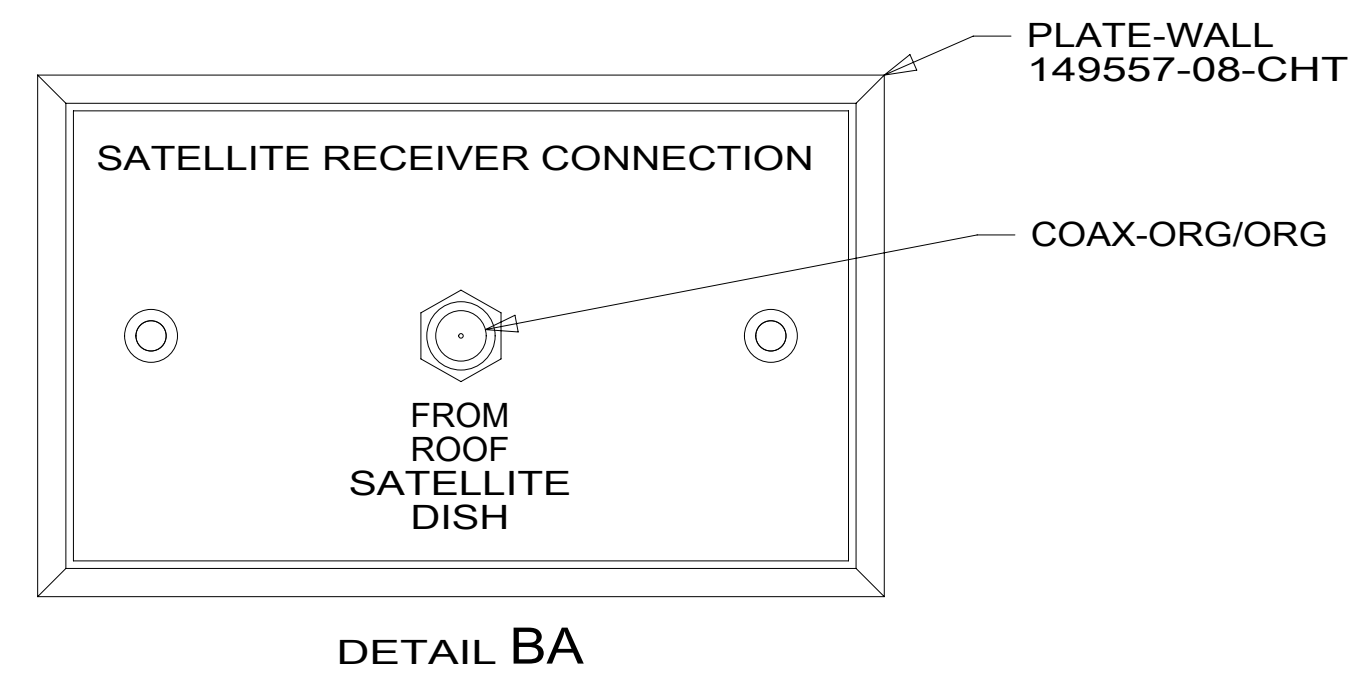

FOR ELECTRICAL TORQUE SPECIFICATIONS SEE DWG NO. 128783-01-000

FOR ELECTRICAL CALLOUTS SEE DWG NO. 121339-01-000

265 CODES/STANDARDS-CSA/CMVSS  
1B1 CODES/STANDARDS USA

DESCRIPTION:		1B1 265	
<b>WIRING INSTL-BODY, 12V</b>			
SHEET:	ITEM/PART NO.:	REV:	
2 OF 7	000016444 / 31316201000		

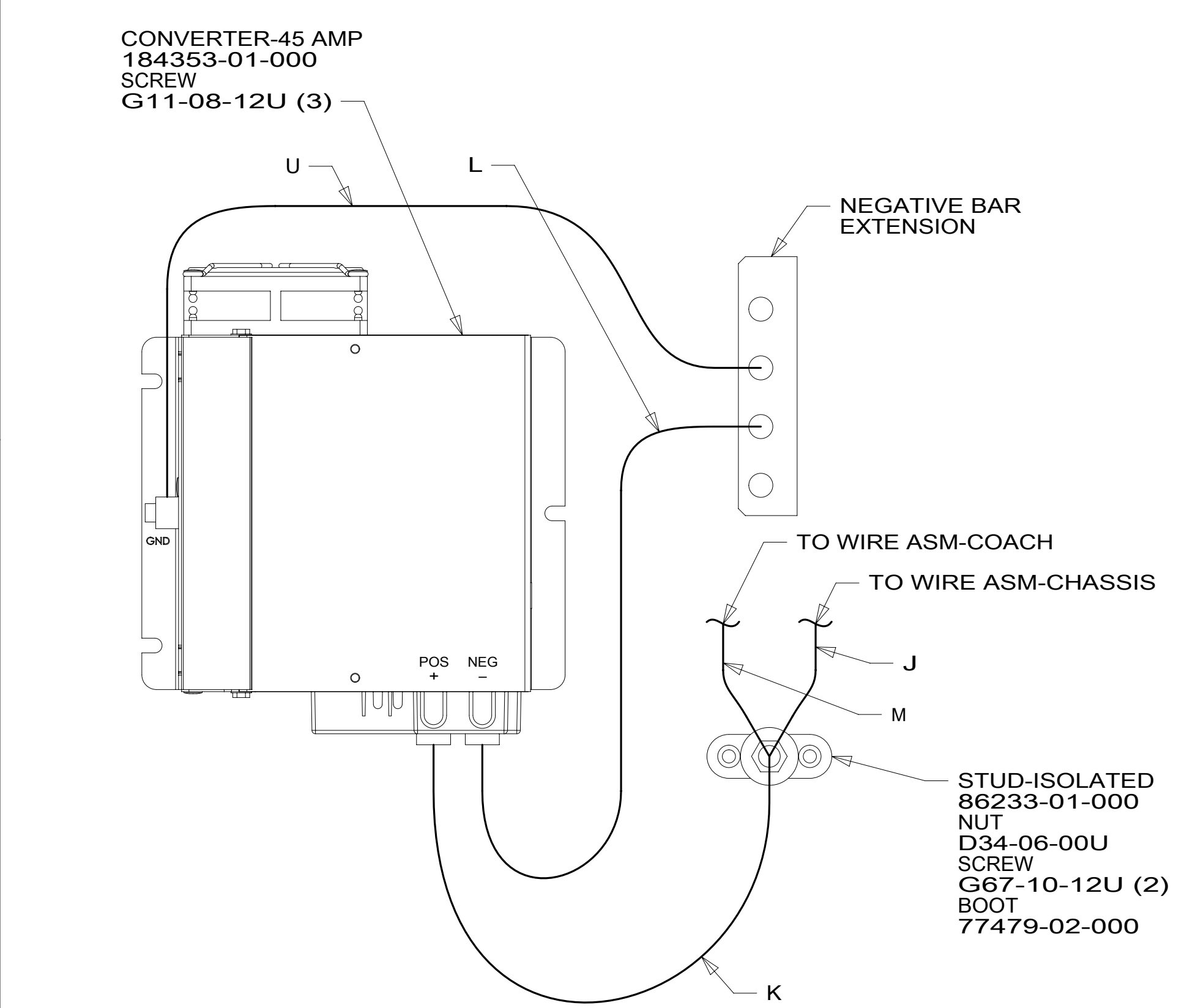
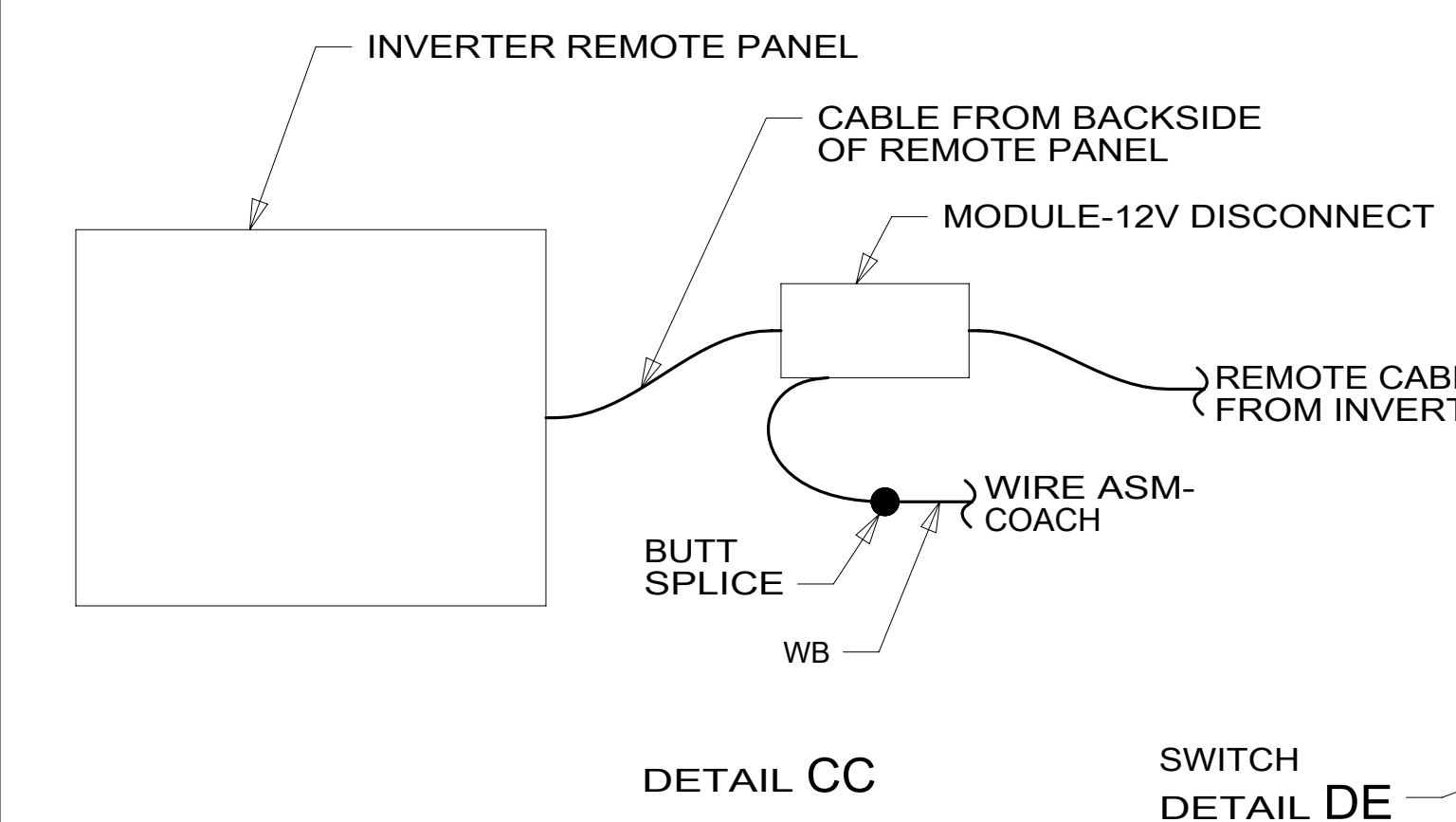
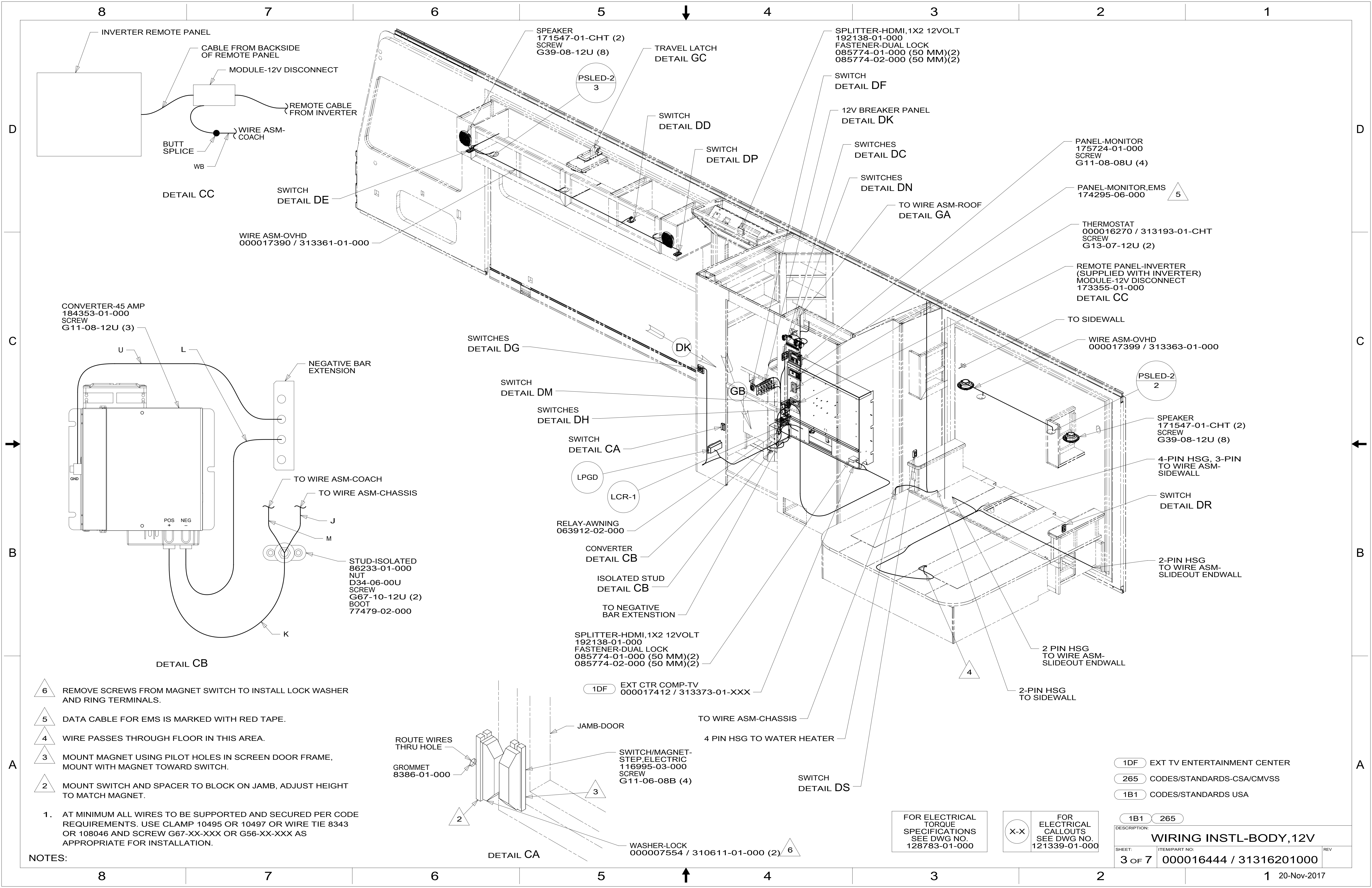

- NOTES:
- 1. AT MINIMUM ALL WIRES TO BE SUPPORTED AND SECURED PER CODE REQUIREMENTS. USE CLAMP 10495 OR 10497 OR WIRE TIE 8343 OR 108046 AND SCREW G67-XX-XXX OR G56-XX-XXX AS APPROPRIATE FOR INSTALLATION.
  - 2. MOUNT SWITCH AND SPACER TO BLOCK ON JAMB, ADJUST HEIGHT TO MATCH MAGNET.
  - 3. MOUNT MAGNET USING PILOT HOLES IN SCREEN DOOR FRAME, MOUNT WITH MAGNET TOWARD SWITCH.
  - 4. WIRE PASSES THROUGH FLOOR IN THIS AREA.
  - 5. DATA CABLE FOR EMS IS MARKED WITH RED TAPE.
  - 6. REMOVE SCREWS FROM MAGNET SWITCH TO INSTALL LOCK WASHER AND RING TERMINALS.

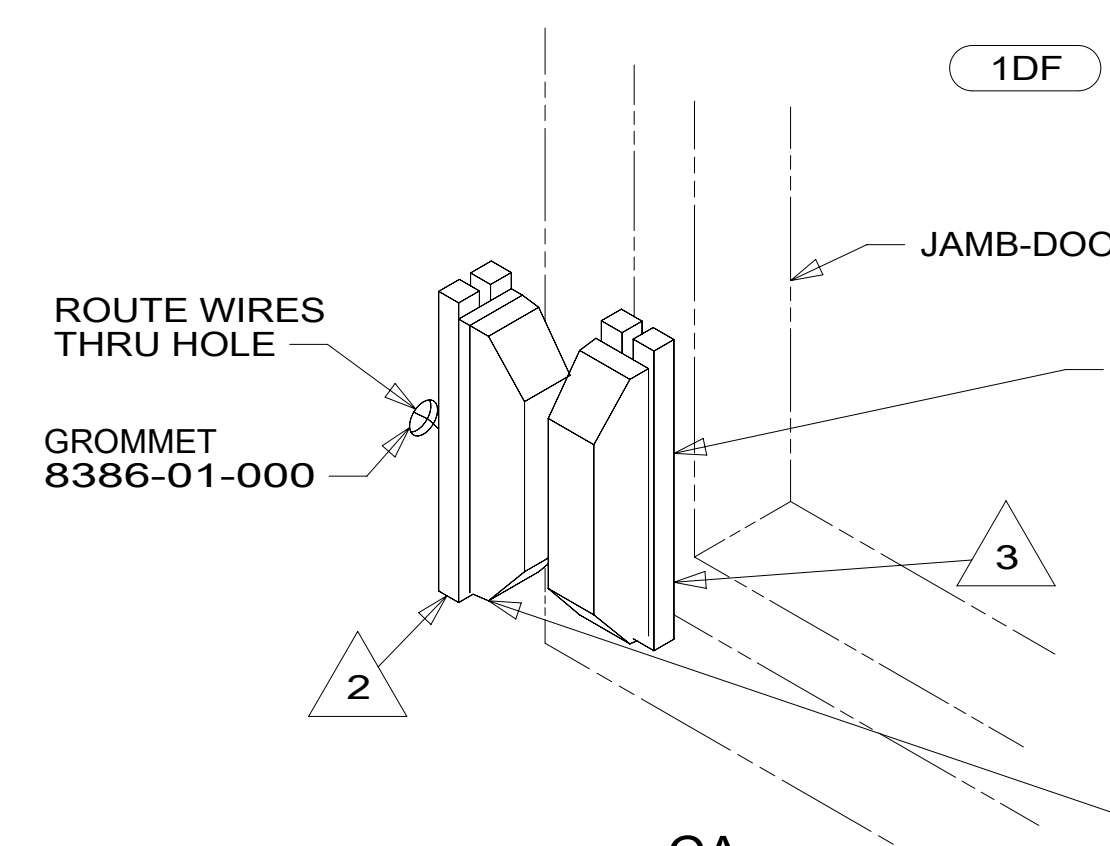

1DF	EXT TV ENTERTAINMENT CENTER
265	CODES/STANDARDS-CSA/CMVSS
1B1	CODES/STANDARDS USA
1B1	265
DESCRIPTION: <b>WIRING INSTL-BODY, 12V</b>	
SHEET: 3 OF 7	ITEM/PART NO: 000016444 / 31316201000
REV	

FOR ELECTRICAL TORQUE SPECIFICATIONS SEE DWG NO. 128783-01-000

X-X

FOR ELECTRICAL CALLOUTS SEE DWG NO. 121339-01-000

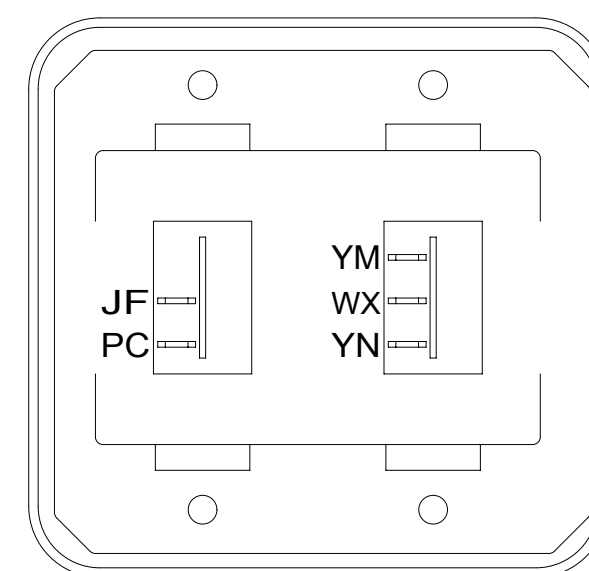

SWITCH-ROCKER  
135740-01-CHT  
135740-02-CHT  
SWITCH-BASE  
135741-02-CHT  
SWITCH-BEZEL  
135742-02-CHT  
SCREW  
G11-08-08U (4)

DETAIL DA

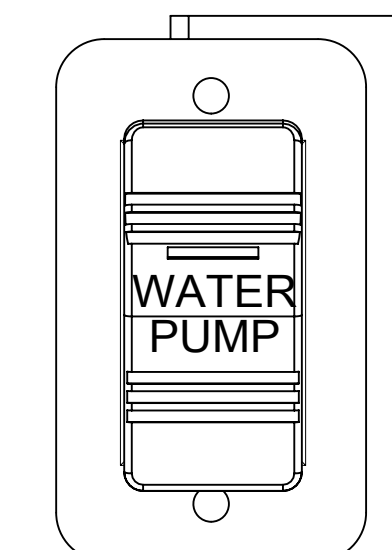

SWITCH-PUMP  
108357-21-000  
ACTUATOR  
108356-23-CHT  
PLATE  
98351-07-CHT  
SCREW  
G11-06-10U (2)

DETAIL DF

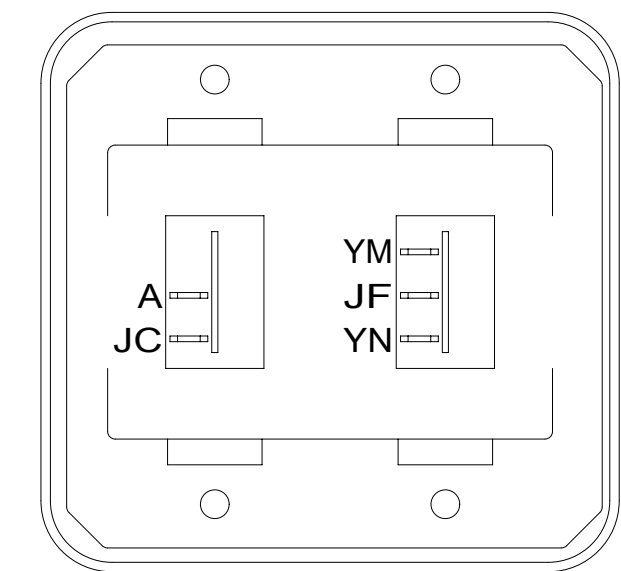

SWITCH-ROCKER  
135740-01-CHT  
135740-02-CHT  
SWITCH-BASE  
135741-02-CHT  
SWITCH-BEZEL  
135742-02-CHT  
SCREW  
G11-08-08U (4)

DETAIL DG

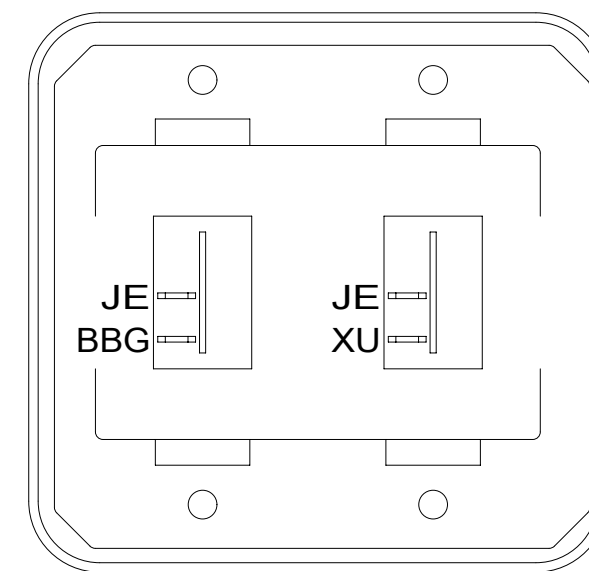

SWITCH-ROCKER  
135740-01-CHT (2)  
SWITCH-BASE  
135741-02-CHT  
SWITCH-BEZEL  
135742-02-CHT  
SCREW  
G11-08-08U (4)

DETAIL DB

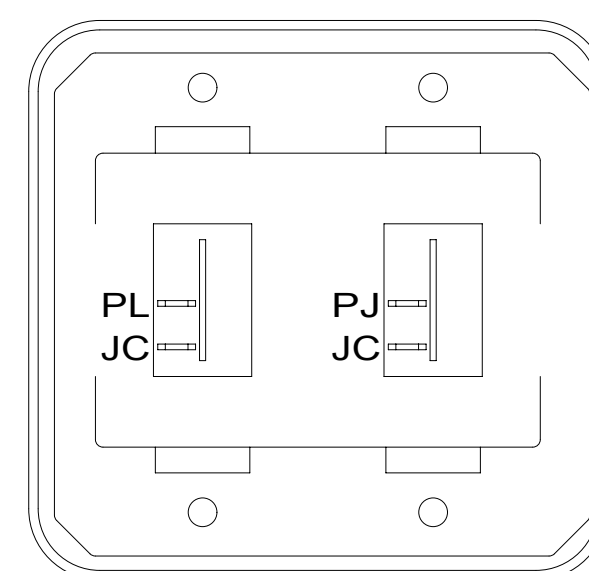

SWITCH-ROCKER  
135740-01-CHT (2)  
SWITCH-BASE  
135741-02-CHT  
SWITCH-BEZEL  
135742-02-CHT  
SCREW  
G11-08-08U (4)

DETAIL DC

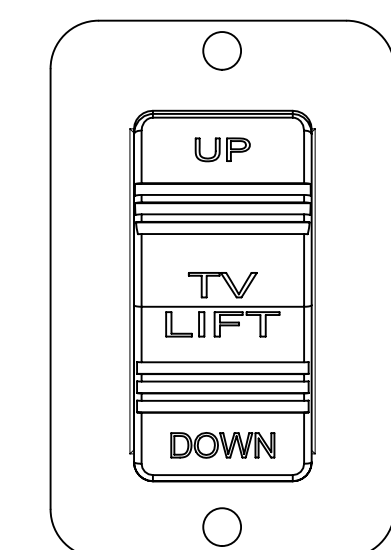

SWITCH-TV-LIFT  
108357-16-000  
ACTUATOR  
108356-26-CHT  
PLATE  
98351-07-CHT  
SCREW  
G11-06-10U (2)

DETAIL DD (2 PLACES)

PLATE-SWITCH  
158431-23-CHT  
SCREW  
G11-06-10U (6)

SWITCH-COMT LIGHTS  
108357-01-000  
ACTUATOR-SWITCH  
108356-14-CHT  
CIRCUITS WC,NW

SWITCH-COACH BATT  
108357-18-000  
ACTUATOR-SWITCH  
108356-19-CHT  
CIRCUITS KF,LJ,LG,  
LH,WC  
WIRE ASM-THERM  
186796-01-000

SWITCH-AWNING  
108357-06-000  
ACTUATOR-SWITCH  
108356-12-CHT  
CIRCUITS  
FFD,FFR,FFE,  
FFE,JJR,FFD

SWITCH-AWNING  
108357-14-000  
ACTUATOR-SWITCH  
108356-28-CHT  
CIRCUITS  
WC,WE,ZZK

SWITCH-AUTO LEVEL  
108357-18-000  
ACTUATOR-SWITCH  
108356-15-CHT  
CIRCUITS SSD,SSE,  
,SSC,SSE,SSF

SWITCH-STEP  
108357-19-000  
CIRCUITS ER,ES

SWITCH-CHASSIS BATTERY  
108357-18-000  
ACTUATOR-SWITCH  
108356-20-CHT  
CIRCUITS TTY,TTZ,MK,  
UUB,UUC  
WIRE ASM-THERM  
186796-01-000

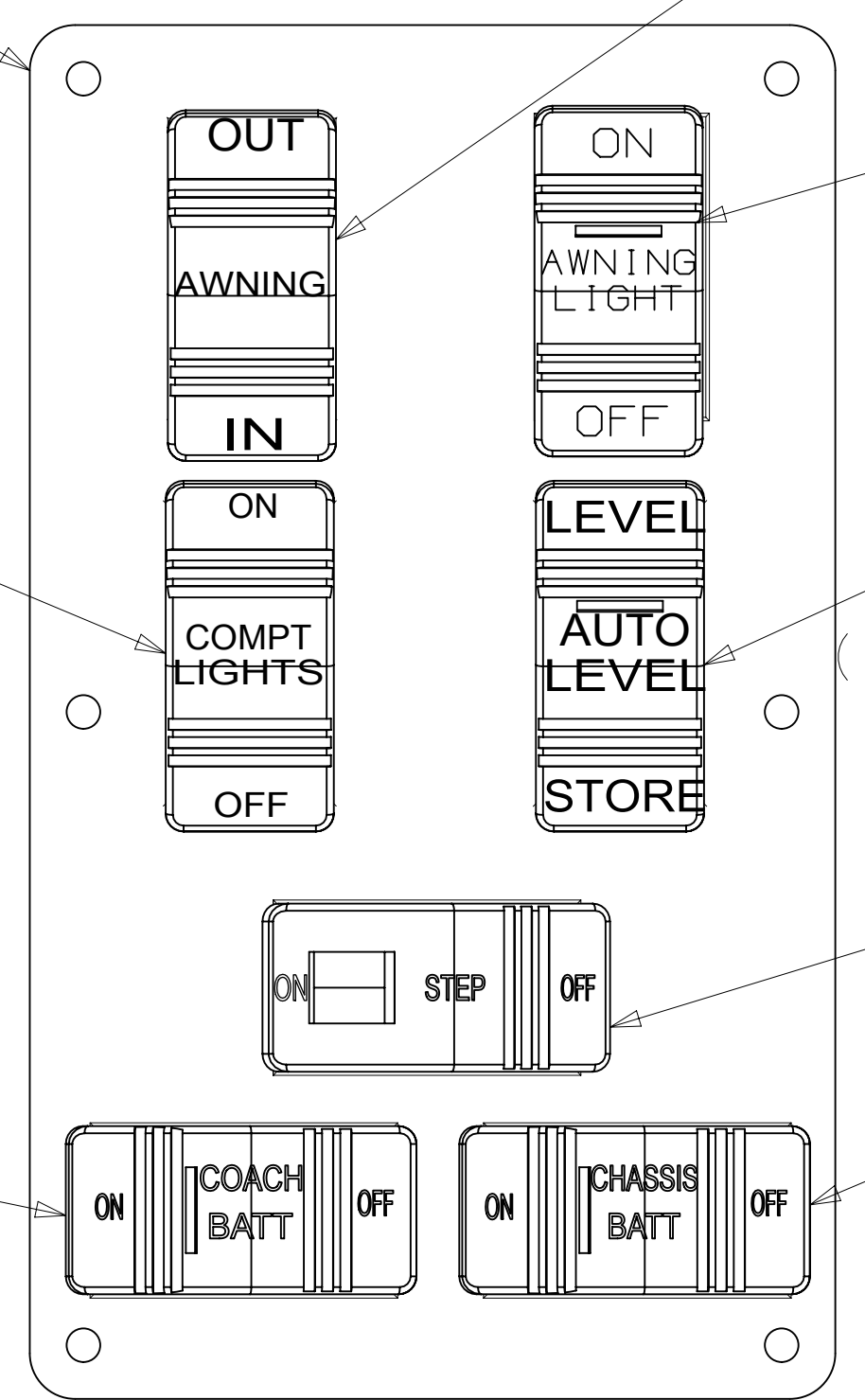

DETAIL DH 1

LABEL-SLIDEOUT,PASS,FRONT  
163992-04-CHT

SLIDEOUT-ELEC,FRONT  
171341-01-000  
SCREW  
76790-05-000 (2)

SWITCH  
108357-06-000  
ACTUATOR  
108356-25-CHT  
PPP,PPV,PPN,  
PPN,PPU,PPP.

CONNECT TO 12-PIN  
HOUSING WITH CIRCUITS  
SSN,NNP,NNR,NNN,  
HHE,HHF,WWW,WWP.

LABEL-WARNING,SLIDEOUT  
116549-01-000

SWITCH-CONTROL,LOFTBED,TOUCH  
189056-01-000  
WIRE ASM-LOFTBED SWITCH  
000122806 / 323456-01-000  
SCREW  
000G11-02-08U (2)

LABEL-SLIDEOUT,  
DRIVER,FRONT  
163992-01-CHT

LABEL-SLIDEOUT,PASS,REAR  
163992-03-CHT

SWITCH  
108357-18-000  
ACTUATOR  
108356-31-CHT  
(HHH,KE,HHG)

SWITCH  
108357-18-000  
ACTUATOR  
108356-31-CHT  
(DR,KE,DU)

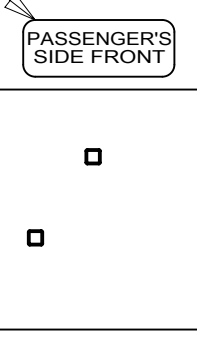

DETAIL DN

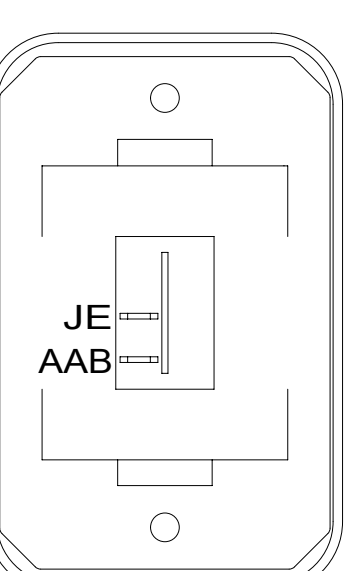
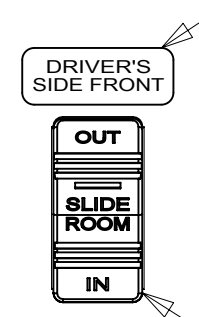

SWITCH-ROCKER  
135740-01-CHT  
SWITCH-BASE  
135741-01-CHT  
SWITCH-BEZEL  
135742-01-CHT  
SCREW  
G11-08-08U (2)

DETAIL DE

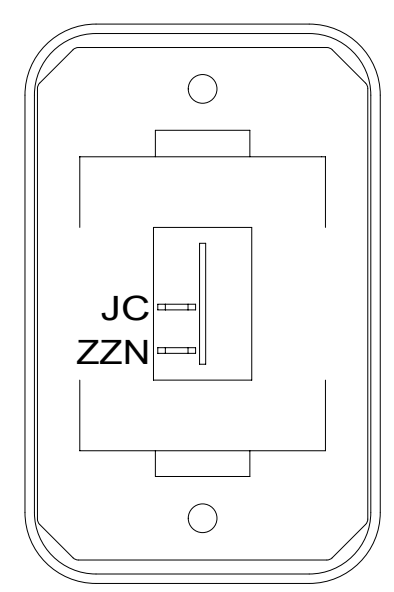

SWITCH-ROCKER  
135740-01-CHT  
SWITCH-BASE  
135741-01-CHT  
SWITCH-BEZEL  
135742-01-CHT  
SCREW  
G11-08-08U (2)

DETAIL DS

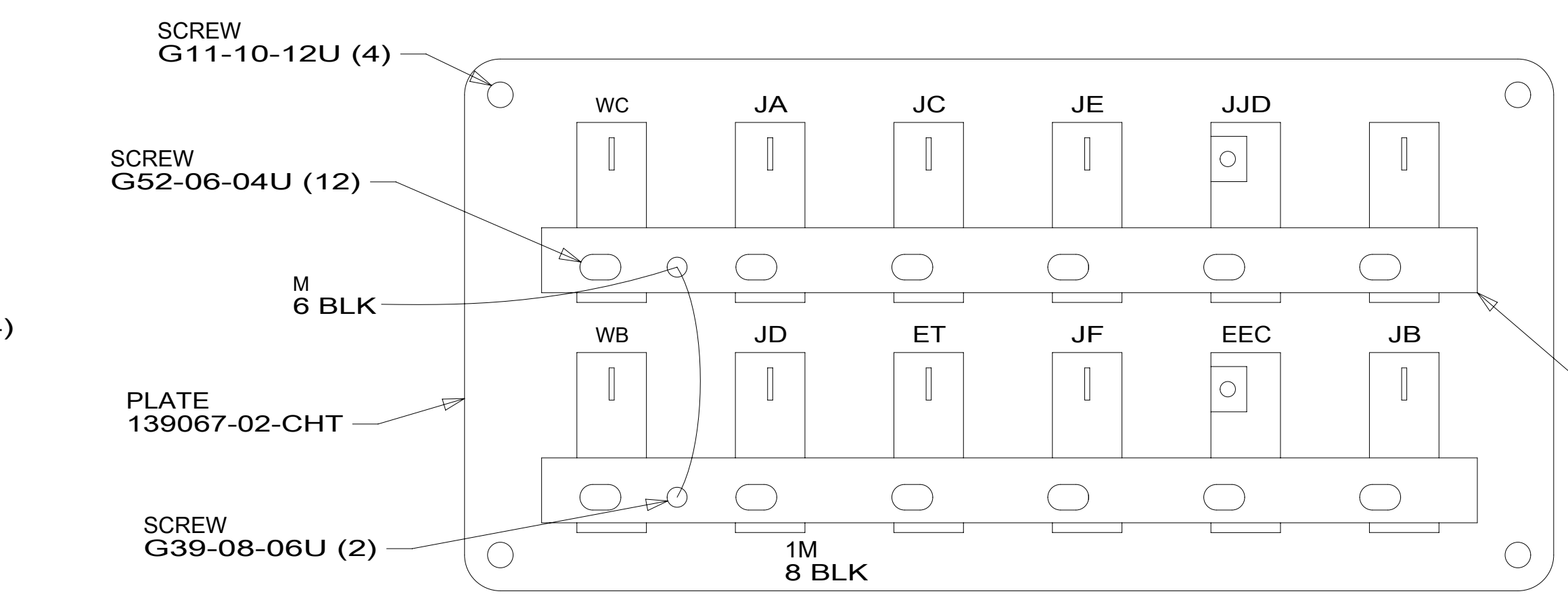

DETAIL DK (BACK VIEW)

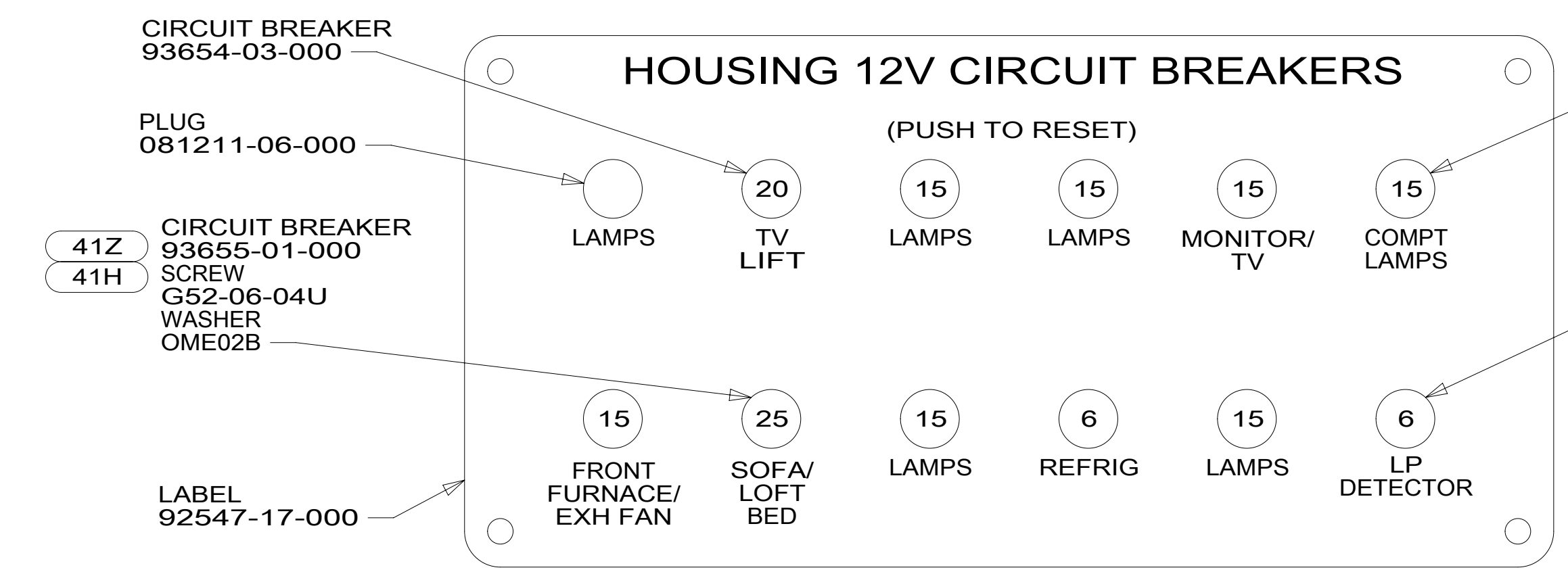

DETAIL DK (FRONT VIEW)

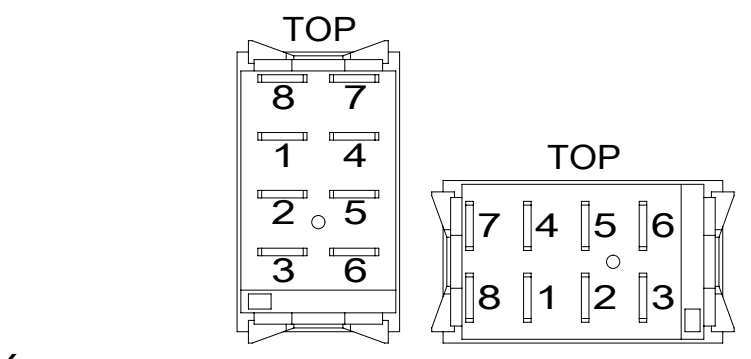

DETAIL DJ

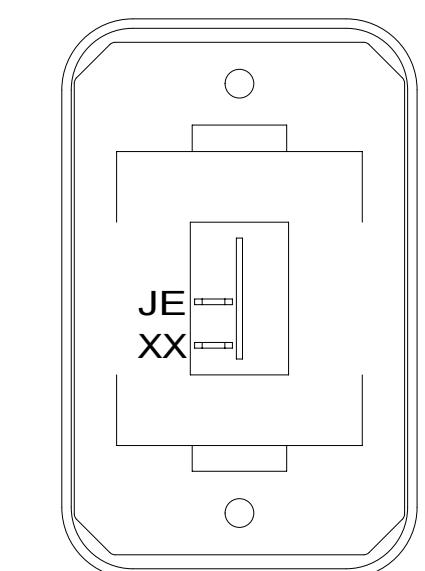

SWITCH-ROCKER  
135740-01-CHT  
SWITCH-BASE  
135741-01-CHT  
SWITCH-BEZEL  
135742-01-CHT  
SCREW  
G11-08-08U (2)

DETAIL DT

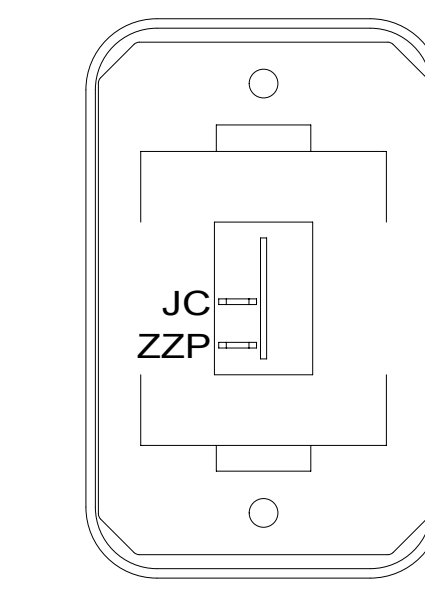

SWITCH-ROCKER  
135740-01-CHT  
SWITCH-BASE  
135741-01-CHT  
SWITCH-BEZEL  
135742-01-CHT  
SCREW  
G11-08-08U (2)

DETAIL DR

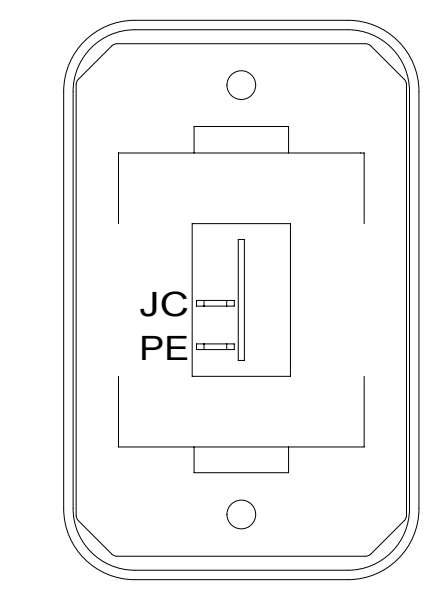

SWITCH-ROCKER  
135740-01-CHT  
SWITCH-BASE  
135741-01-CHT  
SWITCH-BEZEL  
135742-01-CHT  
SCREW  
G11-08-08U (2)

DETAIL DM

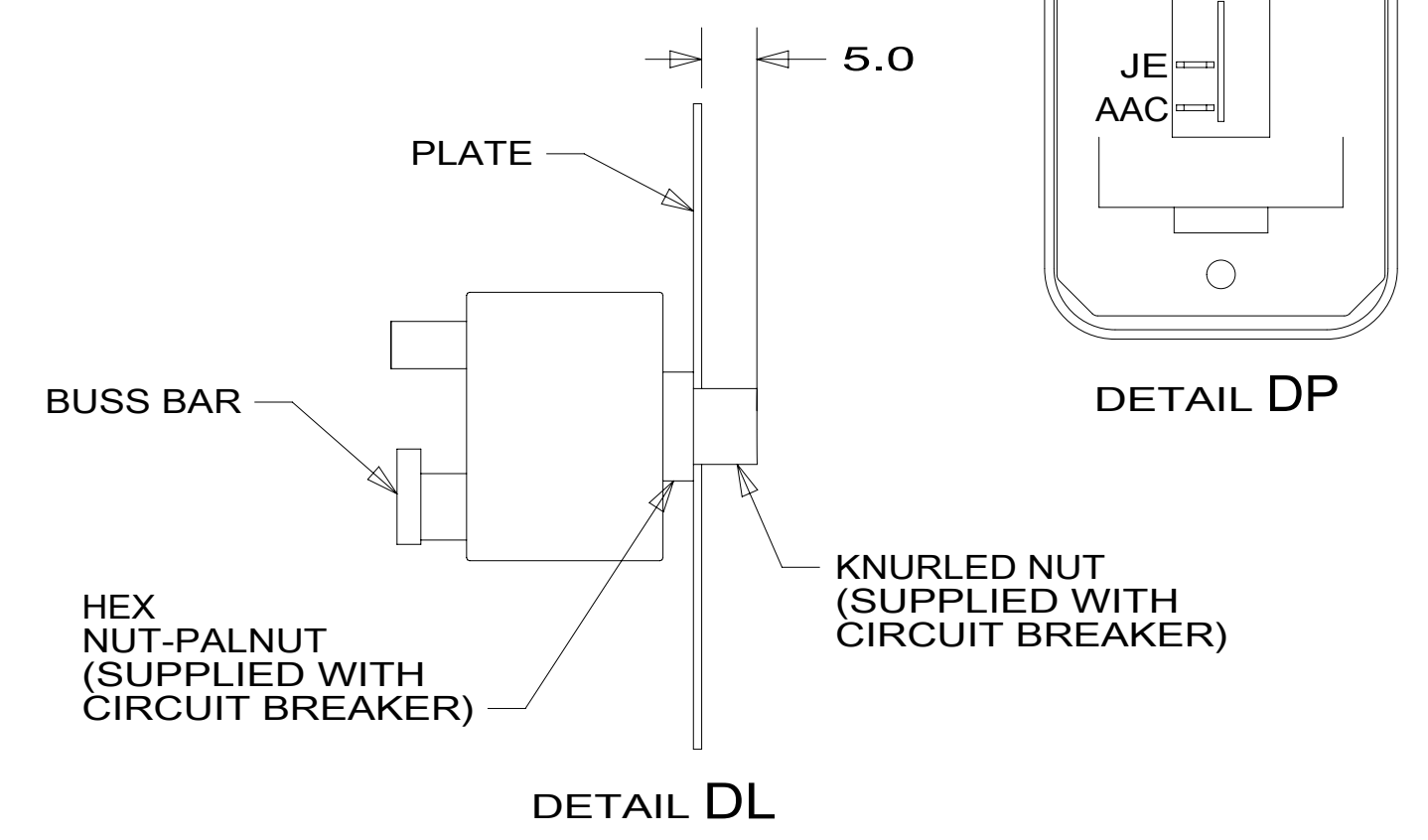

DETAIL DL

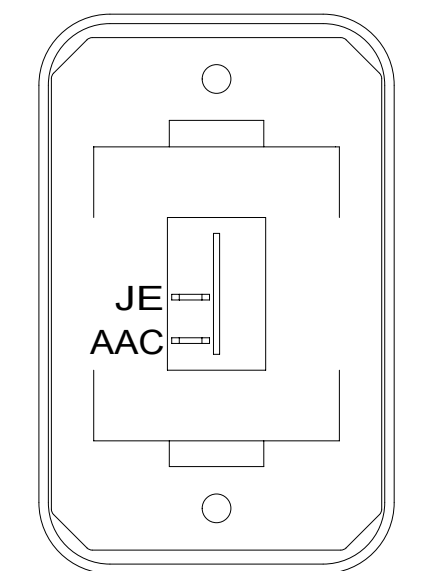

SWITCH-ROCKER  
135740-01-CHT  
SWITCH-BASE  
135741-01-CHT  
SWITCH-BEZEL  
135742-01-CHT  
SCREW  
G11-08-08U (2)

DETAIL DP

NOTES:  
1 FOR SWITCH ORIENTATION SEE DETAIL DJ.

FOR ELECTRICAL TORQUE SPECIFICATIONS SEE DWG NO. 128783-01-000

FOR ELECTRICAL CALLOUTS SEE DWG NO. 121339-01-000

- 45B LOFT BED
- 41Z RESTEASY DUAL CTL ULTRALE RH
- 41H REST EASY, ULTRALEATHER
- 265 CODES/STANDARDS-CSA/CMVSS
- 1B1 CODES/STANDARDS USA

DESCRIPTION: <b>WIRING INSTL-BODY, 12V</b>		
SHEET: 4 OF 7	ITEM/PART NO: 000016444 / 31316201000	REV

8

7

6

5

4

3

2

1

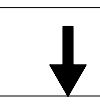

D

D

C

C

B

B

A

A

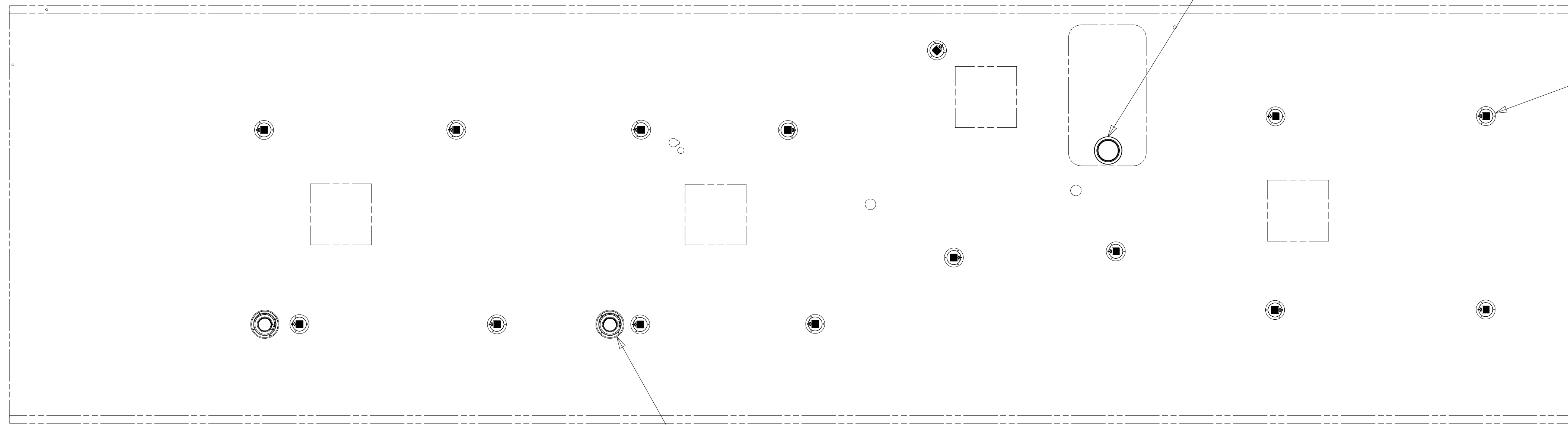

SPEAKER-ROUND,CEILING  
180783-01-CHT (2)  
SCREW  
G11-10-12U (8)

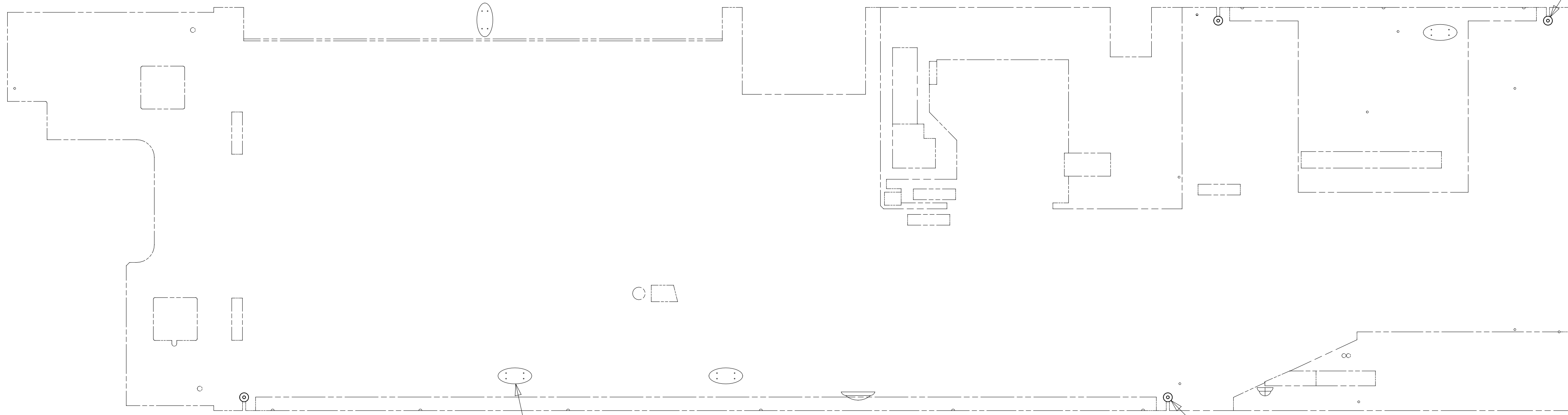

- 265 CODES/STANDARDS-CSA/CMVSS
- 1B1 CODES/STANDARDS USA

FOR ELECTRICAL  
TORQUE  
SPECIFICATIONS  
SEE DWG NO.  
128783-01-000

FOR  
ELECTRICAL  
CALLOUTS  
SEE DWG NO.  
121339-01-000

1B1 265	
DESCRIPTION: <b>WIRING INSTL-BODY, 12V</b>	
SHEET: 5 OF 7	ITEM/PART NO: 000016444 / 31316201000
REV	

8

7

6

5

4

3

2

1



8 7 6 5 4 3 2 1

THE SATELLITE DISH WIRE CONNECTIONS ARE TO BE PLACED ON THE CENTERLINE OF THE MOTORHOME FACING FORWARD

CONNECT CABLE ASM COAX (ORG-2) FROM ROOF ASM TO SEC INPUT ON SATELLITE DISH  
CONNECT 2-PIN HOUSING FROM ROOF ASM TO SATELLITE DISH HERE AND ADD CONVOLUTED TUBING  
CONNECT CABLE ASM COAX (ORG) FROM ROOF ASM TO MAIN INPUT ON SATELLITE DISH

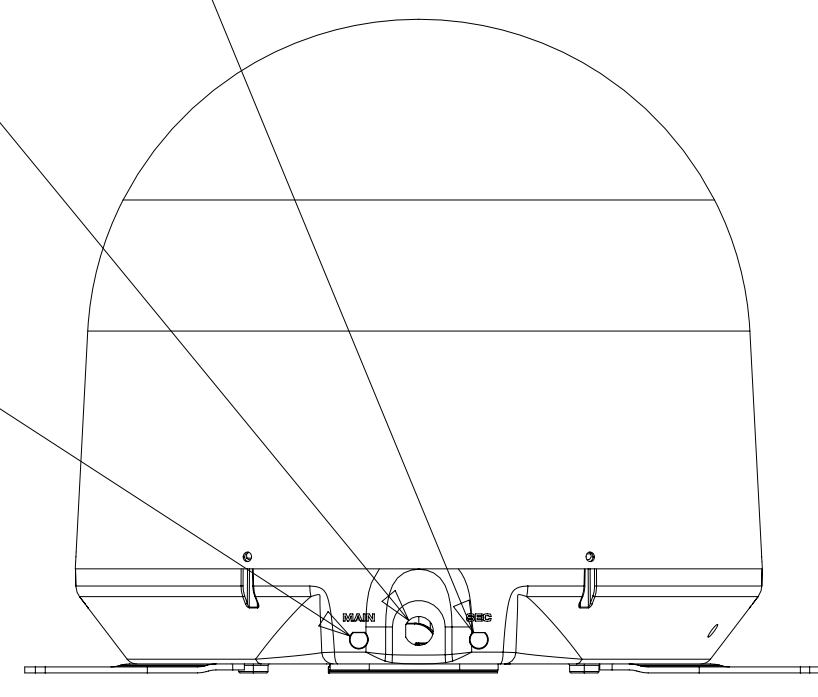

VIEW FC-FC

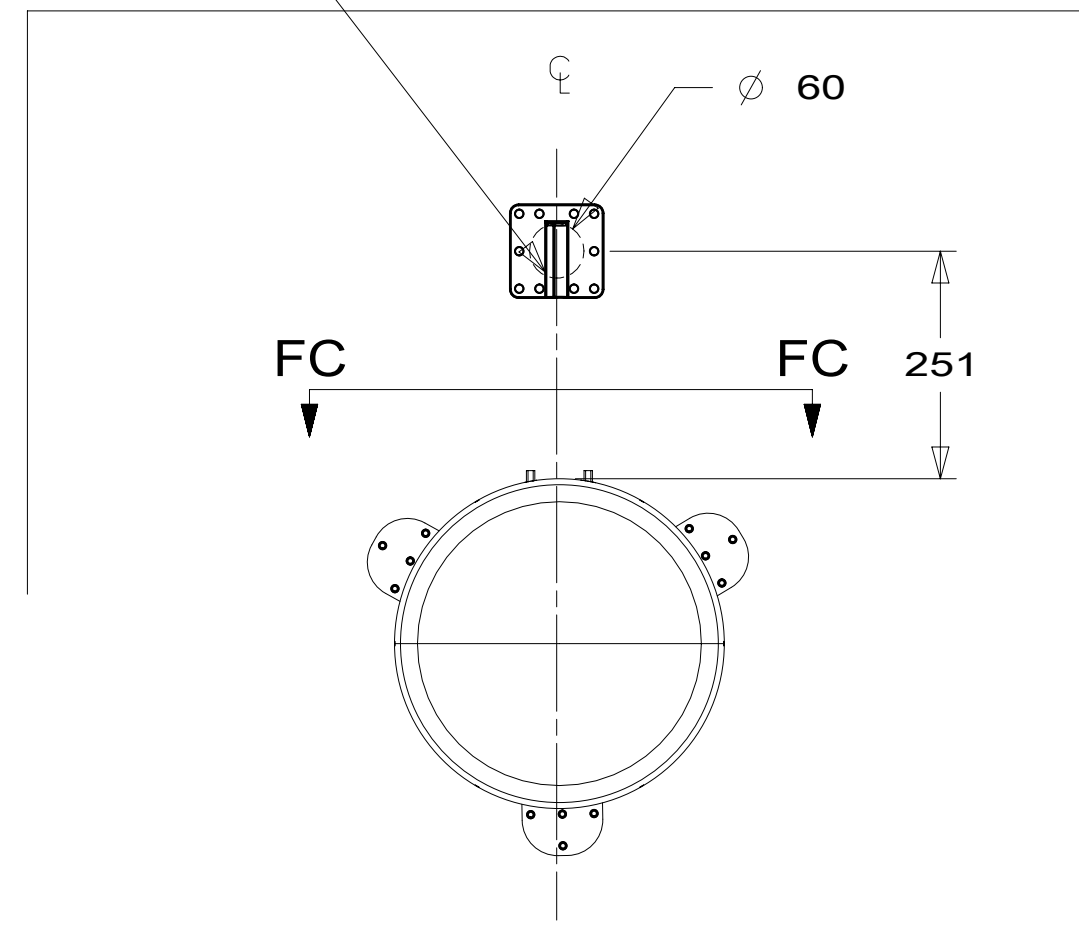

DETAIL FB 3

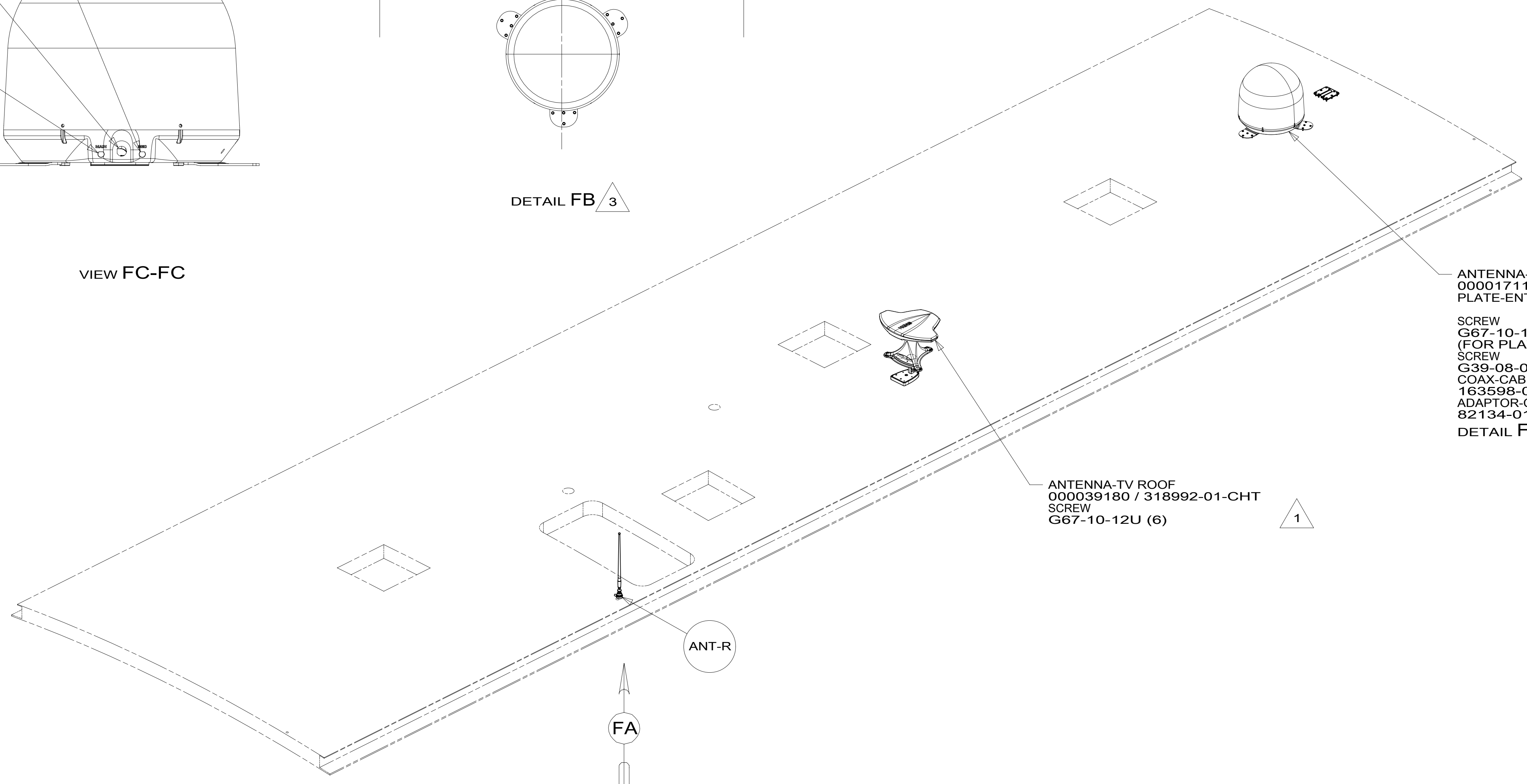

ANTENNA-SATELLITE, STATIONARY  
000017113 / 313336-01-CHT  
PLATE-ENTRY

- SCREW G67-10-12U (8) (FOR PLATE)
- SCREW G39-08-08U (12)
- COAX-CABLE 163598-04-000 (2)
- ADAPTOR-COAX 82134-01-000 (2)
- DETAIL FB

78K

ANTENNA-TV ROOF  
000039180 / 318992-01-CHT  
SCREW G67-10-12U (6)

1

ANT-R

FA

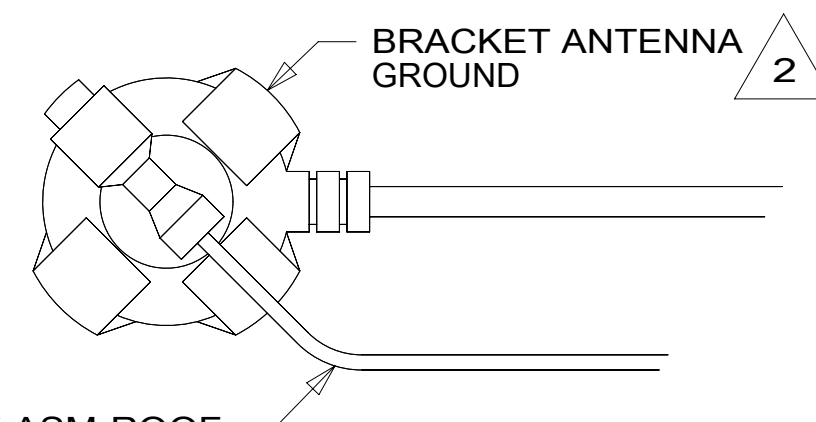

VIEW FA

BRACKET ANTENNA GROUND

JP FROM WIRE ASM-ROOF

- NOTES:
- 3 SEE MANUFACTURER'S INSTALLATION FOR ADDITIONAL INFORMATION.
  - 2 WRAP LEGS AROUND ANTENNA BASE.
  - 1 SEE ANTENNA INSTALLATION MANUAL FOR CORRECT INSTALLATION PROCEDURE.

- 78K SATELLITE TV SYSTEM AUTO
- 265 CODES/STANDARDS-CSA/CMVSS
- 1B1 CODES/STANDARDS USA

FOR ELECTRICAL TORQUE SPECIFICATIONS SEE DWG NO. 128783-01-000

FOR ELECTRICAL CALLOUTS SEE DWG NO. 121339-01-000

DESCRIPTION:		1B1 265	
<b>WIRING INSTL-BODY, 12V</b>			
SHEET:	ITEM/PART NO.:	REV:	
6 OF 7	000016444 / 31316201000		

8 7 6 5 4 3 2 1 20-Nov-2017

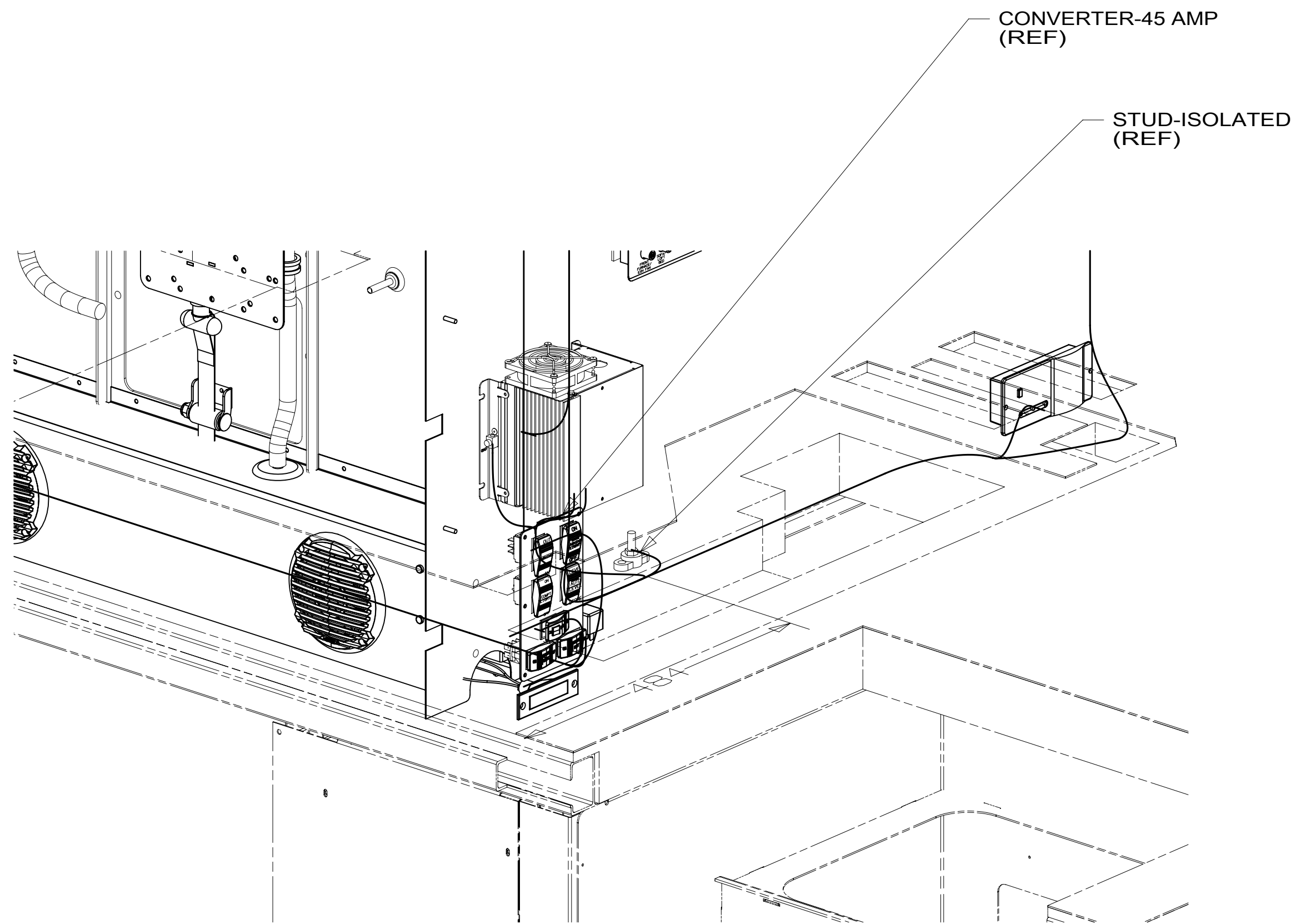

VIEW GB

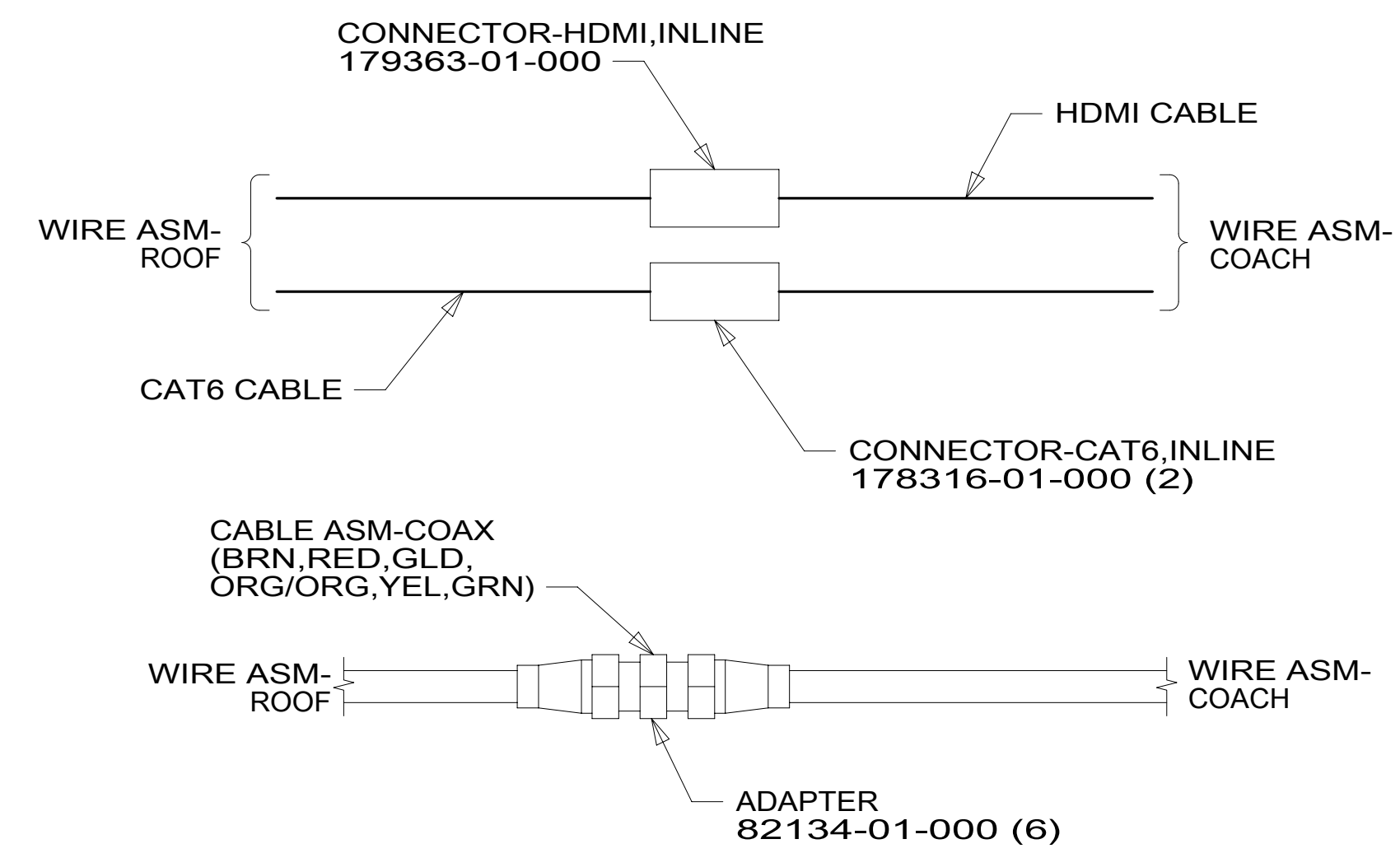

DETAIL GA

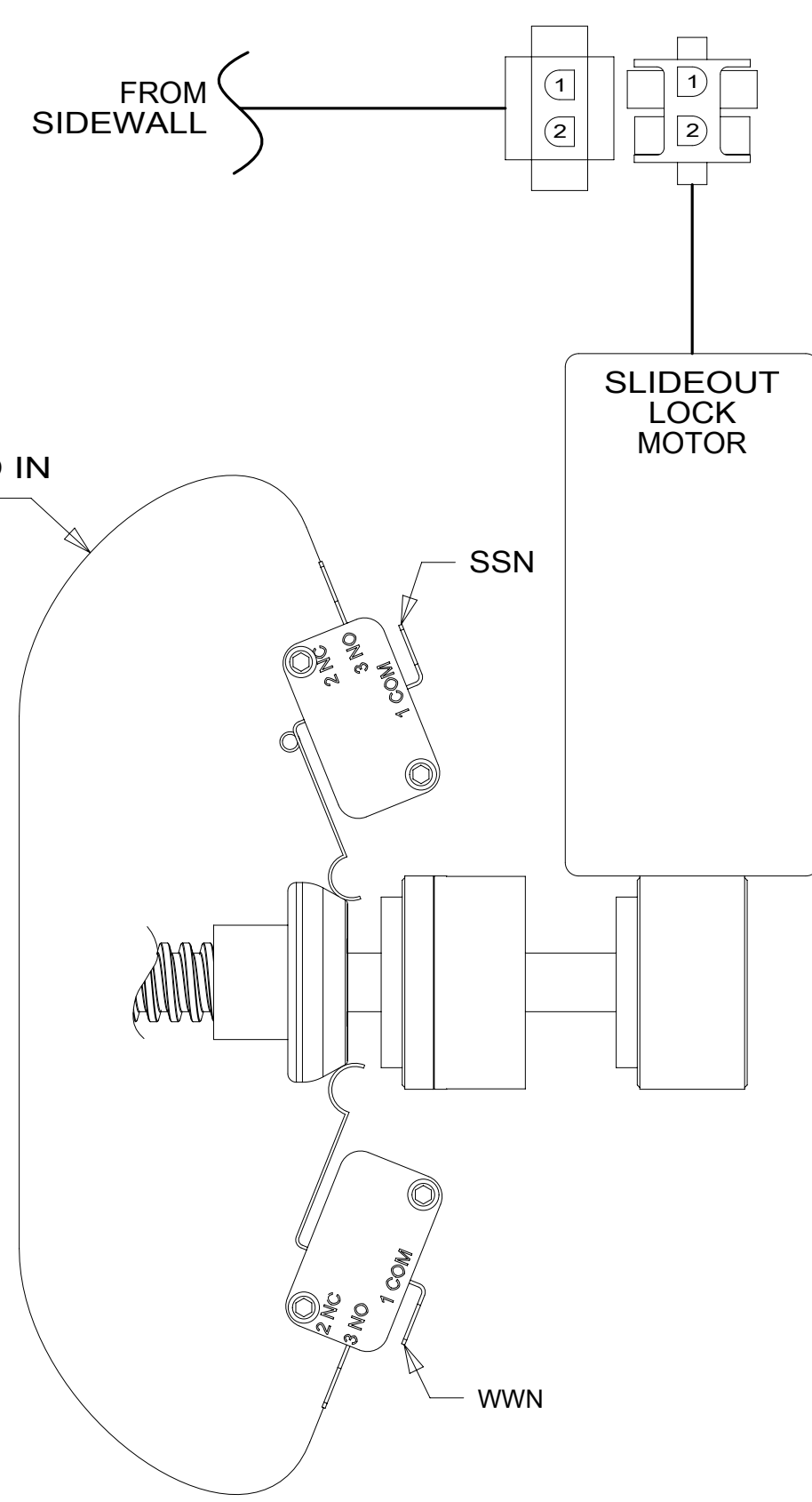

DETAIL GC (FRT RIGHT)

NOTES:  
 1 WRAP BOTH ENDS WITH TAPE 8363-01-000 TO SECURE CONNECTION.

FOR ELECTRICAL TORQUE SPECIFICATIONS SEE DWG NO. 128783-01-000

FOR ELECTRICAL CALLOUTS SEE DWG NO. 121339-01-000

- 265 CODES/STANDARDS-CSA/CMVSS
- 1B1 CODES/STANDARDS USA

DESCRIPTION:		1B1	265
<b>WIRING INSTL-BODY, 12V</b>			
SHEET:	ITEM/PART NO.:	REV	
7 OF 7	000016444 / 31316201000		