

8

7

6

5

4

3

2

1



D

D

C

C

B

B

A

A

		L34T	
RED	1B1	136135-07-070	
	265	136136-07-070	
GRN	1B1	136135-08-070	
	265	136136-08-070	
YEL	1B1	136131-05-069	1
	265	136134-05-069	1
GLD	1B1	136131-10-069	1
	265	136134-10-069	1
GLD-2	1B1	136131-20-069	1
	265	136134-20-069	1
BLU	1B1	136131-02-141	1
	265	136134-02-141	1
BRN	1B1	136131-03-115	
	265	136134-03-115	
PUR	1B1	136131-04-130	1
	265	136134-04-130	1
WHT	1B1	136135-09-035	53K
	265	136136-09-035	53K

		L34T	
ORG	1B1	136131-16-040	
	265	136134-16-040	
BLK	1B1	136131-06-069	1
	265	136134-06-069	1
GRY	1B1	136131-15-105	
	265	136134-15-105	
INVERTER CHARGER MAIN	1B1	136137-01-035	
	265	136138-01-035	
INVERTER CHARGER SUB MAIN	1B1	136137-01-035	
	265	136138-01-035	
CABLE ASM-MAIN,6 AWG		176841-01-028	
MAIN GROUND		136145-01-030	
ATS GROUND		136145-01-020	
INVERTER GROUND		136145-04-022	
GENERATOR CABLE ASM		136148-02-096	

14C

- 53K WTR HTR-10GAL/ELECTRIC/LPGAS
- 14C FIREPLACE-ELECTRIC
- 265 CODES/STANDARDS-CSA/CMVSS
- 1B1 CODES/STANDARDS USA

1B1 265



COPYRIGHT 2016 WINNEBAGO INDUSTRIES, INC.

DSNR:		ALL DIMENSIONS ARE IN MILLIMETERS	
DFFR:		MATERIAL:	
UNSPECIFIED TOLERANCES:			
WHOLE DIM (X)	: 3		
ONE-PLACE (X.X)	: 1.5		
TWO-PLACE (X.XX)	: 0.50		
ANGLE	: 1°		
REFER TO ES0018 FOR FASTENER TIGHTENING GUIDELINES		WEIGHT: (LBS)	FIRST USED:
			17 L34T
DESCRIPTION: LOAD CENTER/ATS ASM			
SHEET:	ITEM/PART NO.:	REV:	
1 OF 4	000015733 / 31295401000		

FOR ELECTRICAL TORQUE SPECIFICATIONS SEE DWG NO. 128783-01-000

FOR ELECTRICAL CALLOUTS SEE DWG 000228177 344479-01-000

NOTES:
1 SEE DETAIL BA FOR CONNECTOR INSTALLATION.

8

7

6

5

4

3

2

1

8

7

6

5

4

3

2

1

		L34T	
THROW IN WIRE #1	1B1	136131-05-025	1
	265	136134-05-025	1
THROW IN WIRE #2	1B1		
	265		
THROW IN WIRE #3	1B1	136131-02-064	
	265	136134-02-064	
THROW IN WIRE #4	1B1	136131-10-045	1
	265	136134-10-045	1
THROW IN WIRE #5	1B1	136131-20-045	1
	265	136134-20-045	1
THROW IN WIRE #6	1B1	136131-04-030	
	265	136134-04-030	
THROW IN WIRE #7	1B1	136131-02-032	1DF
	265	136134-02-032	1DF

		L34T	
SLIDEOUT WIRE #1		136151-04-032	2
SLIDEOUT WIRE #2		136151-05-028	2
SLIDEOUT WIRE #3		136151-02-028	2
SLIDEOUT WIRE #4		136151-06-028	2
SLIDEOUT WIRE #5		136151-10-028	2
SLIDEOUT WIRE #6		136151-20-028	2

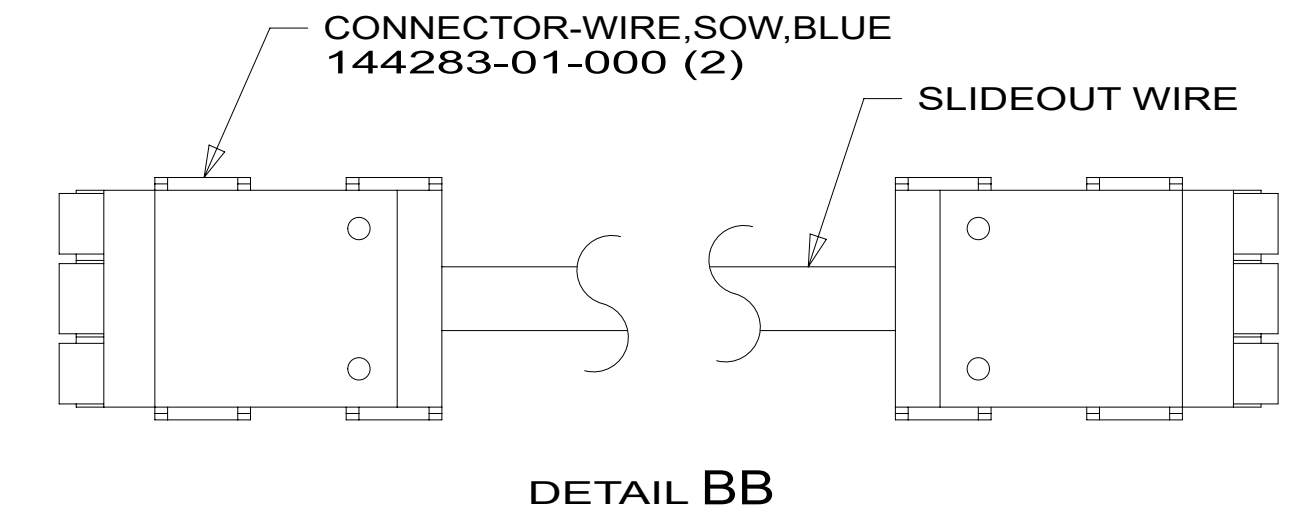
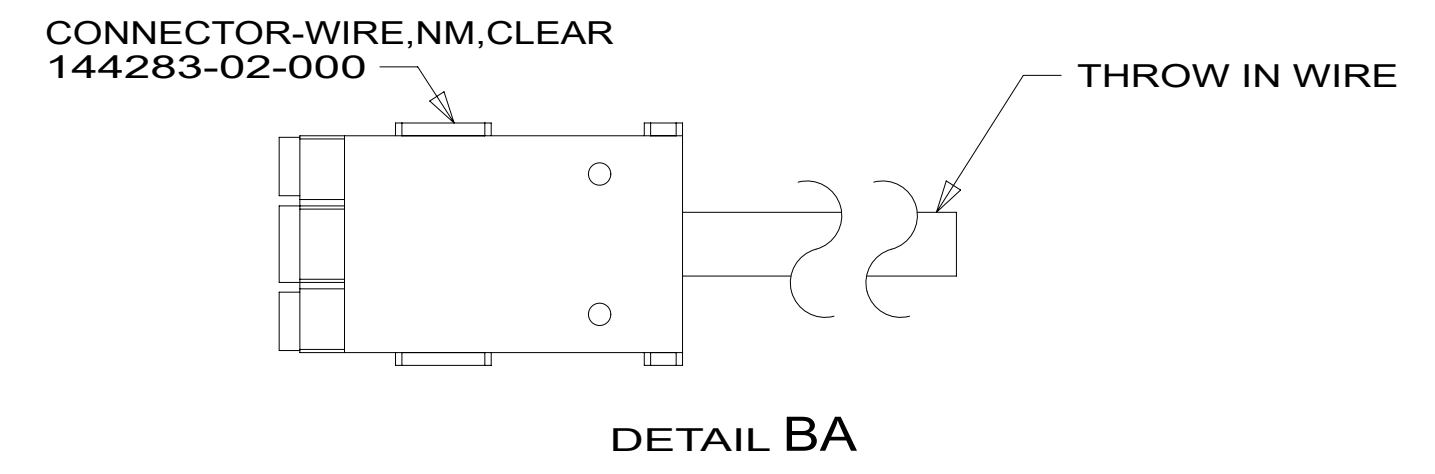

2 SEE DETAIL BB FOR CONNECTOR INSTALLATION.
1 SEE DETAIL BA FOR CONNECTOR INSTALLATION.

NOTES:

FOR ELECTRICAL TORQUE SPECIFICATIONS SEE DWG NO. 128783-01-000

FOR ELECTRICAL CALLOUTS SEE DWG 000228177 344479-01-000

- 1DF EXT TV ENTERTAINMENT CENTER
- 265 CODES/STANDARDS-CSA/CMVSS
- 1B1 CODES/STANDARDS USA

DESCRIPTION:	LOAD CENTER/ATS ASM	
SHEET:	ITEM/PART NO.:	REV
2 OF 4	000015733 / 31295401000	

8

7

6

5

4

3

2

1

05-Dec-2022

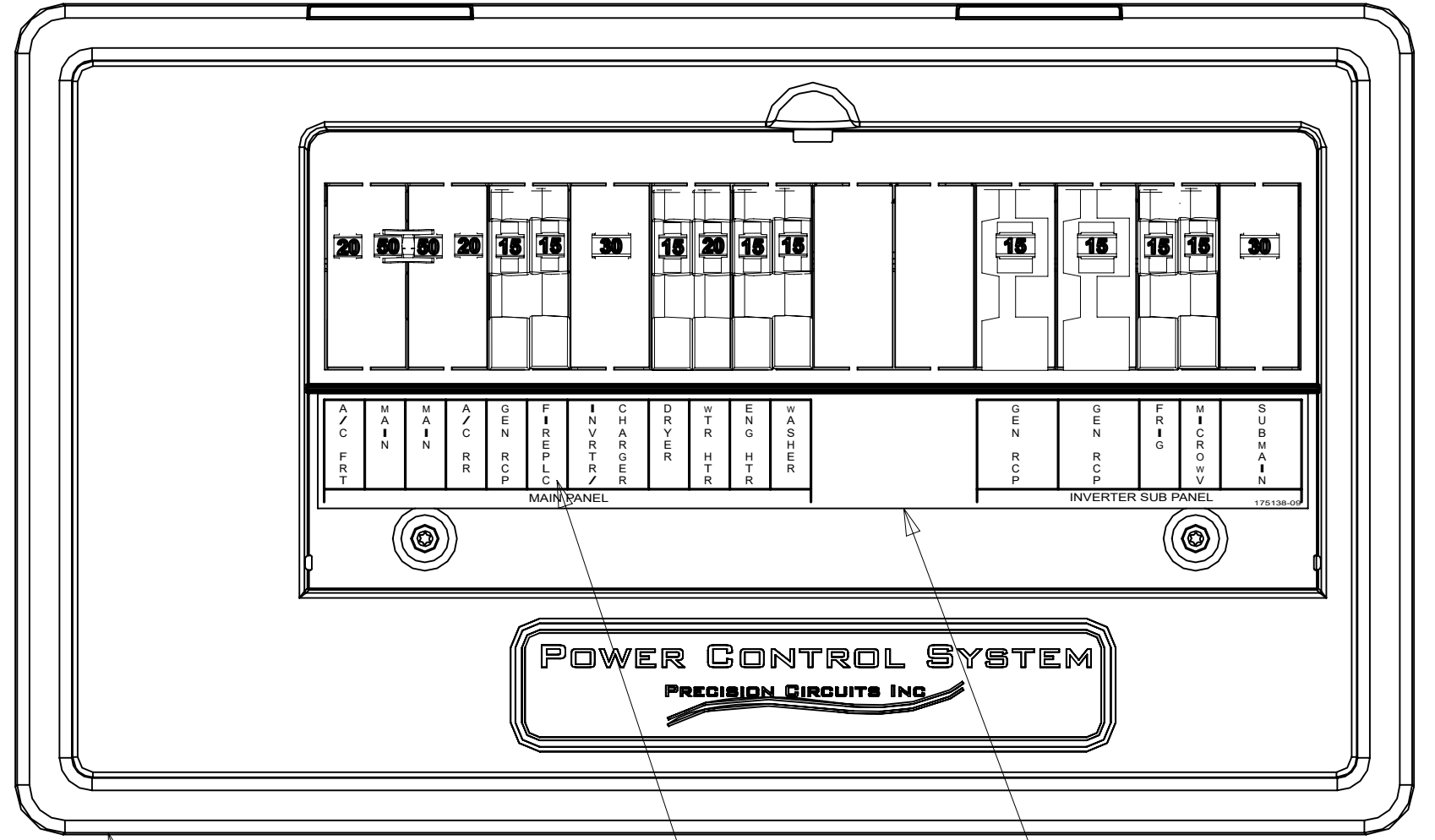
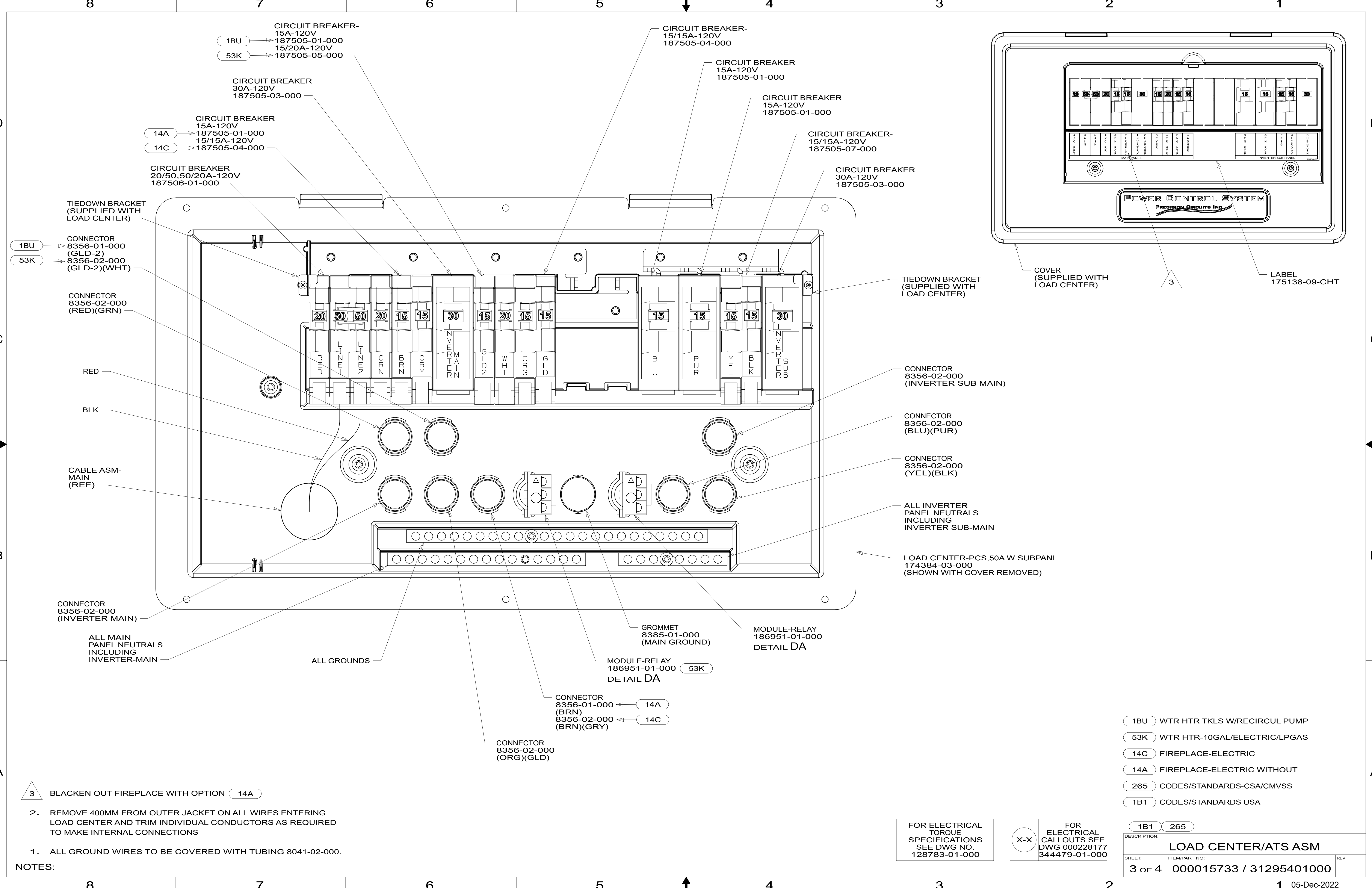

TIEDOWN BRACKET (SUPPLIED WITH LOAD CENTER)

CONNECTOR 8356-01-000 (GLD-2)
CONNECTOR 8356-02-000 (GLD-2)(WHT)

CONNECTOR 8356-02-000 (RED)(GRN)

RED

BLK

CABLE ASM-MAIN (REF)

CONNECTOR 8356-02-000 (INVERTER MAIN)

ALL MAIN PANEL NEUTRALS INCLUDING INVERTER-MAIN

3 BLACKEN OUT FIREPLACE WITH OPTION 14A

2. REMOVE 400MM FROM OUTER JACKET ON ALL WIRES ENTERING LOAD CENTER AND TRIM INDIVIDUAL CONDUCTORS AS REQUIRED TO MAKE INTERNAL CONNECTIONS

1. ALL GROUND WIRES TO BE COVERED WITH TUBING 8041-02-000.

NOTES:

FOR ELECTRICAL TORQUE SPECIFICATIONS SEE DWG NO. 128783-01-000

FOR ELECTRICAL CALLOUTS SEE DWG 000228177 344479-01-000

- 1BU WTR HTR TKLS W/RECIRCUL PUMP
- 53K WTR HTR-10GAL/ELECTRIC/LPGAS
- 14C FIREPLACE-ELECTRIC
- 14A FIREPLACE-ELECTRIC WITHOUT
- 265 CODES/STANDARDS-CSA/CMVSS
- 1B1 CODES/STANDARDS USA

DESCRIPTION:	1B1 265	
LOAD CENTER/ATS ASM		
SHEET:	ITEM/PART NO:	REV
3 OF 4	000015733 / 31295401000	

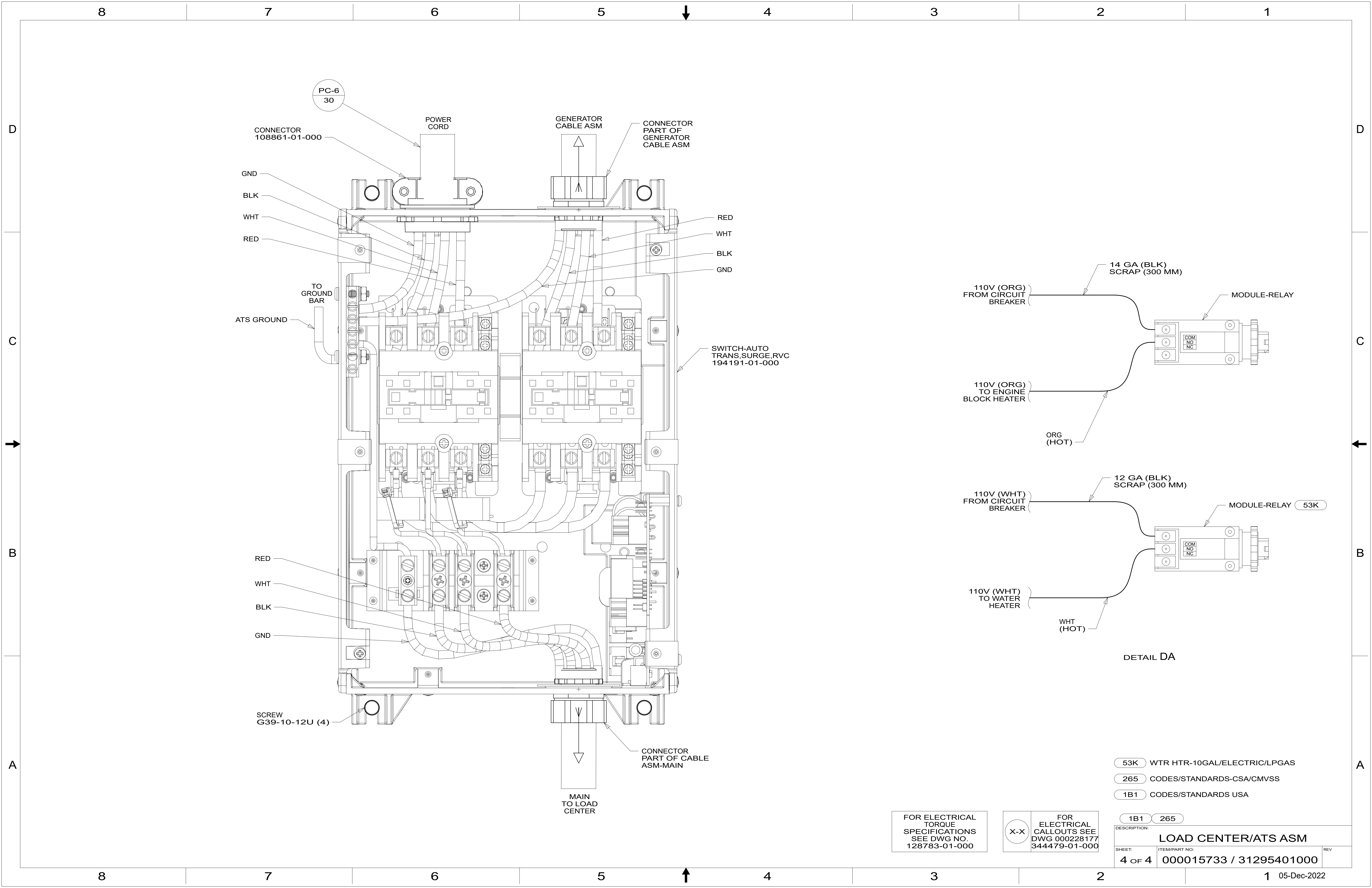

PC-6
30

CONNECTOR
108861-01-000

POWER
CORD

GENERATOR
CABLE ASM

CONNECTOR
PART OF
GENERATOR
CABLE ASM

GND

BLK

WHT

RED

RED

WHT

BLK

GND

TO
GROUND
BAR

ATS GROUND

SWITCH-AUTO
TRANS, SURGE, RVC
194191-01-000

RED

WHT

BLK

GND

SCREW
G39-10-12U (4)

CONNECTOR
PART OF CABLE
ASM-MAIN

MAIN
TO LOAD
CENTER

14 GA (BLK)
SCRAP (300 MM)

110V (ORG)
FROM CIRCUIT
BREAKER

MODULE-RELAY

110V (ORG)
TO ENGINE
BLOCK HEATER

ORG
(HOT)

110V (WHT)
FROM CIRCUIT
BREAKER

12 GA (BLK)
SCRAP (300 MM)

MODULE-RELAY 53K

110V (WHT)
TO WATER
HEATER

WHT
(HOT)

DETAIL DA

53K WTR HTR-10GAL/ELECTRIC/LPGAS

265 CODES/STANDARDS-CSA/CMVSS

1B1 CODES/STANDARDS USA

1B1 265

FOR ELECTRICAL
TORQUE
SPECIFICATIONS
SEE DWG NO.
128783-01-000

FOR
ELECTRICAL
CALLOUTS SEE
DWG 000228177
344479-01-000

DESCRIPTION: LOAD CENTER/ATS ASM		
SHEET: 4 OF 4	ITEM/PART NO.: 000015733 / 31295401000	REV