



8 7 6 5 4 3 2 1

D

D

C

C

B

B

A

A

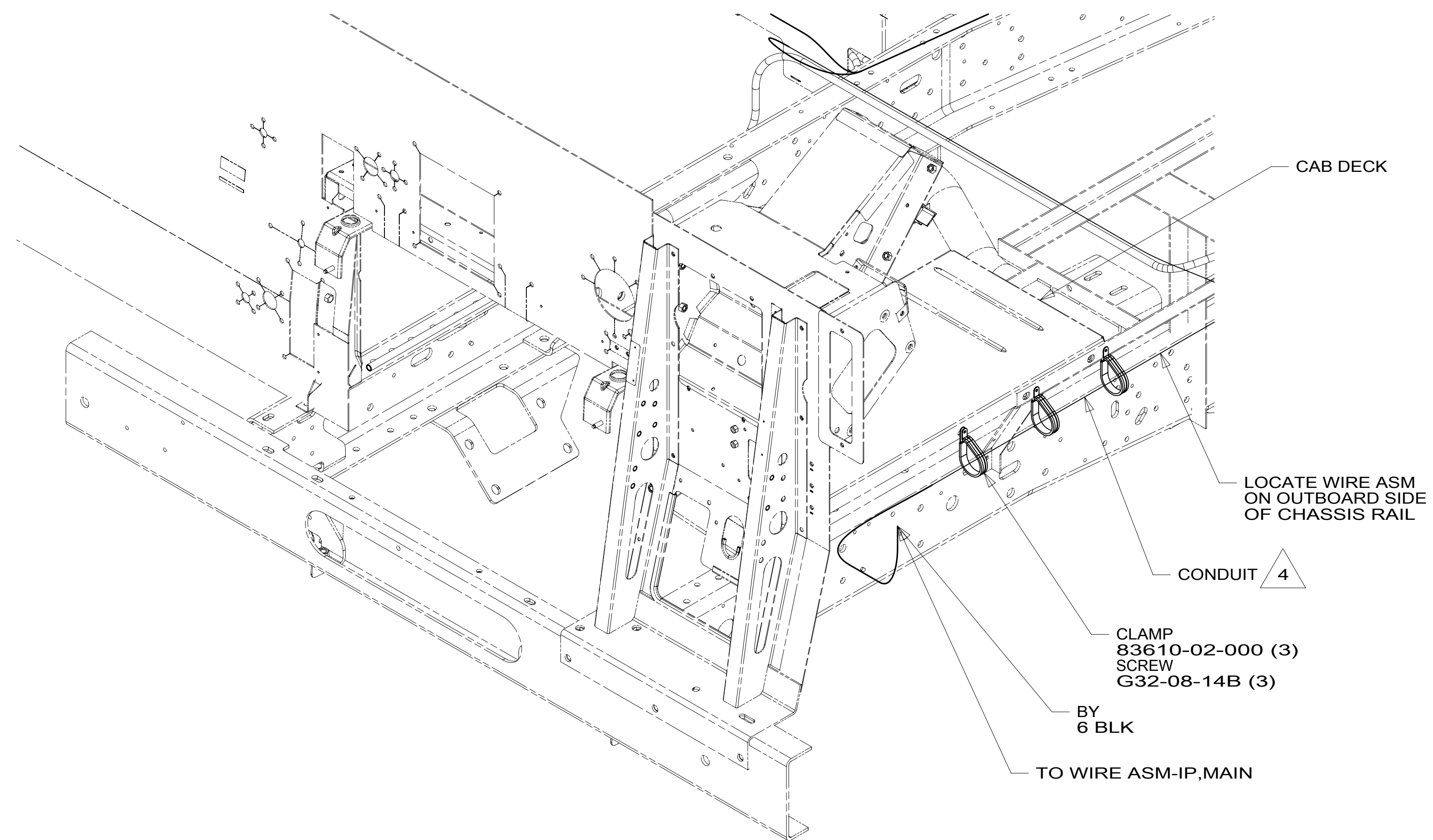

VIEW BA

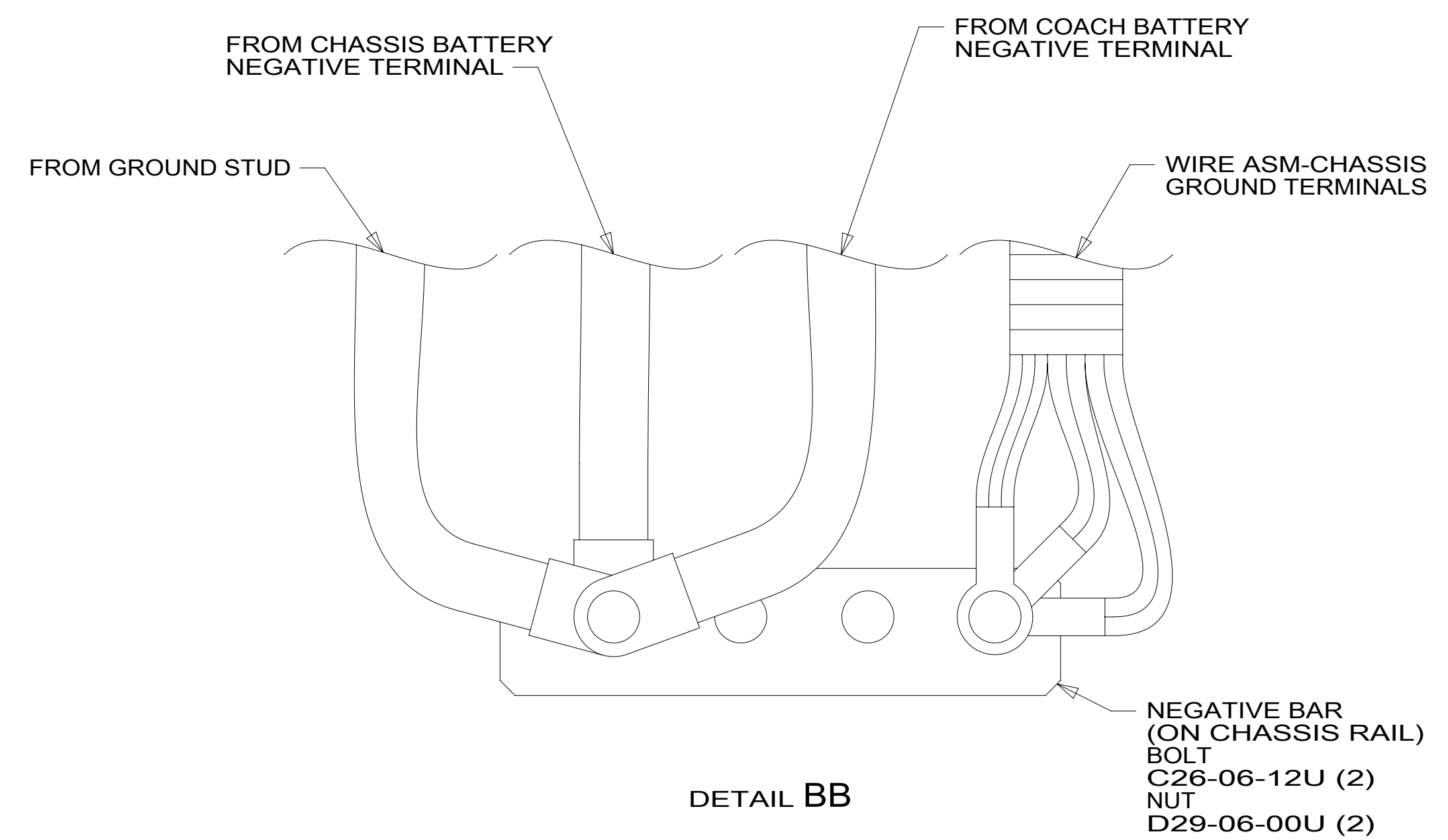

DETAIL BB

4 COVER WITH CONDUIT 41953-10-000 AND 41953-11-000 AS REQUIRED.

3. CONNECT CABLES TO COACH SIDE OF BATTERY DISCONNECT WHEN BATTERY DISCONNECT IS USED.

2. ALL GROUND WIRE TO BE COVERED WITH TUBING 8041-02-000.

1. CUT OFF EXCESS END OF WIRE TIE.

NOTES:

265 CODES/STANDARDS-CSA/CMVSS

1B1 CODES/STANDARDS USA

1B1 265

FOR ELECTRICAL TORQUE SPECIFICATIONS SEE DWG NO. 128783-01-000

FOR ELECTRICAL CALLOUTS SEE DWG NO. 121339-01-000

DESCRIPTION: WIRING INSTL-CHASSIS

SHEET: 2 OF 2 ITEM/PART NO: 000015242 / 31285101000 REV B

8 7 6 5 4 3 2 1 13-Dec-2016