

8 7 6 5 4 3 2 1

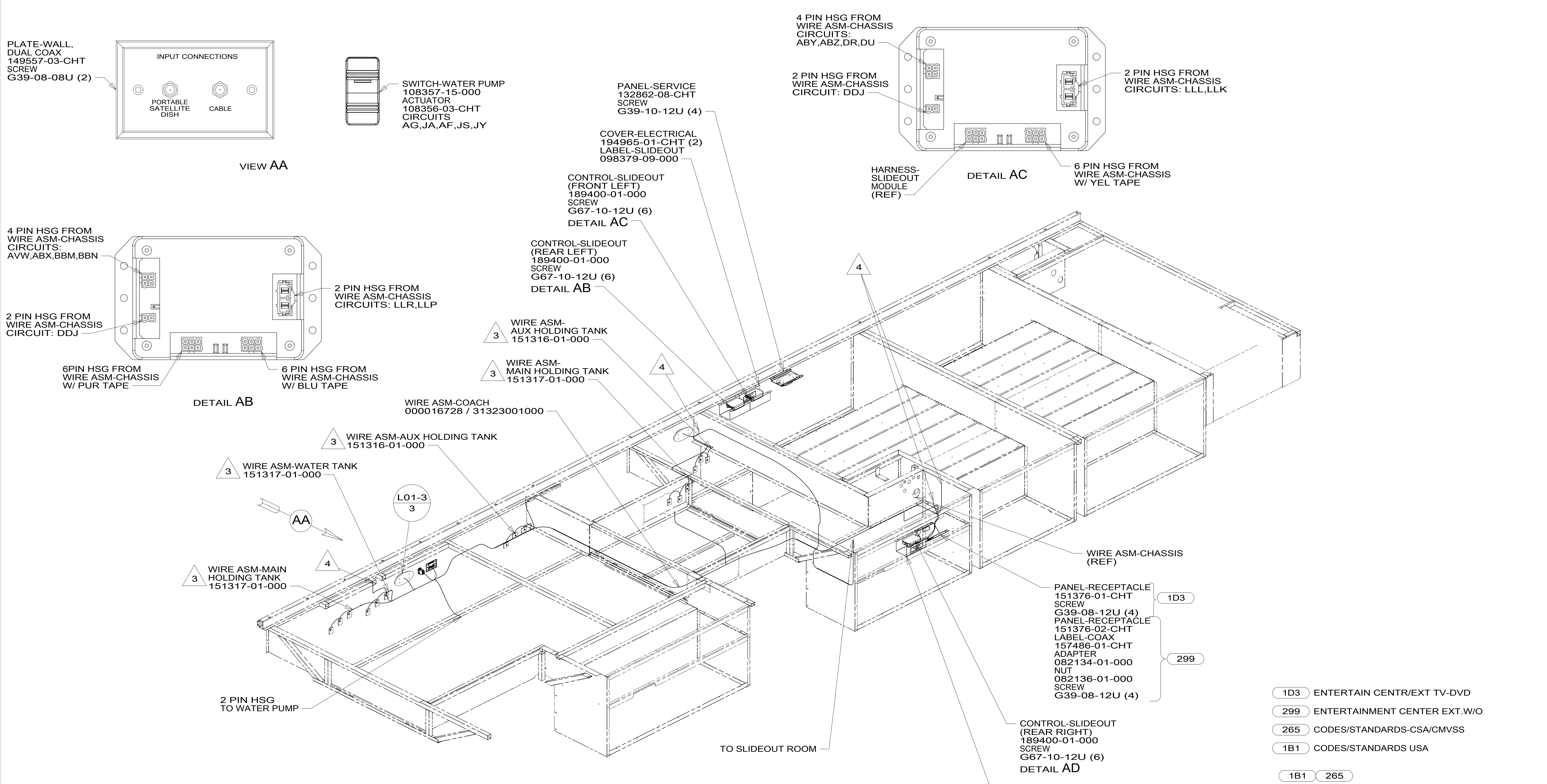

- NOTES:**
- 1. AT MINIMUM ALL WIRES TO BE SUPPORTED AND SECURED PER CODE REQUIREMENTS. USE CLAMP 10495 OR 10497 OR WIRE TIE 8343 OR 108046 AND SCREW G67-XX-XXX OR G56-XX-XXX AS APPROPRIATE FOR INSTALLATION.
  - 2. ROUTE TANK SENSOR WIRES SO THEY DO NOT PASS OVER SENSORS. USE WIRE TIE MOUNT 155366-01-000 AND WIRE TIE 8343-01-000 AS NEEDED. TANK SURFACE MUST BE CLEANED USING ISOPROPYL ALCOHOL AND PRIMED WITH PRIMER 94.
- 4 WIRE PASSES THROUGH FLOOR IN THIS AREA.  
3 PLACE CROSS LOCATOR ON SENSORS OVER DIMPLES ON TANK.

- 1D3 ENTERTAIN CENTR/EXT TV-DVD
- 299 ENTERTAINMENT CENTER EXT.W/O
- 265 CODES/STANDARDS-CSA/CMVSS
- 1B1 CODES/STANDARDS USA



DSNR:		ALL DIMENSIONS ARE IN MILLIMETERS	
DFFR:			
UNSPECIFIED TOLERANCES:		MATERIAL:	
WHOLE DIM (X)	: 3		
ONE-PLACE (X.X)	: 1.5		
TWO-PLACE (X.XX)	: 0.50		
ANGLE	: 1°		
REFER TO ES0018 FOR FASTENER TIGHTENING GUIDELINES		WEIGHT: (LBS)	FIRST USED:
			<b>17 E35B</b>
<b>DESCRIPTION:</b>			
<b>WIRING INSTL-BODY, 12V</b>			
SHEET:	ITEM/PART NO:	REV	
1 OF 9	000015237 / 31285001000		

FOR ELECTRICAL TORQUE SPECIFICATIONS SEE DWG NO. 128783-01-000

FOR ELECTRICAL CALLOUTS SEE DWG NO. 121339-01-000

8 7 6 5 4 3 2 1

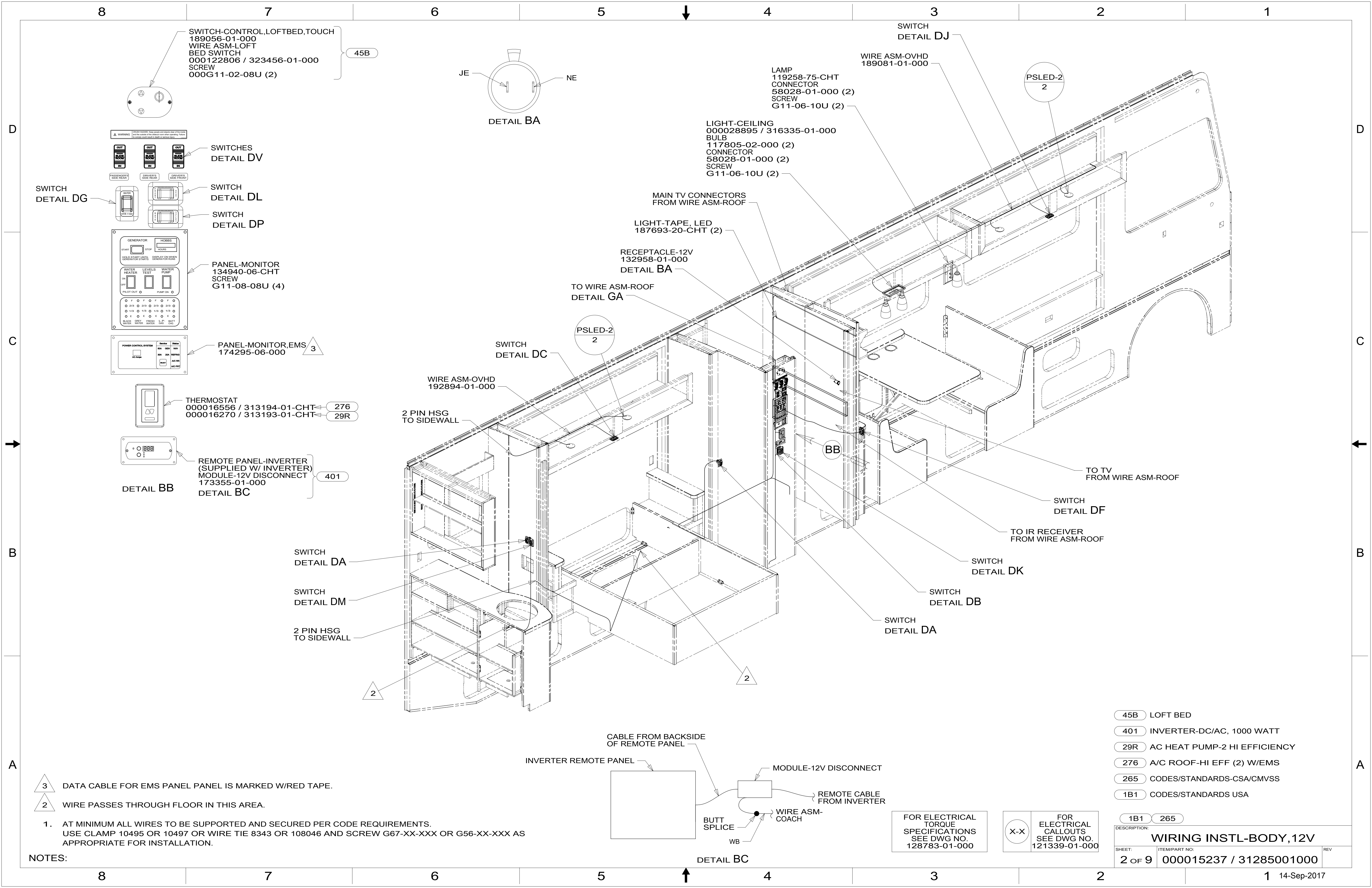

SWITCH-CONTROL,LOFTBED,TOUCH  
189056-01-000  
WIRE ASM-LOFT  
BED SWITCH  
000122806 / 323456-01-000  
SCREW  
000G11-02-08U (2)

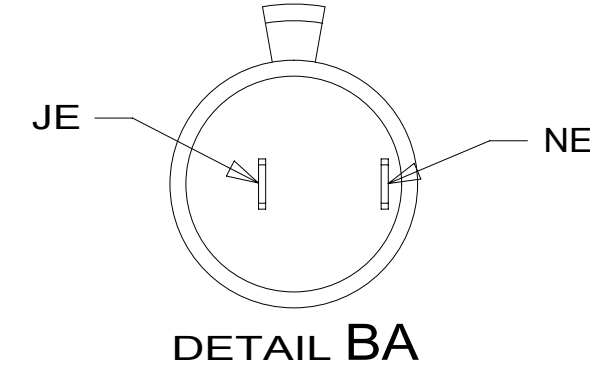

LAMP  
119258-75-CHT  
CONNECTOR  
58028-01-000 (2)  
SCREW  
G11-06-10U (2)

SWITCH  
DETAIL DJ

PSLED-2  
2

LIGHT-CEILING  
000028895 / 316335-01-000  
BULB  
117805-02-000 (2)  
CONNECTOR  
58028-01-000 (2)  
SCREW  
G11-06-10U (2)

RECEPTACLE-12V  
132958-01-000  
DETAIL BA

PSLED-2  
2

SWITCHES  
DETAIL DV

SWITCH  
DETAIL DG

SWITCH  
DETAIL DL

SWITCH  
DETAIL DP

PANEL-MONITOR  
134940-06-CHT  
SCREW  
G11-08-08U (4)

PANEL-MONITOR,EMS  
174295-06-000

THERMOSTAT  
000016556 / 313194-01-CHT  
000016270 / 313193-01-CHT

REMOTE PANEL-INVERTER  
(SUPPLIED W/ INVERTER)  
MODULE-12V DISCONNECT  
173355-01-000

SWITCH  
DETAIL DA

SWITCH  
DETAIL DM

2 PIN HSG  
TO SIDEWALL

WIRE ASM-OVHD  
192894-01-000

2 PIN HSG  
TO SIDEWALL

SWITCH  
DETAIL DC

TO WIRE ASM-ROOF  
DETAIL GA

TO TV  
FROM WIRE ASM-ROOF

TO TV  
FROM WIRE ASM-ROOF

SWITCH  
DETAIL DF

TO IR RECEIVER  
FROM WIRE ASM-ROOF

SWITCH  
DETAIL DK

SWITCH  
DETAIL DB

SWITCH  
DETAIL DA

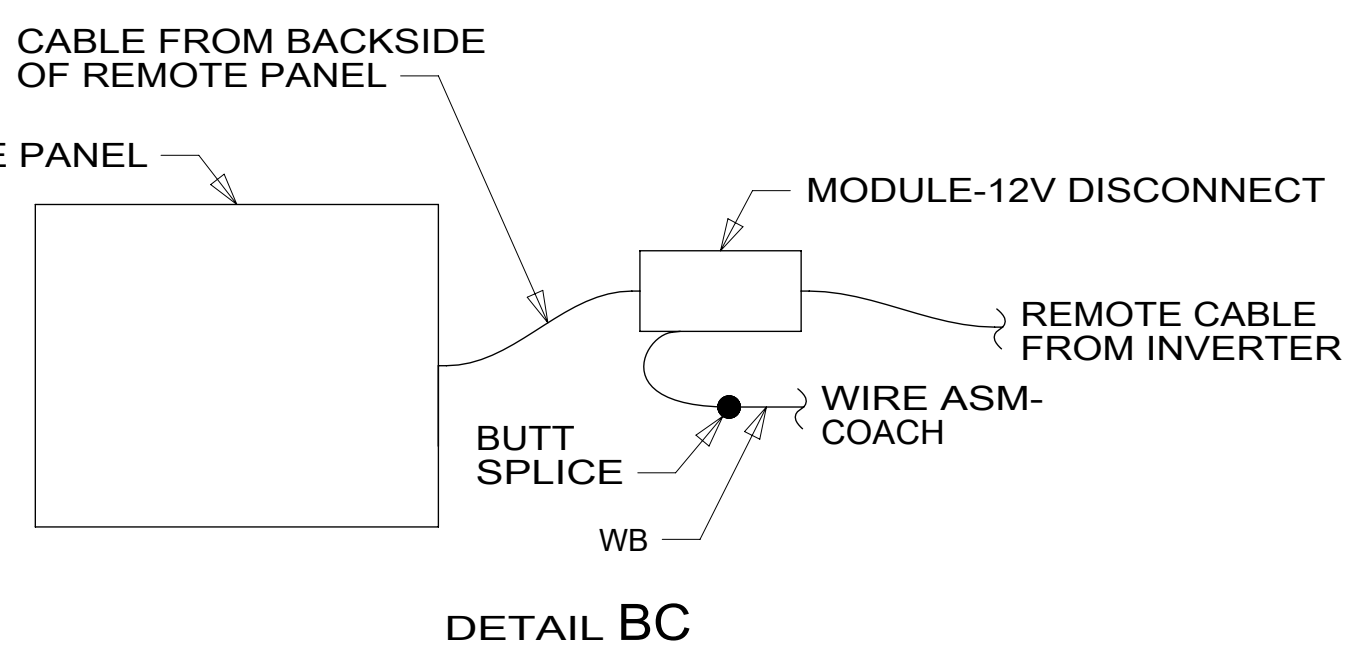

FOR ELECTRICAL  
TORQUE  
SPECIFICATIONS  
SEE DWG NO.  
128783-01-000

FOR ELECTRICAL  
CALLOUTS  
SEE DWG NO.  
121339-01-000

- 45B LOFT BED
- 401 INVERTER-DC/AC, 1000 WATT
- 29R AC HEAT PUMP-2 HI EFFICIENCY
- 276 A/C ROOF-HI EFF (2) W/EMS
- 265 CODES/STANDARDS-CSA/CMVSS
- 1B1 CODES/STANDARDS USA

NOTES:

3 DATA CABLE FOR EMS PANEL IS MARKED W/RED TAPE.

2 WIRE PASSES THROUGH FLOOR IN THIS AREA.

1. AT MINIMUM ALL WIRES TO BE SUPPORTED AND SECURED PER CODE REQUIREMENTS. USE CLAMP 10495 OR 10497 OR WIRE TIE 8343 OR 108046 AND SCREW G67-XX-XXX OR G56-XX-XXX AS APPROPRIATE FOR INSTALLATION.

DESCRIPTION:  
**WIRING INSTL-BODY, 12V**

SHEET: 2 OF 9 ITEM/PART NO: 000015237 / 31285001000 REV

14-Sep-2017

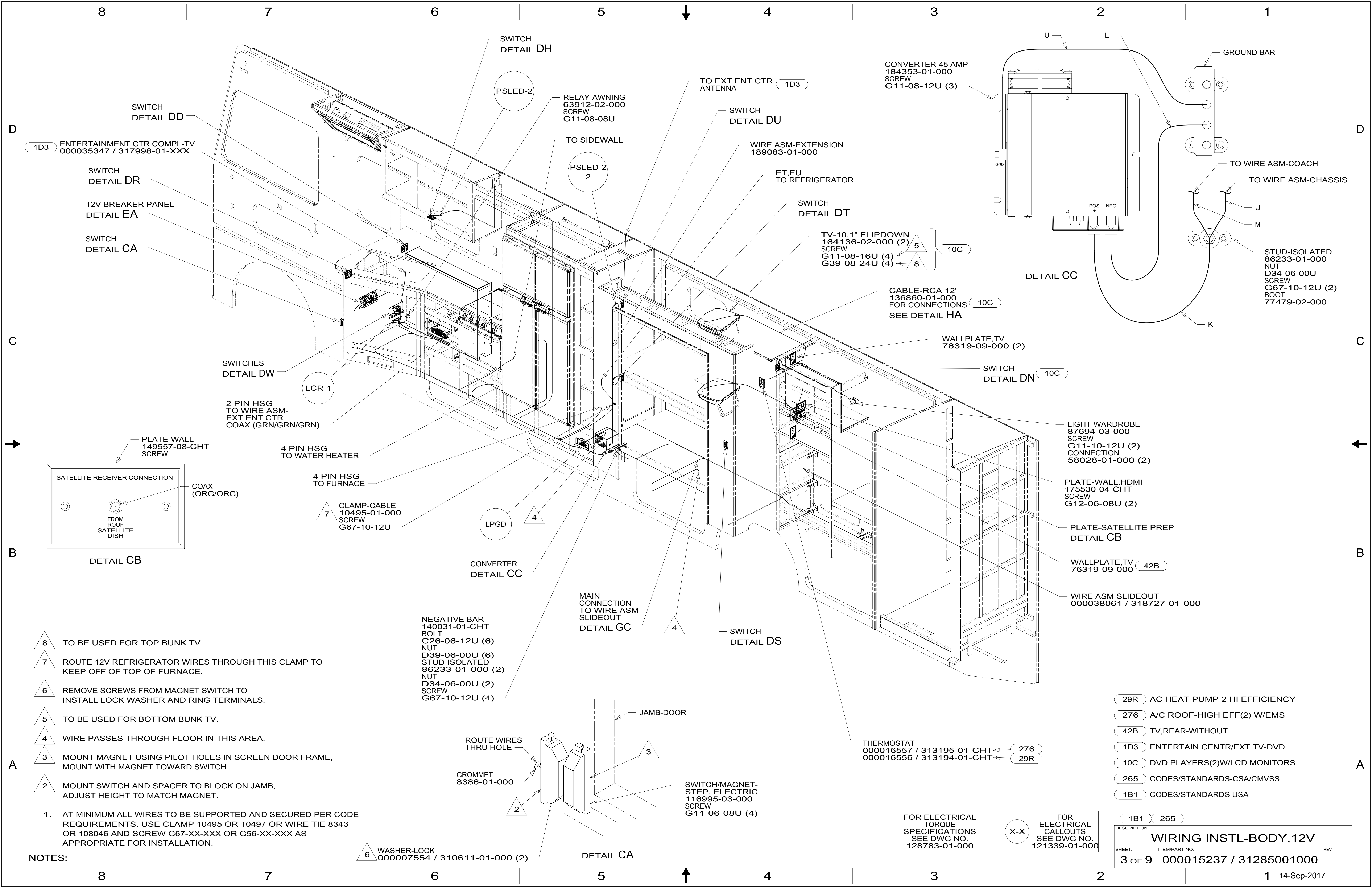

1D3 ENTERTAINMENT CTR COMPL-TV  
000035347 / 317998-01-XXX

SWITCH  
DETAIL DR

12V BREAKER PANEL  
DETAIL EA

SWITCH  
DETAIL CA

SWITCH  
DETAIL DH

PSLED-2

RELAY-AWNING  
63912-02-000  
SCREW  
G11-08-08U

TO EXT ENT CTR  
ANTENNA 1D3

SWITCH  
DETAIL DU

WIRE ASM-EXTENSION  
189083-01-000

ET,EU  
TO REFRIGERATOR

SWITCH  
DETAIL DT

TV-10.1" FLIPDOWN  
164136-02-000 (2)  
SCREW  
G11-08-16U (4)  
G39-08-24U (4)

CONVERTER-45 AMP  
184353-01-000  
SCREW  
G11-08-12U (3)

DETAIL CC

GROUND BAR

TO WIRE ASM-COACH

TO WIRE ASM-CHASSIS

J

M

STUD-ISOLATED  
86233-01-000  
NUT  
D34-06-00U  
SCREW  
G67-10-12U (2)  
BOOT  
77479-02-000

CABLE-RCA 12'  
136860-01-000  
FOR CONNECTIONS  
SEE DETAIL HA 10C

WALLPLATE,TV  
76319-09-000 (2)

SWITCH  
DETAIL DN 10C

SWITCHES  
DETAIL DW

LCR-1

2 PIN HSG  
TO WIRE ASM-  
EXT ENT CTR  
COAX (GRN/GRN/GRN)

4 PIN HSG  
TO WATER HEATER

4 PIN HSG  
TO FURNACE

CLAMP-CABLE  
10495-01-000  
SCREW  
G67-10-12U 7

LPGD 4

CONVERTER  
DETAIL CC

MAIN  
CONNECTION  
TO WIRE ASM-  
SLIDEOUT  
DETAIL GC 4

SWITCH  
DETAIL DS

LIGHT-WARDROBE  
87694-03-000  
SCREW  
G11-10-12U (2)  
CONNECTION  
58028-01-000 (2)

PLATE-WALL,HDMI  
175530-04-CHT  
SCREW  
G12-06-08U (2)

PLATE-SATELLITE PREP  
DETAIL CB

WALLPLATE,TV  
76319-09-000 42B

WIRE ASM-SLIDEOUT  
000038061 / 318727-01-000

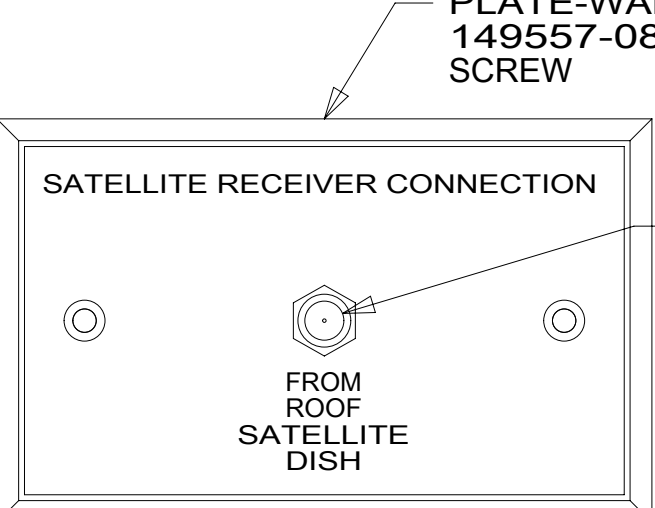

DETAIL CB

- 8 TO BE USED FOR TOP BUNK TV.
- 7 ROUTE 12V REFRIGERATOR WIRES THROUGH THIS CLAMP TO KEEP OFF OF TOP OF FURNACE.
- 6 REMOVE SCREWS FROM MAGNET SWITCH TO INSTALL LOCK WASHER AND RING TERMINALS.
- 5 TO BE USED FOR BOTTOM BUNK TV.
- 4 WIRE PASSES THROUGH FLOOR IN THIS AREA.
- 3 MOUNT MAGNET USING PILOT HOLES IN SCREEN DOOR FRAME, MOUNT WITH MAGNET TOWARD SWITCH.
- 2 MOUNT SWITCH AND SPACER TO BLOCK ON JAMB, ADJUST HEIGHT TO MATCH MAGNET.

1. AT MINIMUM ALL WIRES TO BE SUPPORTED AND SECURED PER CODE REQUIREMENTS. USE CLAMP 10495 OR 10497 OR WIRE TIE 8343 OR 108046 AND SCREW G67-XX-XXX OR G56-XX-XXX AS APPROPRIATE FOR INSTALLATION.

NOTES:

NEGATIVE BAR  
140031-01-CHT  
BOLT  
C26-06-12U (6)  
NUT  
D39-06-00U (6)  
STUD-ISOLATED  
86233-01-000 (2)  
NUT  
D34-06-00U (2)  
SCREW  
G67-10-12U (4)

JAMB-DOOR

ROUTE WIRES  
THRU HOLE

GROMMET  
8386-01-000

2

3

SWITCH/MAGNET-  
STEP, ELECTRIC  
116995-03-000  
SCREW  
G11-06-08U (4)

THERMOSTAT  
000016557 / 313195-01-CHT 276  
000016556 / 313194-01-CHT 29R

FOR ELECTRICAL  
TORQUE  
SPECIFICATIONS  
SEE DWG NO.  
128783-01-000

FOR  
ELECTRICAL  
CALLOUTS  
SEE DWG NO.  
121339-01-000

- 29R AC HEAT PUMP-2 HI EFFICIENCY
- 276 A/C ROOF-HIGH EFF(2) W/EMS
- 42B TV,REAR-WITHOUT
- 1D3 ENTERTAIN CENTR/EXT TV-DVD
- 10C DVD PLAYERS(2)W/LCD MONITORS
- 265 CODES/STANDARDS-CSA/CMVSS
- 1B1 CODES/STANDARDS USA

DESCRIPTION: <b>WIRING INSTL-BODY, 12V</b>	
SHEET: 3 OF 9	ITEM/PART NO: 000015237 / 31285001000
REV	

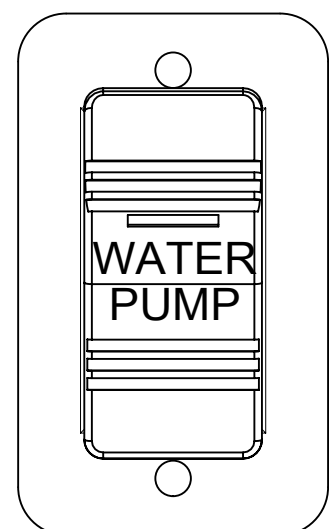

SWITCH-PUMP  
108357-15-000  
ACTUATOR  
108356-23-CHT  
PLATE  
98351-07-CHT  
SCREW  
G11-06-10U (2)

DETAIL DA  
(2 PLACES)

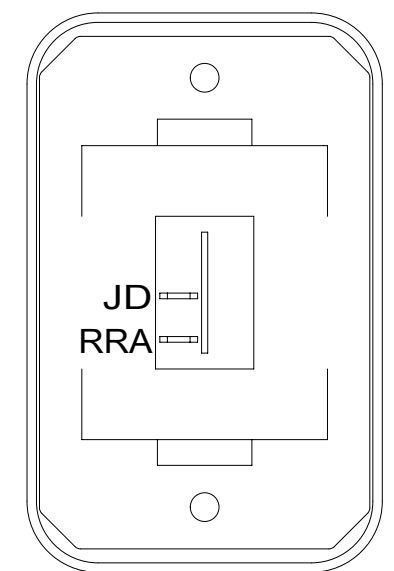

SWITCH-ROCKER  
135740-01-CHT  
SWITCH-BASE  
135741-01-CHT  
SWITCH-BEZEL  
135742-01-CHT  
SCREW  
G11-08-08U (2)

DETAIL DF

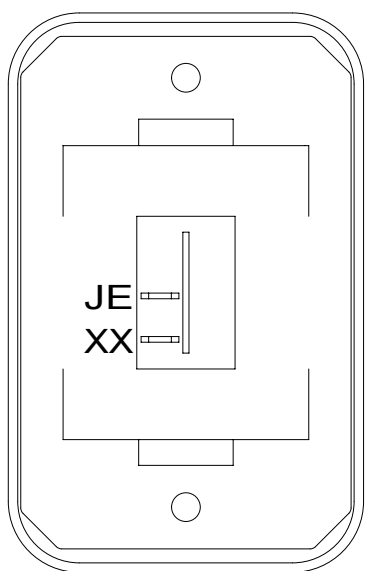

SWITCH-ROCKER  
135740-01-CHT  
SWITCH-BASE  
135741-01-CHT  
SWITCH-BEZEL  
135742-01-CHT  
SCREW  
G11-08-08U (2)

DETAIL DJ

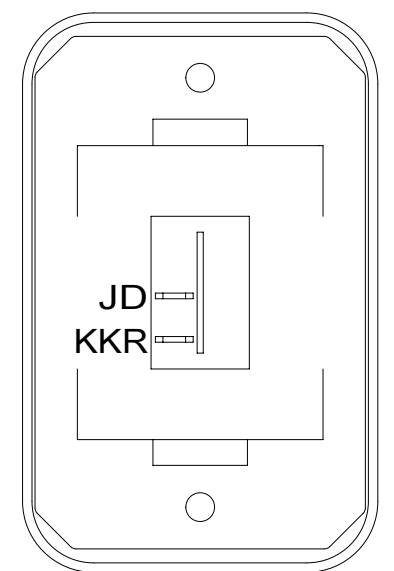

SWITCH-ROCKER  
135740-01-CHT  
SWITCH-BASE  
135741-01-CHT  
SWITCH-BEZEL  
135742-01-CHT  
SCREW  
G11-08-08U (2)

DETAIL DM

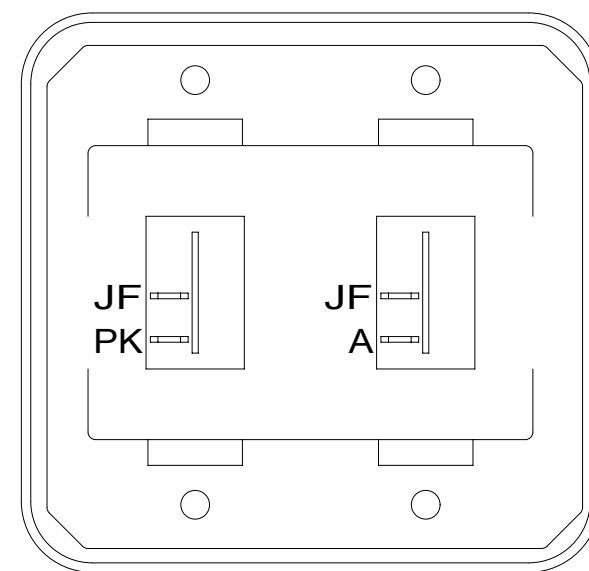

SWITCH-ROCKER  
135740-01-CHT (2)  
SWITCH-BASE  
135741-02-CHT  
SWITCH-BEZEL  
135742-02-CHT  
SCREW  
G11-08-08U (4)

DETAIL DR

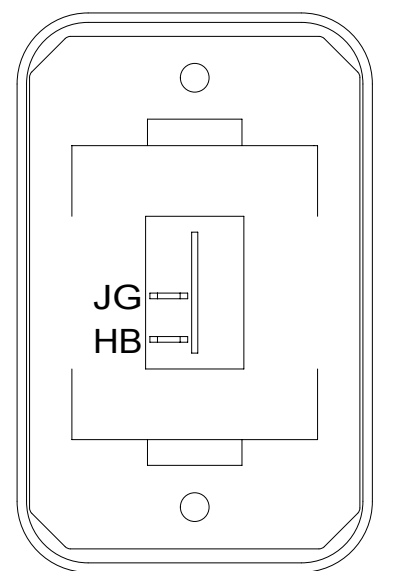

SWITCH-ROCKER  
135740-01-CHT  
SWITCH-BASE  
135741-01-CHT  
SWITCH-BEZEL  
135742-01-CHT  
SCREW  
G11-08-08U (2)

DETAIL DU

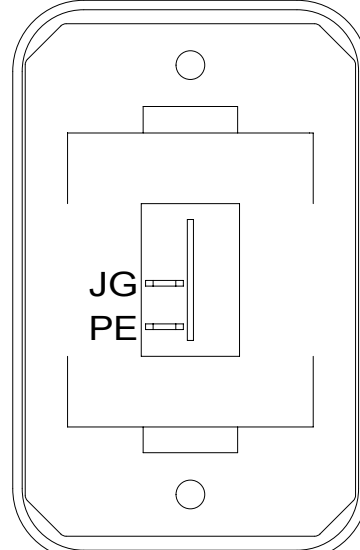

SWITCH-ROCKER  
135740-01-CHT  
SWITCH-BASE  
135741-01-CHT  
SWITCH-BEZEL  
135742-01-CHT  
SCREW  
G11-08-08U (2)

DETAIL DB

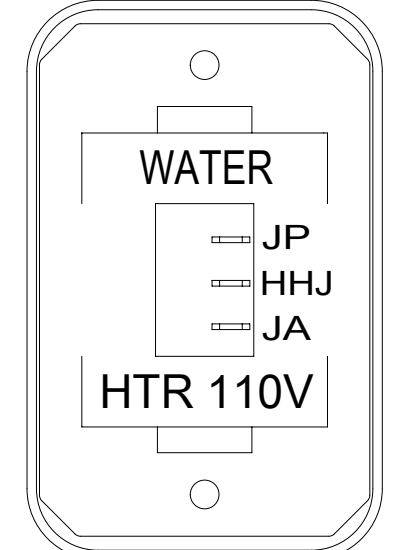

SWITCH-ROCKER  
135740-06-CHT  
SWITCH-BASE  
135741-01-CHT  
SWITCH-BEZEL  
135742-35-CHT  
SCREW  
G11-08-08U (2)

DETAIL DG 53D

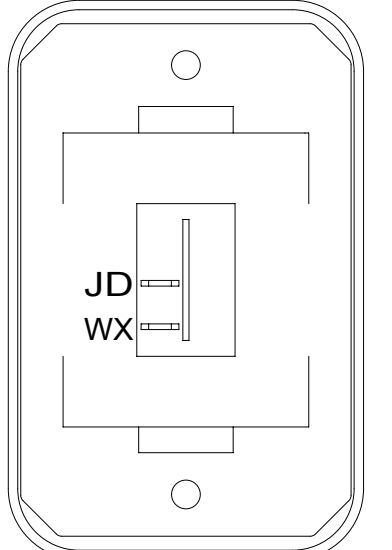

SWITCH-ROCKER  
135740-01-CHT  
SWITCH-BASE  
135741-01-CHT  
SWITCH-BEZEL  
135742-01-CHT  
SCREW  
G11-08-08U (2)

DETAIL DK

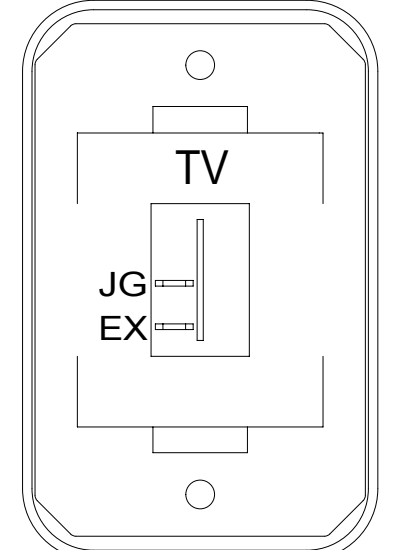

SWITCH-ROCKER  
135740-01-CHT  
SWITCH-BASE  
135741-01-CHT  
SWITCH-BEZEL  
135742-45-CHT  
SCREW  
G11-08-08U (2)

DETAIL DN 10C

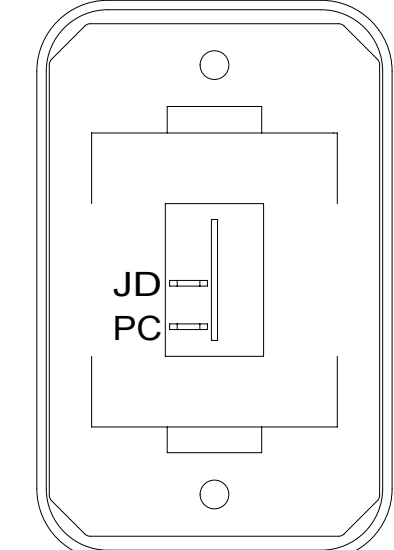

SWITCH-ROCKER  
135740-01-CHT  
SWITCH-BASE  
135741-01-CHT  
SWITCH-BEZEL  
135742-01-CHT  
SCREW  
G11-08-08U (2)

DETAIL DS

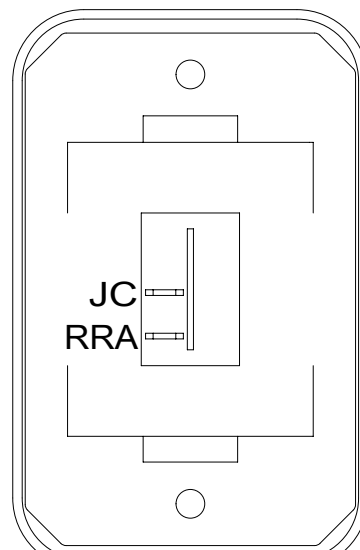

SWITCH-ROCKER  
135740-01-CHT  
SWITCH-BASE  
135741-01-CHT  
SWITCH-BEZEL  
135742-01-CHT  
SCREW  
G11-08-08U (2)

DETAIL DC

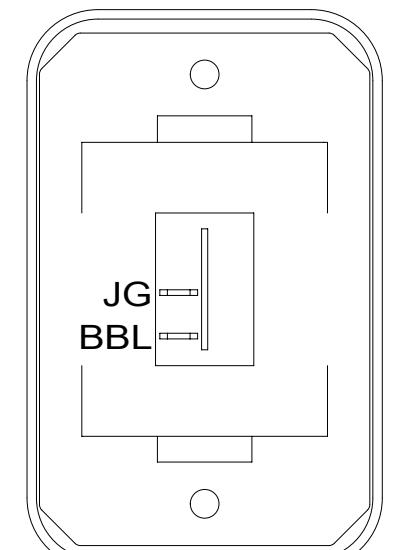

SWITCH-ROCKER  
135740-01-CHT  
SWITCH-BASE  
135741-01-CHT  
SWITCH-BEZEL  
135742-01-CHT  
SCREW  
G11-08-08U (2)

DETAIL DH

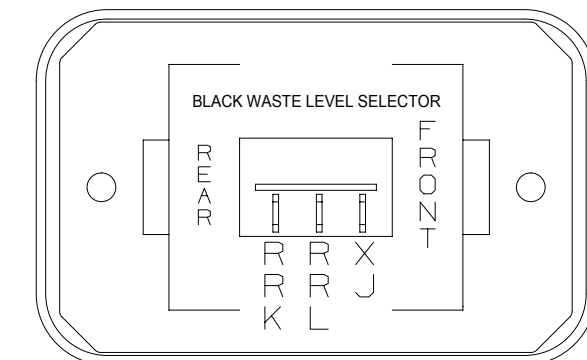

SWITCH-ROCKER  
135740-02-CHT  
SWITCH-BASE  
135741-01-CHT  
SWITCH-BEZEL  
135742-61-CHT  
SCREW  
G11-08-08U (2)

DETAIL DL

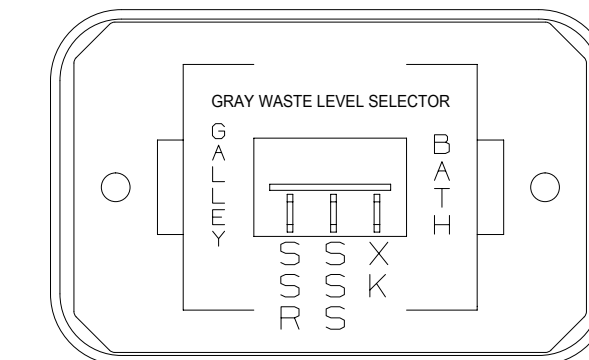

SWITCH-ROCKER  
135740-02-CHT  
SWITCH-BASE  
135741-01-CHT  
SWITCH-BEZEL  
135742-52-CHT  
SCREW  
G11-08-08U (2)

DETAIL DP

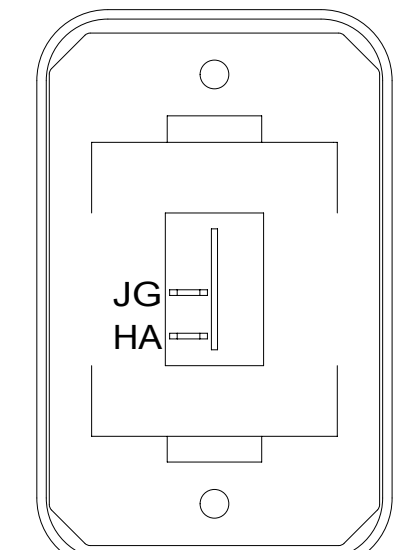

SWITCH-ROCKER  
135740-01-CHT  
SWITCH-BASE  
135741-01-CHT  
SWITCH-BEZEL  
135742-01-CHT  
SCREW  
G11-08-08U (2)

DETAIL DT

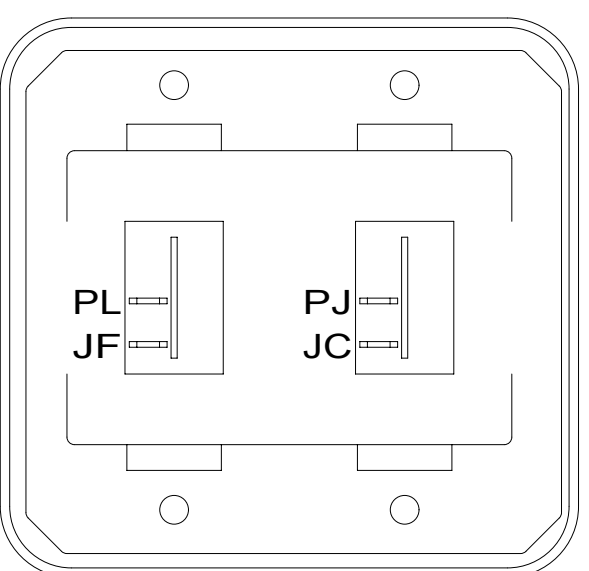

SWITCH-ROCKER  
135740-01-CHT (2)  
SWITCH-BASE  
135741-02-CHT  
SWITCH-BEZEL  
135742-02-CHT  
SCREW  
G11-08-08U (4)

DETAIL DD

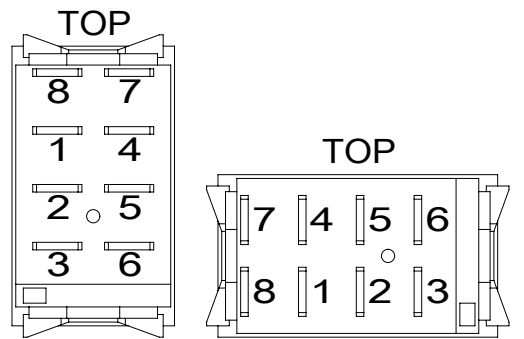

DETAIL DE

SWITCH  
108357-18-000  
ACTUATOR  
108356-31-CHT  
CIRCUITS  
BBN,KE,BBM,ABW,ABX

LABEL-WARNING,SLIDEOUT  
116549-01-000

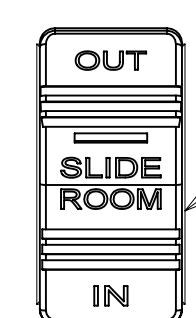
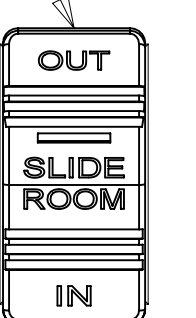
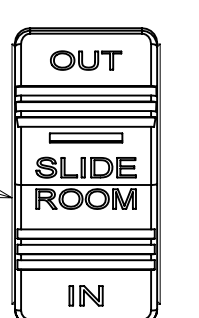
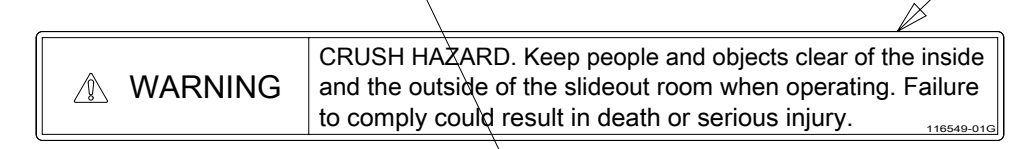

SWITCH  
108357-18-000  
ACTUATOR  
108356-31-CHT  
CIRCUITS  
DU,KE,DR,ABY,ABZ

SWITCH  
108357-18-000  
ACTUATOR  
108356-31-CHT  
CIRCUITS  
HHH,KE,HHG,ACC,ACD

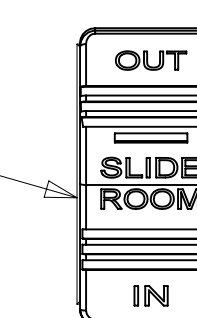

LABEL-SLIDEOUT  
PASS,REAR  
163992-03-CHT



LABEL-SLIDEOUT,  
DRIVER,REAR  
163992-02-CHT



LABEL-SLIDEOUT,  
DRIVER,FRONT  
163992-01-CHT



DETAIL DV

SWITCH-AWNING  
108357-06-000  
ACTUATOR-SWITCH  
108356-12-CHT  
CIRCUITS  
FFD,FFR,FFE,  
FFE,JJR,FFD

SWITCH-AWNING LIGHT  
108357-14-000  
ACTUATOR-SWITCH  
108356-28-CHT  
CIRCUITS  
SP,ZZL,  
WE,ZZL

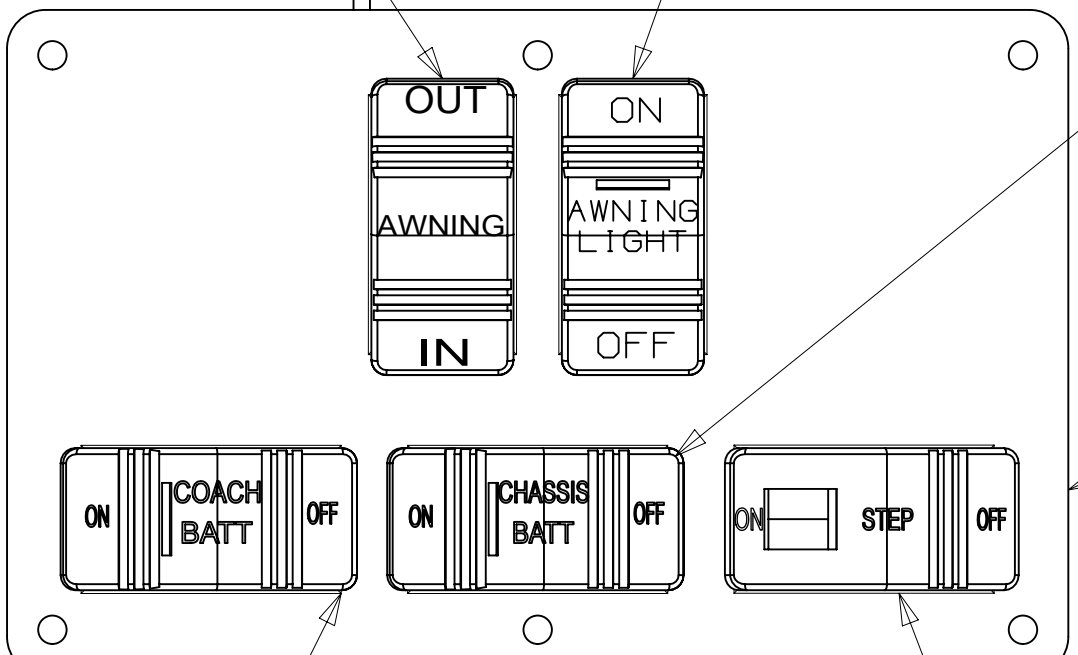

SWITCH-CHASSIS BATTERY  
108357-18-000  
ACTUATOR-SWITCH  
108356-20-CHT  
CIRCUITS  
UUC,TTY,UUB  
UUB,TTZ,MK  
WIRE ASM-THERM  
186796-01-000

PLATE-SWITCH  
158431-04-CHT  
SCREW  
G11-06-10U (6)

SWITCH-COACH BATT  
108357-18-000  
ACTUATOR-SWITCH  
108356-19-CHT  
CIRCUITS  
KF,LG,LJ,LH,WC  
WIRE ASM-THERM  
186796-01-000

SWITCH-STEP  
108357-19-000  
CIRCUITS  
ER,ES

DETAIL DW 1

FOR ELECTRICAL  
TORQUE  
SPECIFICATIONS  
SEE DWG NO.  
128783-01-000

FOR ELECTRICAL  
CALLOUTS  
SEE DWG NO.  
121339-01-000

- 10C DVD PLAYERS(2)W/LCD MONITORS
- 53D WTR HTR-6GAL/ELE/LP/MOTORAID
- 265 CODES/STANDARDS-CSA/CMVSS
- 1B1 CODES/STANDARDS USA

DESCRIPTION: <b>WIRING INSTL-BODY, 12V</b>	
SHEET: 4 OF 9	ITEM/PART NO: 000015237 / 31285001000
REV	

NOTES:  
1 FOR SWITCH ORIENTATION SEE DETAIL DE

8 7 6 5 4 3 2 1

D

D

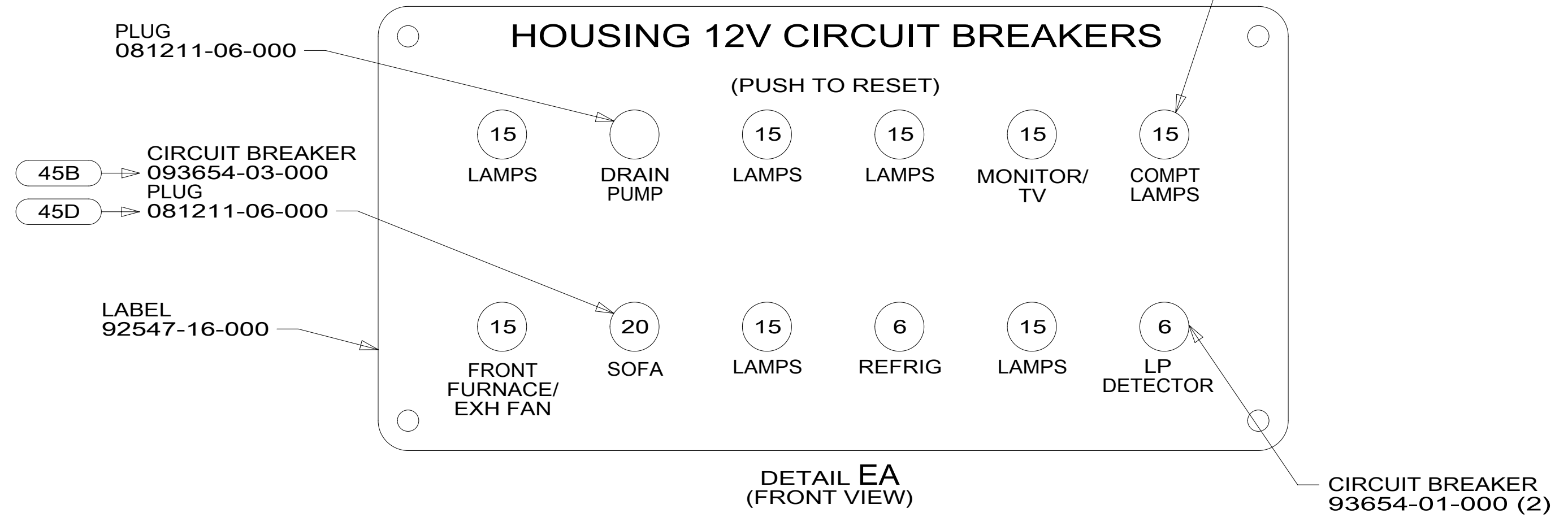
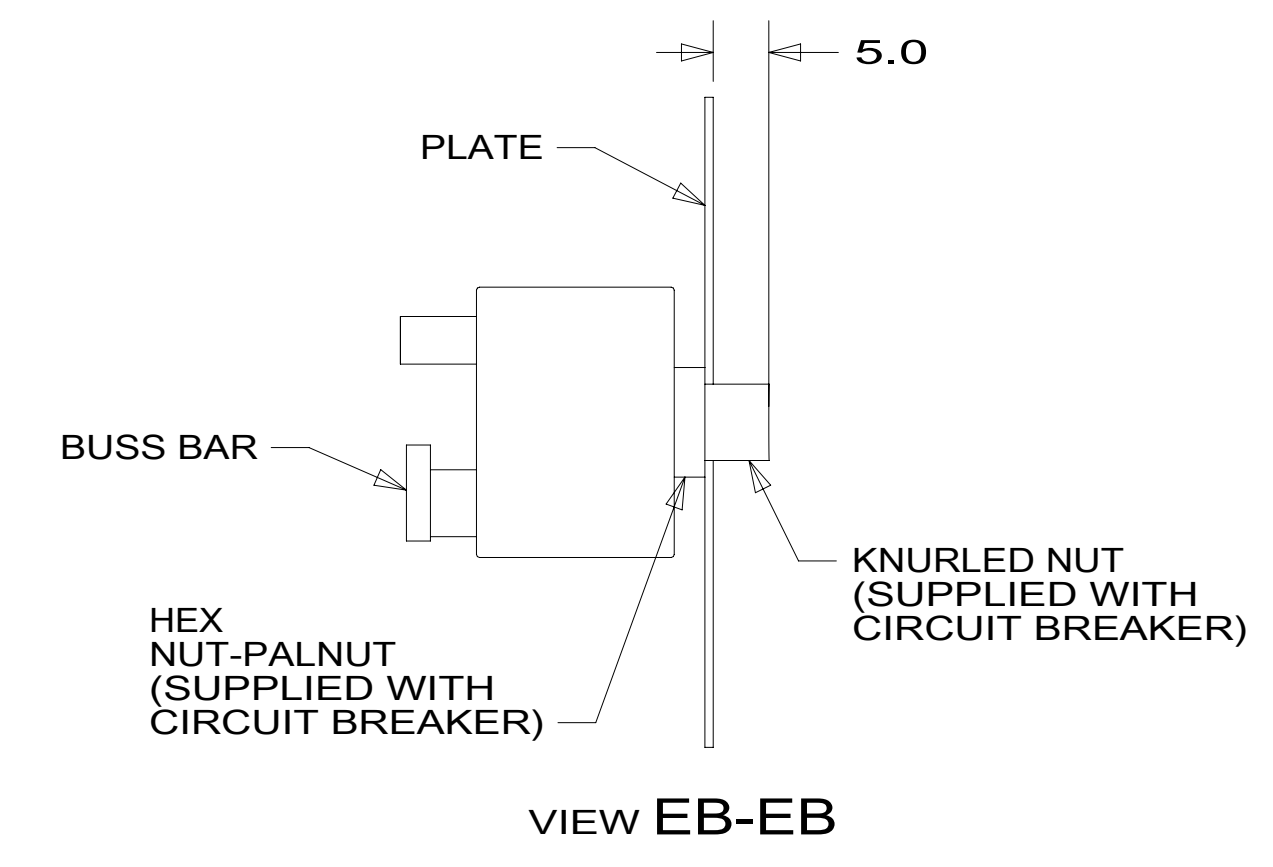
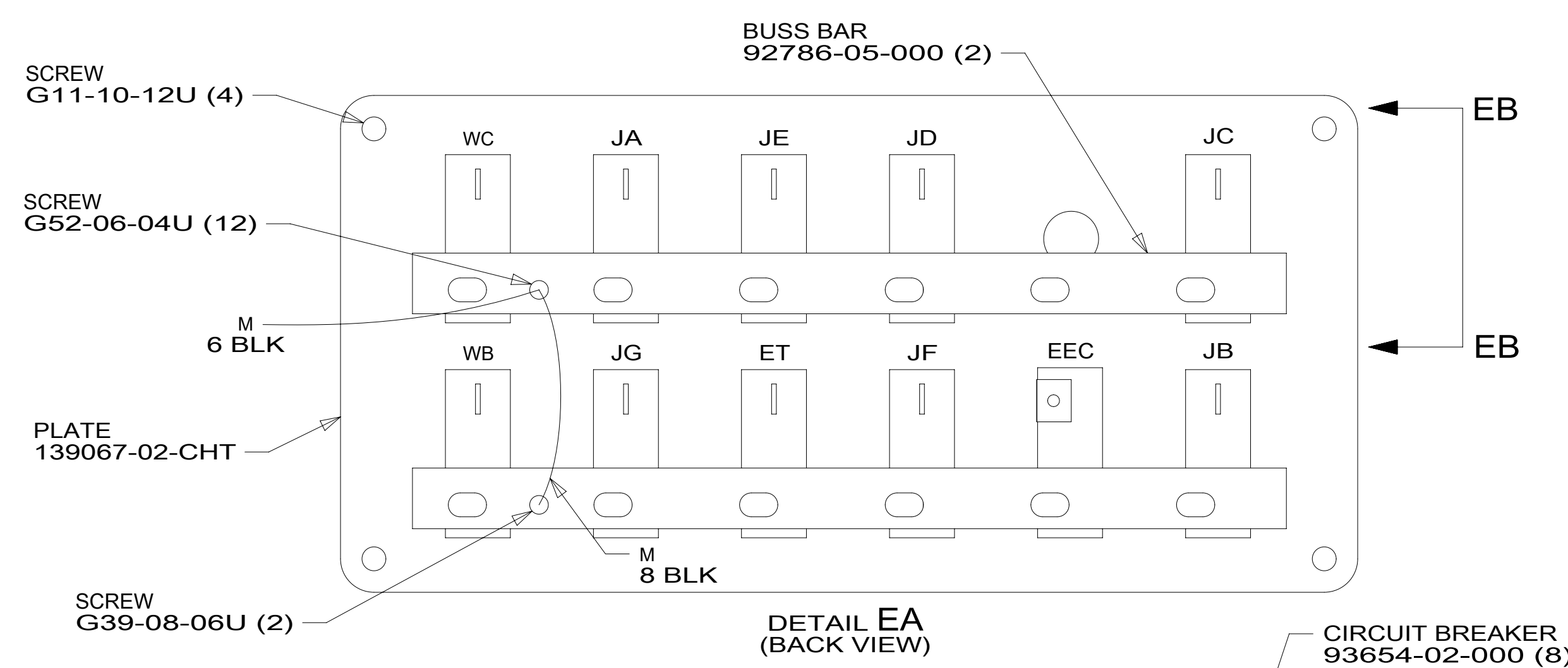

→

←

B

B

A

A

8 7 6 5 4 3 2 1

- 45D LOFT BED - WITHOUT
- 45B LOFT BED
- 265 CODES/STANDARDS-CSA/CMVSS
- 1B1 CODES/STANDARDS USA

FOR ELECTRICAL TORQUE SPECIFICATIONS SEE DWG NO. 128783-01-000

FOR ELECTRICAL CALLOUTS SEE DWG NO. 121339-01-000

DESCRIPTION: <b>WIRING INSTL-BODY, 12V</b>		
SHEET: 5 OF 9	ITEM/PART NO: 000015237 / 31285001000	REV

8 7 6 5 4 3 2 1

D  
C  
B  
A

D  
C  
B  
A

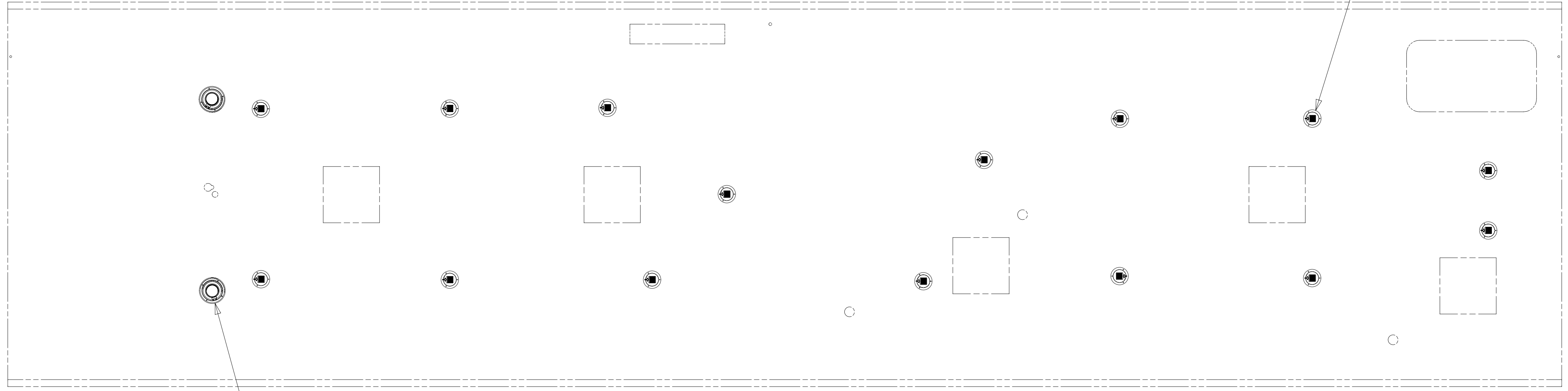

SPEAKER-ROUND, CEILING  
 180783-01-CHT (2)  
 SCREW  
 G11-08-12U (8)

PRLED-4  
 15

FOR ELECTRICAL  
 TORQUE  
 SPECIFICATIONS  
 SEE DWG NO.  
 128783-01-000

FOR  
 ELECTRICAL  
 CALLOUTS  
 SEE DWG NO.  
 121339-01-000

265 CODES/STANDARDS-CSA/CMVSS  
 1B1 CODES/STANDARDS USA

DESCRIPTION:	
1B1 265	
<b>WIRING INSTL-BODY, 12V</b>	
SHEET:	ITEM/PART NO:
6 OF 9	000015237 / 31285001000

8 7 6 5 4 3 2 1

8 7 6 5 4 3 2 1



D

D

C

C

B

B

A

A



8

7

6

5

4

3

2

1

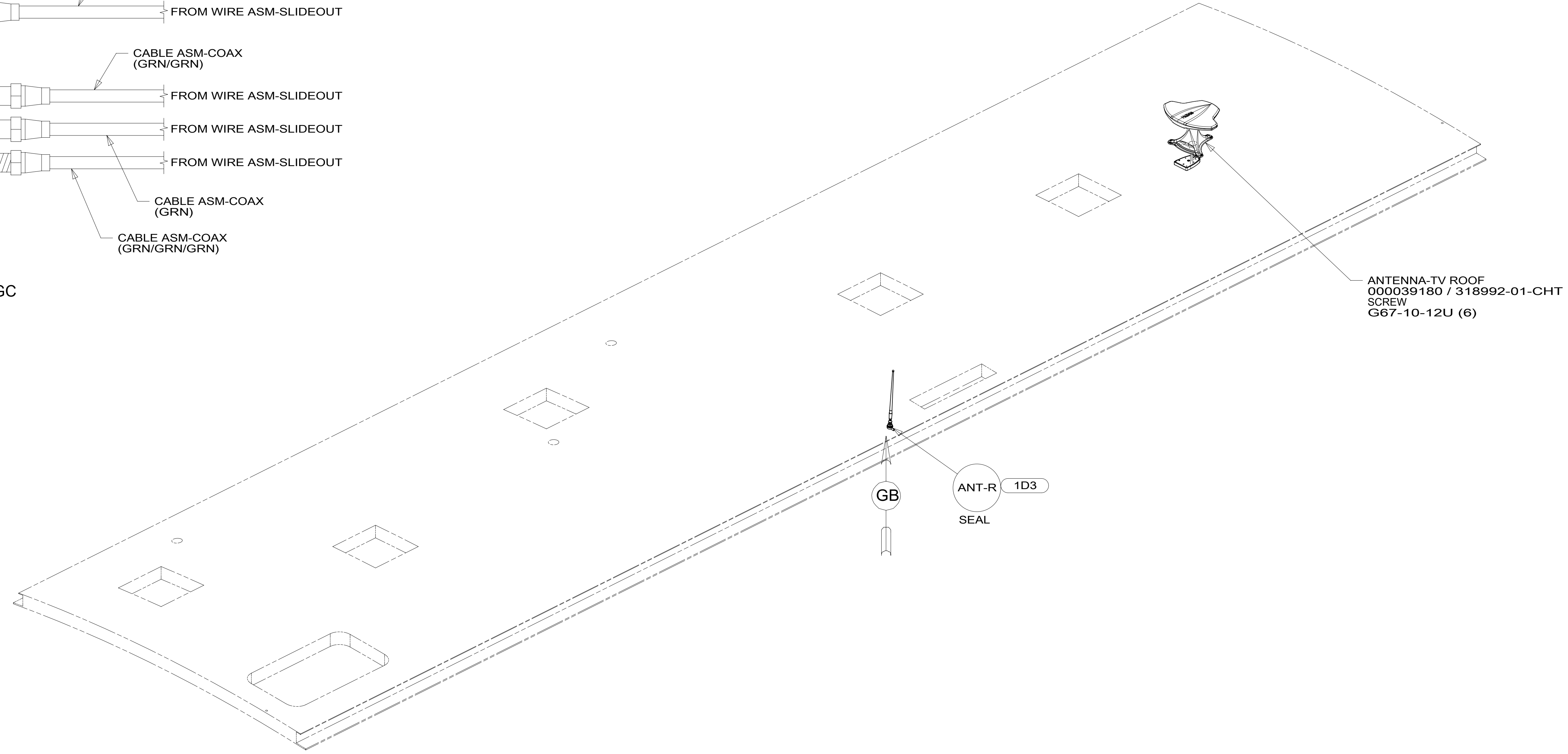
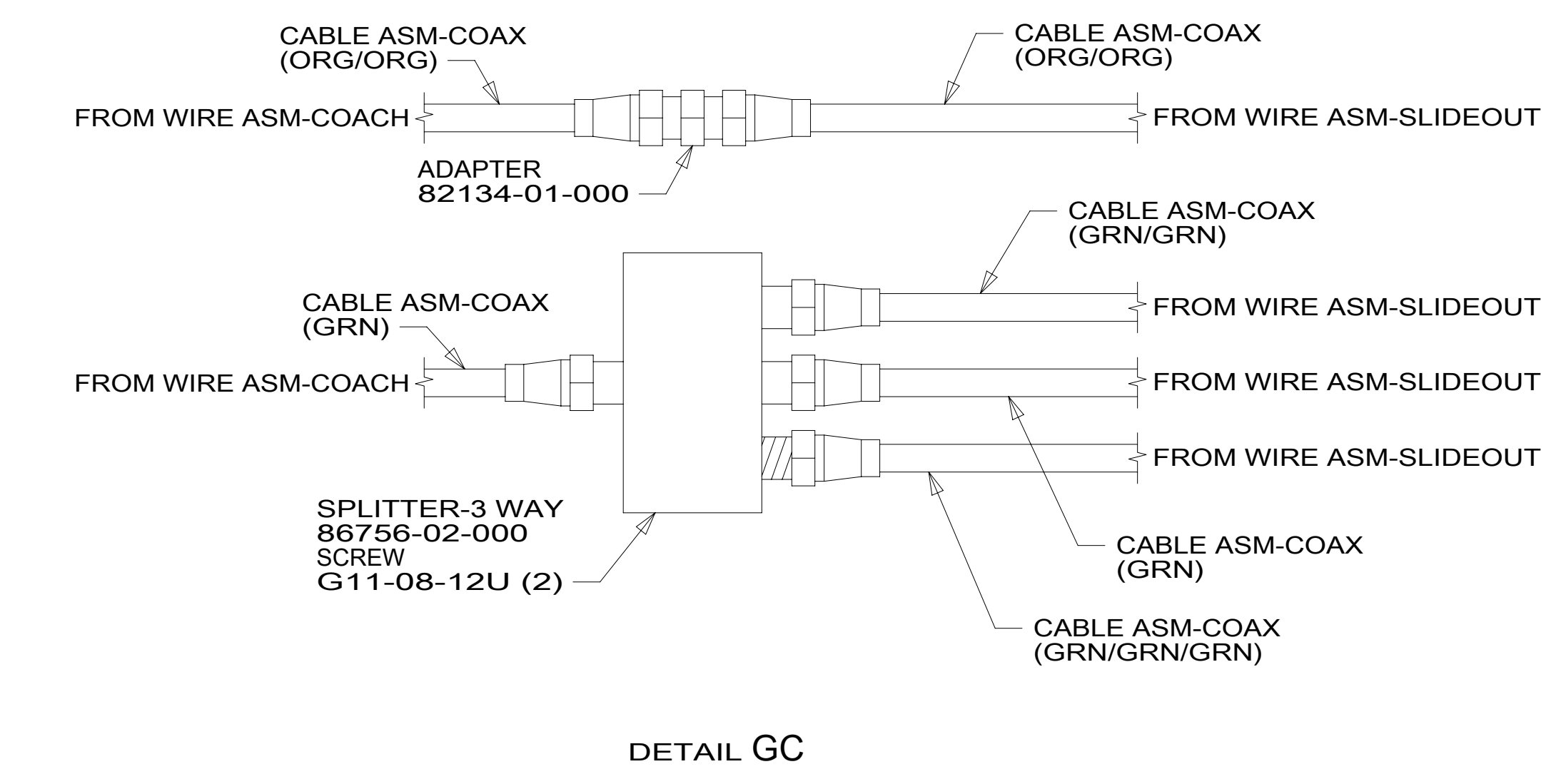
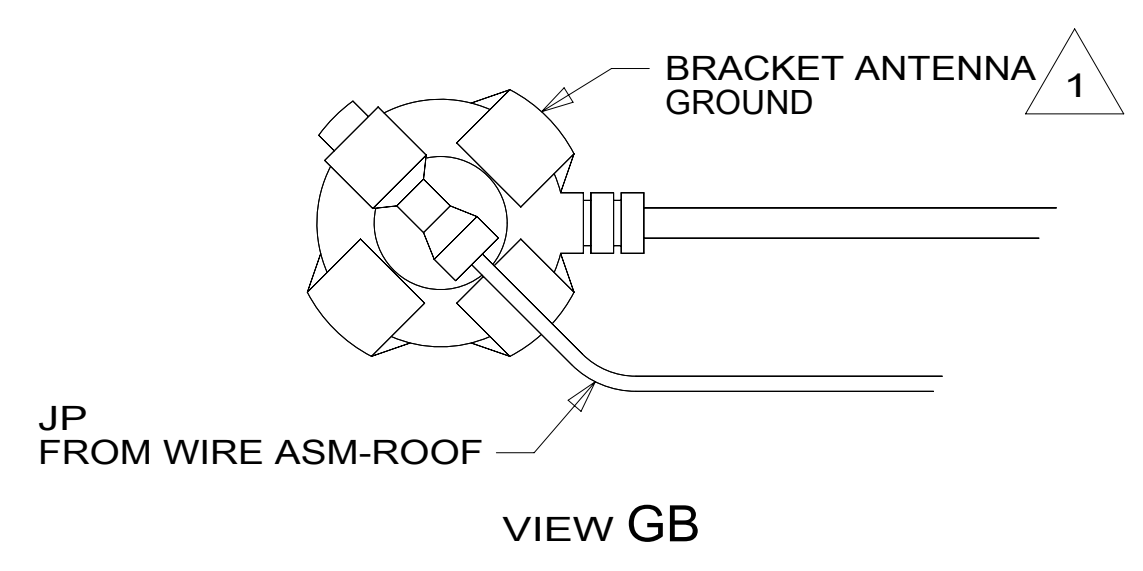
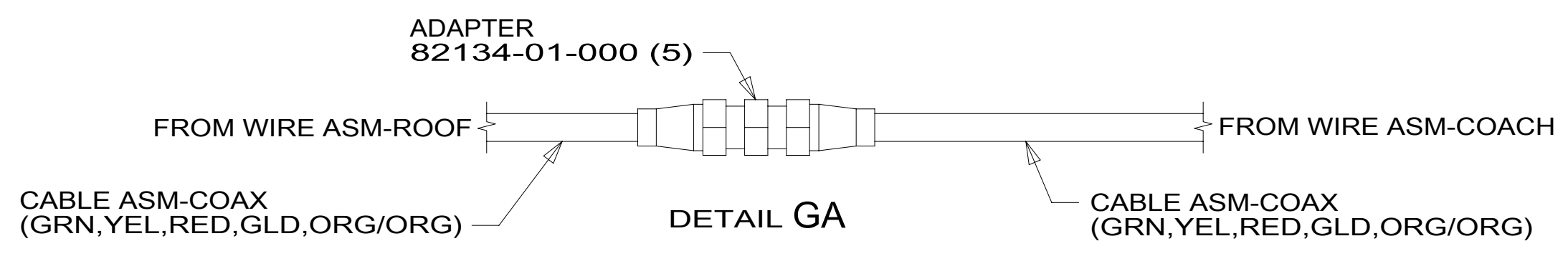

NOTES:  
 1 WRAP LEGS AROUND ANTENNA BASE.

FOR ELECTRICAL TORQUE SPECIFICATIONS SEE DWG NO. 128783-01-000

FOR ELECTRICAL CALLOUTS SEE DWG NO. 121339-01-000

- 1D3 ENTERTAIN CENTR/EXT TV-DVD
- 265 CODES/STANDARDS-CSA/CMVSS
- 1B1 CODES/STANDARDS USA

DESCRIPTION: <b>WIRING INSTL-BODY, 12V</b>		
SHEET: 7 OF 9	ITEM/PART NO: 000015237 / 31285001000	REV

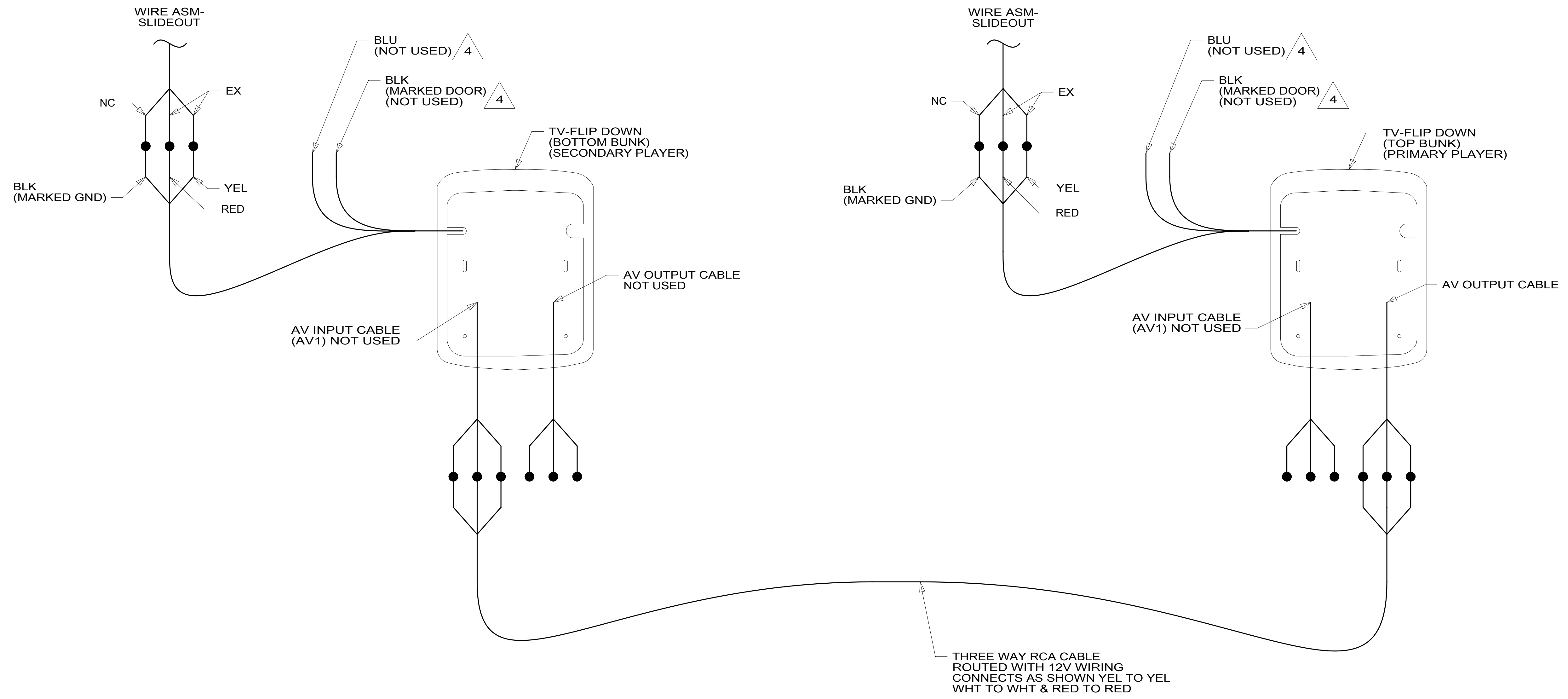

DETAIL HA 10C

- 4 CRIMP BUTT CONNECTOR 112823-01-000 ON THE END OF UNUSED WIRES.
3. REMOVE SHIPPING RESTRAINT SCREWS FROM DVD PLAYER AND DISCARD STEEL MOUNTING PLATE.
  2. REMOTE IR RECEIVER SUPPLIED WITH DVD PLAYER, TO BE MOUNTED IN BOTTOM BUNK.
  1. AT MINIMUM ALL WIRES TO BE SUPPORTED AND SECURED PER CODE REQUIREMENTS. USE CLAMP 10495 OR 10497 OR WIRE TIE 8343 OR 108046 AND SCREW G67-XX-XXX OR G56-XX-XXX AS APPROPRIATE FOR INSTALLATION.

NOTES:

- 10C DVD PLAYER W/7" MONITOR
- 265 CODES/STANDARDS-CSA/CMVSS
- 1B1 CODES/STANDARDS USA

FOR ELECTRICAL TORQUE SPECIFICATIONS SEE DWG NO. 128783-01-000

FOR ELECTRICAL CALLOUTS SEE DWG NO. 121339-01-000

DESCRIPTION:	
1B1 265	
WIRING INSTL-BODY, 12V	
SHEET:	ITEM/PART NO:
8 OF 9	000015237 / 31285001000
REV	



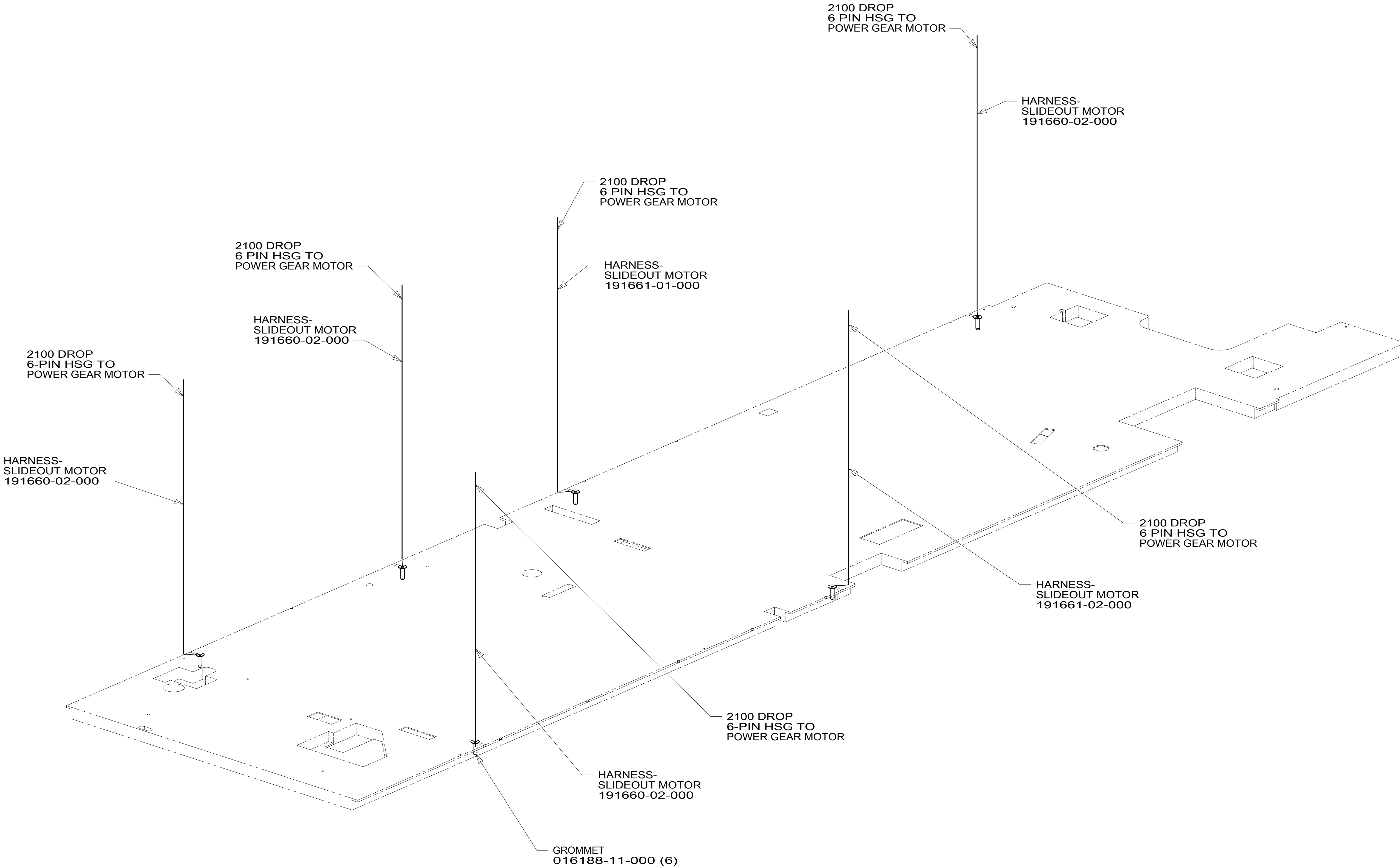
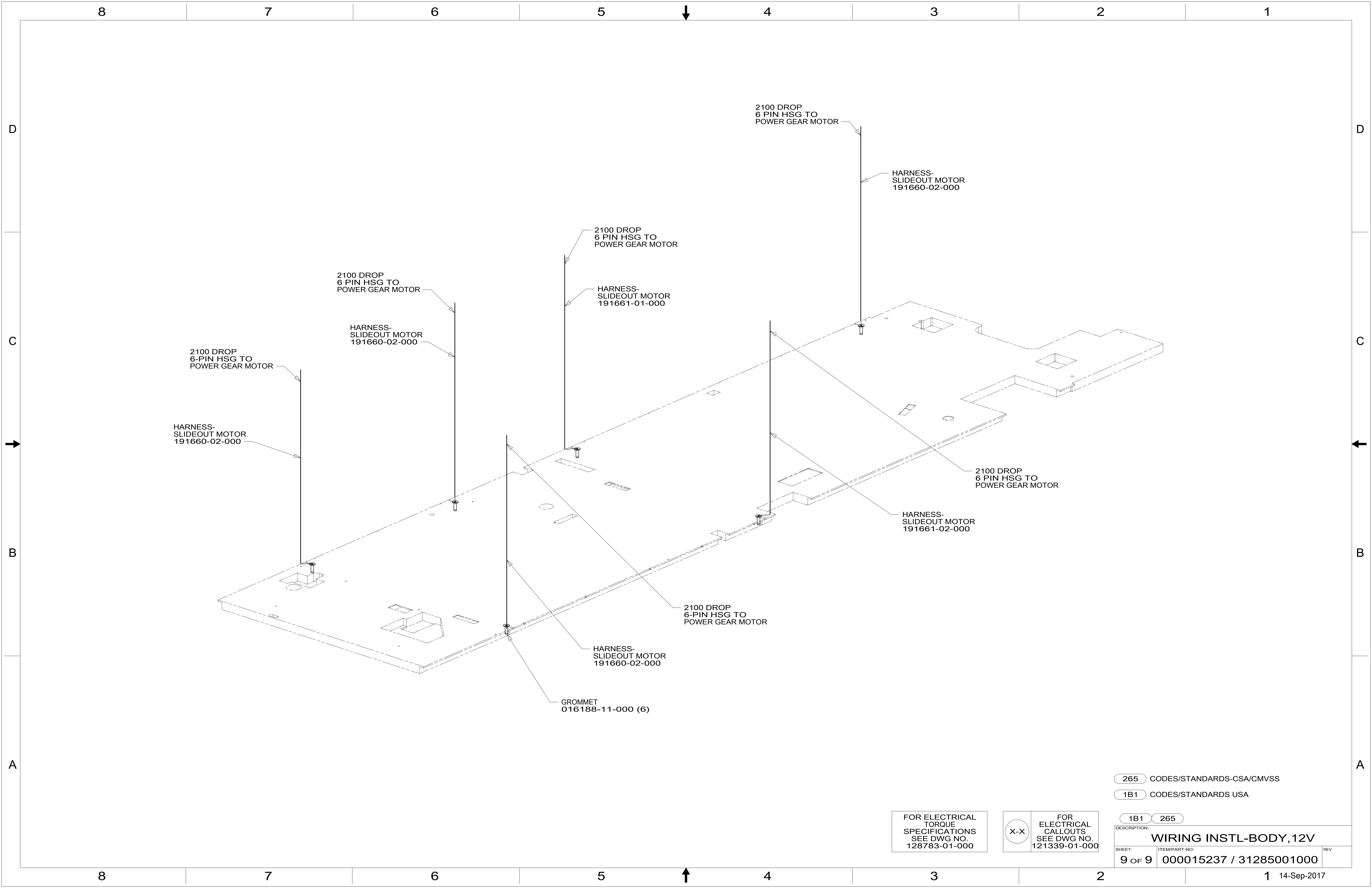

265 CODES/STANDARDS-CSA/CMVSS  
 1B1 CODES/STANDARDS USA

FOR ELECTRICAL TORQUE SPECIFICATIONS SEE DWG NO. 128783-01-000

FOR ELECTRICAL CALLOUTS SEE DWG NO. 121339-01-000

DESCRIPTION:	
1B1 265	
<b>WIRING INSTL-BODY, 12V</b>	
SHEET:	ITEM/PART NO:
9 OF 9	000015237 / 31285001000
REV	
1 14-Sep-2017	