

8 7 6 5 4 3 2 1

D
C
B
A

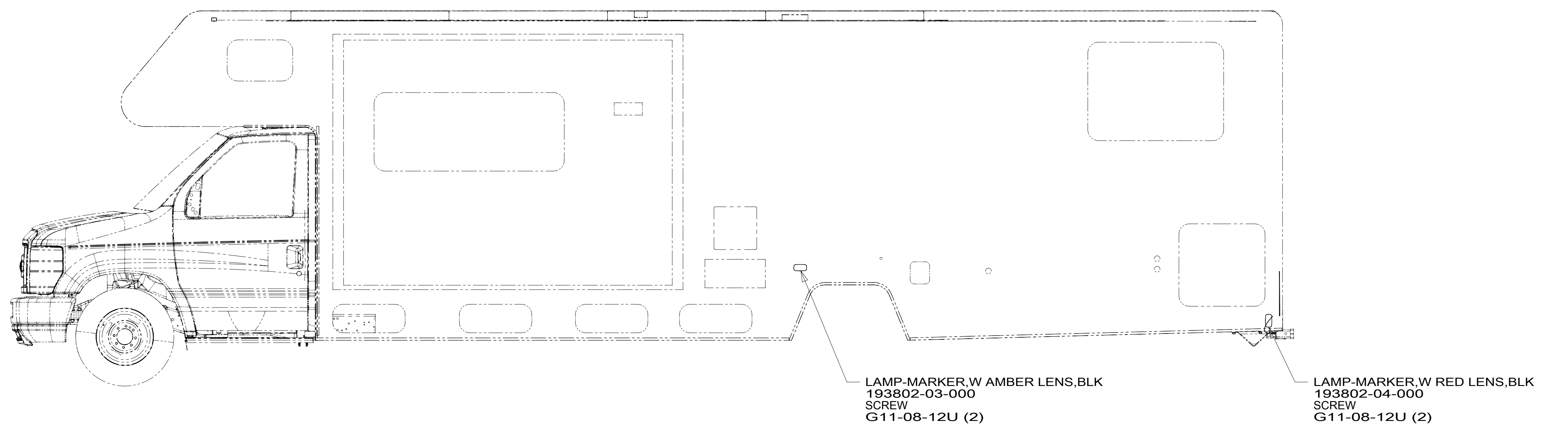

- 265 CODES/STANDARDS-CSA/CMVSS
- 1B1 CODES/STANDARDS USA
- 1B1 265

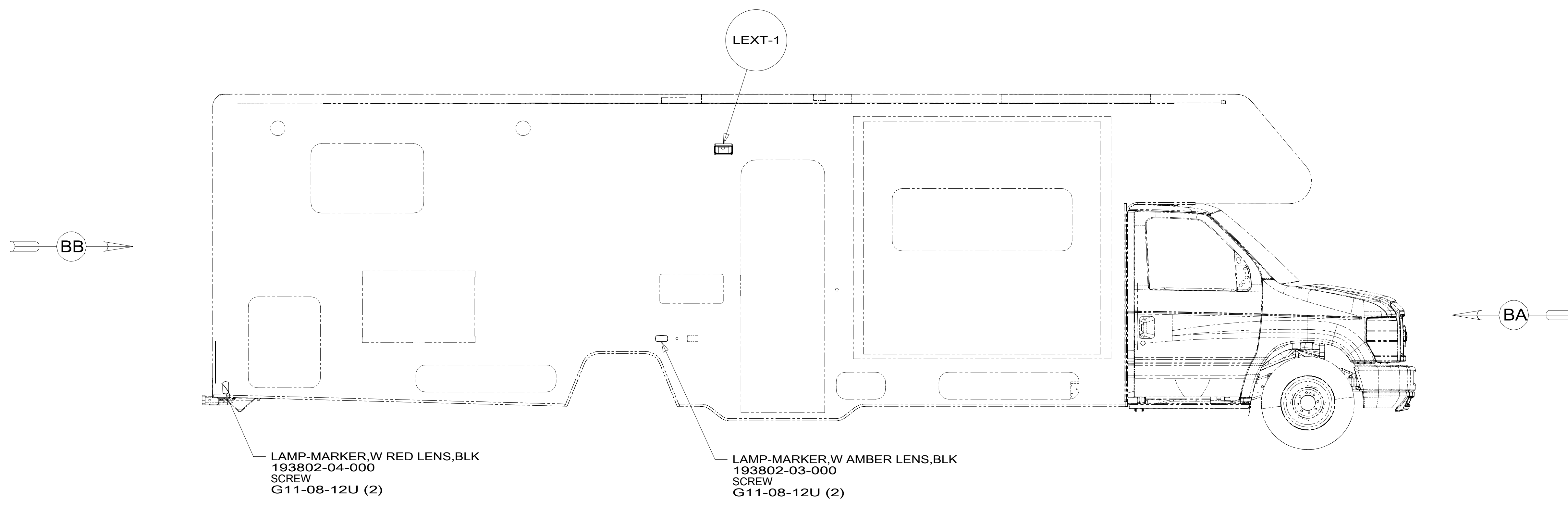

DSNR:	ALL DIMENSIONS ARE IN MILLIMETERS	
DIFFR:	MATERIAL:	
UNSPECIFIED TOLERANCES:		
WHOLE DIM (X)	: 3	
ONE-PLACE (X.X)	: 1.5	
TWO-PLACE (X.XX)	: 0.50	
ANGLE	: 1°	
REFER TO ES0018 FOR FASTENER TIGHTENING GUIDELINES	WEIGHT: (LBS)	FIRST USED:
		17 331D

FOR ELECTRICAL TORQUE SPECIFICATIONS SEE DWG NO. 128783-01-000

FOR ELECTRICAL CALLOUTS SEE DWG NO. 121339-01-000

WIRING INSTL-EXTERIOR LAMPS

SHEET: 1 OF 2 ITEM/PART NO: 000004945 / 31220301000 REV

8 7 6 5 4 3 2 1

D
C
B
A

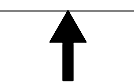

8 7 6 5 4 3 2 1

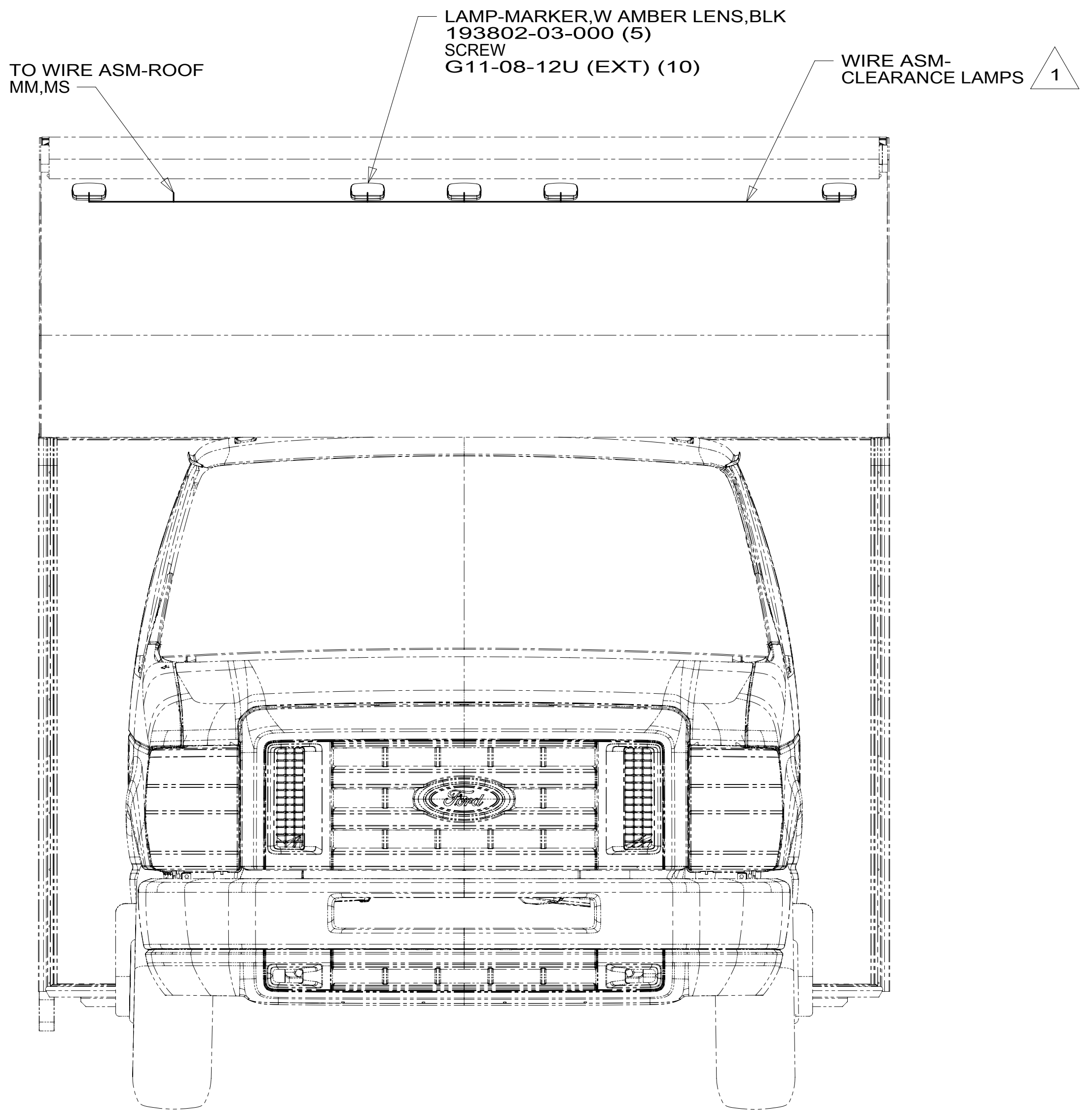

VIEW BA

4 LAMP ASM-STOP/TURN/ TAIL/BACKUP 183787-01-000 SCREW G11-07-12U (6) CONNECTOR 58028-01-000 (4) DETAIL BC

BRACKET-LICENSE 66432-03-000 SCREW G67-10-129 (2) LIGHT-LICENSE 66432-02-000 SCREW G39-08-12T (EXT) (2) CONNECTOR 58028-01-000 (2)

4-PIN HOUSING TO WIRE ASM-CHASSIS

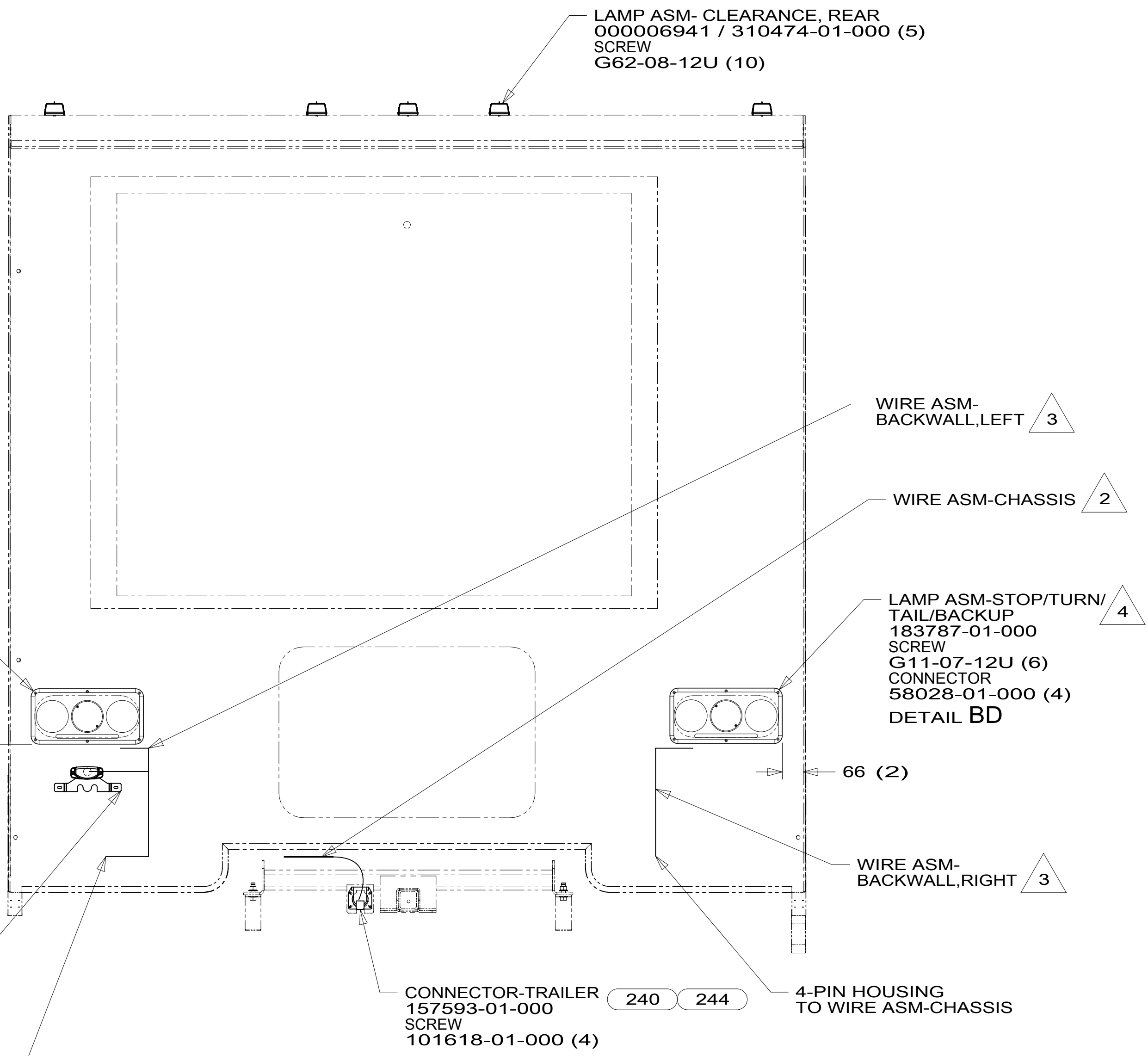

VIEW BE

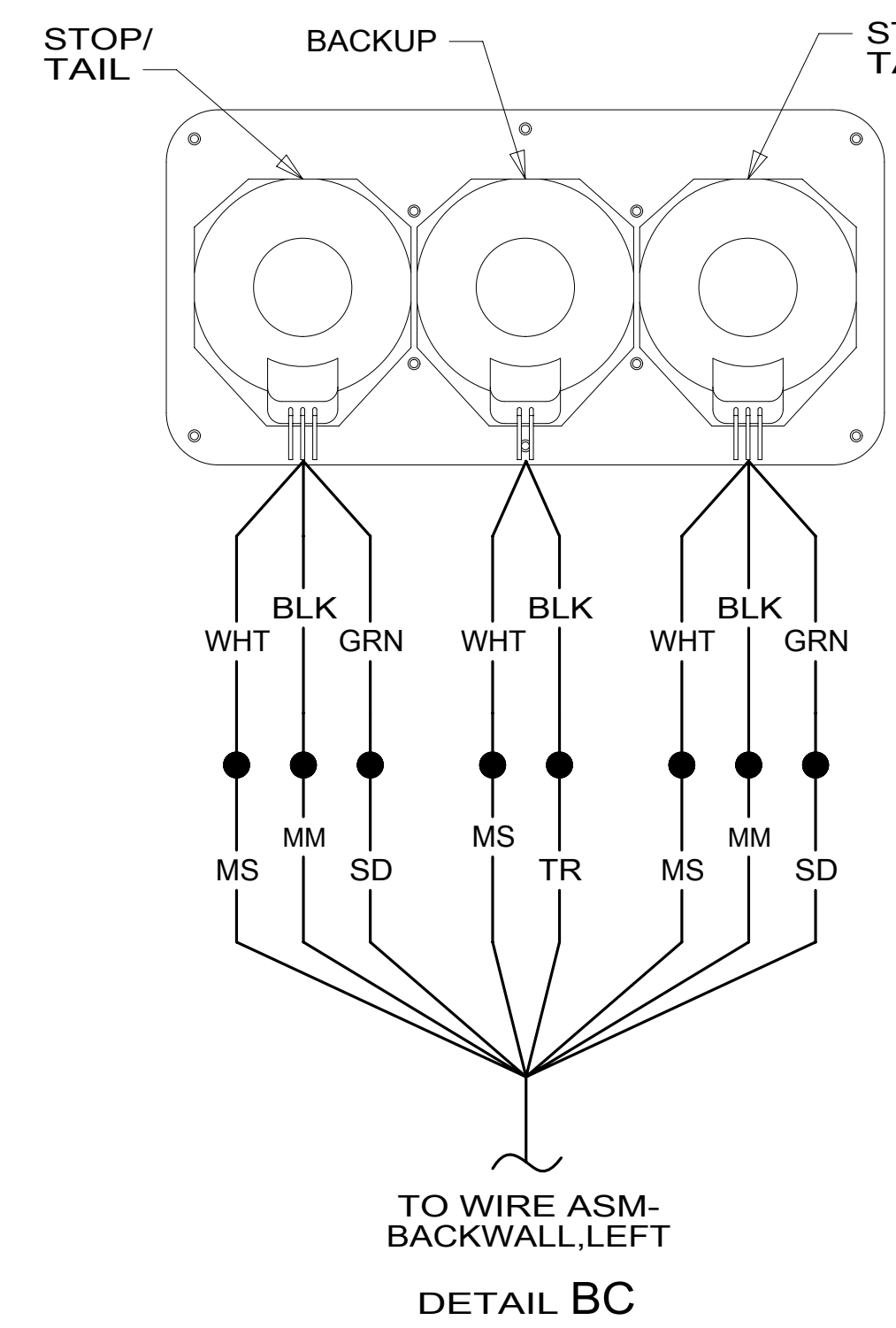

DETAIL BC

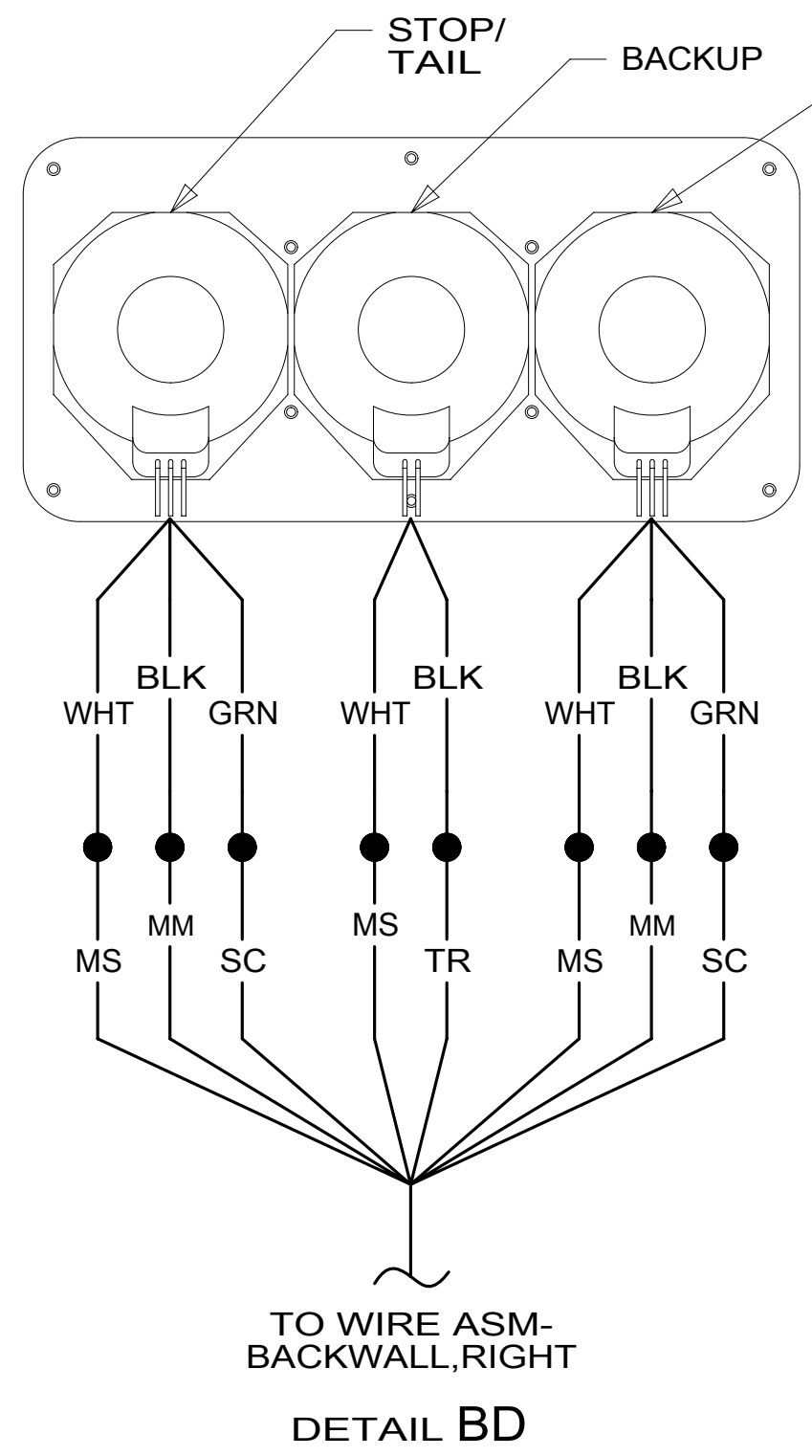

DETAIL BD

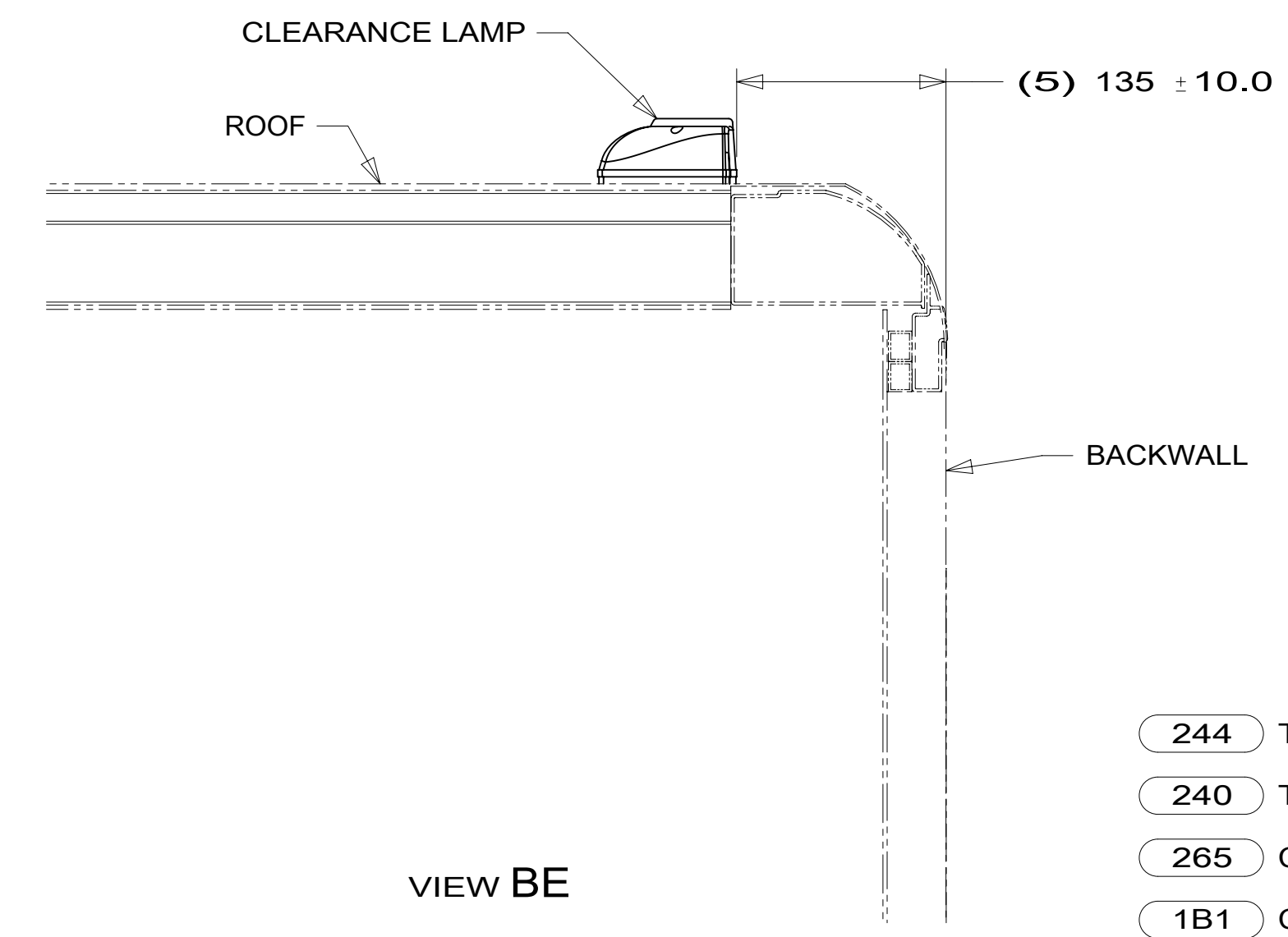

- NOTES:
- 4 TAIL LAMP MUST BE INSTALLED WITH WIRES DOWN.
 - 3 LOCATED IN BACKWALL ASM.
 - 2 SECURE WIRE BELOW COACH WITH CLAMP 10495-01-000 AND SCREW G67-10-12B.
 - 1 LOCATED IN ROOF ASM-FRONT.

- 244 TRAILER HITCH-7500# DRAW BAR
- 240 TRAILER HITCH
- 265 CODES/STANDARDS-CSA/CMVSS
- 1B1 CODES/STANDARDS USA

FOR ELECTRICAL TORQUE SPECIFICATIONS SEE DWG NO. 128783-01-000

FOR ELECTRICAL CALLOUTS SEE DWG NO. 121339-01-000

DESCRIPTION:	1B1 265	
WIRING INSTL-EXTERIOR LAMPS		
SHEET:	ITEM/PART NO.:	REV
2 OF 2	000004945 / 31220301000	