

BATTERY INSTL
00002471 / 312007-01-000

4 PIN HOUSING
TO ELECTRIC STEP

MP,KD
TO STEP DOOR
JAMB SWITCH

BC

MP,JT
TO LP TANK

GROUNDS
DETAIL BB

MAIN 12V DROP
TO WIRE ASM-COACH

110V (BRN) TO COACH

SEAL-TRIM
113452-02-000 (153 MM)

SEAL-TRIM
113452-02-000 (153 MM)

SEAL-TRIM
113452-02-000 (153 MM)

TO FORD SUPPLIED
TAILLAMP CIRCUITS

CABLE ASM-
GENERATOR (GRN)

8 PIN HOUSING
TO GENERATOR

4

7

7

7 PIN HOUSING
TO TRAILER
CONNECTOR

TO GROUND BOLT

8 PIN HOUSING
TO BACKWALL

WIRE ASM-CHASSIS
000016260 / 313096-01-000

DATUM

697

FRONT AXLE

TO BUSS BAR
IN CHASSIS
FUSE BOX

6

TO WIRE ASM-IP,MAIN
(THRU HOLE IN FLOOR)

BATTERY INSTL
(REF)

WIRING TO INVERTER
DATA CABLES
CABLE ASM-FROM FUSE TO INVERTER (ORG)(REF)
CABLE ASM-FROM BATTERY TO INVERTER (BLK)(REF)
CABLE ASM-TEMPERATURE (REF)
CABLE ASM-INVERTER GROUND (REF)

8

WIRING TO SLIDEOUT ROOM
4-PIN HSG
110V (BRN)

2- 2 PIN HSGS, 4 PIN HSG,2- 6 PIN HSGS
TO SLIDEOUT MODULE

GROMMET
023942-02-000
SEAL

CHASSIS ELECTRICAL BOX ASM
191494-06-000

GROMMET
023942-01-000 (6)
SEAL

ROUTE SLIDEOUT MOTOR
WIRES THROUGH HOLE
IN COMPARTMENT

- 8 RUN ALL CABLES THROUGH GROMMET BEFORE SEALING.
- 7 COVER SHARP EDGES WHERE WIRE CROSSES FRAME RAILS.
- 6 SEE WIRING INSTL-FRONT END FOR ADDITIONAL INFORMATION.
- 5 CLAMP 83610-01-000, SCREW G11-10-16B.
- 4 SEE BATTERY INSTL FOR ADDITIONAL INFORMATION.

- 3. WIRE TIE 8343-04-000. FASTEN EVERY 600MM MINIMUM.
- 2. ALL DIMENSIONS ARE FROM DATUM UNLESS OTHERWISE SPECIFIED.
- 1. SECURE CONDUIT 41953, TAB AS REQUIRED, OVER ALL WIRES IN CONTACT WITH SHARP EDGES.

NOTES:

- 16L FORD 22,000#-22.5 AL WHL
- 265 CODES/STANDARDS-CSA/CMVSS
- 1B1 CODES/STANDARDS USA

1B1 265 16L



COPYRIGHT 2016 WINNEBAGO INDUSTRIES, INC.

DSNR:		ALL DIMENSIONS ARE IN MILLIMETERS	
DFFR:		MATERIAL:	
UNSPECIFIED TOLERANCES:		WEIGHT: (LBS)	FIRST USED:
WHOLE DIM (X)	: 3		17 E35F
ONE-PLACE (X.X)	: 1.5		
TWO-PLACE (X.XX)	: 0.50		
ANGLE	: 1°		

REFER TO ES0018 FOR FASTENER TIGHTENING GUIDELINES

WIRING INSTL-CHASSIS

SHEET: 1 OF 2 ITEM/PART NO: 000002439 / 31200401000 REF: 1 13-Dec-2016

FOR ELECTRICAL TORQUE SPECIFICATIONS SEE DWG NO. 128783-01-000

FOR ELECTRICAL CALLOUTS SEE DWG NO. 121339-01-000

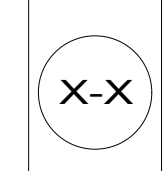

8 7 6 5 4 3 2 1

D

D

C

C

B

B

A

A

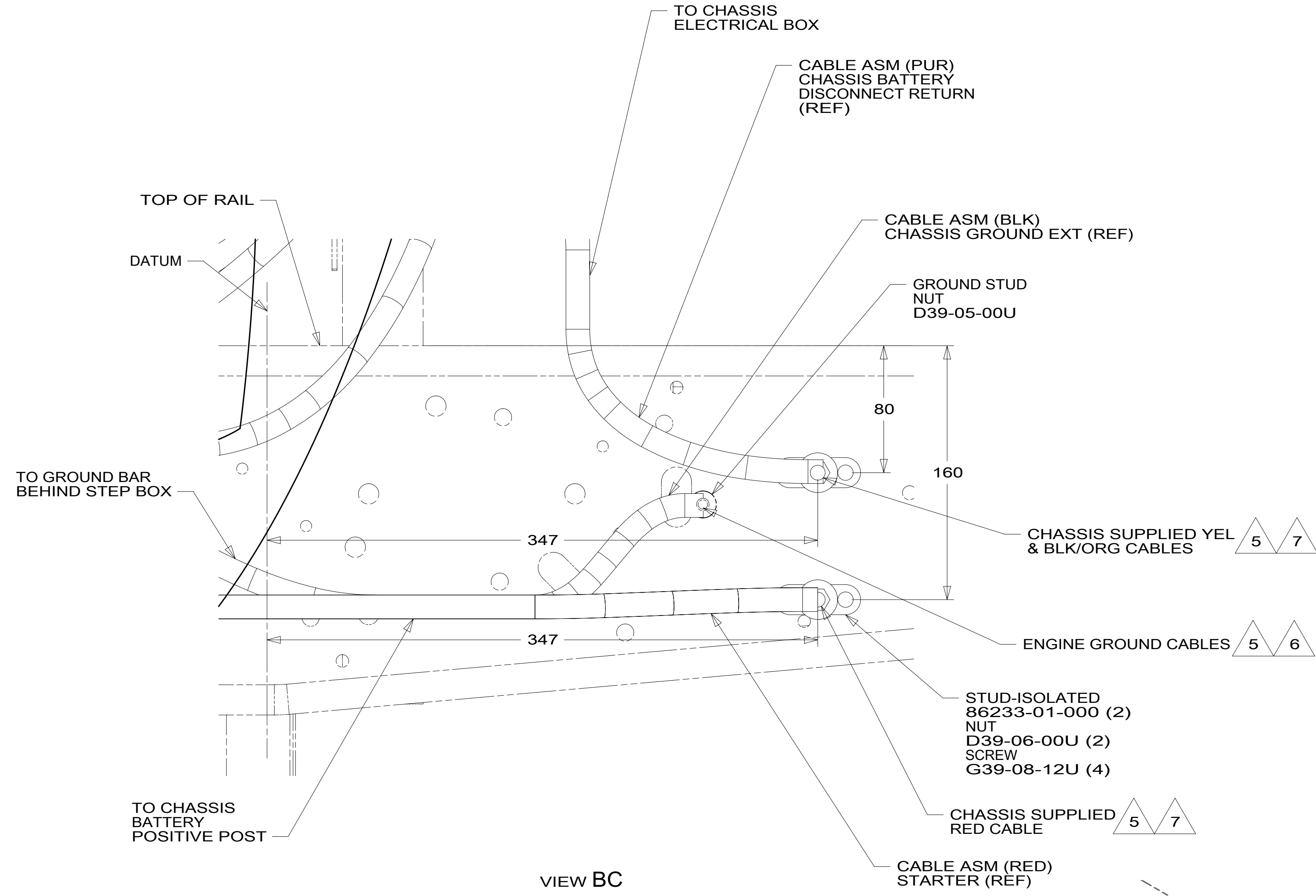

VIEW BC

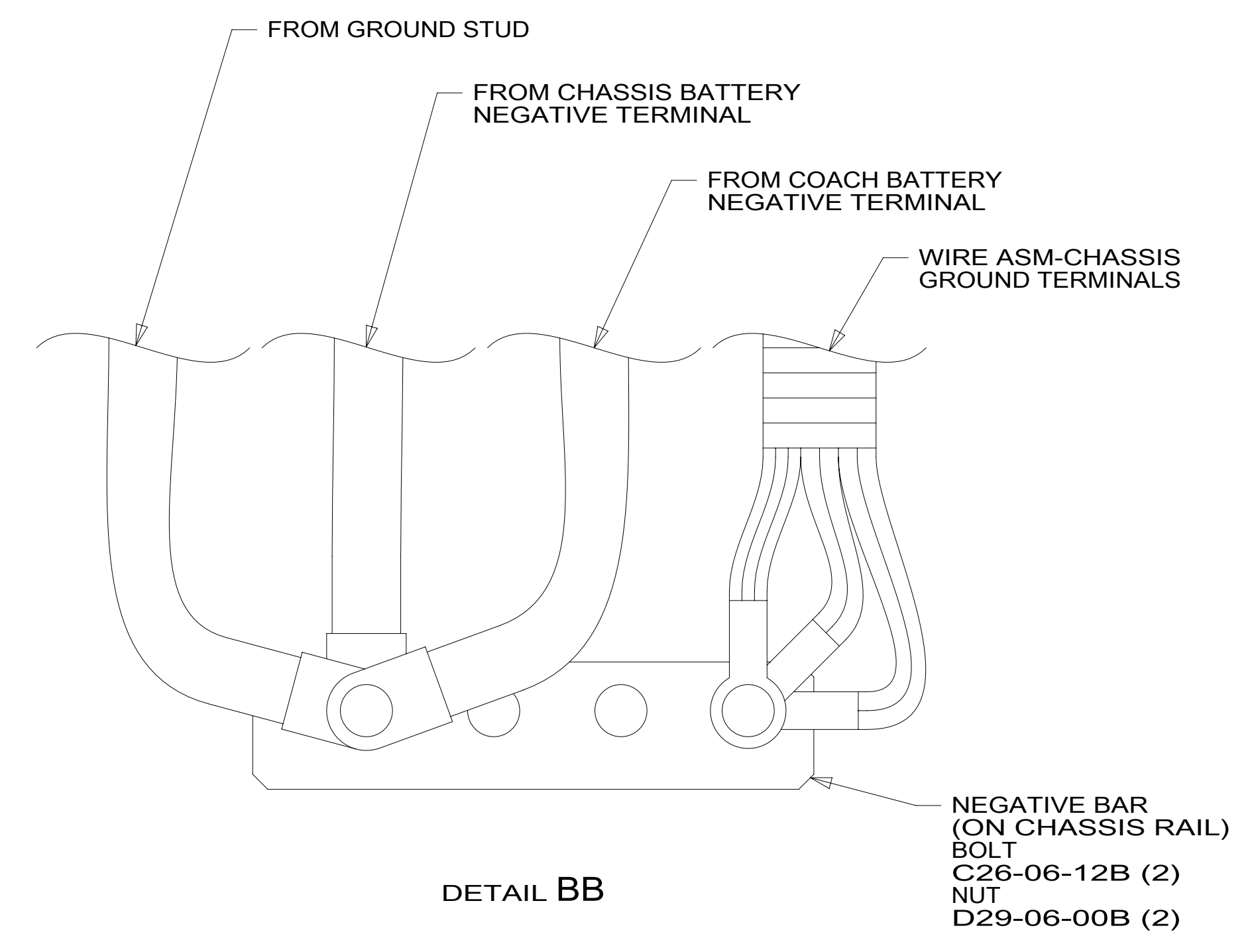

DETAIL BB

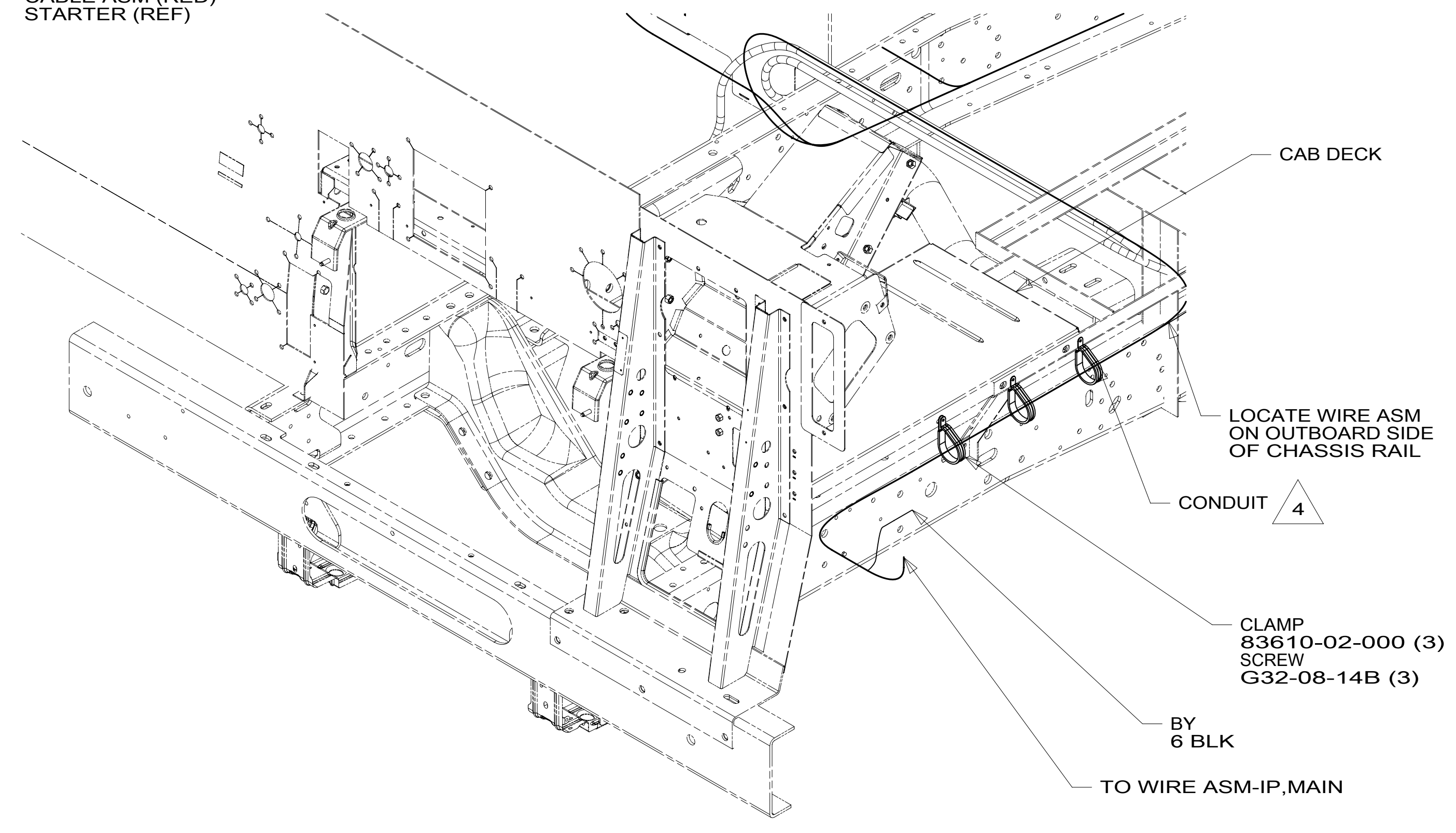

VIEW BA

- NOTES:
- 7 CUT CHASSIS SUPPLIED POSITIVE BATTERY CABLE 150 MM FROM BATTERY TERMINAL END, DISCARD TERMINAL END AND SEPARATE WIRES. ADD TERMINAL 8348-01-000 AND HEAT SHRINK 176567-04-000 TO RED CABLE (CHASSIS STARTER) AND COMBINE YELLOW (CHASSIS POWER DISTRIBUTION) AND BLACK/ORANGE (CHASSIS ALTERNATOR) WIRES TOGETHER AND ADD TERMINAL 8348-01-000 AND HEAT SHRINK 176567-02-000. COIL EXCESS CABLE ALONG FRAME RAIL JUST BEHIND RADIATOR AND TIE UP WITH TIE-WIRE 8343-04-000.
 - 6 CUT CHASSIS SUPPLIED BATTERY CABLE 700 MM FROM BATTERY TERMINAL AND ADD TERMINAL 8348-01-000 TO CUT END.
 - 5 SUPPLIED WITH CHASSIS.
 - 4 COVER WITH CONDUIT 41953-10-000 AND 41953-11-000 AS REQUIRED.
 - 3. CONNECT CABLES TO COACH SIDE OF BATTERY DISCONNECT WHEN BATTERY DISCONNECT IS USED.
 - 2. ALL GROUND WIRE TO BE COVERED WITH TUBING 8041-02-000.
 - 1. CUT OFF EXCESS END OF WIRE TIE.

FOR ELECTRICAL TORQUE SPECIFICATIONS SEE DWG NO. 128783-01-000

FOR ELECTRICAL CALLOUTS SEE DWG NO. 121339-01-000

- 16L FORD 22,000#-22.5 AL WHL
- 265 CODES/STANDARDS-CSA/CMVSS
- 1B1 CODES/STANDARDS USA

DESCRIPTION:	1B1 265 16L	
WIRING INSTL-CHASSIS		
SHEET:	ITEM/PART NO:	REV
2 OF 2	000002439 / 31200401000	

8 7 6 5 4 3 2 1 13-Dec-2016