

DRAWING NO.	MODEL	SHEET
189171-01	D30A	1,2,3,4,5
189171-02	D33C	1,2,3,4,5
189171-03	D35G	1,2,3,4,5
189171-04	D36Z	1,2,3,4,6

RELEASE	REV/DATE	DWG NO	189171
REV ZONE	REVISION RECORD	DATE	DTR-ORIG

		D30A	D33C	D35G	D36Z
SLIDEOUT WIRE #1		136151-02-020	136151-03-026	136151-03-021	136151-04-047
SLIDEOUT WIRE #2		136151-06-020	136151-13-022		136151-02-047
SLIDEOUT WIRE #3		136151-12-020	136151-06-022		136151-05-047
SLIDEOUT WIRE #4		136151-13-020	136151-20-022		136151-06-047
SLIDEOUT WIRE #5			136151-12-022		136151-15-047
SLIDEOUT WIRE #6			136151-03-022		136151-03-012
SLIDEOUT WIRE #7			136151-10-022		
THROW IN WIRE #1	1B1	136131-12-218	136131-02-013	136131-03-015	136131-04-041
	265	136134-12-218	136134-02-013	136134-03-015	136134-04-041
THROW IN WIRE #2	1B1		136131-12-033	136131-12-024	136131-04-040
	265		136134-12-033	136134-12-024	136134-04-040
THROW IN WIRE #3	1B1	136131-04-011	136131-04-008	136131-04-011	136131-04-112
	265	136134-04-011	136134-04-008	136134-04-011	136134-04-112
THROW IN WIRE #4	1B1	136131-12-011	136131-12-008	136131-12-011	136131-02-025
	265	136134-12-011	136134-12-008	136134-12-011	136134-02-025
THROW IN WIRE #5	1B1	136131-02-078	136131-13-020	136131-15-025	136131-02-018
	265	136134-02-078	136134-13-020	136134-15-025	136134-02-018
THROW IN WIRE #6	1B1	136131-06-026	136131-12-263	136131-12-162	136131-05-016
	265	136134-06-026	136134-12-263	136134-12-162	136134-05-016
THROW IN WIRE #7	1B1	136131-12-038	136131-03-052	136131-03-055	136131-06-018
	265	136134-12-038	136134-03-052	136134-03-055	136134-06-018
THROW IN WIRE #8	1B1	136131-13-023	136131-03-049	136131-12-030	136131-15-049
	265	136134-13-023	136134-03-049	136134-12-030	136134-15-049

		D30A	D33C	D35G	D36Z
THROW IN WIRE #9	1B1		136131-20-044	136131-03-030	136131-03-014
	265		136134-20-044	136134-03-030	136134-03-014
THROW IN WIRE #10	1B1		136131-10-037		136131-03-037
	265		136134-10-037		136134-03-037
THROW IN WIRE #11	1B1		136131-03-015		
	265		136134-03-015		
THROW IN WIRE #12	1B1		136131-03-022		136131-02-050
	265		136136-03-022		136134-02-050
THROW IN WIRE #13	1B1		136131-03-006		
	265		136136-03-006		

- SEE DETAIL DD FOR CONNECTOR INSTALLATION.
- SEE DETAIL DC FOR CONNECTOR INSTALLATION.
- SEE DETAIL DB FOR CONNECTOR INSTALLATION.
- SEE DETAIL DA FOR CONNECTOR INSTALLATION.

3. SEE WIRING INSTL-BODY, 12V FOR ADDITIONAL INFORMATION.
2. SECURE WIRES TO BACKSIDE OF LOAD CENTER WITH WIRE TIE 116673-01-000.
1. ALL GROUNDS WIRES TO BE COVERED WITH TUBING 8041-02-000.

NOTES:

- INVERTER-DC/AC, 1000 WATT
- BED-QUEEN SIDEWALL
- AIR SLEEP SYSTEM-QUEEN SIZE
- BED-KING OFF SIDEWALL
- AIR SLEEP SYSTEM- KING SIZE
- EXT ENTERTAIN CTR W/TV & CD
- CODES/STANDARDS-CSA/CMVSS
- CODES/STANDARDS USA



DTR	ORIG. DATE
CHKR	ALL DIMENSIONS ARE IN MILLIMETERS
P.E.	
M.E.	FIRST USED
DSNR	15 D-SERIES
UNSPECIFIED TOLERANCES ARE:	
WHOLE DIM (X)	: 3
ONE-PLACE (X.X)	: 1.5
TWO-PLACE (X.XX)	: 0.50
ANGLE	: 1°
THIRD ANGLE PROJECTION	
DO NOT SCALE DRAWING	REFER TO ES0018 FOR FASTENER TIGHTENING GUIDELINES
TITLE: LOAD CENTER/ATS ASM	
SHEET 1 OF 6	PART NO 189171 REV
REF:	1 08-Oct-2015

FOR ELECTRICAL TORQUE SPECIFICATIONS SEE DWG NO. 128783-01-000

FOR ELECTRICAL CALLOUTS SEE DWG NO. 121339-01-000

189171

		D30A	D33C	D35G	D36Z
RED	1B1	136135-07-063	136135-07-061	136135-07-052	136135-07-060
	265	136136-07-063	136136-07-061	136136-07-052	136136-07-060
YEL	1B1	136131-05-032	136131-05-016	136131-05-012	136131-05-075
	265	136134-05-032	136134-05-016	136134-05-012	136134-05-075
YEL-2	1B1	136131-13-045	136131-13-083	136131-13-062	
	265	136134-13-045	136134-13-083	136134-13-062	
BLK	1B1	136131-06-045	136131-06-083	136131-06-020	136131-06-075
	265	136134-06-045	136134-06-083	136134-06-020	136134-06-075
BRN	1B1	136131-03-138	136131-03-096	136131-03-030	136131-03-120
	265	136134-03-138	136134-03-096	136134-03-030	136134-03-120
BLU	1B1	136131-02-045	136131-02-076	136131-02-150	136131-02-087
	265	136134-02-045	136134-02-076	136134-02-150	136134-02-087
GRN	1B1	136135-08-063	136135-08-058	136135-08-052	136135-08-060
	265	136136-08-063	136136-08-058	136136-08-052	136136-08-060

		D30A	D33C	D35G	D36Z
PUR	1B1	136131-04-045	136131-04-068	136131-04-060	136131-04-093
	265	136134-04-045	136134-04-068	136134-04-060	136134-04-093
WHT	1B1	136135-09-033	136135-09-040	136135-09-043	136135-09-054
	265	136136-09-033	136136-09-040	136136-09-043	136136-09-054
MAIN	1B1	136139-01-033	136139-01-066	136139-01-030	176841-01-048
	265	136140-01-033	136140-01-066	136140-01-030	176841-01-048
GROUND MAIN		136145-01-031	136145-01-016	136145-01-015	136145-01-039
GROUND ATS		136145-01-022	136145-01-052	136145-01-015	136145-01-022
GRY	1B1			136131-15-020	136131-15-077
	265			136134-15-020	136134-15-077
GLD	1B1		136131-10-083	136131-10-061	
	265		136134-10-083	136134-10-061	
GLD-2	1B1		136131-20-083	136131-20-061	
	265		136134-20-083	136134-20-061	
INVERTER CHARGER MAIN	1B1				136137-01-012
	265				136138-01-012
INVERTER CHARGER SUB MAIN	1B1				136137-01-012
	265				136138-01-012

- SEE DETAIL DA FOR CONNECTOR INSTALLATION.
- SEE WIRING INSTL-BODY, 12V FOR ADDITIONAL INFORMATION.
 - ATTACH WIRES TO BACKSIDE OF LOAD CENTER, USE EXISTING HOLES AND TIE-WIRE 116673-01-000.
 - REMOVE 400MM FROM OUTER JACKET ON ALL WIRES ENTERING LOAD CENTER AND TRIM INDIVIDUAL CONDUCTORS AS REQUIRED TO MAKE INTERNAL CONNECTIONS
 - ALL 110V STRANDED WIRE W/O TERMINALS TO BE STRIPPED 10MM AND SOLDER DIPPED.
 - ALL WIRES TO BE CLAMPED WITHIN 200MM OF ATS.
 - GROUND WIRES ARE NOT SHOWN FOR CLARITY.
 - ALL GROUND WIRES TO BE COVERED WITH TUBING 8041-02-000.

CODES/STANDARDS-CSA/CMVSS
 CODES/STANDARDS USA

FIRST USED

15 D-SERIES

DO NOT SCALE DRAWING

TITLE: **LOAD CENTER/ATS ASM**

SHEET 2 PART NO **189171** REV

FOR ELECTRICAL TORQUE SPECIFICATIONS SEE DWG NO. 128783-01-000

FOR ELECTRICAL CALLOUTS SEE DWG NO. 121339-01-000

189171

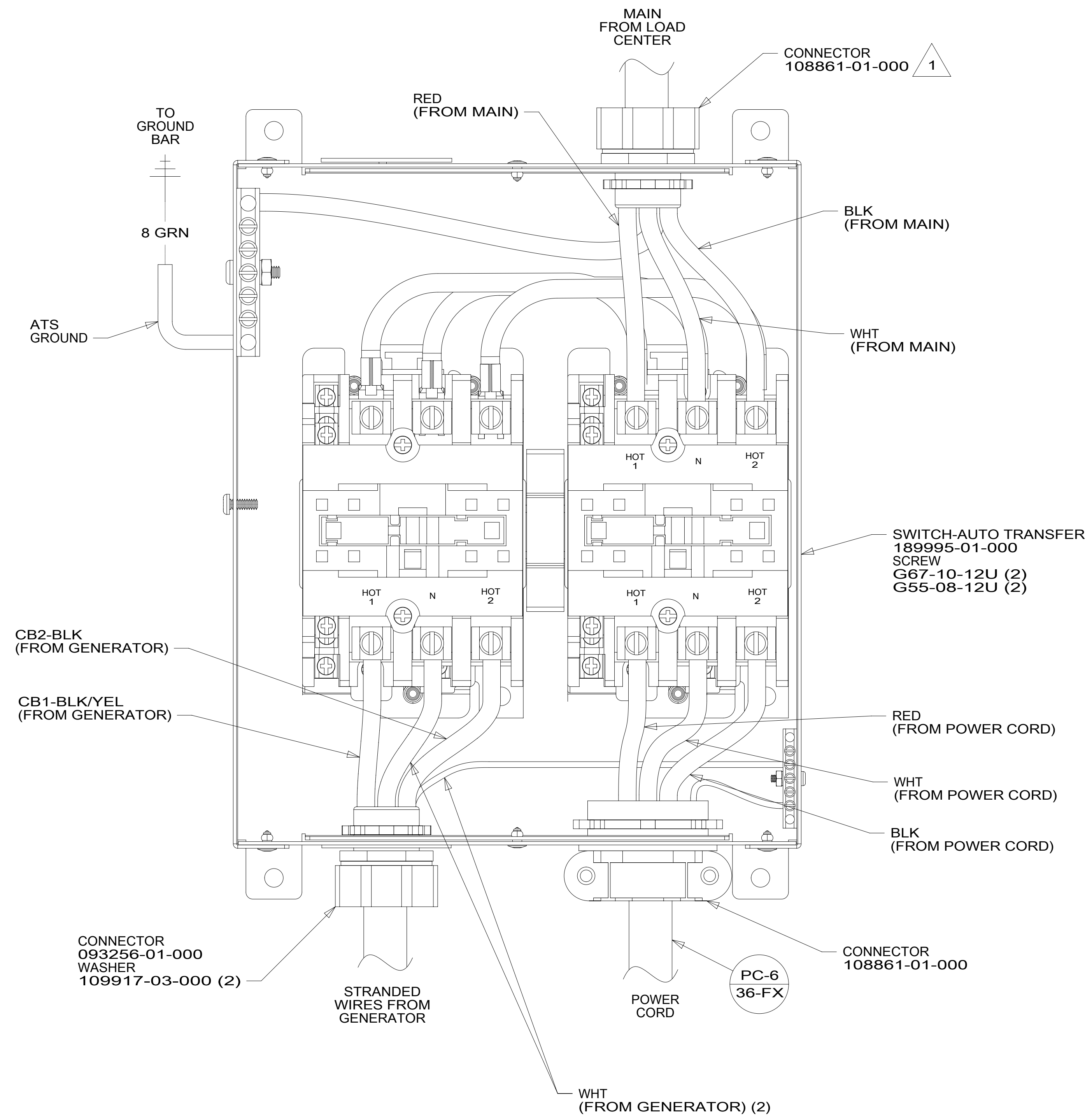

NOTES:
 1 USED ONLY ON D30A, D33C, AND D35G.

FOR ELECTRICAL TORQUE SPECIFICATIONS SEE DWG NO. 128783-01-000

FOR ELECTRICAL CALLOUTS SEE DWG NO. 121339-01-000

265 CODES/STANDARDS-CSA/CMVSS
 1B1 CODES/STANDARDS USA
 1B1 265

FIRST USED		
15 D-SERIES		
DO NOT SCALE DRAWING		
TITLE: LOAD CENTER/ATS ASM		
SHEET 3	PART NO 189171	REV

189171

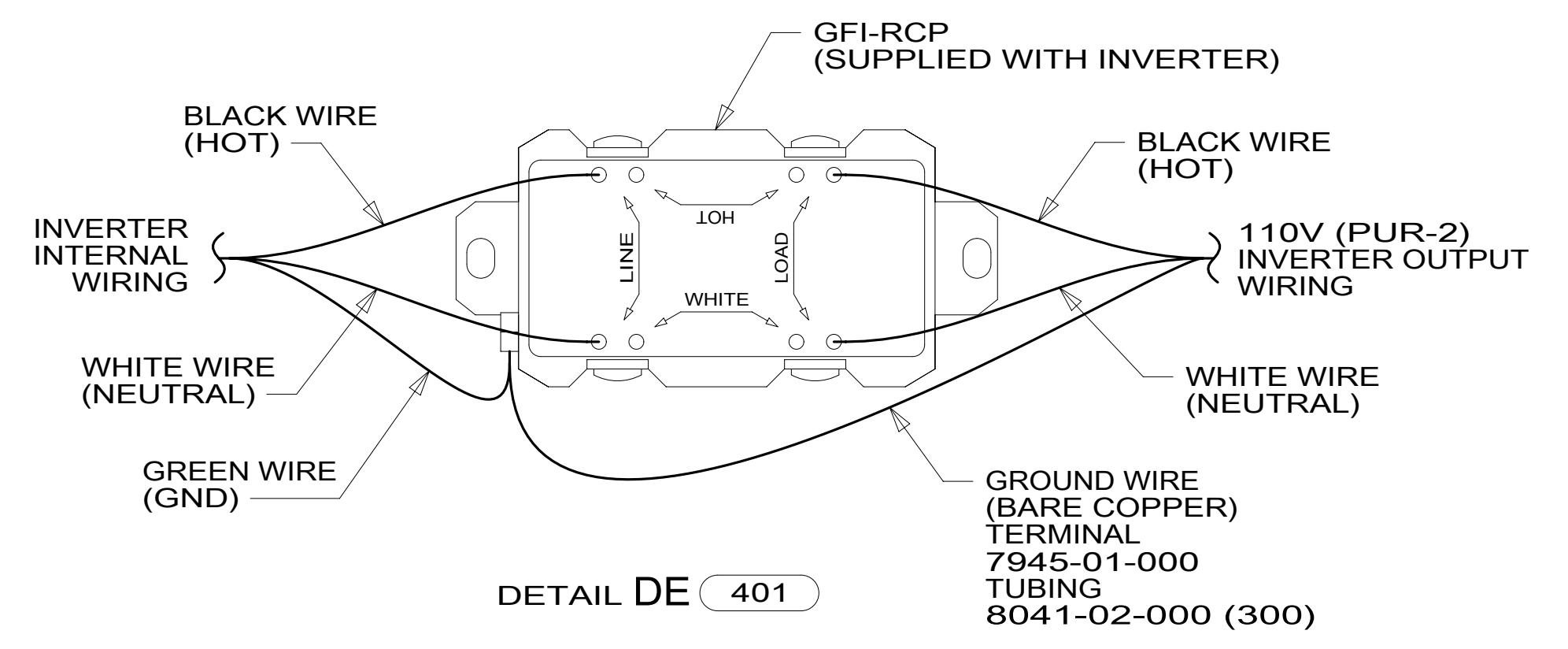
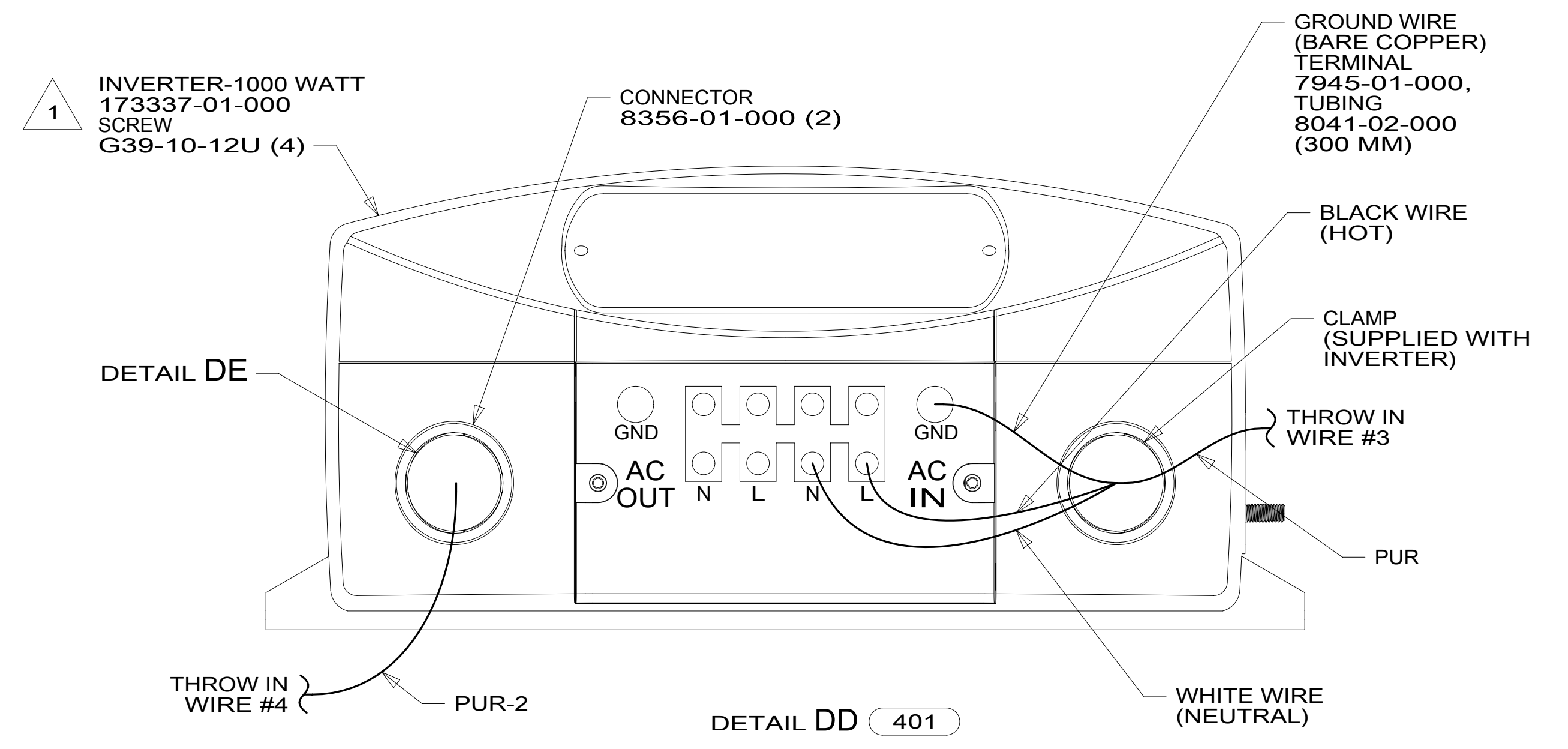
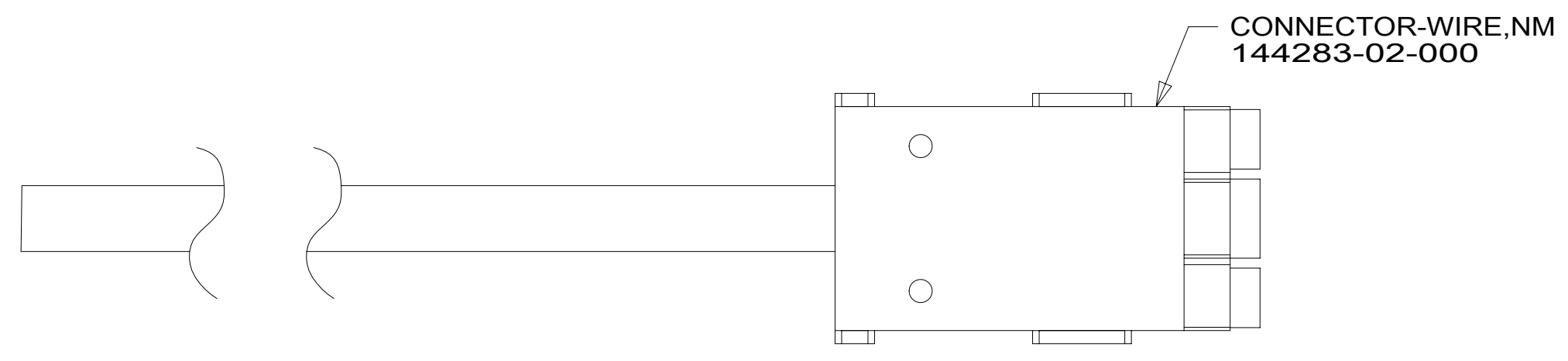

NOTES:

1 INVERTER SUPPLIED WITH REMOTE PANEL.
SEND PANEL TO MANUFACTURING LINE.

FOR ELECTRICAL TORQUE SPECIFICATIONS SEE DWG NO. 128783-01-000

FOR ELECTRICAL CALLOUTS SEE DWG NO. 121339-01-000

- 401 INVERTER-DC/AC, 1000 WATT
- 265 CODES/STANDARDS-CSA/CMVSS
- 1B1 CODES/STANDARDS USA

FIRST USED	15 D-SERIES
TITLE:	DO NOT SCALE DRAWING
SHEET 4	LOAD CENTER/ATS ASM
PART NO.	189171
REV	08-Oct-2015

189171

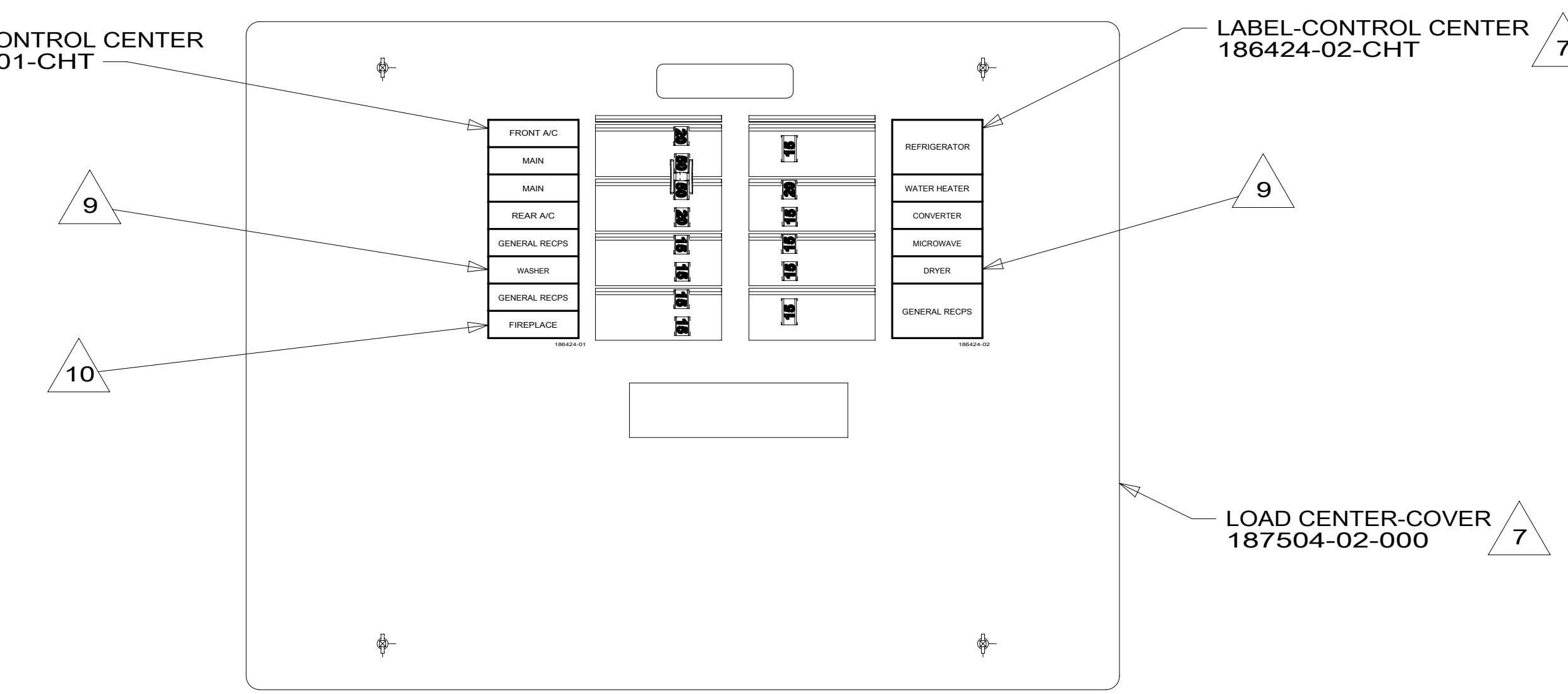
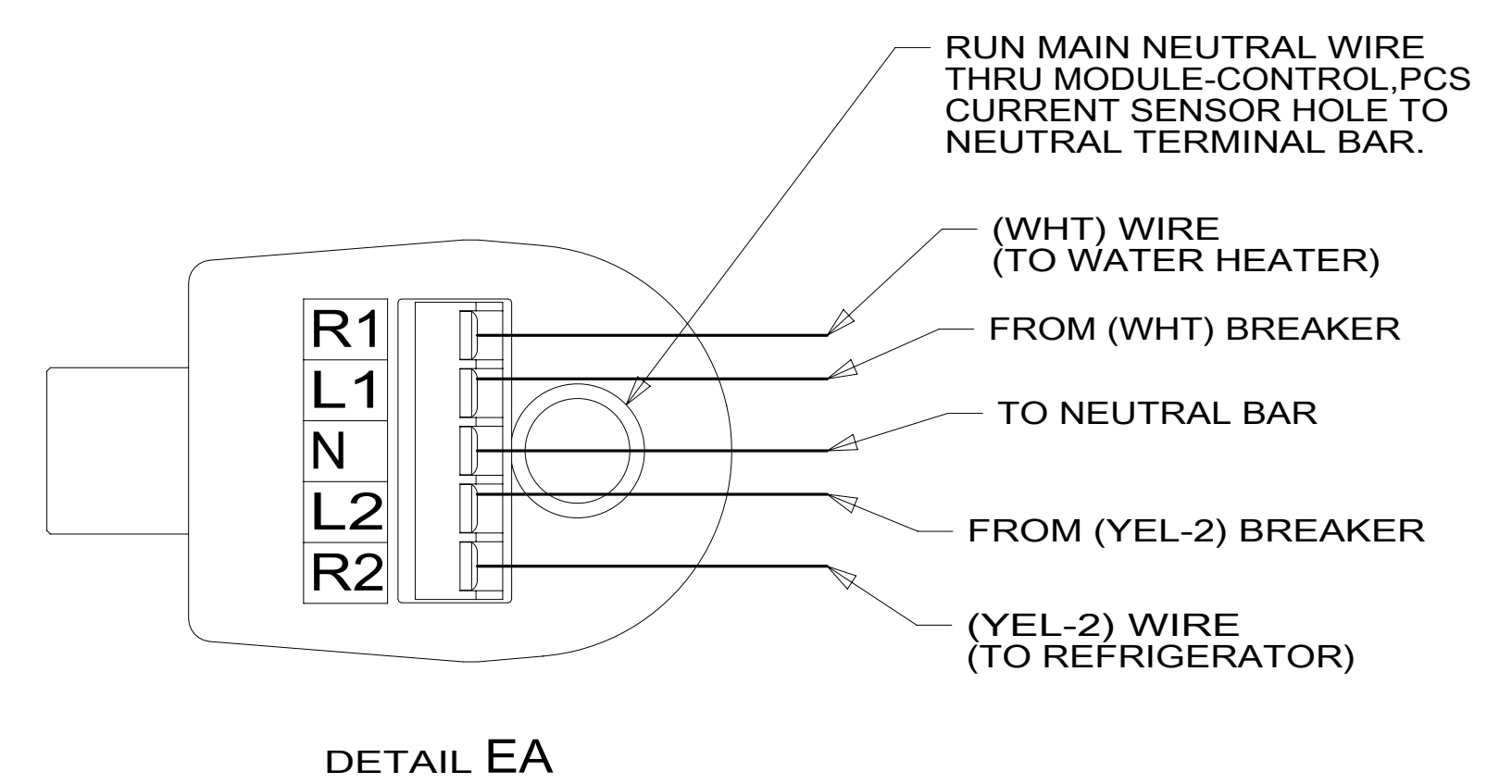
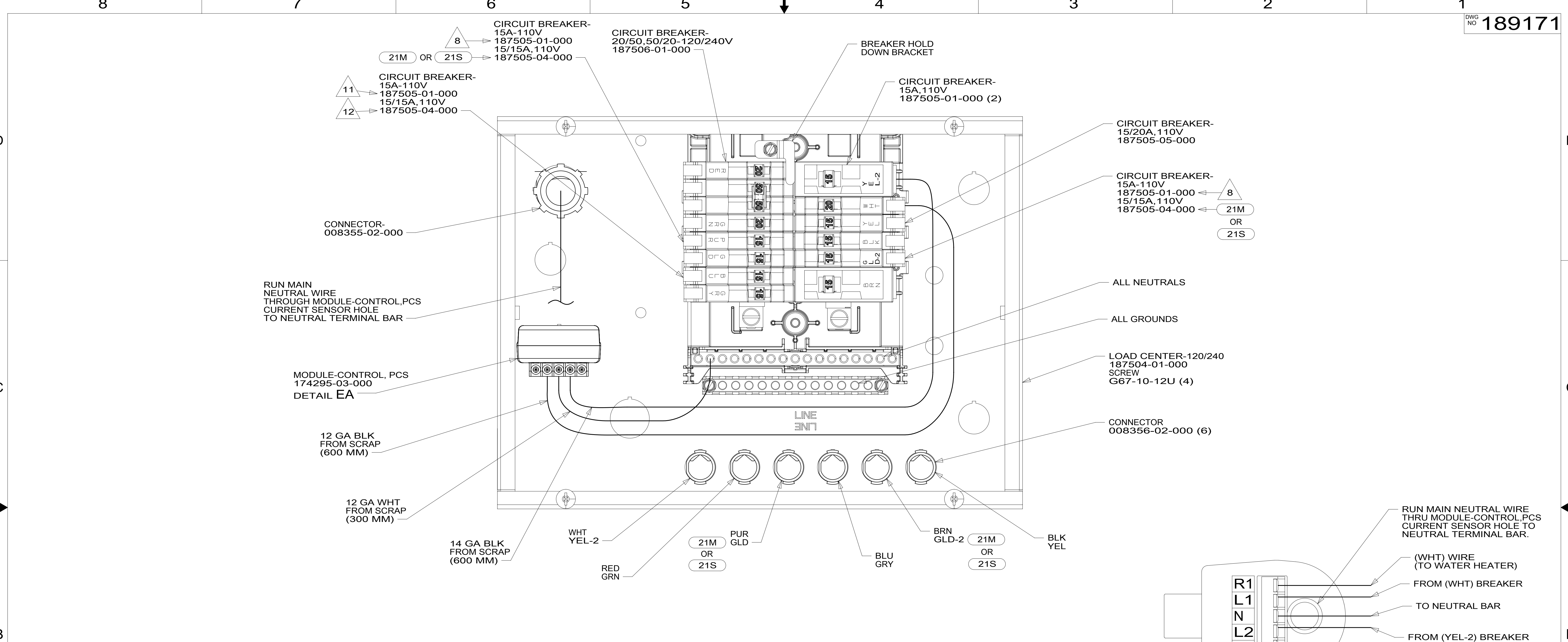

- 12 USED WITH D35G.
- 11 USED WITH D30A & D33C.
- 10 BLACKEN OUT 'FIREPLACE' WITH BLACK MARKER ON UNITS W/O 14C
- 9 BLACKEN OUT 'WASHER' AND 'DRYER' WITH BLACK MARKER ON UNITS W/O 21M OR 21S
- 8 NOT USED WITH 21M OR 21S
- 7 INSTALLED BY ASSEMBLY LINE.

6. REMOVE 400MM FROM OUTER JACKET ON ALL WIRES ENTERING LOAD CENTER AND TRIM INDIVIDUAL CONDUCTORS AS REQUIRED TO MAKE INTERNAL CONNECTIONS
5. ATTACH WIRES TO BACKSIDE OF LOAD CENTER, USE EXISTING HOLES AND TIE-WIRE 116673-01-000.
4. ALL 110V STRANDED WIRE W/O TERMINALS TO BE STRIPPED 10MM AND SOLDER DIPPED.
3. ALL WIRES TO BE CLAMPED WITHIN 200MM OF ATS.
2. GROUND WIRES ARE NOT SHOWN FOR CLARITY.
1. ALL GROUND WIRES TO BE COVERED WITH TUBING 8041-02-000.

NOTES:

FOR ELECTRICAL TORQUE SPECIFICATIONS SEE DWG NO. 128783-01-000

FOR ELECTRICAL CALLOUTS SEE DWG NO. 121339-01-000

- 21S WASHER & DRYER-PAIR
- 21M WASHER/DRYER PREP
- 14C FIREPLACE-ELECTRIC
- 265 CODES/STANDARDS-CSA/CMVSS
- 1B1 CODES/STANDARDS USA

1B1 265

FIRST USED

15 D-SERIES

DO NOT SCALE DRAWING

TITLE: **LOAD CENTER/ATS ASM**

SHEET 5 PART NO **189171** REV

1 08-Oct-2015

189171

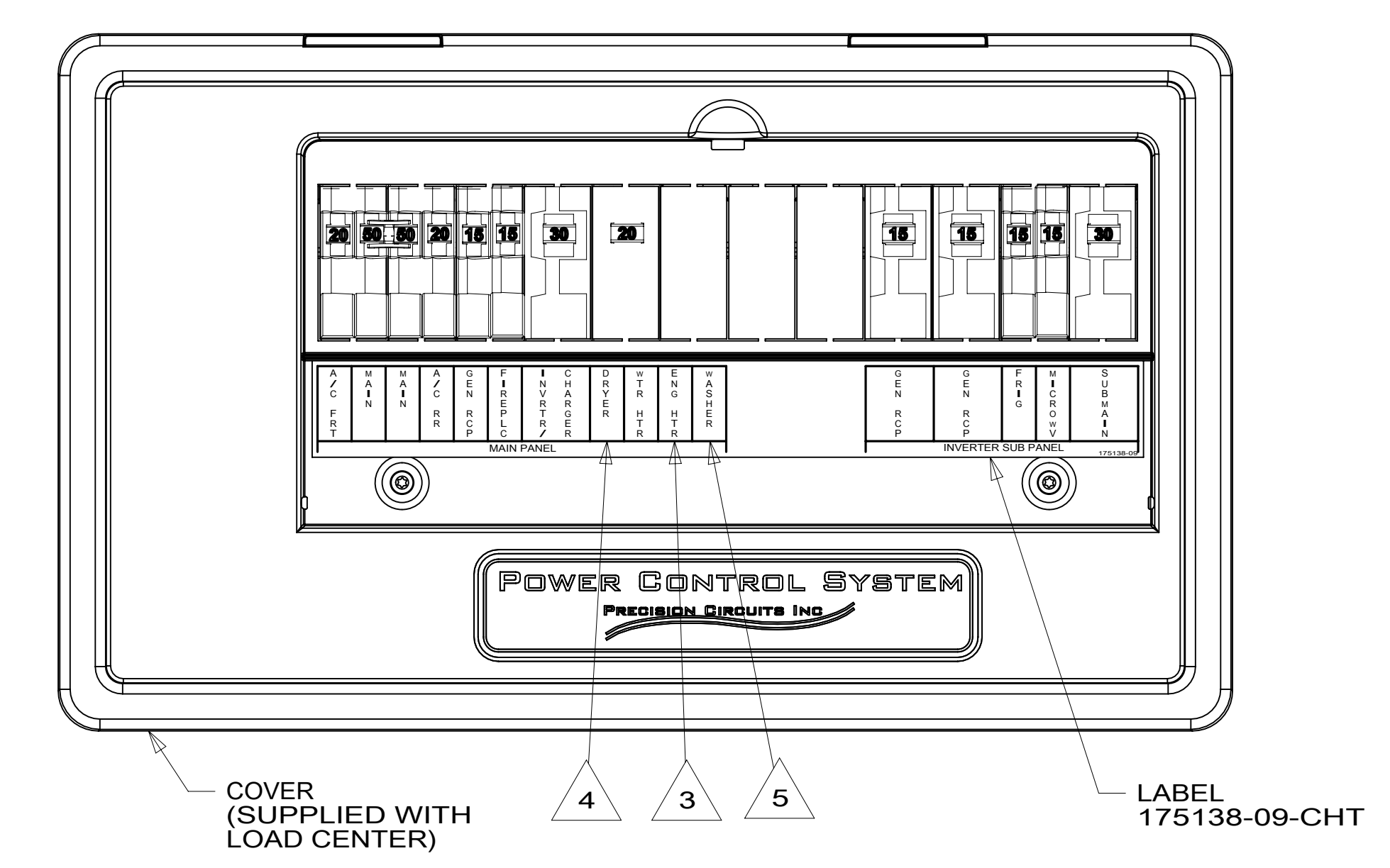
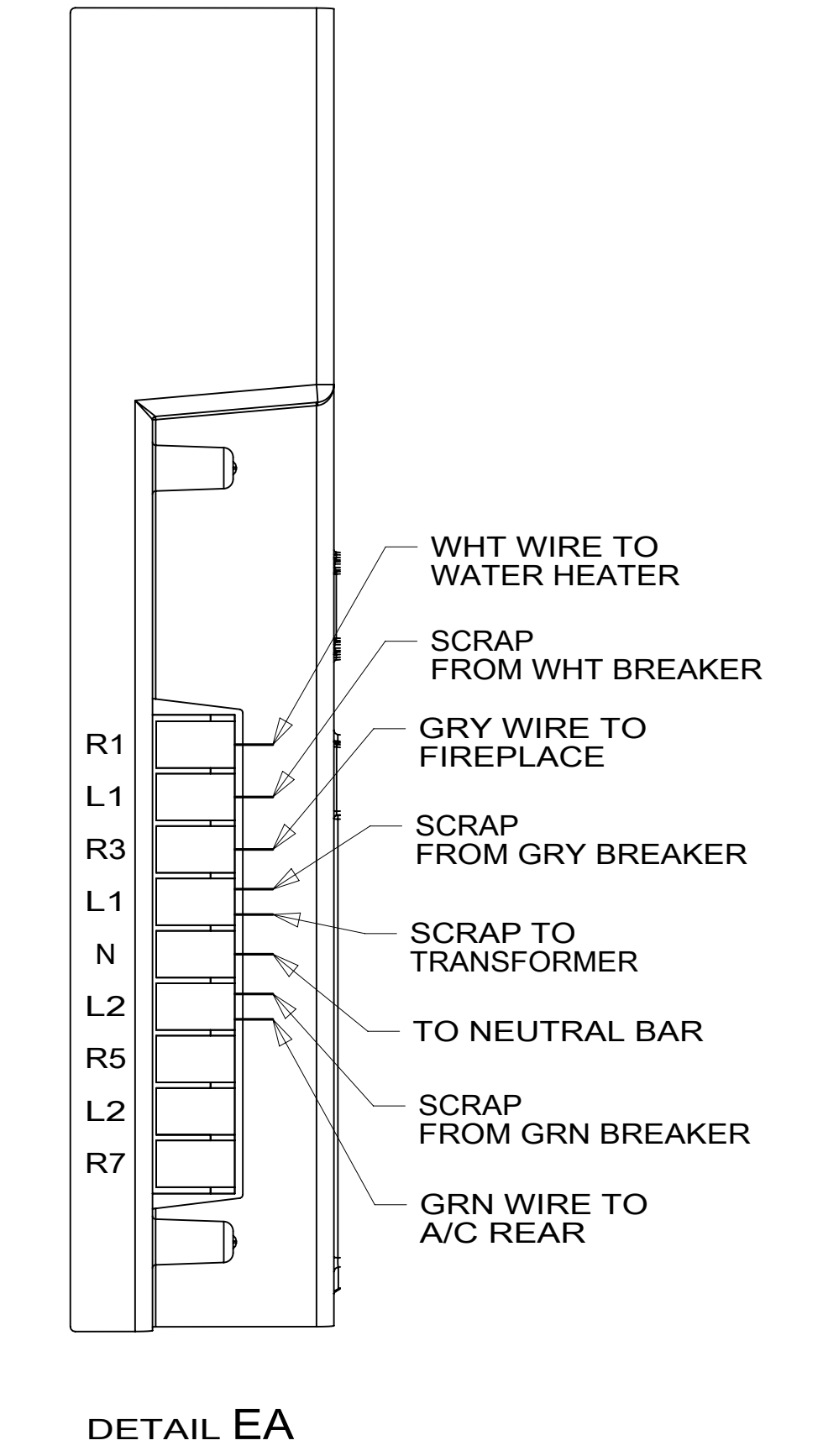
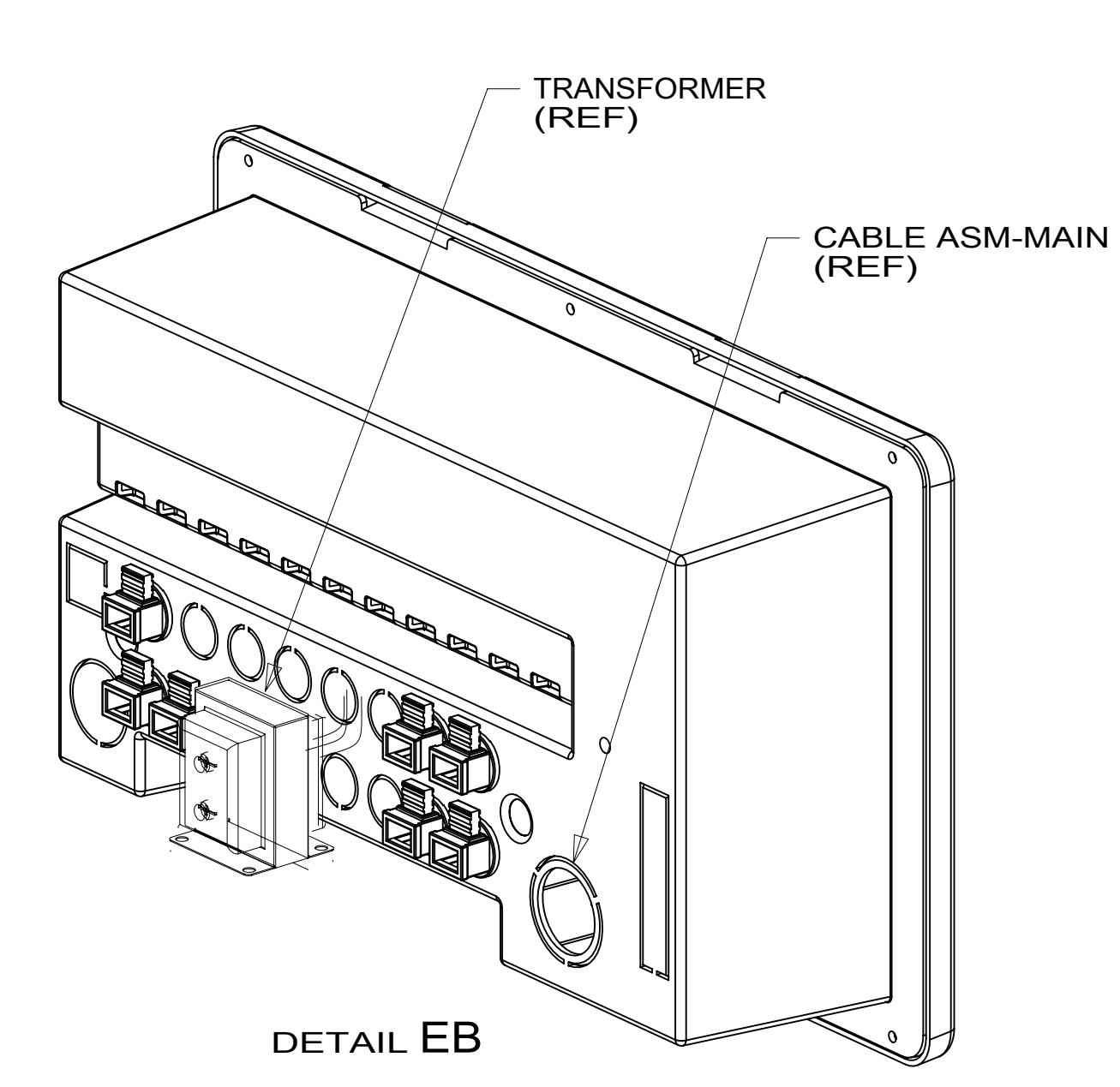
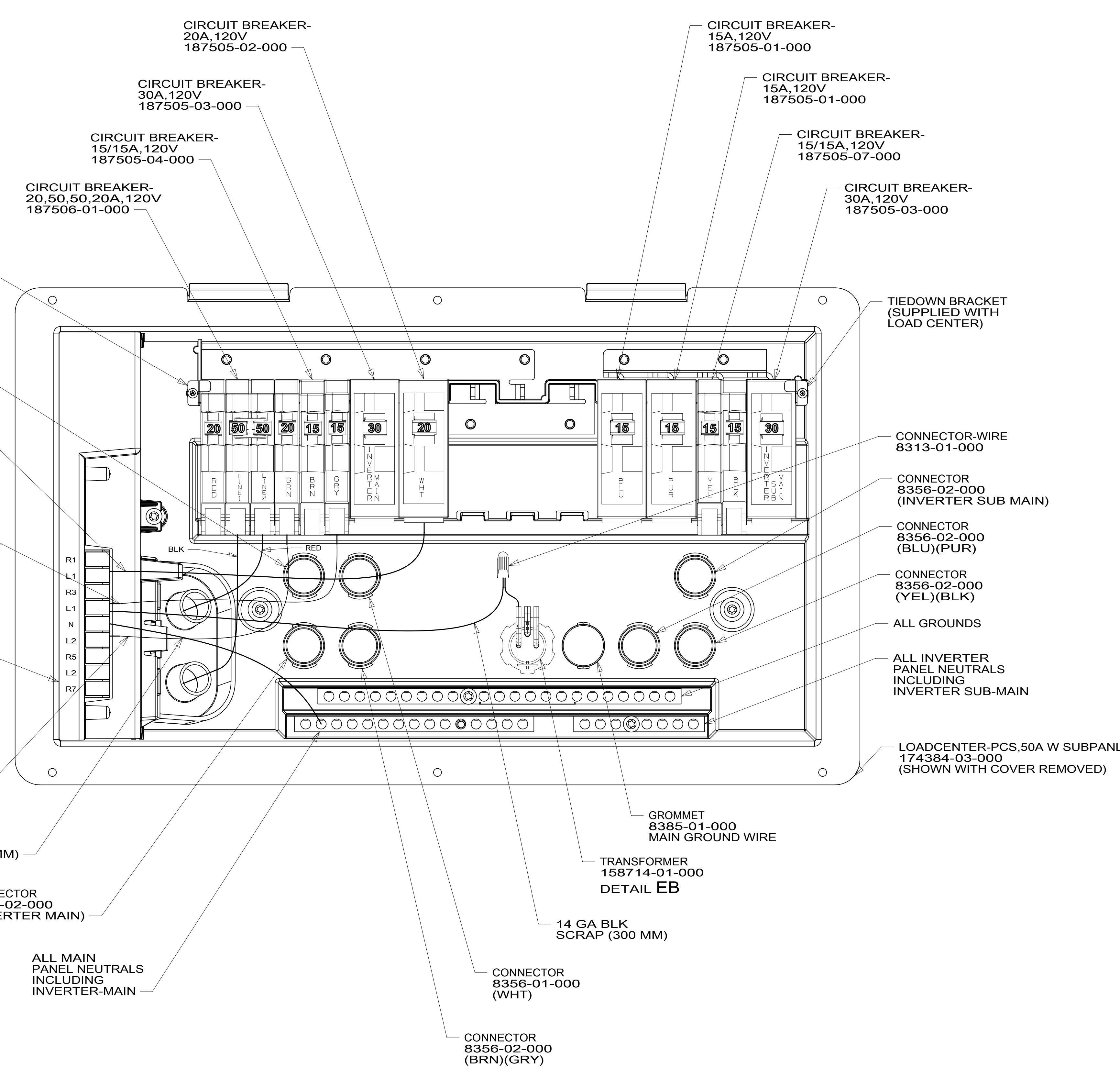

- 5 BLACKEN OUT WASHER.
- 4 BLACKEN OUT DRYER.
- 3 BLACKEN OUT ENG HTR.

2. REMOVE 400MM FROM OUTER JACKET ON ALL WIRES ENTERING LOAD CENTER AND TRIM INDIVIDUAL CONDUCTORS AS REQUIRED TO MAKE INTERNAL CONNECTIONS
1. ALL GROUND WIRES TO BE COVERED WITH TUBING 8041-02-000.

NOTES:

265 CODES/STANDARDS-CSA/CMVSS
 1B1 CODES/STANDARDS USA

1B1	265
FIRST USED	
15 D-SERIES	
DO NOT SCALE DRAWING	
TITLE: LOAD CENTER/ATS ASM	
SHEET 6	PART NO 189171 REV
1 08-Oct-2015	

FOR ELECTRICAL TORQUE SPECIFICATIONS SEE DWG NO. 128783-01-000

X-X FOR ELECTRICAL CALLOUTS SEE DWG NO. 121339-01-000

189171