

DRAWING NO.	MODEL
187612-01	R42QD/QL
187612-02	R42HD/HL
187612-03	R42GD

RELEASE A	REV/DATE	DWG NO. 187612
REV ZONE	REVISION RECORD	DATE DFR-ORIG

		R42QD/QL	R42HD/HL	R42GD
RED	1B1	136135-07-071	136135-07-086	136135-07-067
	265	136136-07-071	136136-07-086	136136-07-067
MAIN	1B1	174031-01-062	174031-01-056	174031-01-072
	265	174031-01-062	174031-01-056	174031-01-072
GRN	1B1	136135-08-071	136135-08-086	136135-08-067
	265	136136-08-071	136136-08-086	136136-08-067
LT BLU	1B1	136135-21-071	136135-21-086	136135-21-067
	265	136136-21-071	136136-21-086	136136-21-067
INVERTER CHARGER MAIN	1B1	136137-01-087	136137-01-088	136137-01-100
	265	136138-01-087	136138-01-088	136138-01-100
YEL	1B1	136131-05-131 ¹	136131-05-124	136131-05-138 ¹
	265	136134-05-131 ¹	136134-05-124	136134-05-138 ¹
GLD	1B1	136131-10-075	136131-10-071	136131-10-023 ¹
	265	136134-10-075	136134-10-071	136134-10-023 ¹
GLD-2	1B1	136131-20-060	136131-20-071	136131-20-023 ¹
	265	136134-20-060	136134-20-071	136134-20-023 ¹
WHT	1B1	136135-09-067	136135-09-066	136135-09-082
	265	136136-09-067	136136-09-066	136136-09-082
RANGE	1B1	136135-01-056 ⁴	136135-01-066 ²	136135-01-097 ²
	265	136136-01-056 ⁴	136136-01-066 ²	136136-01-097 ²
AWNING	1B1	136131-01-072	136131-01-086	136131-01-067
	265	136134-01-072	136134-01-086	136134-01-067

		R42QD/QL	R42HD/HL	R42GD
INVERTER CHARGER SUB MAIN	1B1	136137-01-087	136137-01-096	136137-01-114
	265	136138-01-087	136138-01-096	136138-01-114
BLU	1B1	136131-02-224 ¹	136131-02-160 ¹	136131-02-220 ¹
	265	136134-02-224 ¹	136134-02-160 ¹	136134-02-220 ¹
BRN	1B1	136131-03-098 ¹	136131-03-100 ¹	136131-03-110 ¹
	265	136134-03-098 ¹	136134-03-100 ¹	136134-03-110 ¹
PUR	1B1	136131-04-095 ¹	136131-04-094	136131-04-206 ¹
	265	136134-04-095 ¹	136134-04-094	136134-04-206 ¹
ORG	1B1	136131-16-160	136131-16-161	136131-16-186
	265	136134-16-160	136134-16-161	136134-16-186
BLK	1B1	136131-06-056 ¹	136131-06-065 ¹	136131-06-097 ¹
	265	136134-06-056 ¹	136134-06-065 ¹	136134-06-097 ¹
SIL	1B1	136131-11-056 ¹	136131-11-065 ¹	136131-11-097 ¹
	265	136134-11-056 ¹	136134-11-065 ¹	136134-11-097 ¹
GRY	1B1	136131-15-092 ¹	136131-15-100 ¹	136131-15-072
	265	136134-15-092 ¹	136134-15-100 ¹	136134-15-072
GROUND MAIN		136145-01-065	136145-01-060	136145-01-071
GROUND ATS		136145-01-020	136145-01-030	136145-01-025
GROUND INVERTER		136145-04-006	136145-04-006	136145-04-006
CABLE ASM GEN		174031-03-095	174031-03-095	174031-03-095
TAILGATE	1B1	136135-01-045	136135-01-061	136135-01-075
	265	136136-01-045	136136-01-061	136136-01-075

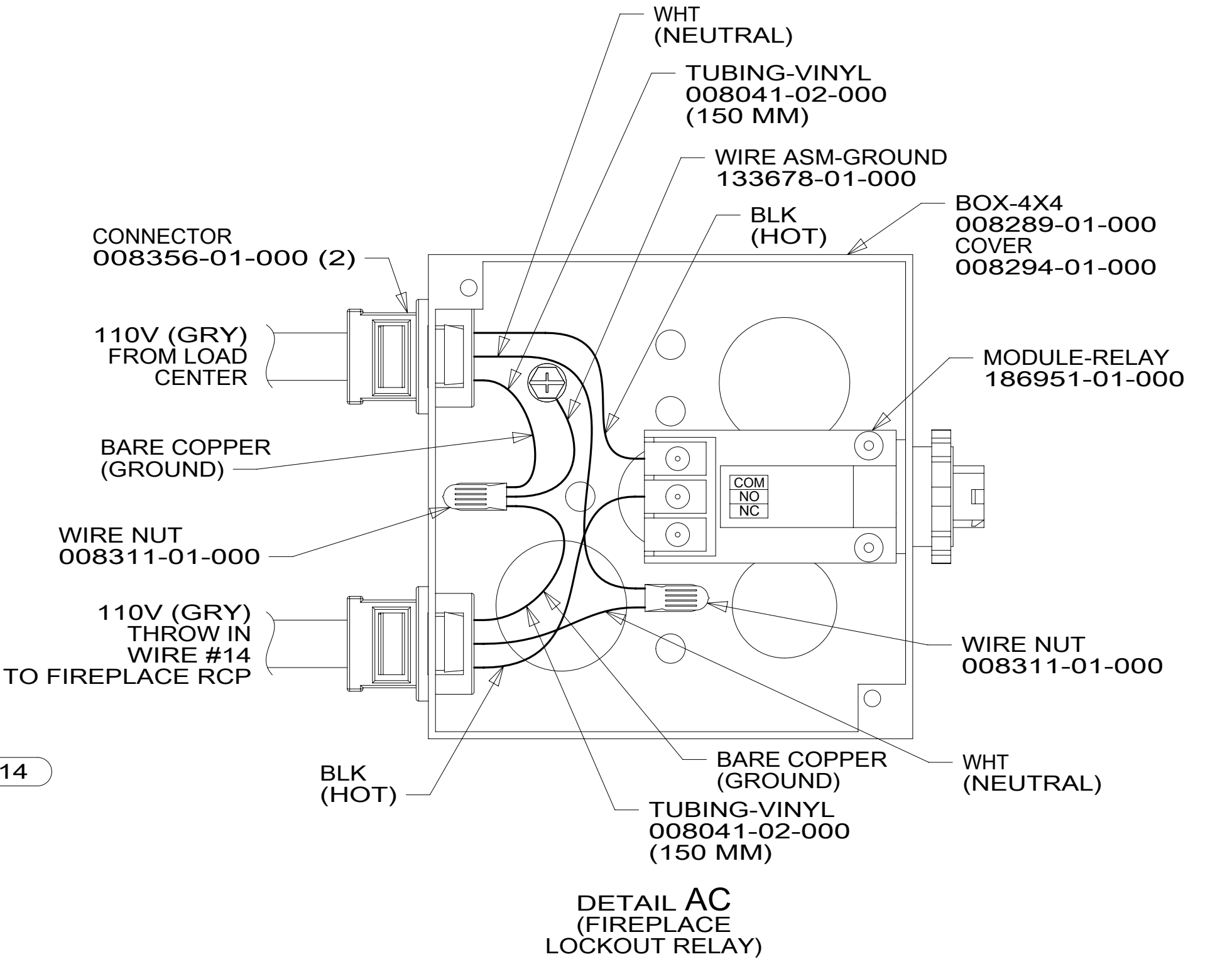

- 67G GEN-10KW_ONAN QUIET DIESEL
- 9PC TAILGATE PACKAGE
- 63H AWNING (2) PATIO, ARMLESS
- 214 DISHWASHER DRAWER STYLE
- 265 CODES/STANDARDS-CSA/CMVSS
- 1B1 CODES/STANDARDS USA

- NOTES:
- ⁴ SEE DETAIL AB
 - ³ CONNECT WIRES, WHT TO WHT, BLK TO BLK, GROUNDS TO GROUNDS, KEEPING CIRCUITS SEPERATED.
 - ² SEE DETAIL AA FOR CONNECTOR INSTALLATION.
 - ¹ SEE DETAIL BA FOR CONNECTOR INSTALLATION.

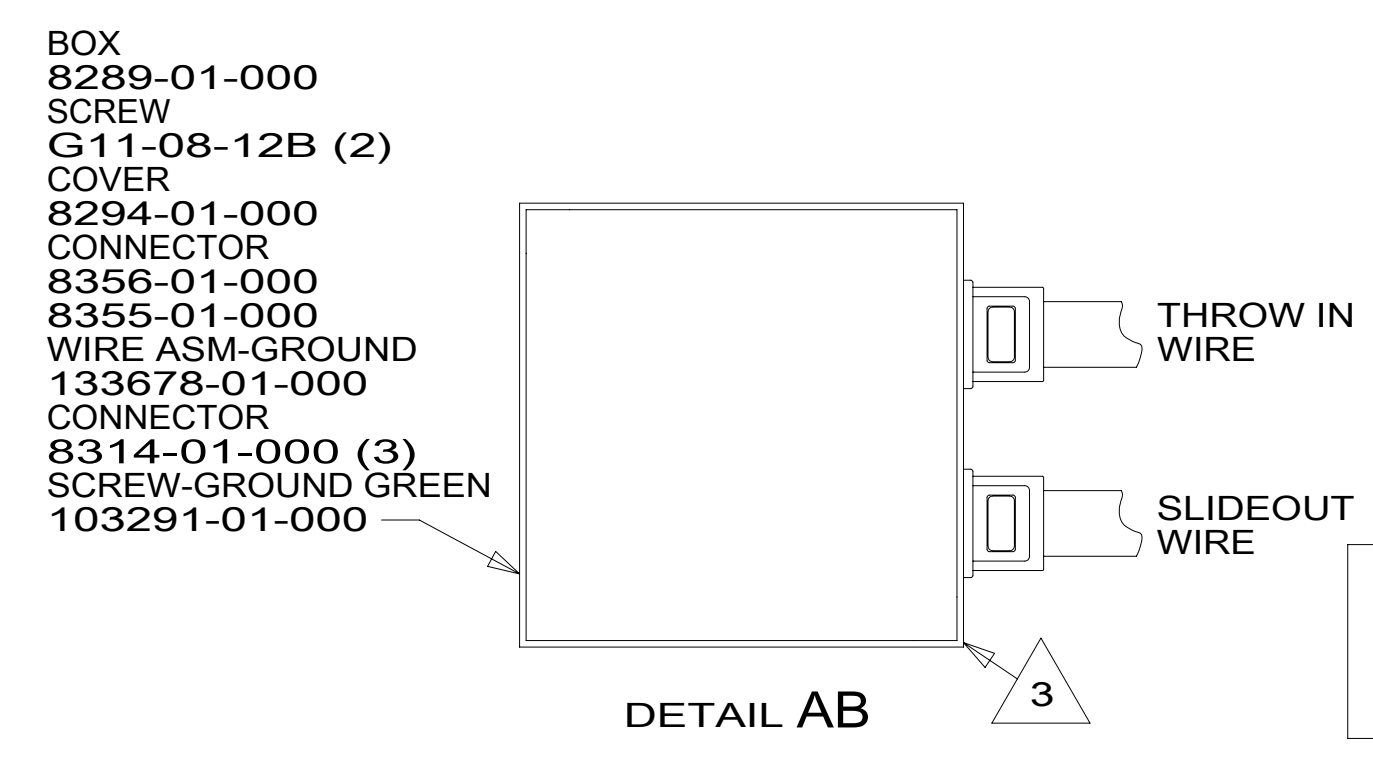
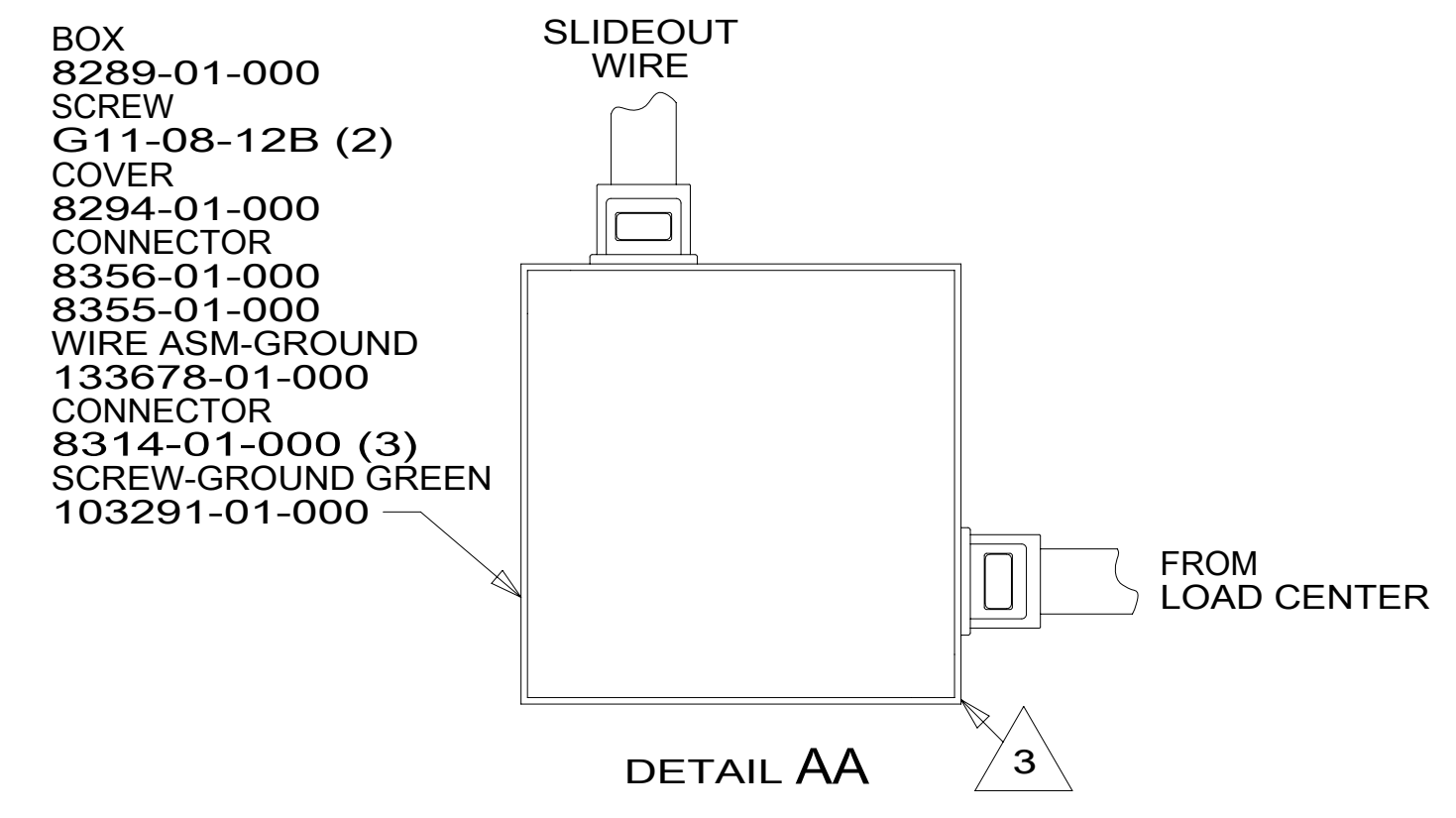

FOR ELECTRICAL TORQUE SPECIFICATIONS SEE DWG NO. 128783-01-000

FOR ELECTRICAL CALLOUTS SEE DWG NO. 121339-01-000

WINNEBAGO

COPYRIGHT 2014 WINNEBAGO INDUSTRIES, INC.

DFTR	ORIG. DATE
CHKR	ALL DIMENSIONS ARE IN MILLIMETERS
P.E.	
M.E.	FIRST USED
DSNR	15 R-SERIES

UNSPECIFIED TOLERANCES ARE:

WHOLE DIM (X)	: 3
ONE-PLACE (X.X)	: 1.5
TWO-PLACE (X.XX)	: 0.50
ANGLE	: 1'

THIRD ANGLE PROJECTION

DO NOT SCALE DRAWING REFER TO ES0018 FOR FASTENER TIGHTENING GUIDELINES

TITLE: **LOAD CENTER/ATS ASM**

SHEET 1 OF 3 PART NO. 187612 REV

REF: 1 12-Nov-2015

187612

	R42QD/QL	R42HD/HL	R42GD
SLIDEOUT WIRE #1	136151-03-025 ⁴	136151-06-040 ²	136151-02-030 ²
SLIDEOUT WIRE #2	136151-04-025 ⁴	136151-02-040 ²	136151-11-030 ² (214)
SLIDEOUT WIRE #3	136151-05-025 ⁴	136151-11-040 ²	136151-06-030 ²
SLIDEOUT WIRE #4	136151-15-025 ⁴	136152-01-044 ³	136152-01-035 ³
SLIDEOUT WIRE #5	136152-01-042 ³	136151-04-022 ²	136151-04-042 ²
SLIDEOUT WIRE #6	136151-04-022 ²	136151-04-014 ⁴	136151-03-042 ²
SLIDEOUT WIRE #7	136151-02-070 ²	136151-03-040 ⁴	136151-10-014 ²
SLIDEOUT WIRE #8	136151-06-070 ²	136151-02-040 ⁴	136151-20-014 ²
SLIDEOUT WIRE #9	136151-11-070 ² (214)	136151-15-040 ⁴	136151-04-028 ²
SLIDEOUT WIRE #10			136151-02-050 ⁴
SLIDEOUT WIRE #11			136151-03-050 ⁴
SLIDEOUT WIRE #12			136151-05-050 ²
THROW IN WIRE #1	1B1 136131-03-052	136131-02-041 ¹	136131-04-062 ¹
	265 136134-03-052	136134-02-041 ¹	136134-04-062 ¹
THROW IN WIRE #2	1B1 136131-03-032 ¹	136135-01-017 ³	136131-20-035 ¹
	265 136134-03-032 ¹	136136-01-017 ³	136134-20-035 ¹
THROW IN WIRE #3	1B1 136135-01-017 ³	136131-04-044 ¹	136131-04-025 ¹
	265 136136-01-017 ³	136134-04-044 ¹	136134-04-025 ¹

	R42QD/QL	R42HD/HL	R42GD
THROW IN WIRE #4	1B1 136131-04-030	136131-04-040 ¹	136131-02-032 ¹
	265 136134-04-030	136134-04-040 ¹	136134-02-032 ¹
THROW IN WIRE #5	1B1 136131-04-055 ¹	136131-11-020 ¹	136131-02-008 ¹
	265 136134-04-055 ¹	136134-11-020 ¹	136134-02-008 ¹
THROW IN WIRE #6	1B1 136131-04-070 ¹	136131-03-039 ¹	136135-01-003 ³
	265 136134-04-070 ¹	136134-03-039 ¹	136136-01-003 ³
THROW IN WIRE #7	1B1 136131-02-006	136131-03-210	136131-02-050 ¹
	265 136134-02-006	136134-03-210	136134-02-050 ¹
THROW IN WIRE #8	1B1 136131-02-049 ¹	136131-02-070 ¹	136131-11-008 ¹ (214)
	265 136134-02-049 ¹	136134-02-070 ¹	136134-11-008 ¹ (214)
THROW IN WIRE #9	1B1 136131-11-025 ¹ (214)	136131-02-045 (9PC)	136131-03-122 ¹
	265 136134-11-025 ¹ (214)	136134-02-045 (9PC)	136134-03-122 ¹
THROW IN WIRE #10	1B1 136131-15-008	136131-02-070 (9PC)	136131-03-013 ¹
	265 136134-15-008	136134-02-070 (9PC)	136134-03-013 ¹
THROW IN WIRE #11	1B1	136131-15-038 ¹	136131-10-035 ¹
	265	136134-15-038 ¹	136134-10-035 ¹
THROW IN WIRE #12	1B1	136131-02-040 ¹	136131-05-010 ¹
	265	136134-02-040 ¹	136134-05-010 ¹
THROW IN WIRE #13	1B1	136131-04-050 ⁶	136131-02-074 (9PC)
	265	136134-04-050 ⁶	136134-02-074 (9PC)
THROW IN WIRE #14	1B1	136131-02-029 (25Y)	136131-15-006 ⁷
	265	136134-02-029 (25Y)	136134-15-006 ⁷

CONNECTOR-WIRE,NM,CLEAR
144283-02-000

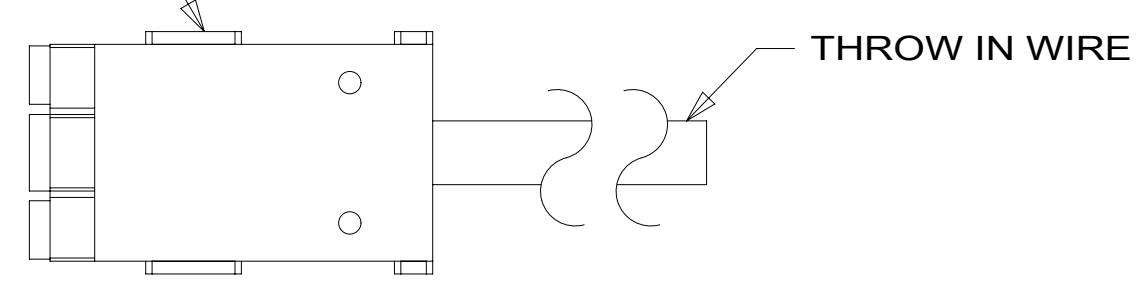

DETAIL BA

CONNECTOR-WIRE,SOW,BLUE
144283-01-000 (2)

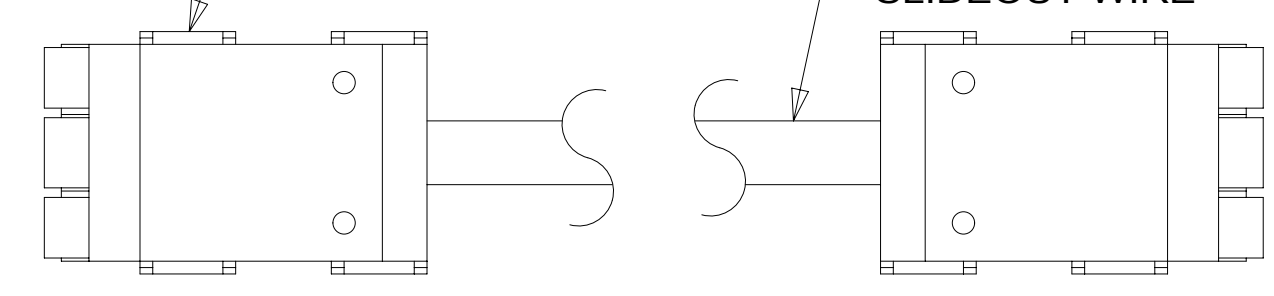

DETAIL BB

CONNECTOR-WIRE,NM,CLEAR
144283-02-000 (2)

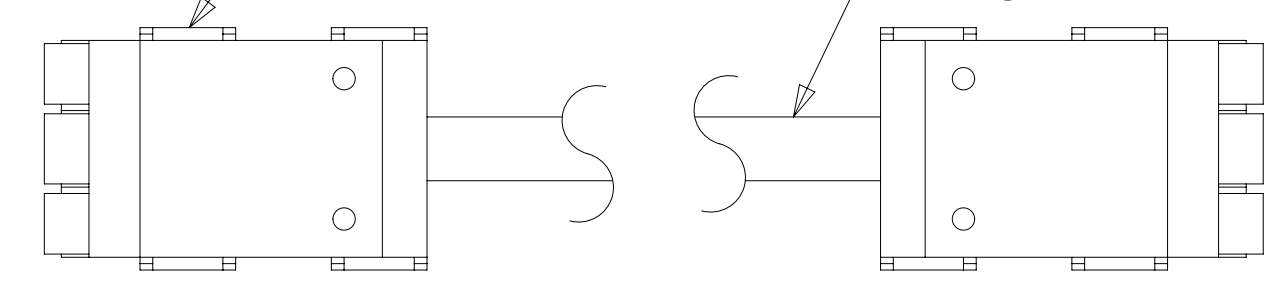

DETAIL BD

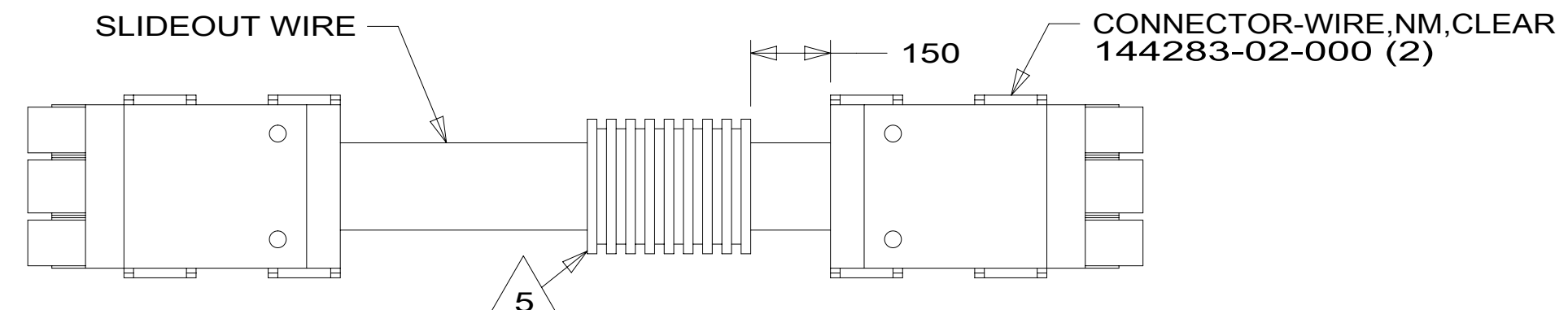

DETAIL BC

- NOTES:
- ⁶ SEE DETAIL AC.
 - ⁶ SEE DETAIL BD FOR CONNECTOR INSTALLATION.
 - ⁵ APPLY 300MM OF CONDUIT-CONVOLUTE 41953-05-000 OVER WIRE AT DIMENSION SHOWN AND SECURE BOTH ENDS OF TUBING TO WIRE WITH TAPE 8363-01-000.
 - ⁴ SEE DETAIL BC FOR CONNECTOR INSTALLATION.
 - ³ SEE DETAIL AB FOR CONNECTOR INSTALLATION.
 - ² SEE DETAIL BB FOR CONNECTOR INSTALLATION.
 - ¹ SEE DETAIL BA FOR CONNECTOR INSTALLATION.

FOR ELECTRICAL TORQUE SPECIFICATIONS SEE DWG NO. 128783-01-000

FOR ELECTRICAL CALLOUTS SEE DWG NO. 121339-01-000

- (25Y) HOMETHEATER SOUNDBAR SYS-PRM
- (9PC) TAILGATE PACKAGE
- (214) DISHWASHER DRAWER STYLE
- (265) CODES/STANDARDS-CSA/CMVSS
- (1B1) CODES/STANDARDS-USA

1B1 265

FIRST USED

15 R-SERIES

DO NOT SCALE DRAWING

TITLE: LOAD CENTER/ATS ASM

SHEET 2 PART NO 187612 REV

12-Nov-2015

187612

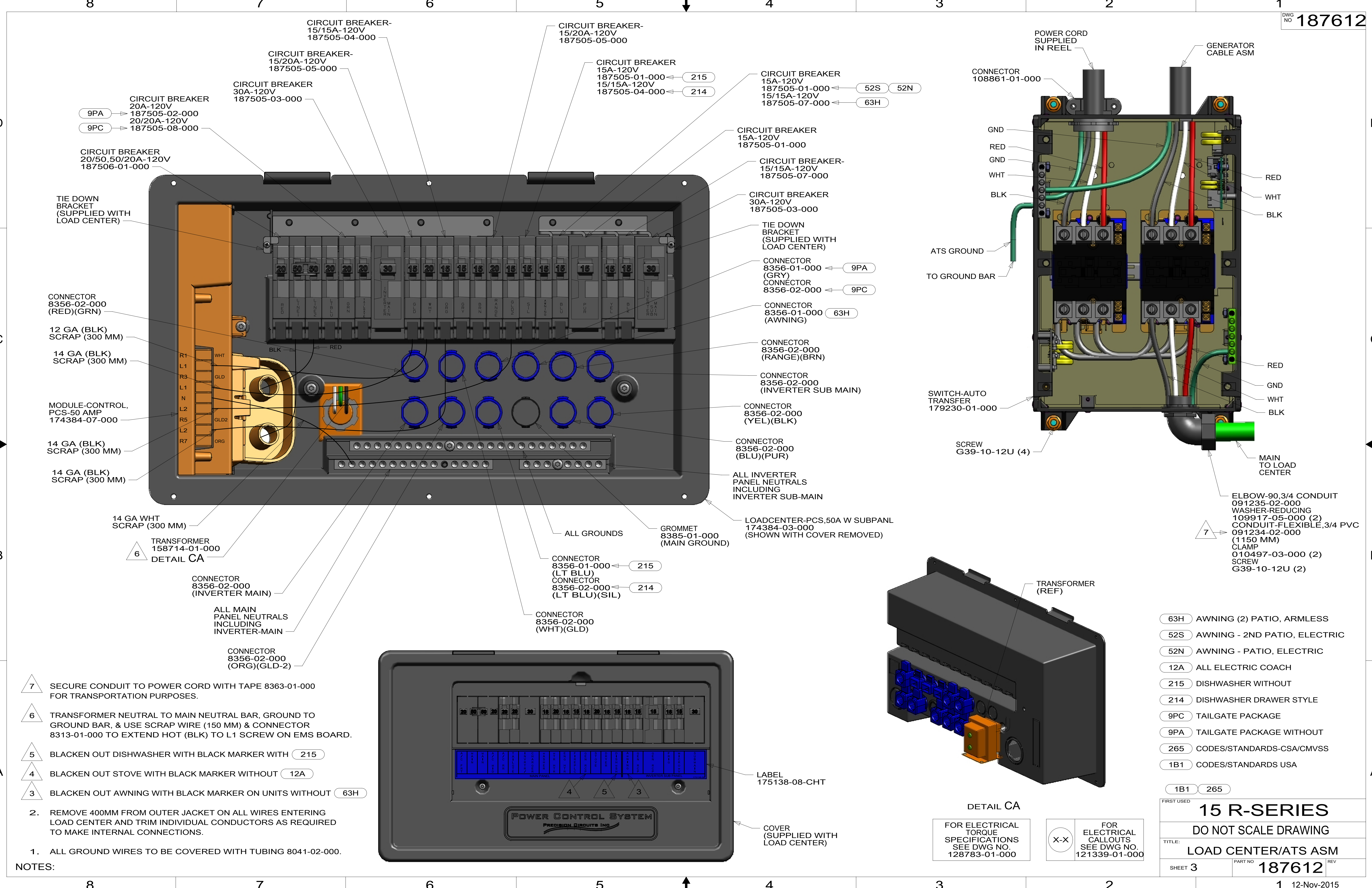

- NOTES:**
1. ALL GROUND WIRES TO BE COVERED WITH TUBING 8041-02-000.
 2. REMOVE 400MM FROM OUTER JACKET ON ALL WIRES ENTERING LOAD CENTER AND TRIM INDIVIDUAL CONDUCTORS AS REQUIRED TO MAKE INTERNAL CONNECTIONS.
 3. BLACKEN OUT AWNING WITH BLACK MARKER ON UNITS WITHOUT 63H
 4. BLACKEN OUT STOVE WITH BLACK MARKER WITHOUT 12A
 5. BLACKEN OUT DISHWASHER WITH BLACK MARKER WITH 215
 6. TRANSFORMER NEUTRAL TO MAIN NEUTRAL BAR, GROUND TO GROUND BAR, & USE SCRAP WIRE (150 MM) & CONNECTOR 8313-01-000 TO EXTEND HOT (BLK) TO L1 SCREW ON EMS BOARD.
 7. SECURE CONDUIT TO POWER CORD WITH TAPE 8363-01-000 FOR TRANSPORTATION PURPOSES.

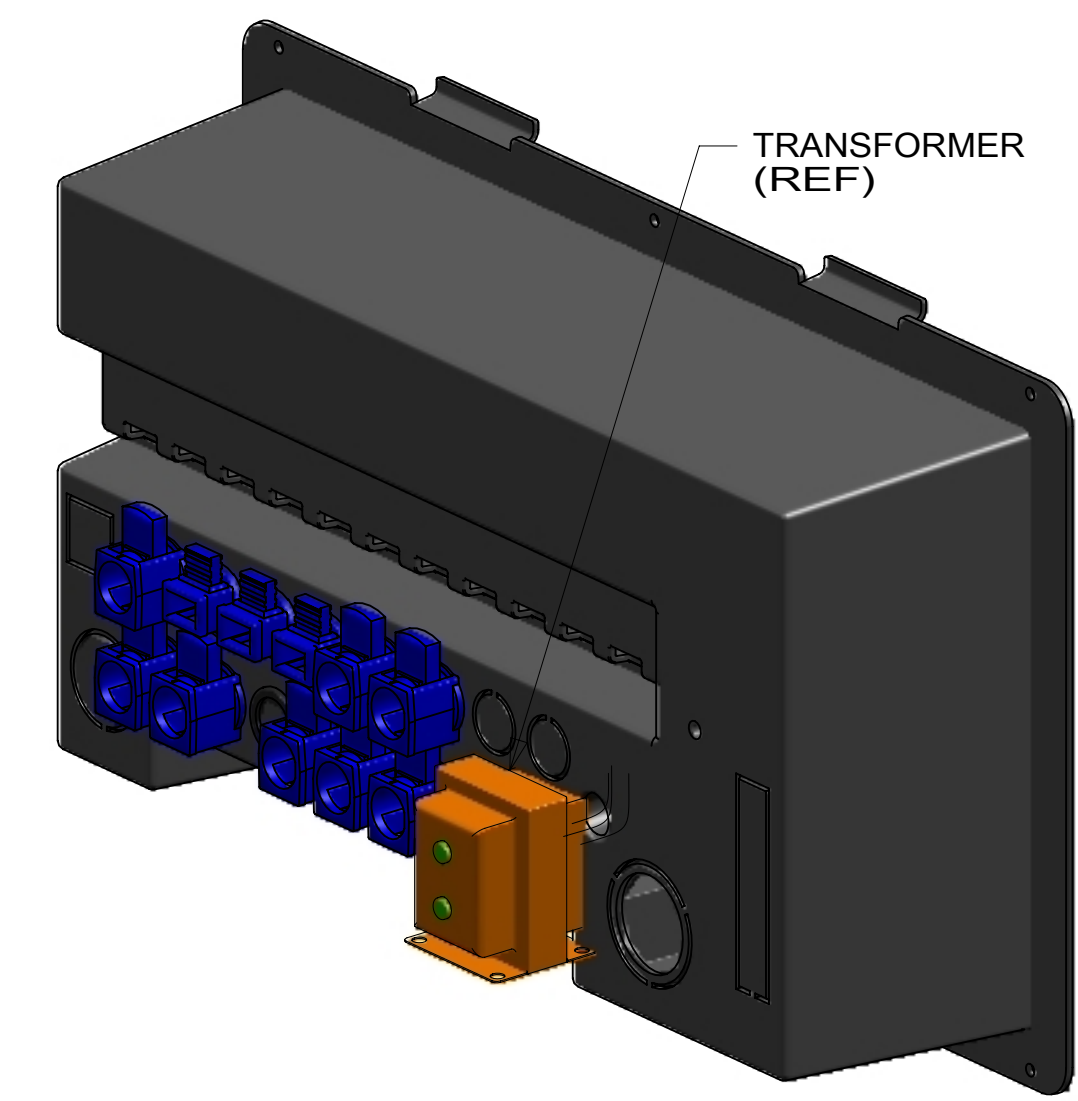
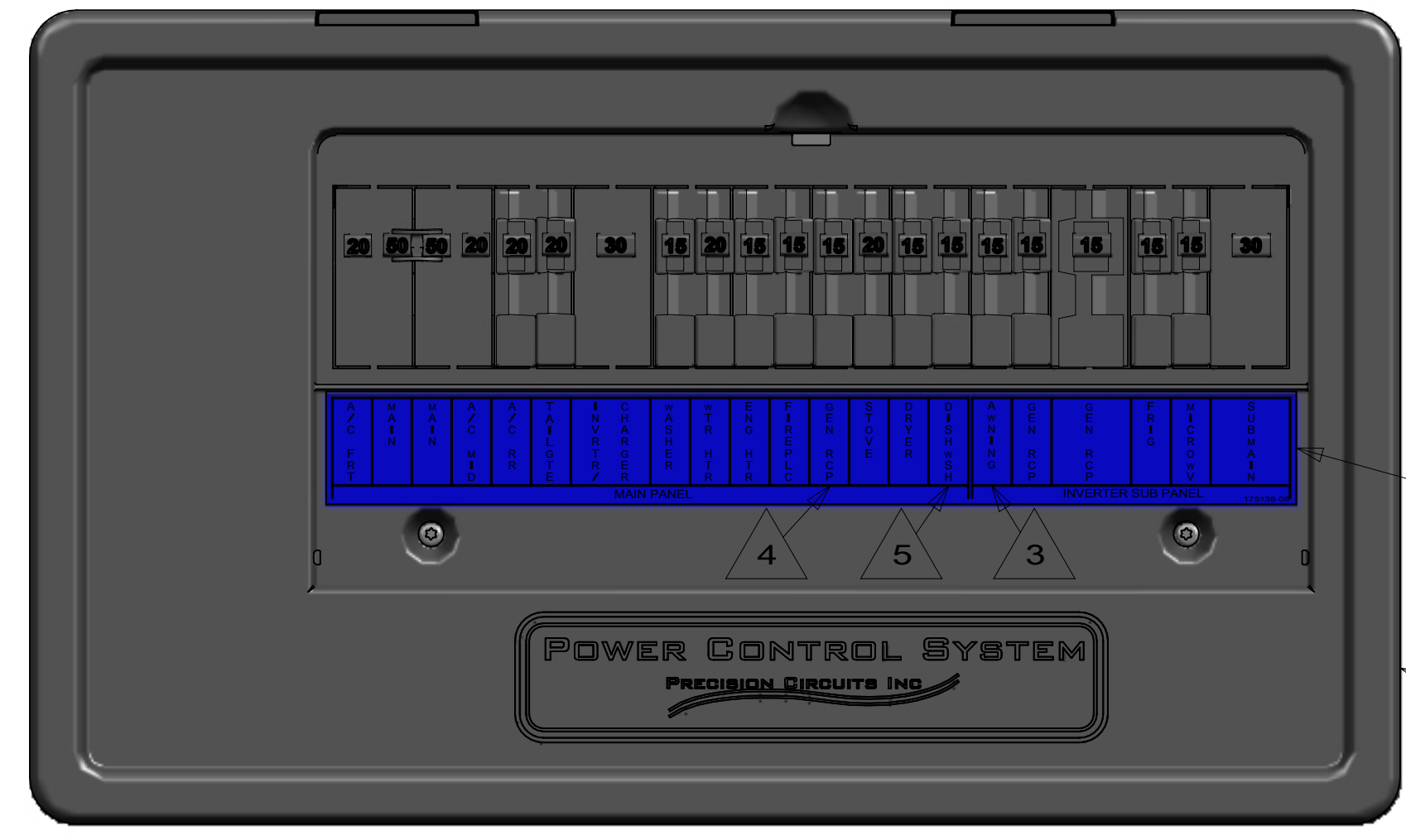

FOR ELECTRICAL TORQUE SPECIFICATIONS SEE DWG NO. 128783-01-000

FOR ELECTRICAL CALLOUTS SEE DWG NO. 121339-01-000

- 63H AWNING (2) PATIO, ARMLESS
- 52S AWNING - 2ND PATIO, ELECTRIC
- 52N AWNING - PATIO, ELECTRIC
- 12A ALL ELECTRIC COACH
- 215 DISHWASHER WITHOUT
- 214 DISHWASHER DRAWER STYLE
- 9PC TAILGATE PACKAGE
- 9PA TAILGATE PACKAGE WITHOUT
- 265 CODES/STANDARDS-CSA/CMVSS
- 1B1 CODES/STANDARDS USA

1B1	265
FIRST USED	
15 R-SERIES	
DO NOT SCALE DRAWING	
TITLE: LOAD CENTER/ATS ASM	
SHEET 3	PART NO 187612 REV
1 12-Nov-2015	

187612