

- 9. ALL CRIMP FITTINGS TO 3/4" PEX TUBING REQUIRE 3/4" CLAMP 140171-05-000.
- 8. ALL CRIMP FITTINGS TO 1/2" PEX TUBING REQUIRE 1/2" CLAMP 140171-03-000.
- 7. ALL CRIMP FITTINGS TO 5/8" FLEX TUBING REQUIRE 5/8" CLAMP 140171-04-000.
- 6 LABEL HOT AND COLD SUPPLY TUBES AND TAPE FITTING TO TUBE BEFORE CABINET SET TO PREVENT MOVEMENT.
- 5 ADD PIPE WRAP (LADDER SCRAP 110157-02-000) INSULATION.
- 4 ADD TEFLON TAPE 010405-01-000.
- 3. ALL TUBING TO BE SECURED AT 1200 INTERVALS MAXIMUM WITH CLAMP 010495-01-000 AND SCREW 000G67-10-12U OR EQUIVALENT.
- 2. TUBING TO BE INSTALLED WITH SUFFICIENT SLOPE TO PROVIDE DRAINAGE TO NEAREST VALVE.
- 1. PLASTIC FITTINGS TO BE SEALED WITH SEALANT 084456-01-000.

- 1BT WATER HEATER-TANKLESS
- 53B WTR HTR-6 GAL ELECTRIC/LP GAS
- 29B WATER PURIFIER
- 501 WATER PURIFIER-WITHOUT
- 53E WATER SYS WINTERIZATION PKG

WINNEBAGO
COPYRIGHT 2016 WINNEBAGO INDUSTRIES, INC.

DSNR:		ALL DIMENSIONS ARE IN MILLIMETERS											
DIFTR:		<table border="1"> <tr> <td>UNSPECIFIED TOLERANCES:</td> <td></td> </tr> <tr> <td>WHOLE DIM (X)</td> <td>3</td> </tr> <tr> <td>ONE-PLACE (X.X)</td> <td>1.5</td> </tr> <tr> <td>TWO-PLACE (X.XX)</td> <td>0.50</td> </tr> <tr> <td>ANGLE</td> <td>1°</td> </tr> </table>		UNSPECIFIED TOLERANCES:		WHOLE DIM (X)	3	ONE-PLACE (X.X)	1.5	TWO-PLACE (X.XX)	0.50	ANGLE	1°
UNSPECIFIED TOLERANCES:													
WHOLE DIM (X)	3												
ONE-PLACE (X.X)	1.5												
TWO-PLACE (X.XX)	0.50												
ANGLE	1°												
REFER TO ES0018 FOR FASTENER TIGHTENING GUIDELINES		WEIGHT: (LBS)	FIRST USED: (REF)										
DESCRIPTION: WATER SYSTEM INSTL													
SHEET: 1 OF 4	ITEM/PART NO: 000209676 / 30147501000	REV:											

X-X
FOR WATER CALLOUTS SEE DWG NO. 116230-01-000

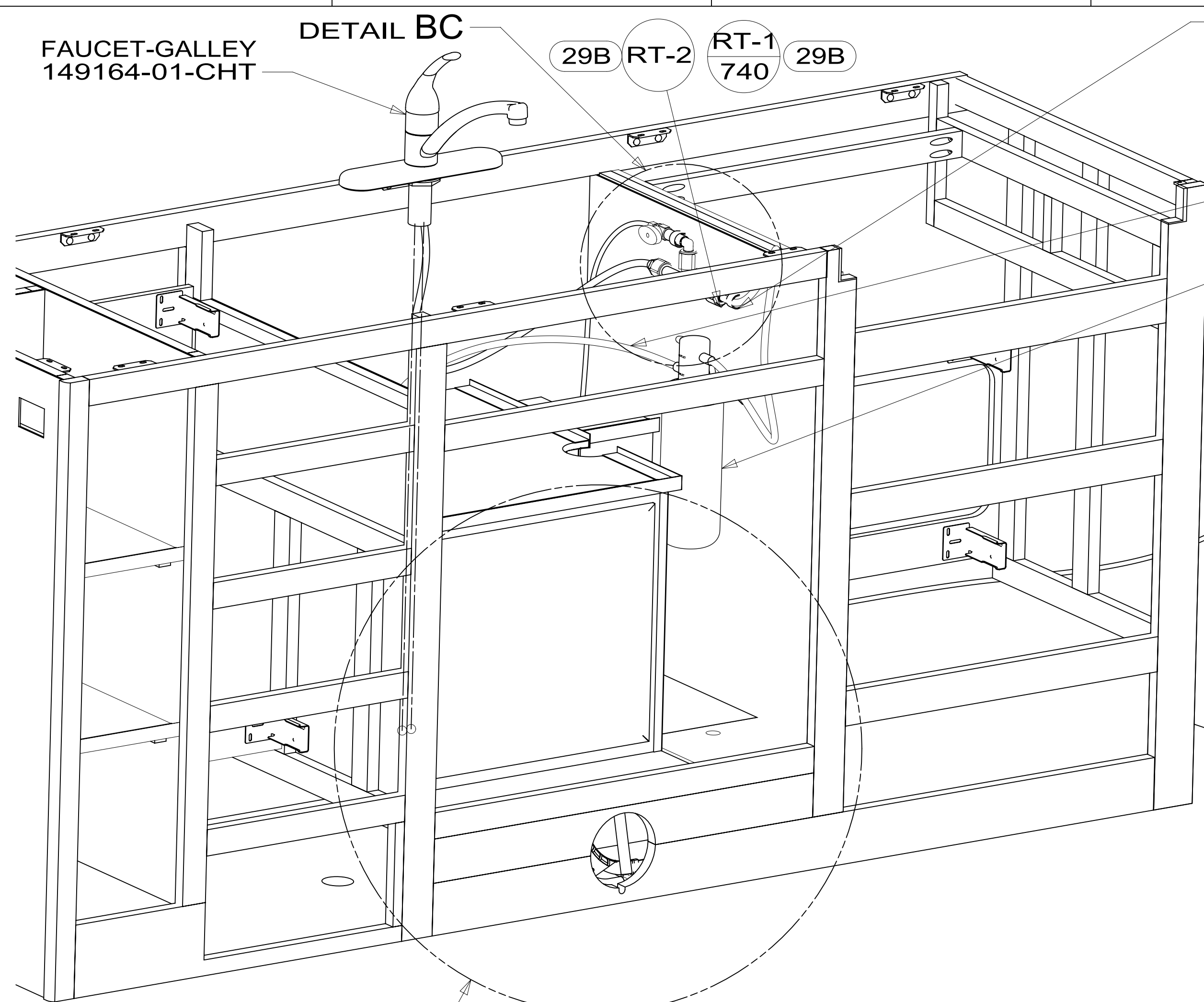

- CLAMP 010495-04-000 29B
- SCREW 000G67-10-12U 29B
- 29B 29B
- RT-2 RT-1 680

- FILTER KIT-WATER, SINK 29B
- 160946-03-000
- SCREW 000G67-10-12U (2)

- I-3 29B & 79W
- I-1 29B & 79W
- I-2 29B & 79W

- CLAMP 010497-03-000 (2)
- SCREW 000G67-08-12U (2)

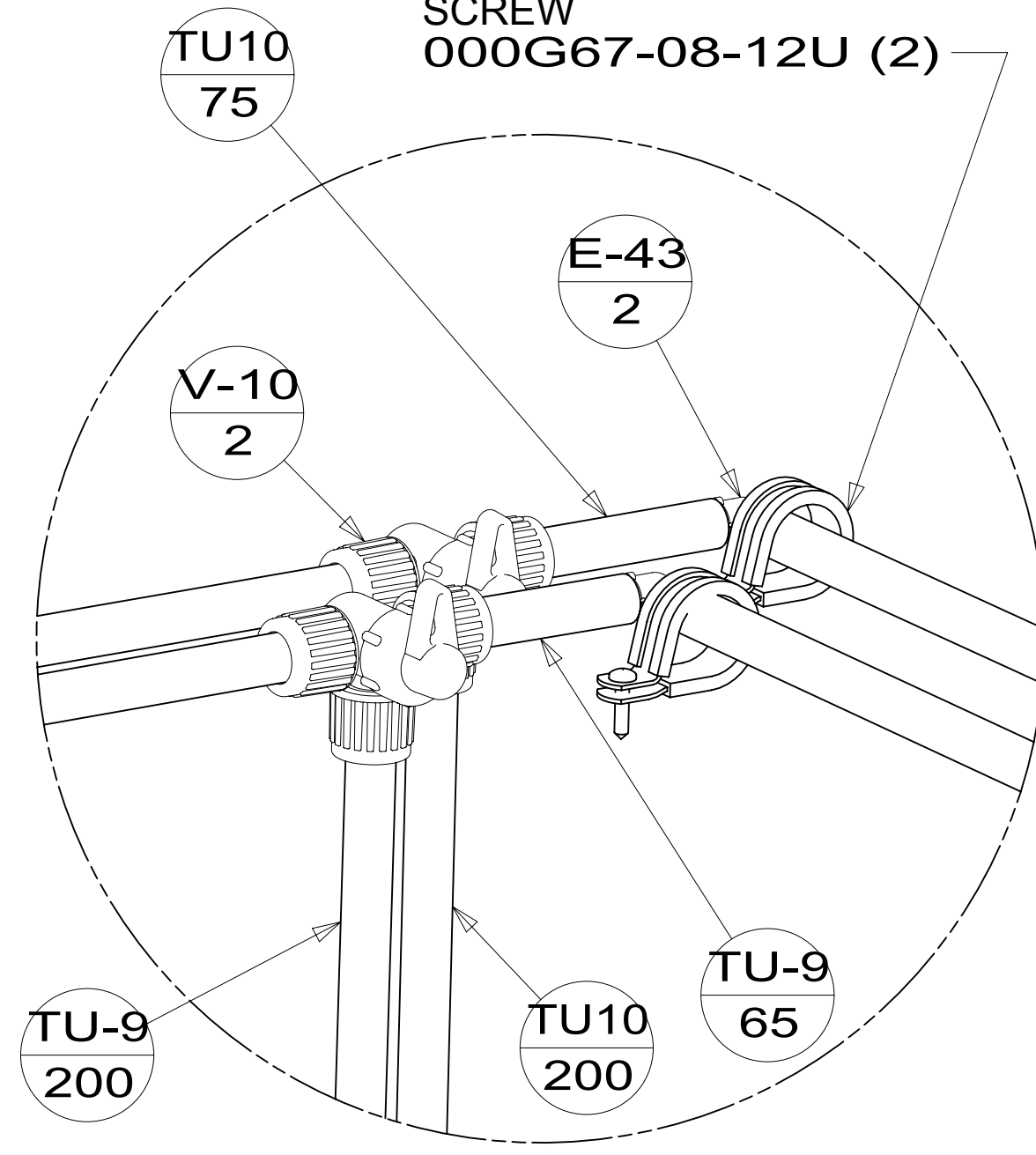

- WATER HEATER INSTL 186899-03-000
- CABLE 076767-03-000
- SCREW 000G11-06-08U (2)

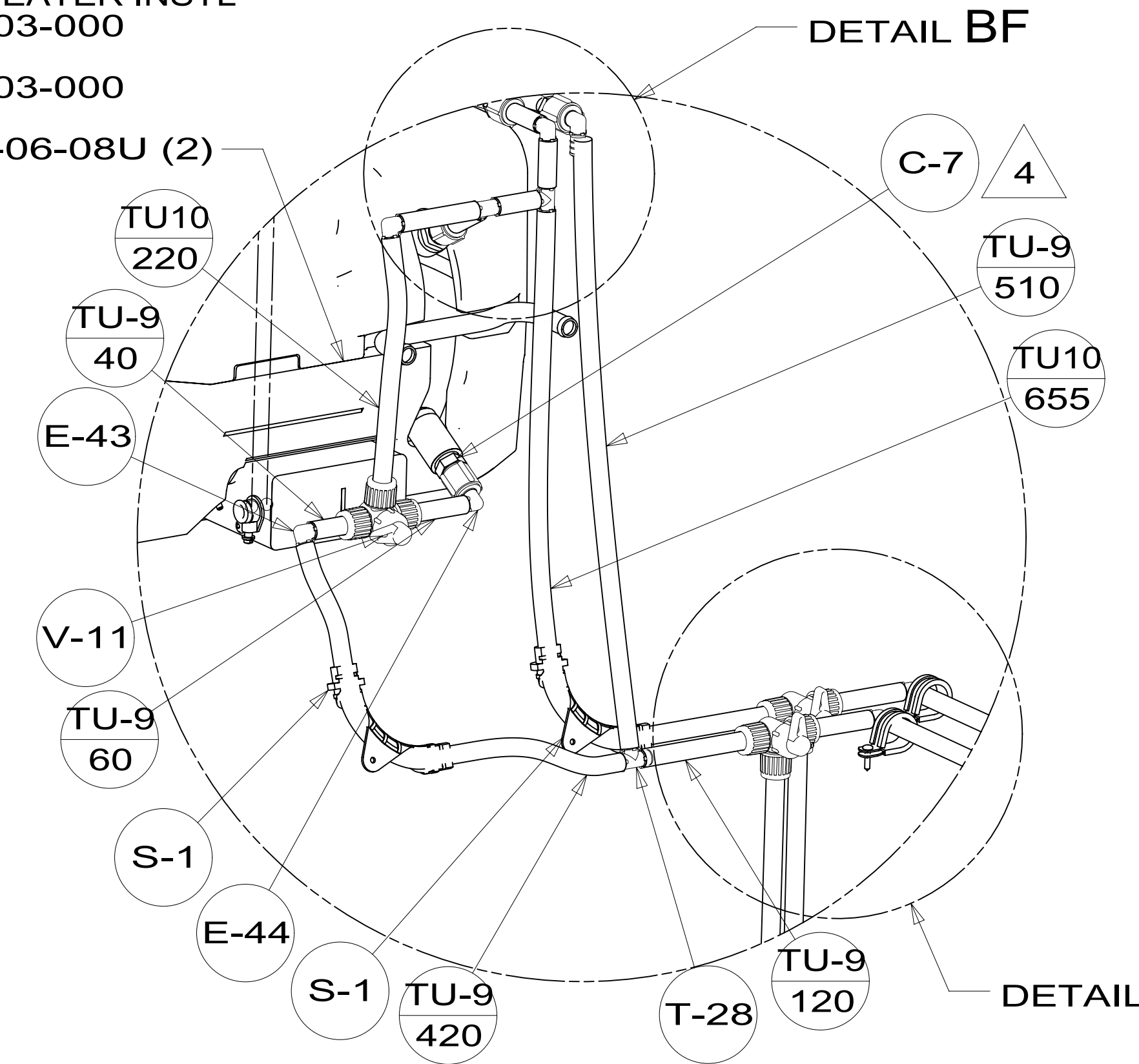

DETAIL BB
(SHOWN W/OUT CABINETS & FLOOR)
53B

DETAIL BB

VIEW BA

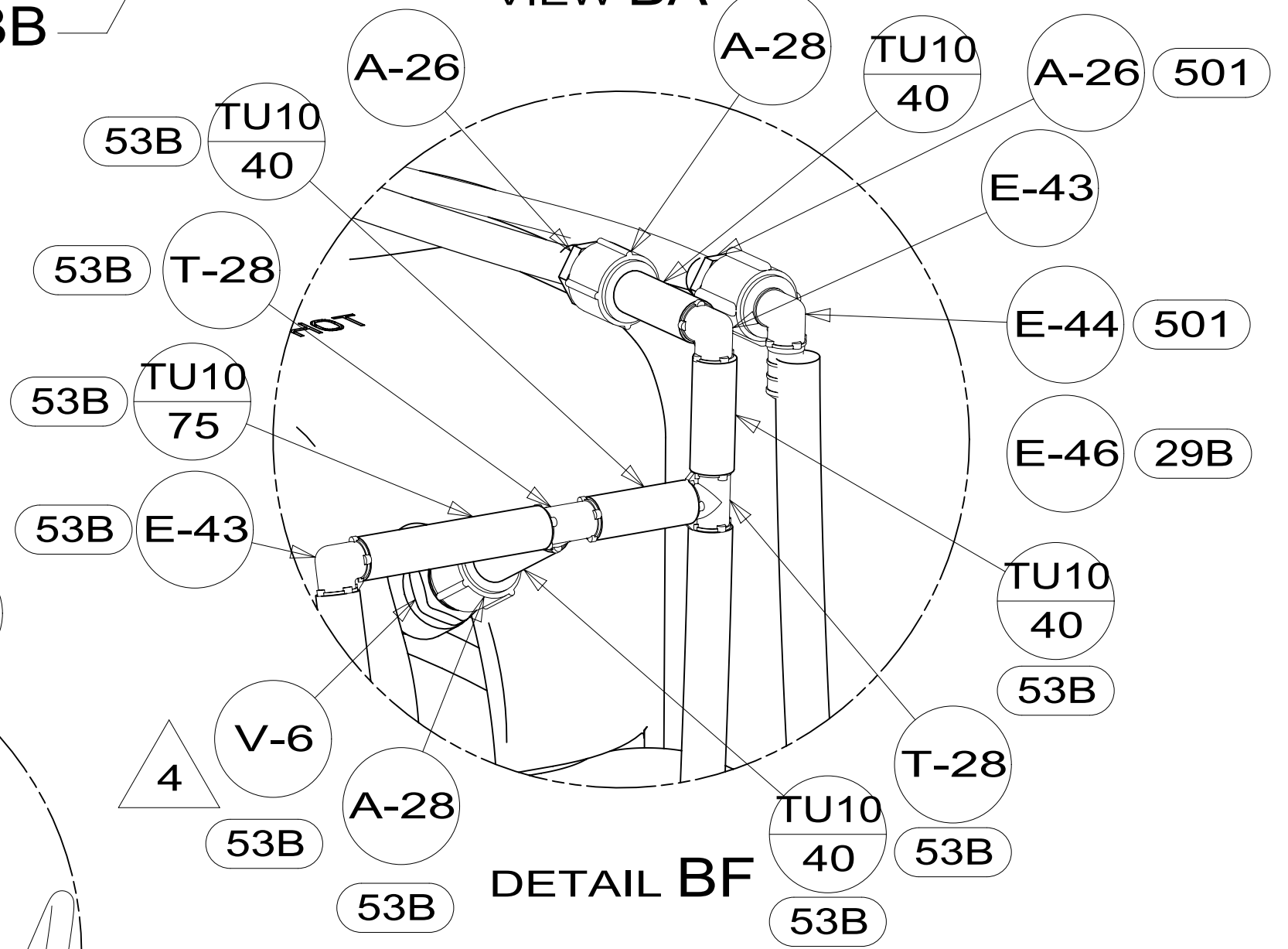

DETAIL BF

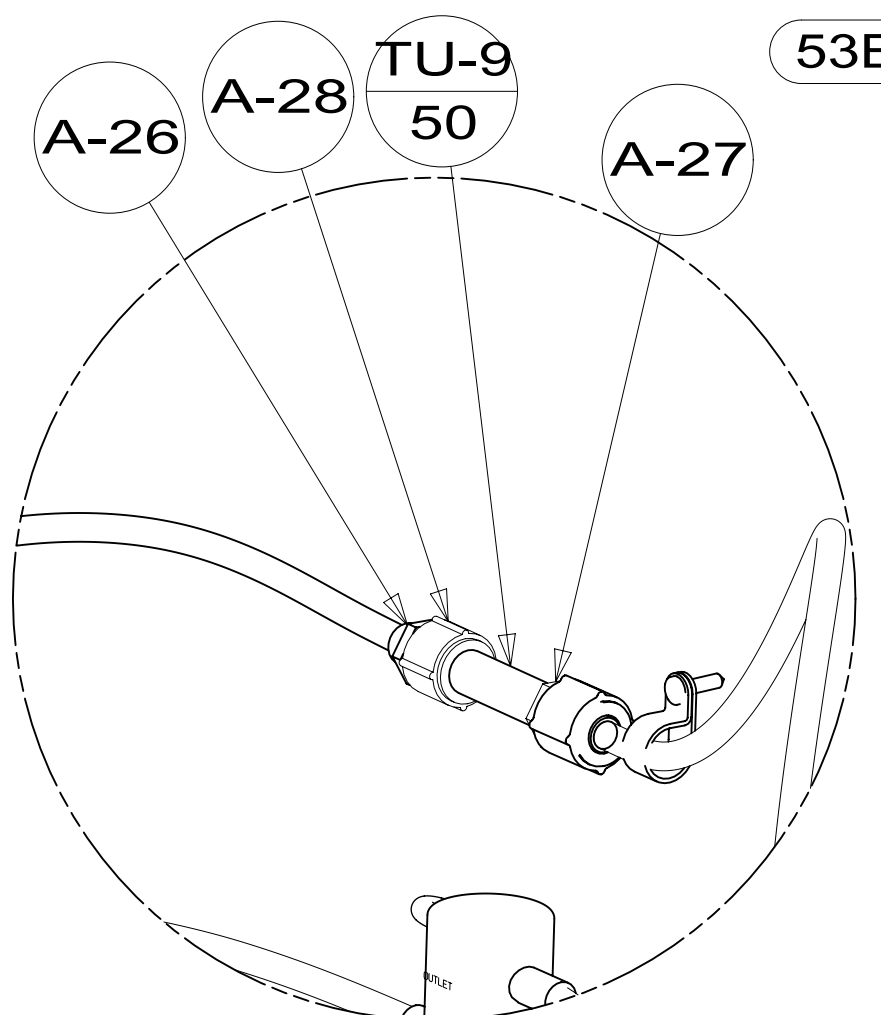

DETAIL BC
(SHOWN W/OUT CABINETS)
29B & 144

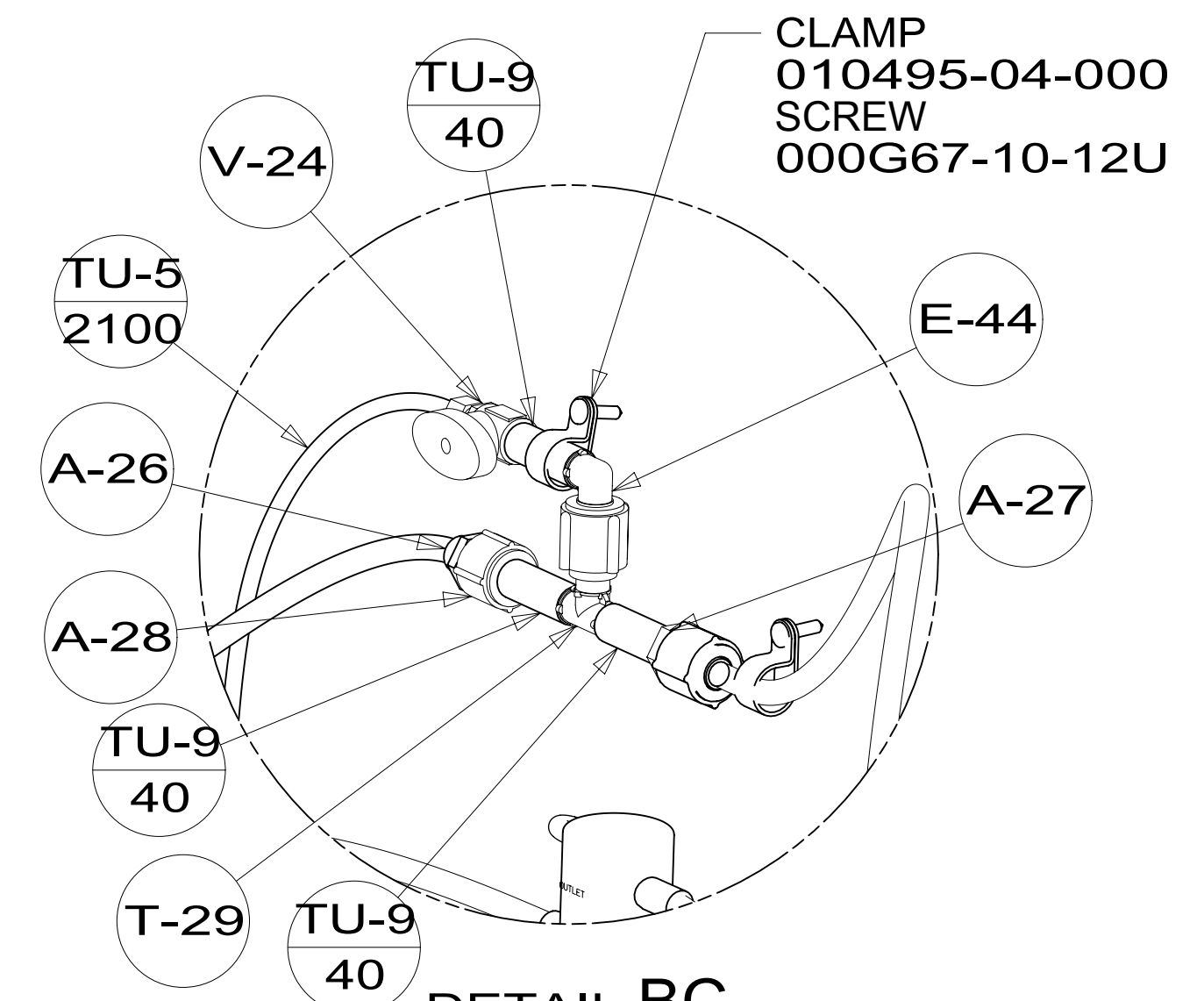

DETAIL BC
(SHOWN W/OUT CABINETS)
29B & 79W

DETAIL BE

- WATER HEATER INSTL 301919-01-000

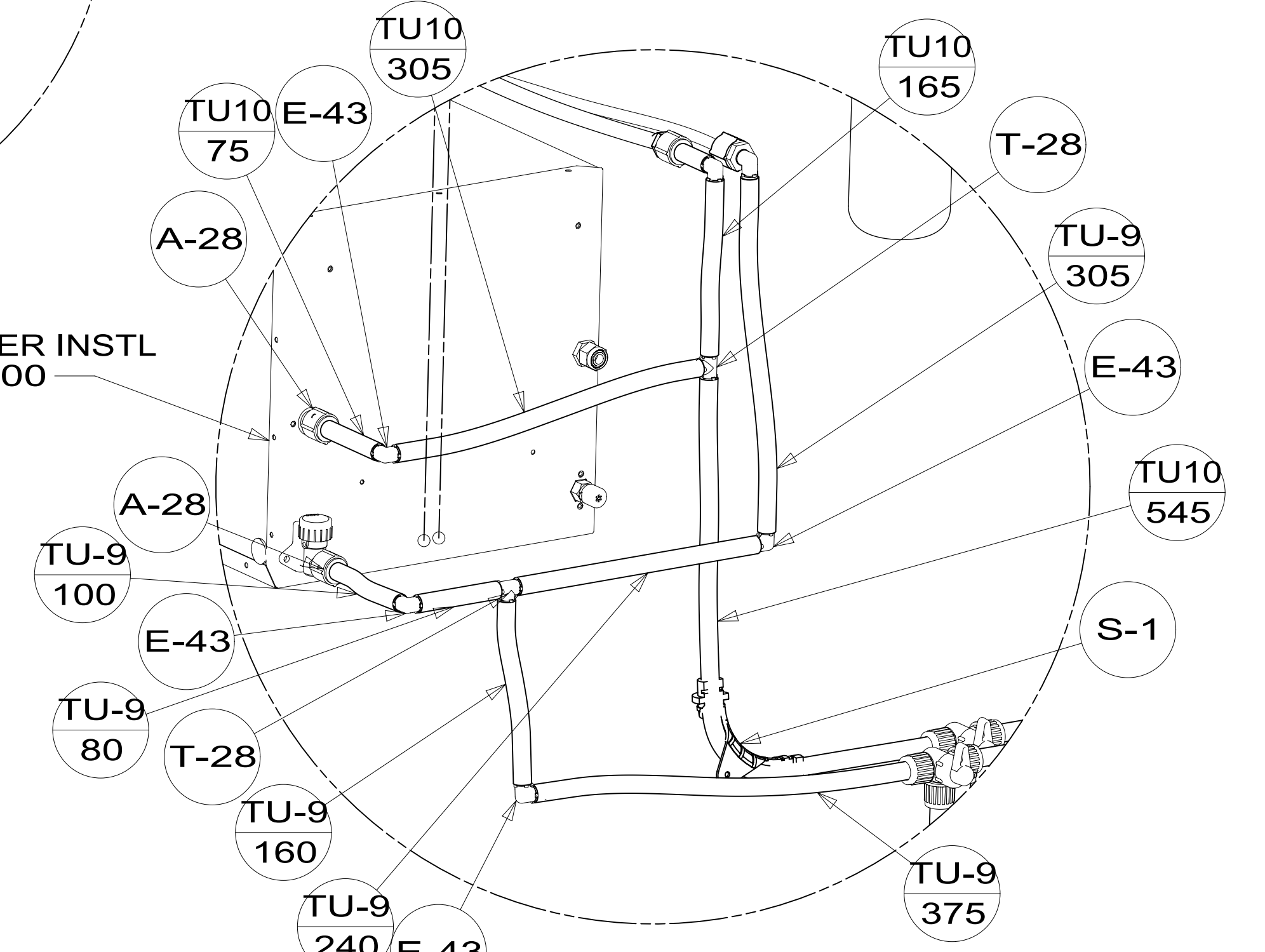

DETAIL BB
(SHOWN W/OUT CABINETS & FLOOR)
1BT

DESCRIPTION:		
WATER SYSTEM INSTL		
SHEET:	ITEM/PART NO.:	REV:
2 OF 4	000209676 / 30147501000	

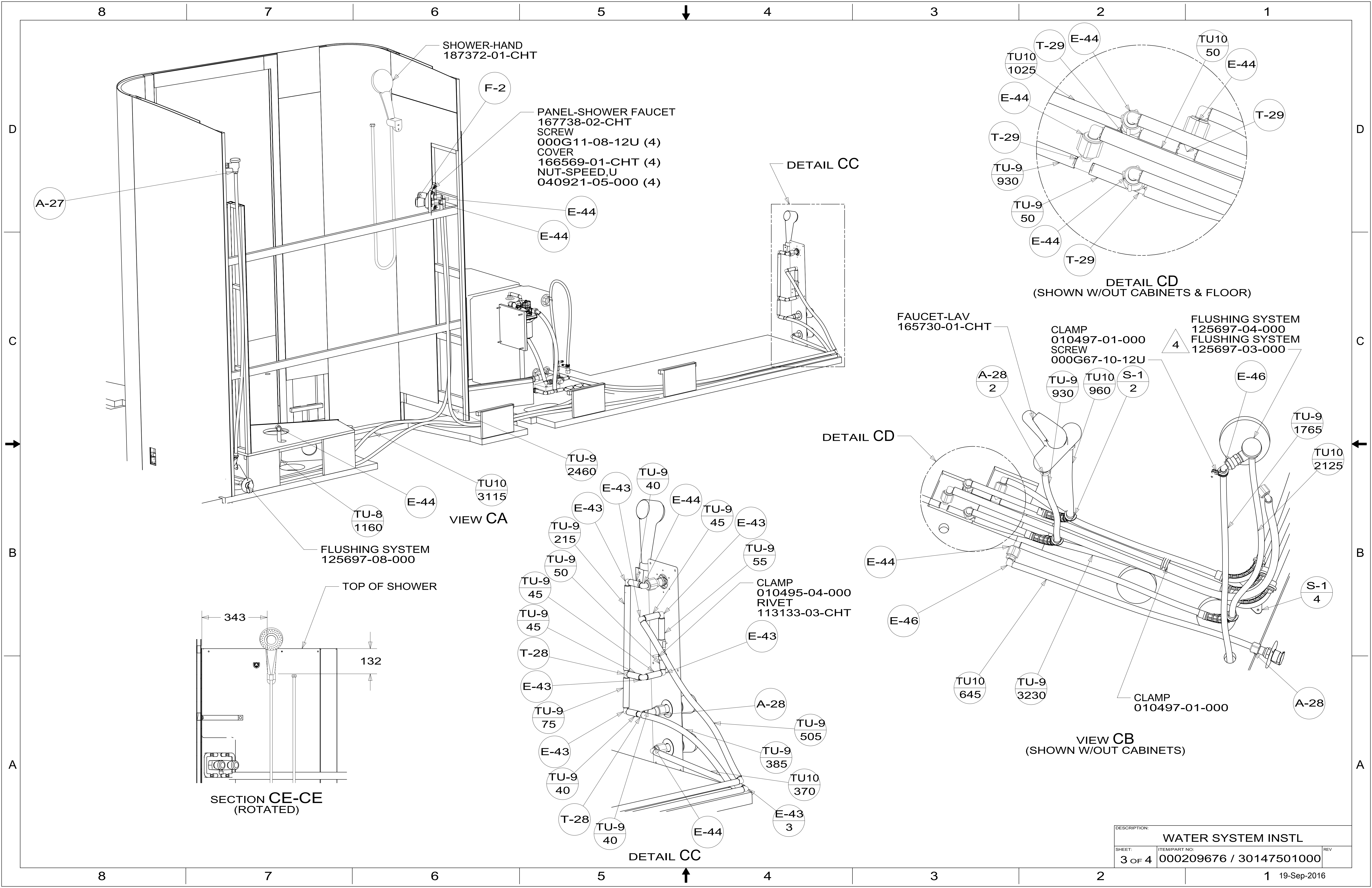

DESCRIPTION:		
WATER SYSTEM INSTL		
SHEET:	ITEM/PART NO:	REV
3 OF 4	000209676 / 30147501000	

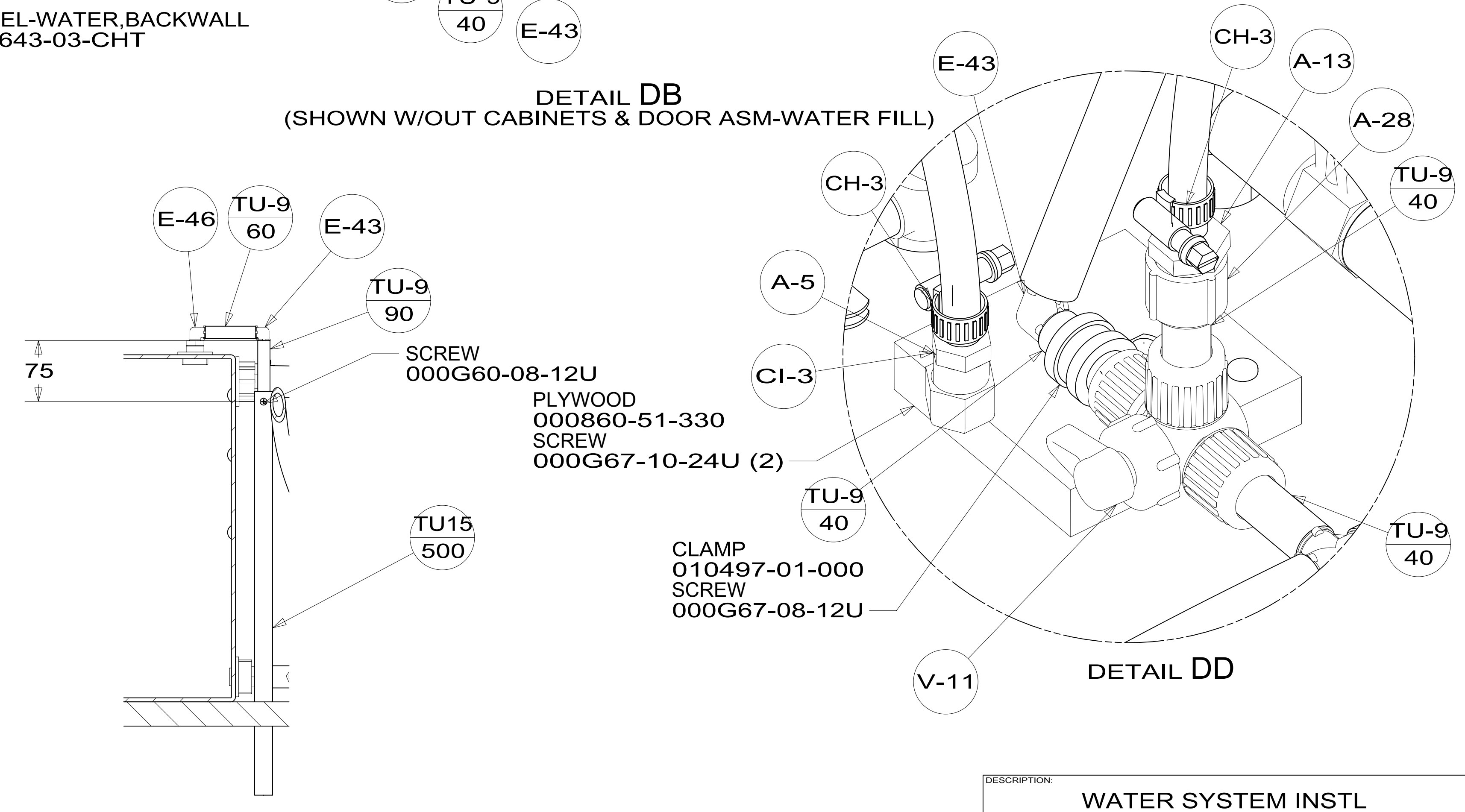
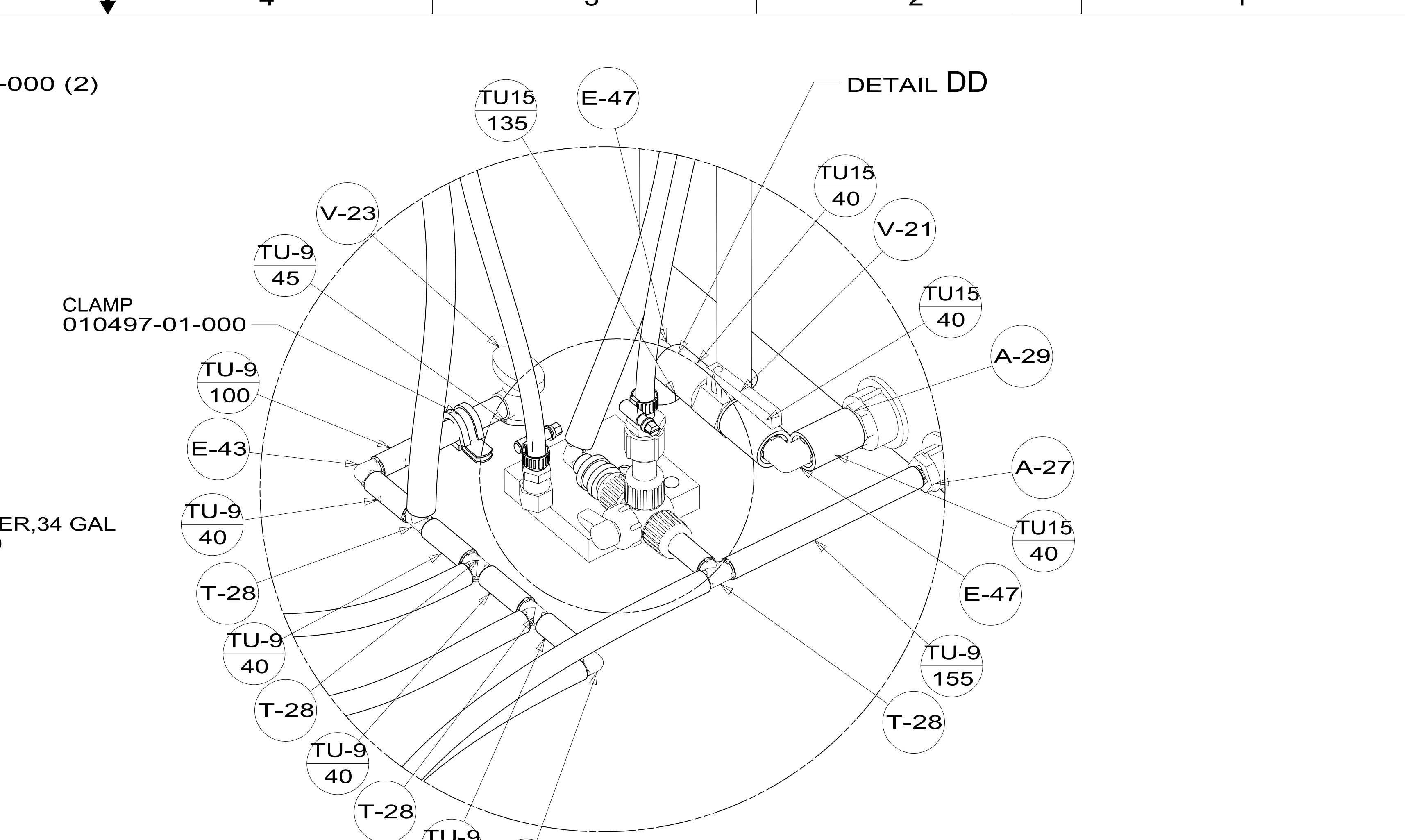
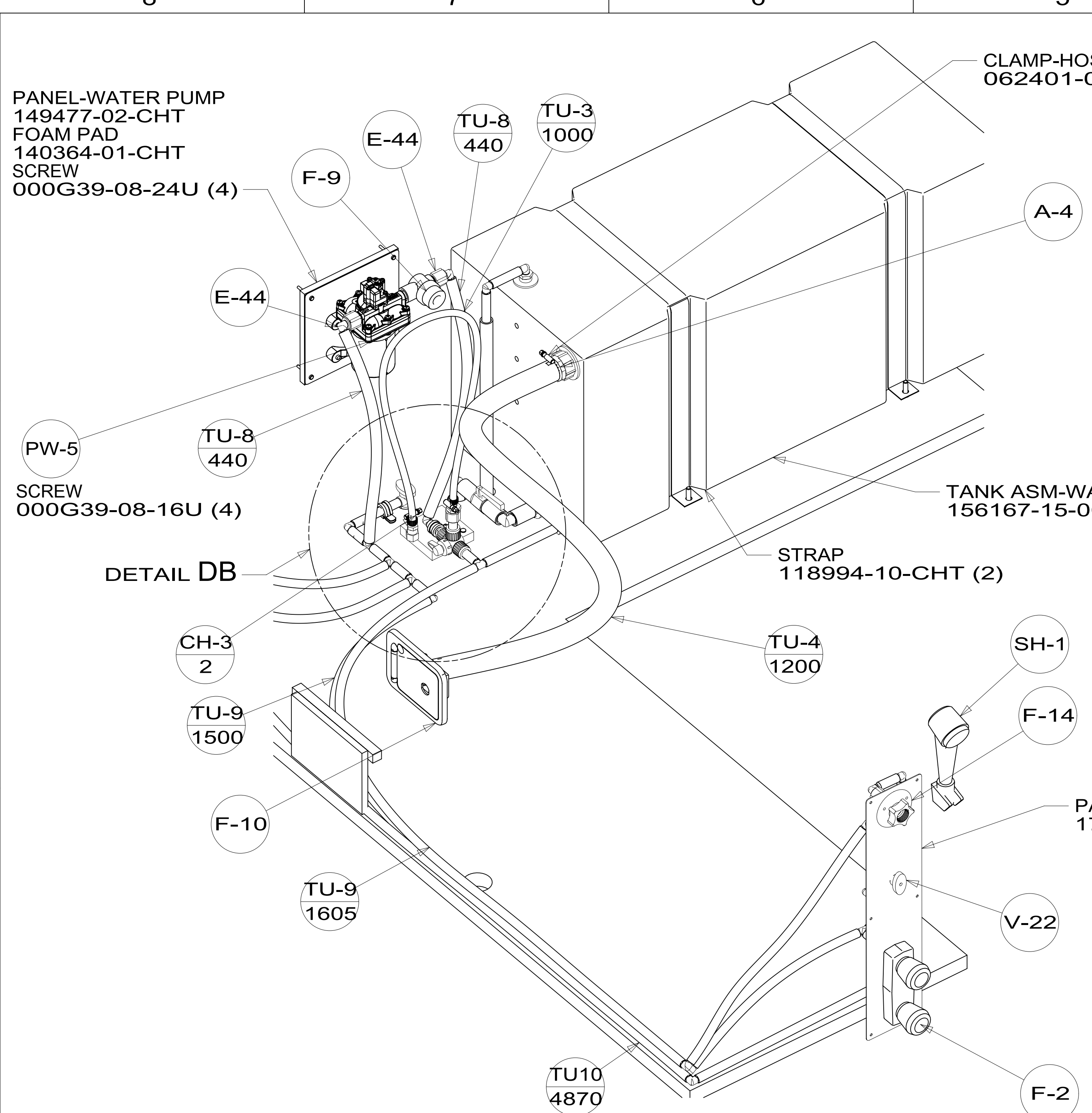

DESCRIPTION: WATER SYSTEM INSTL		
SHEET: 4 OF 4	ITEM/PART NO: 000209676 / 30147501000	REV
		19-Sep-2016