

SOCKET 29 - CIRCUIT FR  
 SOCKET 30 - CIRCUIT DY  
 SOCKET 32 - CIRCUIT BW  
 SOCKET 43 - CIRCUIT GZ

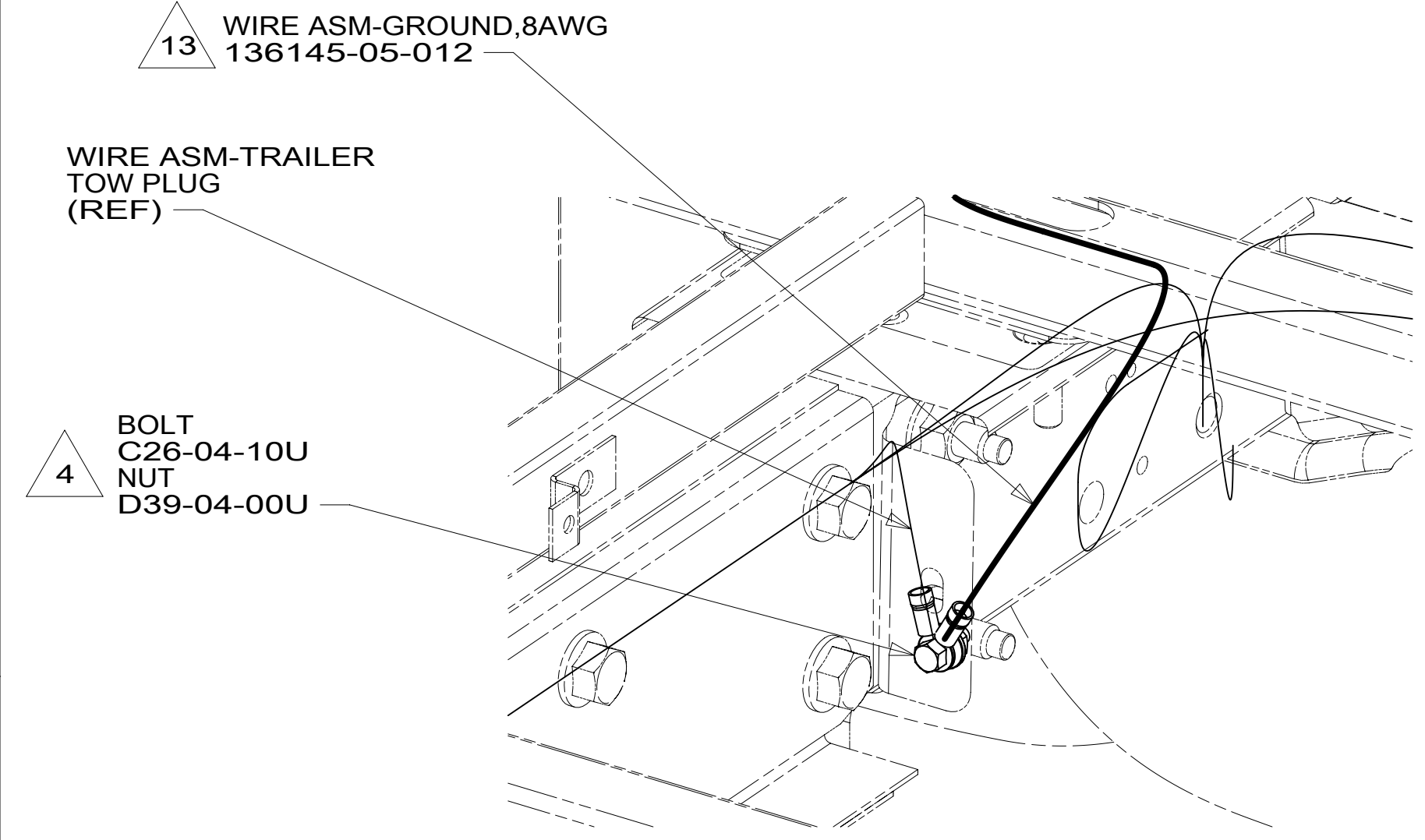

DETAIL AA



DETAIL AC

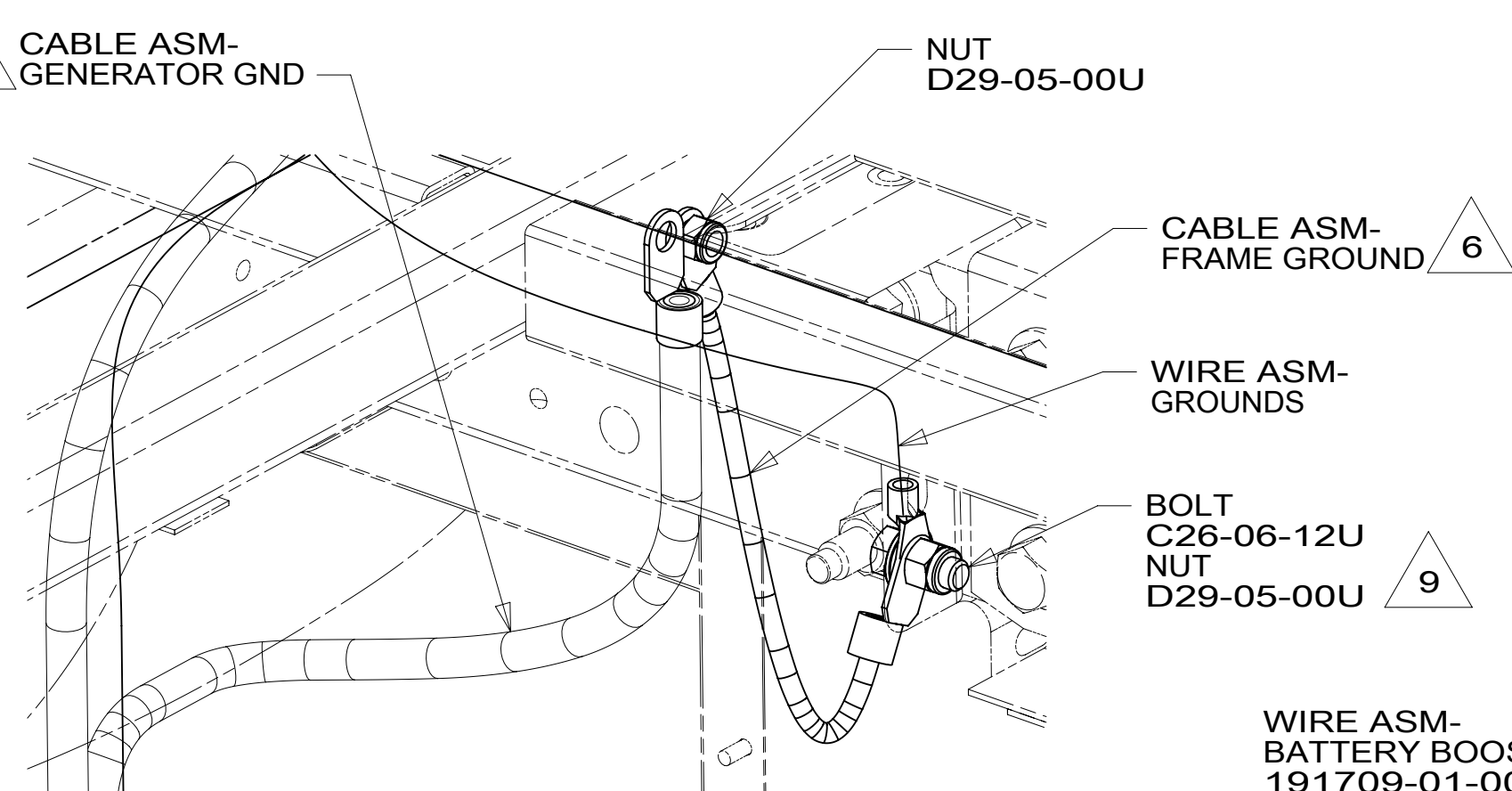

VIEW AB

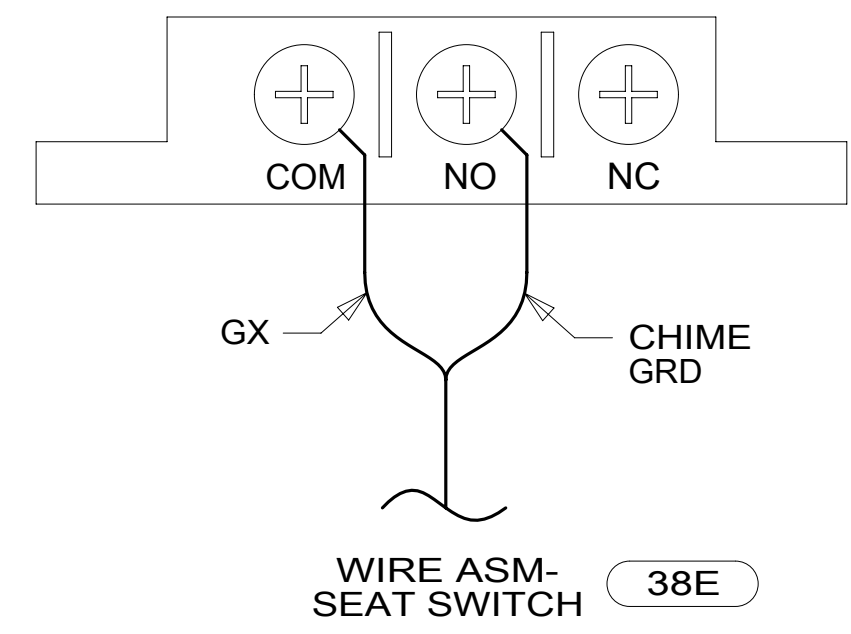

DETAIL AD  
(UNDER PASSENGER SEAT)

- NOTES:**
- 1. SECURE CONDUIT 41953, TAB AS REQUIRED, OVER ALL WIRES IN CONTACT WITH SHARP EDGES.
  - 2. USE WIRE TIES 8343-04-000 AND 116673-02-000 APPROXIMATELY 600MM ON CENTER UNLESS OTHERWISE SPECIFIED.
  - 3. SEE RADIO/MONITOR INSTL FOR ADDITIONAL INFORMATION.
  - 4. DRILL 6.35 MM HOLE IN CHASSIS RAIL FLANGE. CLEAN PAINT FROM FLANGE APPROXIMATELY 10 MM AROUND HOLE. BOLT AND NUT GROUND RING FROM WIRE ASM-TRAILER TOW PLUG TO FLANGE.
  - 5. WIRING IS PART OF WIRE ASM-POWER MIRRORS.
  - 6. SEE BATTERY INSTL FOR ADDITIONAL INFORMATION.
  - 7. 10 PIN HSG CONNECTS TO GENERATOR.
  - 8. ROUTE GENERATOR CABLE ALONG WITH WIRE ASM-CHASSIS TO AND THROUGH FLOOR TO WIRE ASM-RIGHT. ROUTE UP TO MONITOR PANEL AREA.
  - 9. DRILL 10.4 MM HOLE IN CHASSIS RAIL FLANGE. CLEAN PAINT FROM FLANGE APPROXIMATELY 10 MM AROUND HOLE. BOLT AND NUT GROUND TERMINAL TO FLANGE.
  - 10. SEE DETAIL AB FOR CONNECTION OF CABLE ASM TO CHASSIS RAIL.
  - 11. SEE DETAIL AA FOR CONNECTION OF WIRE ASM TO FORD SUPPLIED CONNECTOR LOCATED BEHIND GLOVE BOX.

- 13. SEE LOAD CENTER/ATS ASM FOR ADDITIONAL INFORMATION.
- 12. SEE INTERIOR INSTL-FRONT FOR ADDITIONAL INFORMATION.

FOR ELECTRICAL TORQUE SPECIFICATIONS SEE DWG NO. 128783-01-000

FOR ELECTRICAL CALLOUTS SEE DWG NO. 121339-01-000

- 240 TRAILER HITCH
- 38E CONVENIENCE PACKAGE
- 282 SOLAR PANEL - 100 WATT
- 265 CODES/STANDARDS-CSA/CMVSS
- 1B1 CODES/STANDARDS USA

**WINNEBAGO**  
 COPYRIGHT 2016 WINNEBAGO INDUSTRIES, INC.

DSNR:	ALL DIMENSIONS ARE IN MILLIMETERS	
DFFR:		
UNSPECIFIED TOLERANCES:		MATERIAL:
WHOLE DIM (X)	3	
ONE-PLACE (X.X)	1.5	
TWO-PLACE (X.XX)	0.50	
ANGLE	1°	
REFER TO ES0018 FOR FASTENER TIGHTENING GUIDELINES	WEIGHT: (LBS)	FIRST USED:
		16 423A
DESCRIPTION: <b>WIRING INSTL-CHASSIS</b>		
SHEET: 1 OF 3	ITEM/PART NO: 000209582 / 30101801000	REV:
REF: 1		09-May-2017

8 7 6 5 4 3 2 1

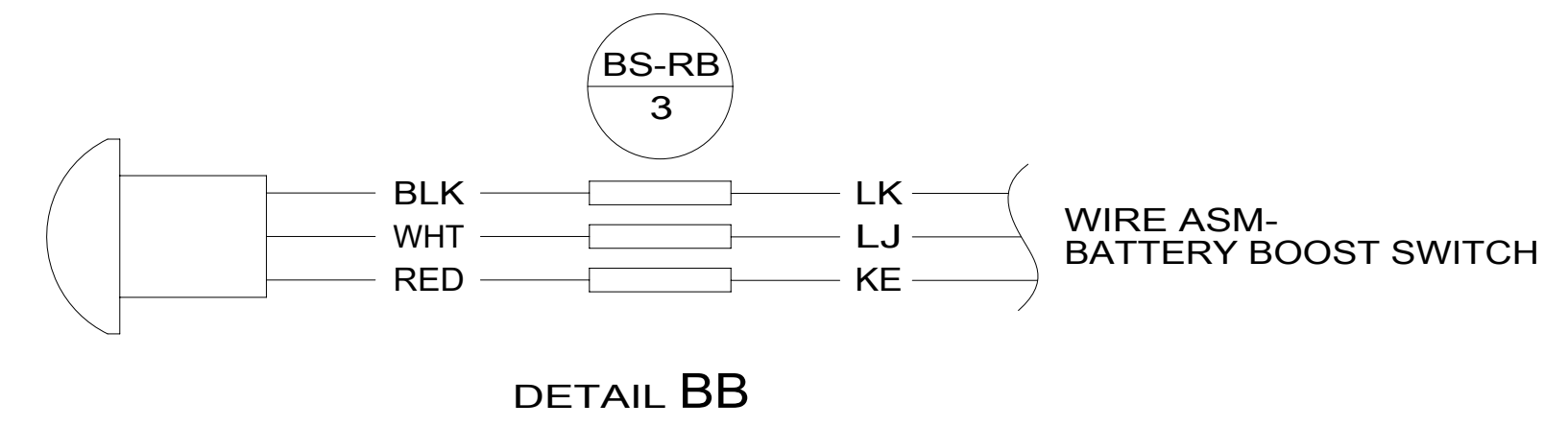
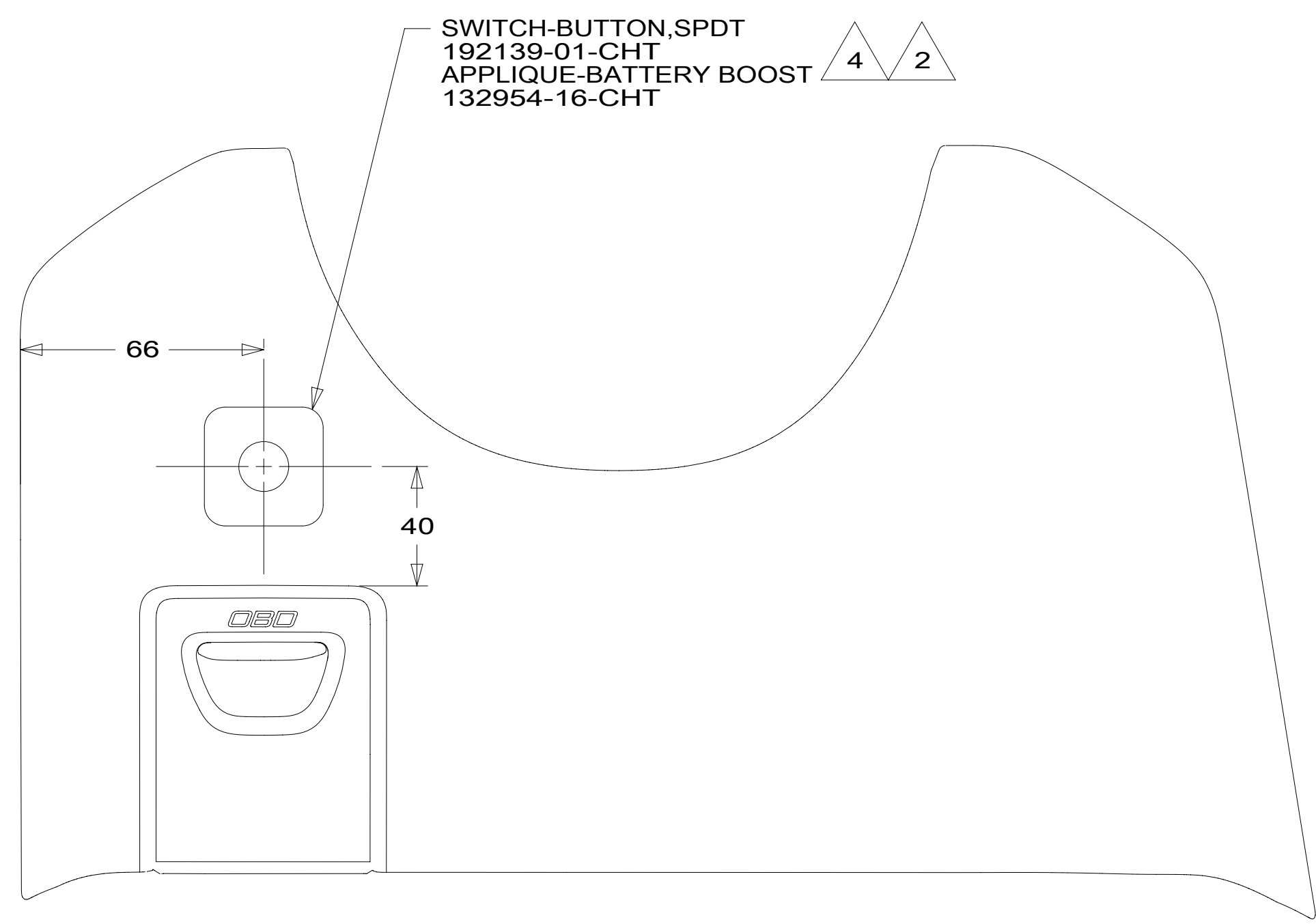
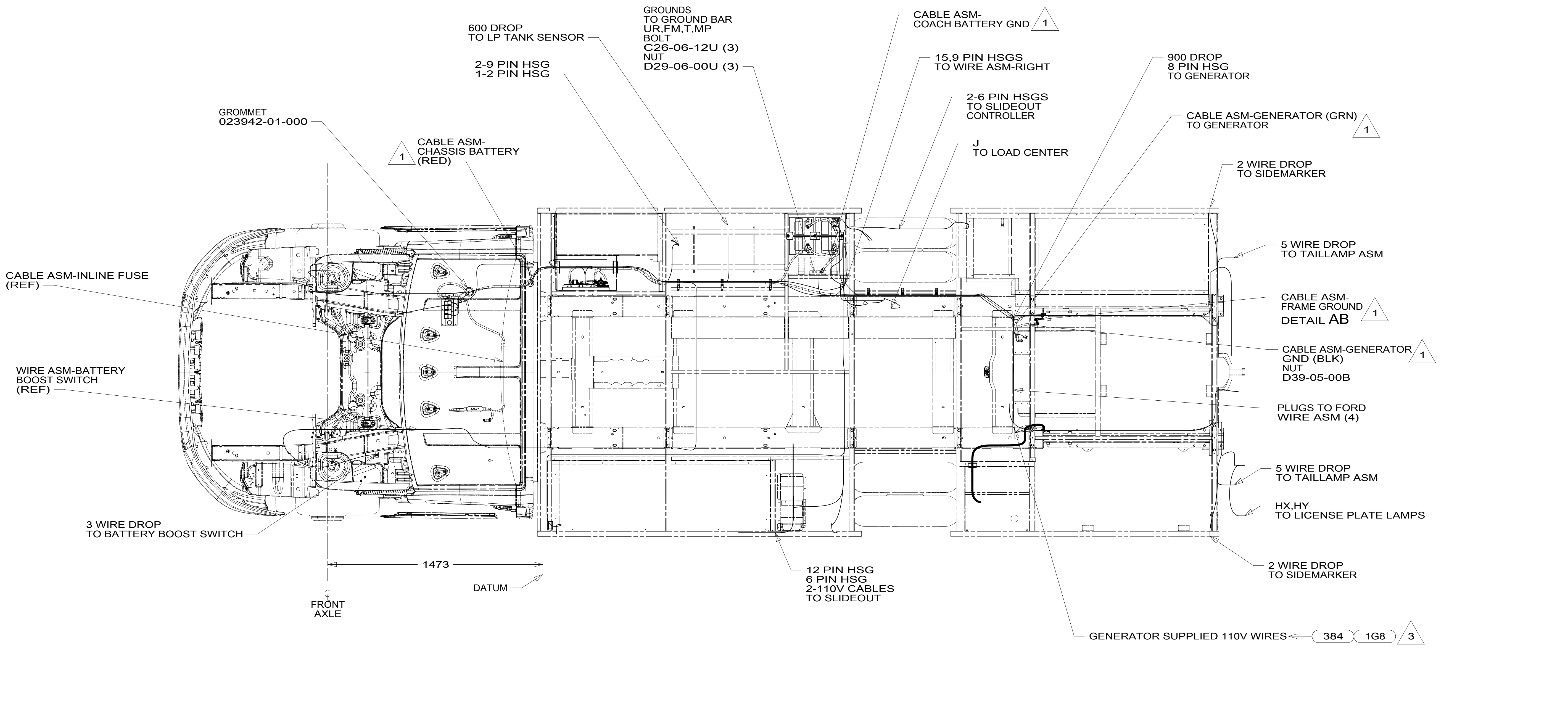

- NOTES:
- 4 SEE DETAIL BB FOR CONNECTION OF BUTTON SWITCH.
  - 3 SEE GENERATOR INSTL FOR ADDITIONAL INFORMATION.
  - 2 DRILL 12.3 MM HOLE INTO DASH PANEL.
  - 1 SEE BATTERY INSTL FOR ADDITIONAL INFORMATION.

- 1G8 GEN-2.8KW ONAN GAS
- 384 GEN 2.5KW ONAN-MICROLITE
- 265 CODES/STANDARDS-CSA/CMVSS
- 1B1 CODES/STANDARDS USA

FOR ELECTRICAL TORQUE SPECIFICATIONS SEE DWG NO. 128783-01-000

FOR ELECTRICAL CALLOUTS SEE DWG NO. 121339-01-000

DESCRIPTION:		1B1 265	
<b>WIRING INSTL-CHASSIS</b>			
SHEET:	ITEM/PART NO.:	REV	
2 OF 3	000209582 / 30101801000		

8 7 6 5 4 3 2 1 09-May-2017

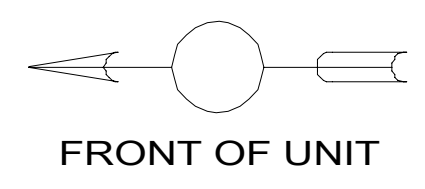
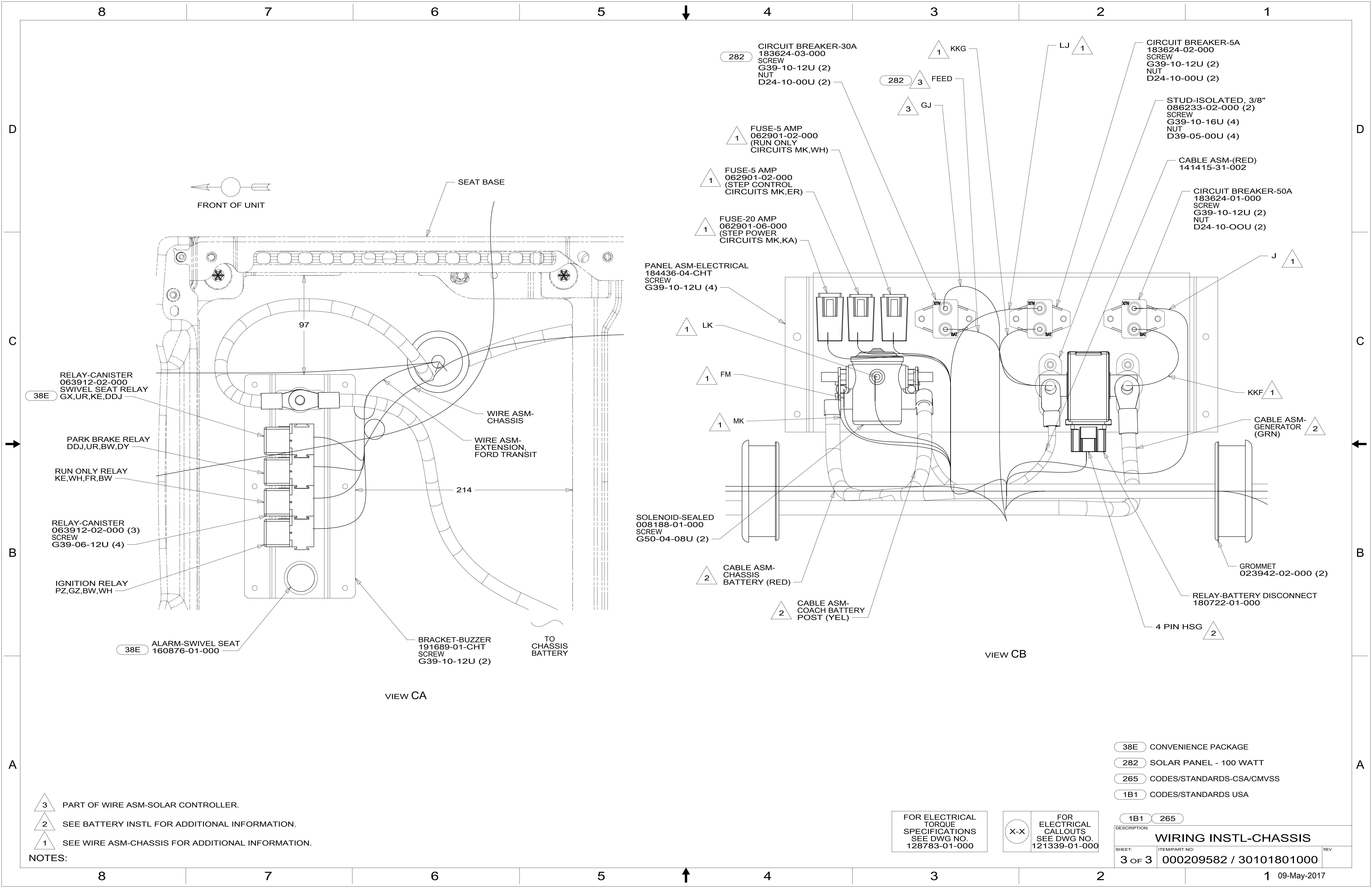

FRONT OF UNIT

SEAT BASE

RELAY-CANISTER  
063912-02-000  
SWIVEL SEAT RELAY  
GX,UR,KE,DDJ

PARK BRAKE RELAY  
DDJ,UR,BW,DY

RUN ONLY RELAY  
KE,WH,FR,BW

RELAY-CANISTER  
063912-02-000 (3)  
SCREW  
G39-06-12U (4)

IGNITION RELAY  
PZ,GZ,BW,WH

ALARM-SWIVEL SEAT  
160876-01-000

WIRE ASM-  
CHASSIS

WIRE ASM-  
EXTENSION,  
FORD TRANSIT

BRACKET-BUZZER  
191689-01-CHT  
SCREW  
G39-10-12U (2)

TO  
CHASSIS  
BATTERY

VIEW CA

PANEL ASM-ELECTRICAL  
184436-04-CHT  
SCREW  
G39-10-12U (4)

SOLENOID-SEALED  
008188-01-000  
SCREW  
G50-04-08U (2)

CABLE ASM-  
CHASSIS  
BATTERY (RED)

CABLE ASM-  
COACH BATTERY  
POST (YEL)

VIEW CB

CIRCUIT BREAKER-30A  
183624-03-000  
SCREW  
G39-10-12U (2)  
NUT  
D24-10-00U (2)

FUSE-5 AMP  
062901-02-000  
(RUN ONLY  
CIRCUITS MK,WH)

FUSE-5 AMP  
062901-02-000  
(STEP CONTROL  
CIRCUITS MK,ER)

FUSE-20 AMP  
062901-06-000  
(STEP POWER  
CIRCUITS MK,KA)

1 KKG

282 3 FEED

3 GJ

CIRCUIT BREAKER-5A  
183624-02-000  
SCREW  
G39-10-12U (2)  
NUT  
D24-10-00U (2)

STUD-ISOLATED, 3/8"  
086233-02-000 (2)  
SCREW  
G39-10-16U (4)  
NUT  
D39-05-00U (4)

CABLE ASM-(RED)  
141415-31-002

CIRCUIT BREAKER-50A  
183624-01-000  
SCREW  
G39-10-12U (2)  
NUT  
D24-10-00U (2)

1 J

1 KKF

CABLE ASM-  
GENERATOR  
(GRN)

GROMMET  
023942-02-000 (2)

RELAY-BATTERY DISCONNECT  
180722-01-000

2 4 PIN HSG

- NOTES:
- 3 PART OF WIRE ASM-SOLAR CONTROLLER.
  - 2 SEE BATTERY INSTL FOR ADDITIONAL INFORMATION.
  - 1 SEE WIRE ASM-CHASSIS FOR ADDITIONAL INFORMATION.

FOR ELECTRICAL  
TORQUE  
SPECIFICATIONS  
SEE DWG NO.  
128783-01-000

FOR  
ELECTRICAL  
CALLOUTS  
SEE DWG NO.  
121339-01-000

- 38E CONVENIENCE PACKAGE
- 282 SOLAR PANEL - 100 WATT
- 265 CODES/STANDARDS-CSA/CMVSS
- 1B1 CODES/STANDARDS USA

DESCRIPTION: <b>WIRING INSTL-CHASSIS</b>	
SHEET: 3 OF 3	ITEM/PART NO: 000209582 / 30101801000
REV 09-May-2017	