

REV	ZONE	REVISION RECORD	DATE	DFTR-ORIG
A	---	INITIAL RELEASE	11/04/15	3650
B	---	SHT 2 A-3 TU-9/100 WAS 150, TU-10/100 WAS 165	1/25/16	7381
C	---	CHG SHOWER LOC. DIM. SHT4	3-7-16	1600-3508
D	---	ADD LENGTH SHT3	3-31-16	1600-3508
E	---	CHG RISERS IN TRACK SHT2	4-27-16	1600-3508
F	SHT2	NEW FILTER	12-21-16	0626-1600
G	---	CHG NIPPLE SHT4	1-17-17	1600-6073

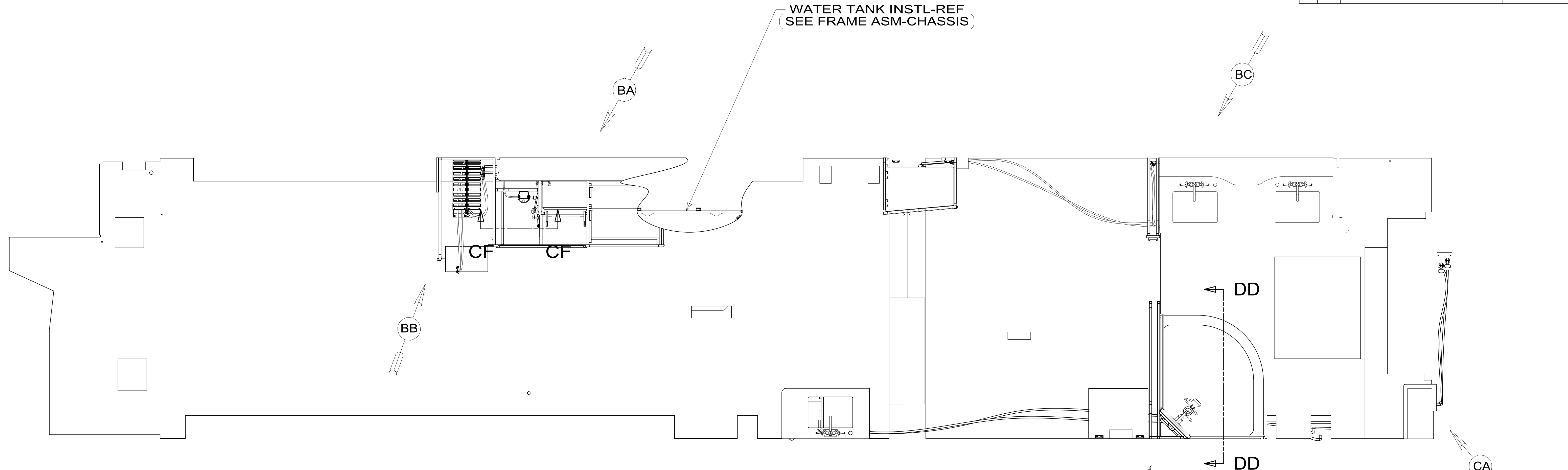

- 14. FOR INSTALLATION USE SILICON-ADHESIVE 131264-05-CHT. APPLY ON TOP OF PLATE, PLACE COVER ON, AND PUT ADHESIVE AROUND COVER.
- 13. INSTALL FAUCET WITHOUT BASEPLATE.
- 12. SEE STYLING SHEETS.
- 11. REQUIRES 5 GALLONS OF 182955-01-000 ANTIFREEZE FOR WINTERIZATION.
- 10. VALVE MUST REMAIN OPEN AFTER WATER TEST.
- 9. FLUSHING SYSTEM REQUIRES 125697-06-000 INSTRUCTION SHEET.
- 8. ALL CRIMP FITTINGS TO PEX TUBING REQUIRE 1/2" CLAMP 140171-03-000.
- 7. ALL CRIMP FITTINGS TO PEX TUBING REQUIRE 5/8" CLAMP 140171-04-000.
- 6. LABEL HOT AND COLD SUPPLY TUBES AND TAPE FITTING TO TUBE BEFORE CABINET SET TO PREVENT MOVEMENT.
- 5. ADD PIPE WRAP (LADDER SCRAP 110157-02-000) INSULATION.
- 4. ADD TEFLON TAPE 010405-02-000.
- 3. ALL TUBING TO BE SECURED AT 1200 INTERVALS MAXIMUM WITH CLAMP 010495-01-000 AND SCREW 000G67-10-12U OR EQUIVALENT.
- 2. TUBING TO BE INSTALLED WITH SUFFICIENT SLOPE TO PROVIDE DRAINAGE TO NEAREST VALVE.
- 1. PLASTIC FITTINGS TO BE SEALED WITH SEALANT 084456-01-000.

X-X

FOR WATER CALLOUTS SEE DWG NO. 000209446 / 303369-01-000

WINNEBAGO[®]
COPYRIGHT 2016 WINNEBAGO INDUSTRIES, INC.

DSNR:		ALL DIMENSIONS ARE IN MILLIMETERS	
DFTR:			
UNSPECIFIED TOLERANCES:		MATERIAL:	
WHOLE DIM (X)	3		
ONE-PLACE (X.X)	1.5		
TWO-PLACE (X.XX)	0.50		
ANGLE	1°		
REFER TO ES0018 FOR FASTENER TIGHTENING GUIDELINES		WEIGHT: (LBS)	FIRST USED: (REF)
			16 R45RL
DESCRIPTION:			
WATER SYSTEM INSTL			
SHEET:	ITEM/PART NO:	REV	
1 OF 5	000209163 / 30237801000		
REF:		1 01-Feb-2017	

NOTES:

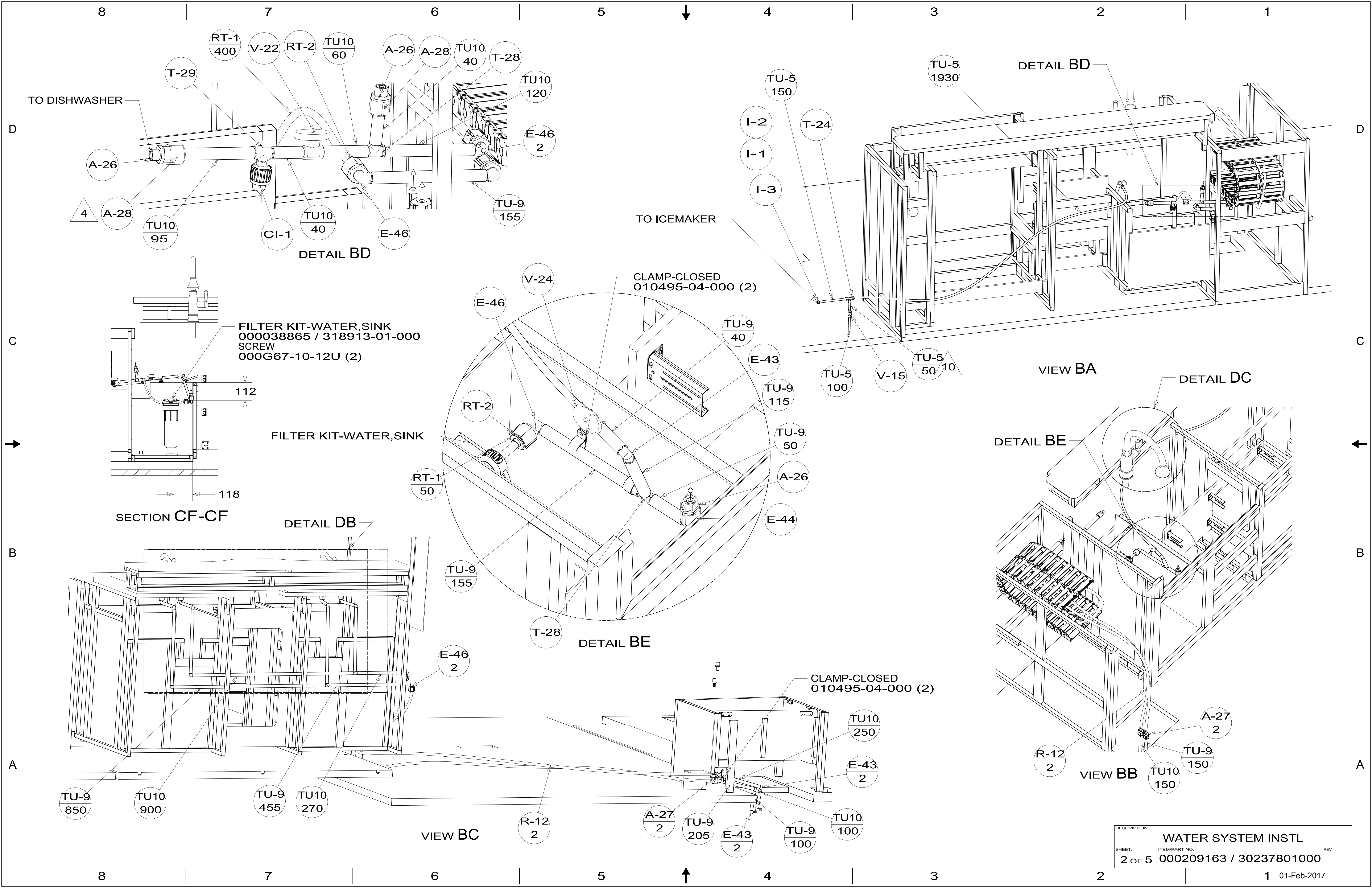

TO DISHWASHER

TO ICEMAKER

DETAIL BD

DETAIL BD

CLAMP-CLOSED
010495-04-000 (2)

FILTER KIT-WATER,SINK
000038865 / 318913-01-000
SCREW
000G67-10-12U (2)

SECTION CF-CF

DETAIL DB

DETAIL BE

VIEW BA

DETAIL DC

DETAIL BE

VIEW BB

VIEW BC

CLAMP-CLOSED
010495-04-000 (2)

DESCRIPTION: WATER SYSTEM INSTL		
SHEET: 2 OF 5	ITEM/PART NO: 000209163 / 30237801000	REV

1 01-Feb-2017

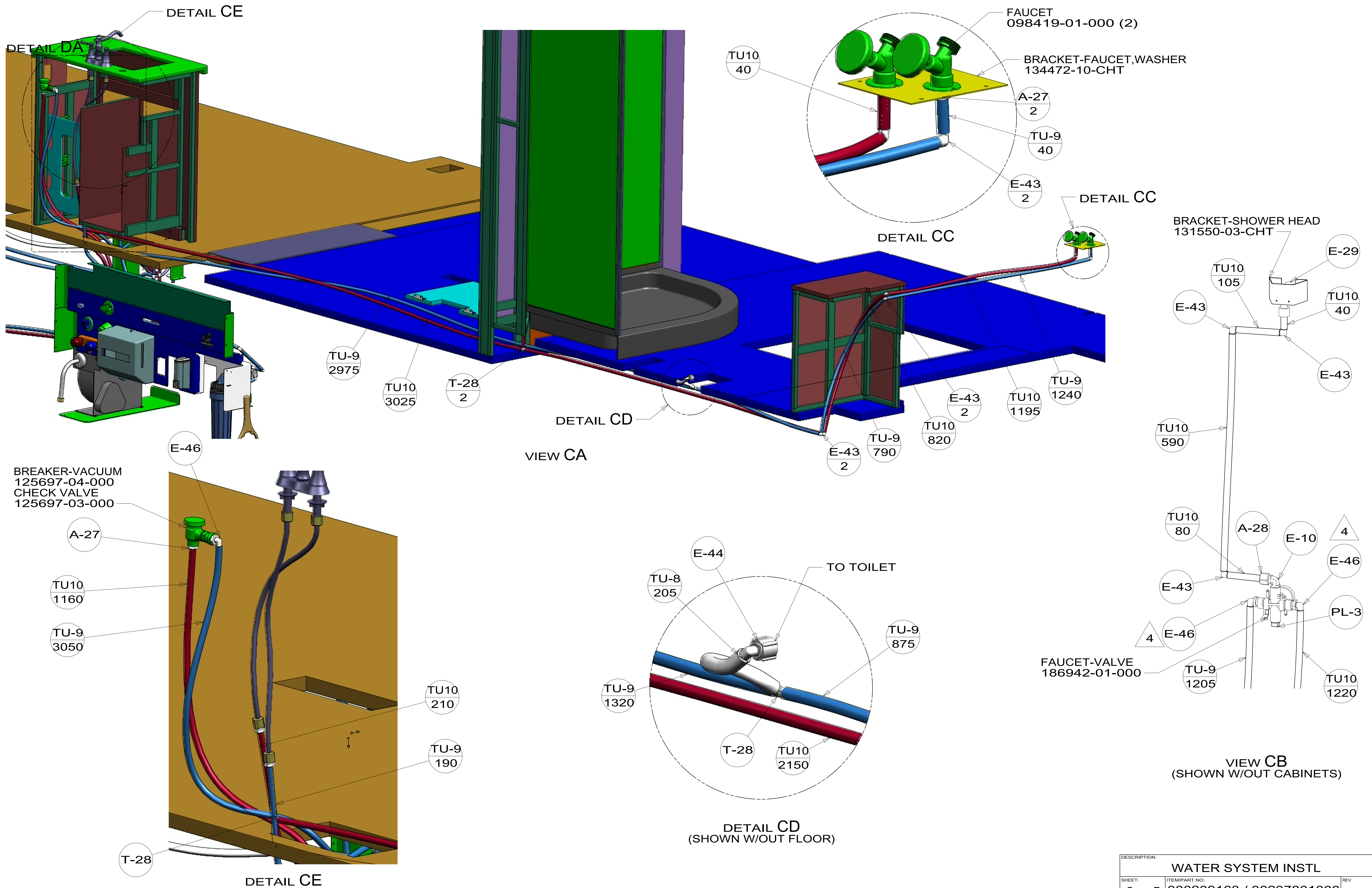

DESCRIPTION:		
WATER SYSTEM INSTL		
SHEET:	ITEM/PART NO.:	REV
3 OF 5	000209163 / 30237801000	
		1 01-Feb-2017

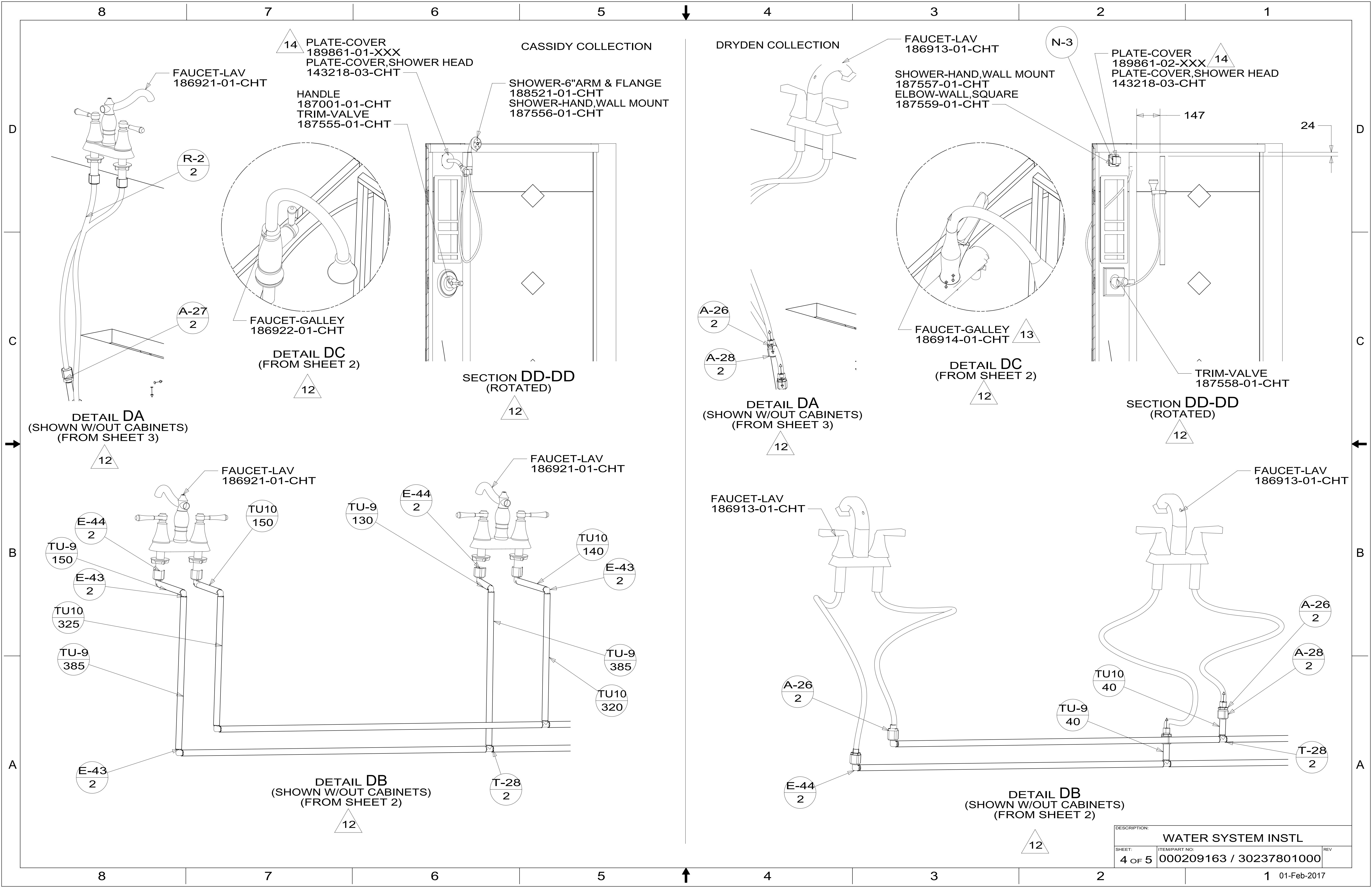

DESCRIPTION:		
WATER SYSTEM INSTL		
SHEET:	ITEM/PART NO.:	REV
4 OF 5	000209163 / 30237801000	

