

- 6 ROUTE CABLE FROM RADIO TO PASSENGER'S STEPWELL AREA, UP WINGWALL, THROUGH SLEEPER BOARD ASM, UNDER TRIM TO ANTENNA PLATE ON ROOF.
- 5 MOUNT ANTENNA AND PLATE SUCH THAT BASE IS SQUARE WITH ROOF AND DIRECTLY OVER HOLE IN ROOF. SEAL BOTH HOLE IN ROOF AND ANTENNA BASE AT SCREWS.
- 4 SUPPLIED WITH CHASSIS. USE SHORTEST SUPPLIED ANTENNA.
- 3 ROUTE CABLE TO DASH RADIO.
- 2 WIRING IS ROUTED DIFFERENTLY FOR EACH UNIT FROM THIS POINT REARWARD.
- 1 REAR MONITOR CAMERA CABLE IS PART OF WIRE ASM-CHASSIS AND RUNS ALONG LEFT FRAME RAIL.

NOTES:

ANTENNA-SATELLITE RADIO  
181908-02-000  
PLATE-SATELLITE RADIO  
177256-04-CHT  
SCREW  
G-11-08-08U (4)  
SEAL

70C  
643

CABLE-MONITOR 1 3

WIRE ASM-MONITOR, 15'  
(REF) 283

70C  
643 CABLE-ANTENNA, SATELLITE  
(SUPPLIED WITH ANTENNA)

283 WIRE ASM-MONITOR  
(REF)

4 ANTENNA-RADIO

HOLE IN FLOOR

- 643 RENTAL-MILES DIXON
- 70C RADIO - SATELLITE
- 283 MIRRORS-UPGRADE W/CAMERA
- 265 CODES/STANDARDS-CSA/CMVSS
- 1B1 CODES/STANDARDS USA

1B1 265



DSNR:		ALL DIMENSIONS ARE IN MILLIMETERS	
DIFFR:		MATERIAL:	
UNSPECIFIED TOLERANCES:			
WHOLE DIM (X)	: 3		
ONE-PLACE (X.X)	: 1.5		
TWO-PLACE (X.XX)	: 0.50		
ANGLE	: 1°		
REFER TO ES0018 FOR FASTENER TIGHTENING GUIDELINES		WEIGHT: (LBS)	FIRST USED:
			16 325B

FOR ELECTRICAL TORQUE SPECIFICATIONS SEE DWG NO. 128783-01-000

FOR ELECTRICAL CALLOUTS SEE DWG NO. 121339-01-000

DESCRIPTION: <b>RADIO/MONITOR INSTL</b>		
SHEET: 1 OF 5	ITEM/PART NO: 000208692 / 30073901000	REV:
REF:		1 24-Oct-2016

8 7 6 5 4 3 2 1

D  
C  
B  
A

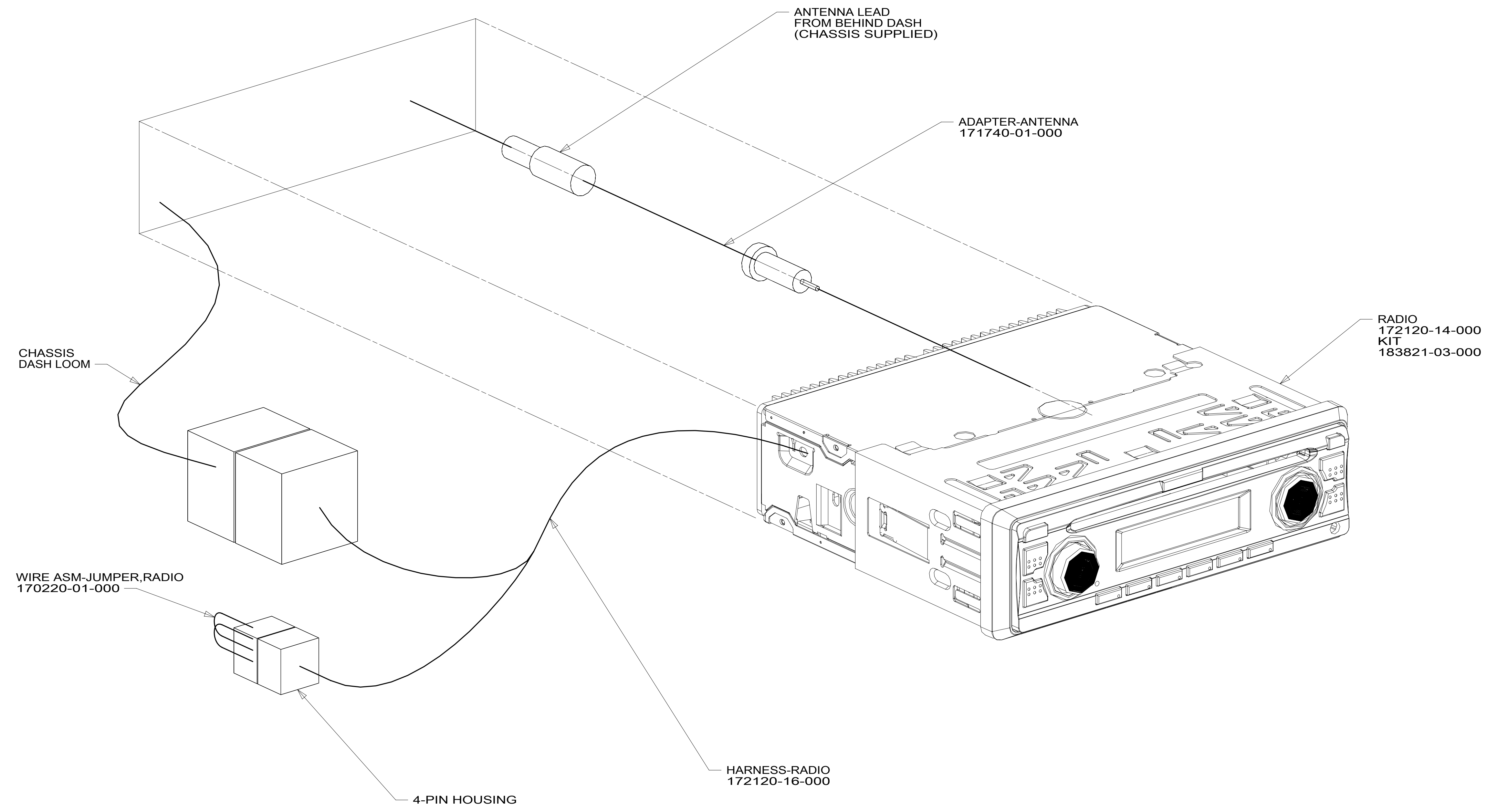

- 19V RADIO-AM/FM STEREO CD PLAYER
- 265 CODES/STANDARDS-CSA/CMVSS
- 1B1 CODES/STANDARDS USA

FOR ELECTRICAL TORQUE SPECIFICATIONS SEE DWG NO. 128783-01-000

FOR ELECTRICAL CALLOUTS SEE DWG NO. 121339-01-000

DESCRIPTION:	1B1 265 19V	
<b>RADIO/MONITOR INSTL</b>		
SHEET:	ITEM/PART NO:	REV
2 OF 5	000208692 / 30073901000	

8 7 6 5 4 3 2 1 24-Oct-2016

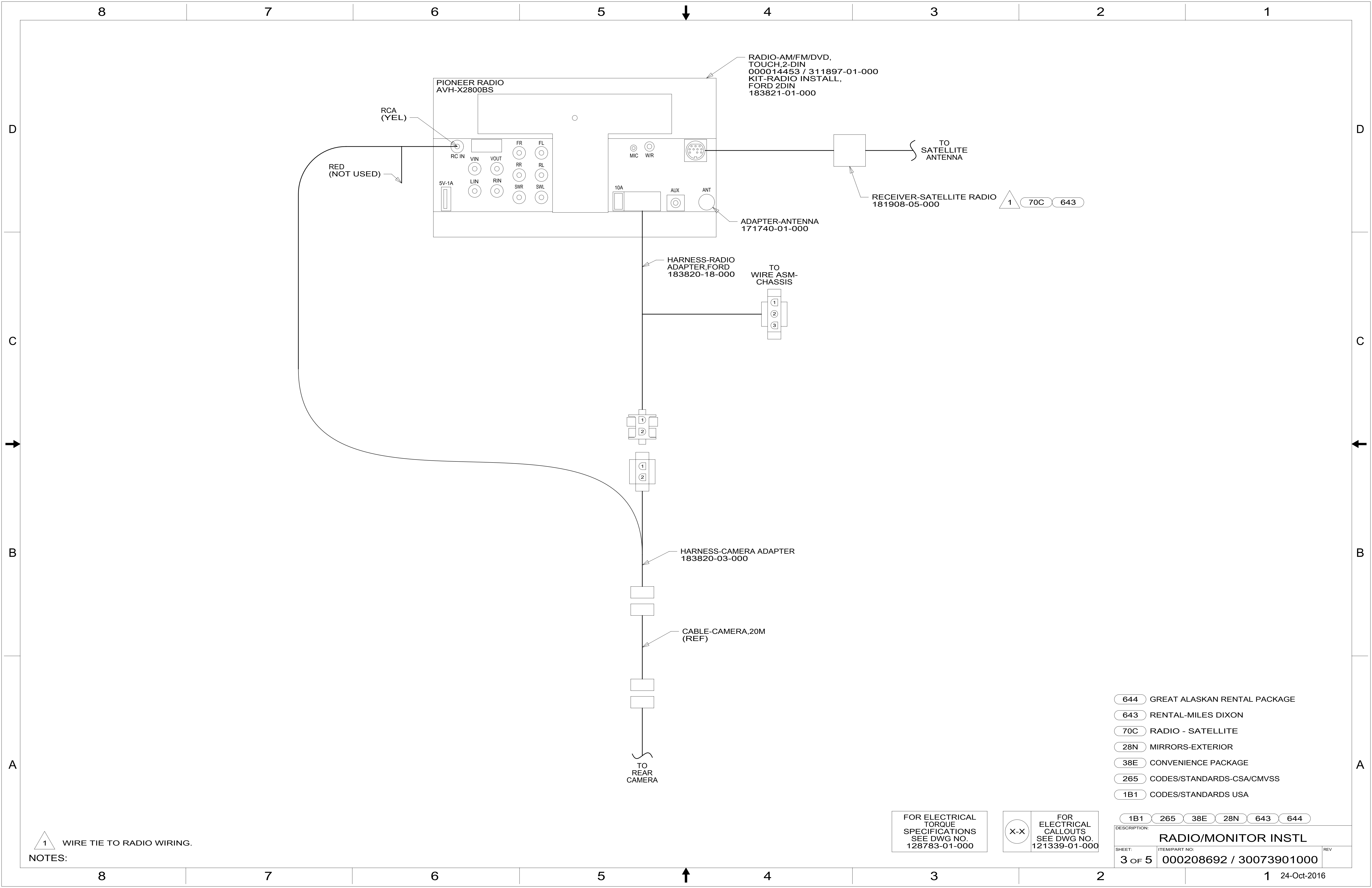

RADIO-AM/FM/DVD,  
TOUCH,2-DIN  
000014453 / 311897-01-000  
KIT-RADIO INSTALL,  
FORD 2DIN  
183821-01-000

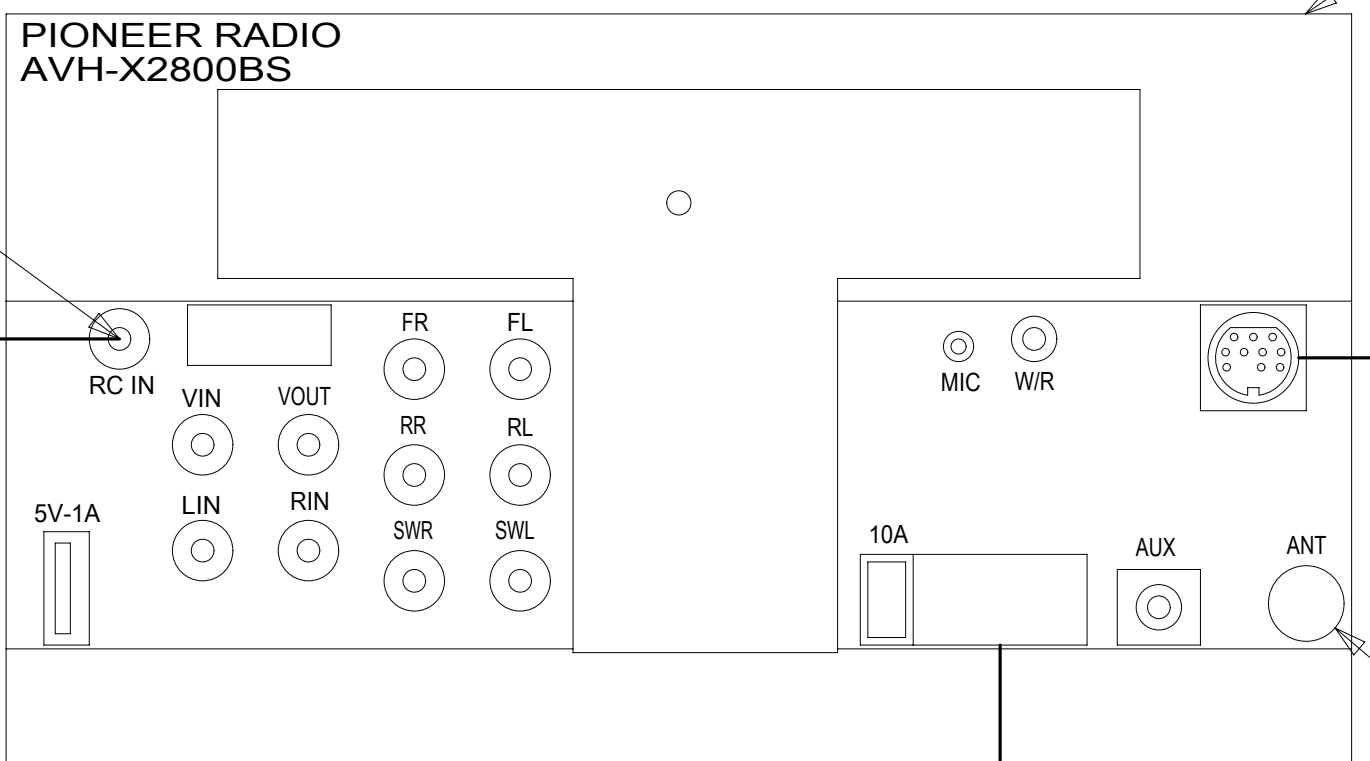

TO SATELLITE  
ANTENNA

RECEIVER-SATELLITE RADIO  
181908-05-000

1 70C 643

ADAPTER-ANTENNA  
171740-01-000

HARNESS-RADIO  
ADAPTER,FORD  
183820-18-000

TO  
WIRE ASM-  
CHASSIS

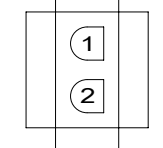
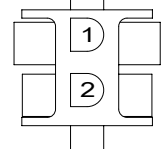
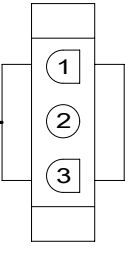

HARNESS-CAMERA ADAPTER  
183820-03-000

CABLE-CAMERA,20M  
(REF)

TO  
REAR  
CAMERA

RCA  
(YEL)

RED  
(NOT USED)

- 644 GREAT ALASKAN RENTAL PACKAGE
- 643 RENTAL-MILES DIXON
- 70C RADIO - SATELLITE
- 28N MIRRORS-EXTERIOR
- 38E CONVENIENCE PACKAGE
- 265 CODES/STANDARDS-CSA/CMVSS
- 1B1 CODES/STANDARDS USA

1B1 265 38E 28N 643 644

FOR ELECTRICAL  
TORQUE  
SPECIFICATIONS  
SEE DWG NO.  
128783-01-000

FOR ELECTRICAL  
CALLOUTS  
SEE DWG NO.  
121339-01-000

DESCRIPTION: <b>RADIO/MONITOR INSTL</b>		
SHEET: <b>3 OF 5</b>	ITEM/PART NO: <b>000208692 / 30073901000</b>	REV

NOTES:  
1 WIRE TIE TO RADIO WIRING.

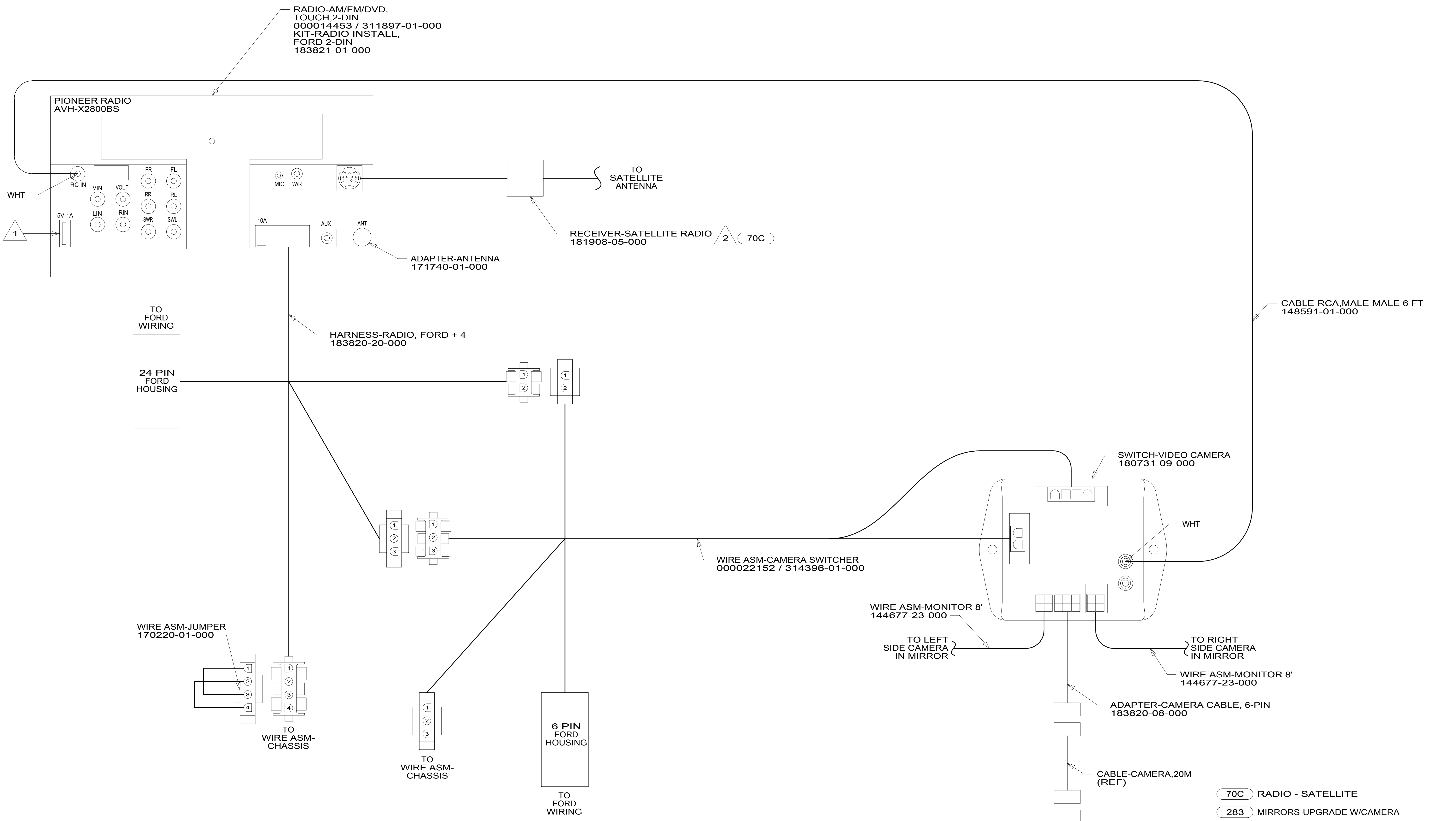

RADIO-AM/FM/DVD,  
TOUCH,2-DIN  
000014453 / 311897-01-000  
KIT-RADIO INSTALL,  
FORD 2-DIN  
183821-01-000

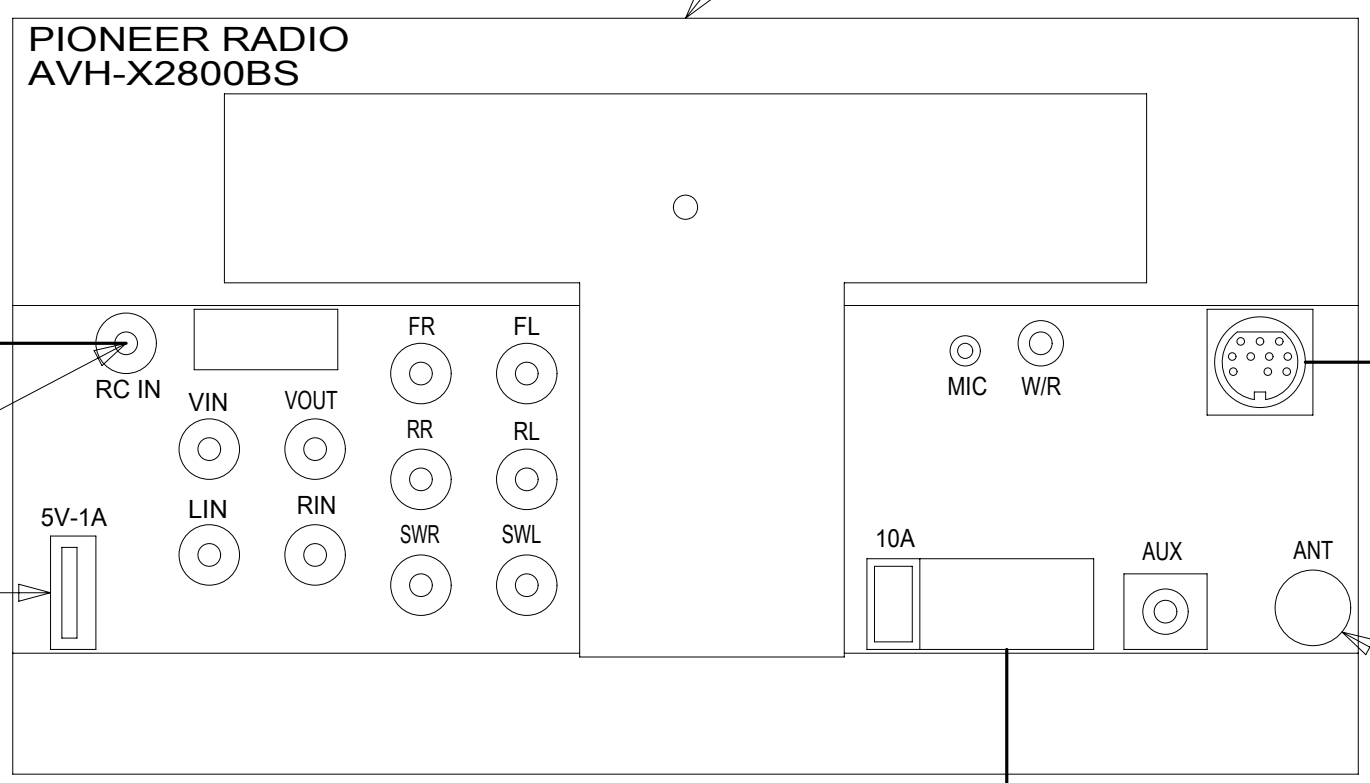

1

2 70C

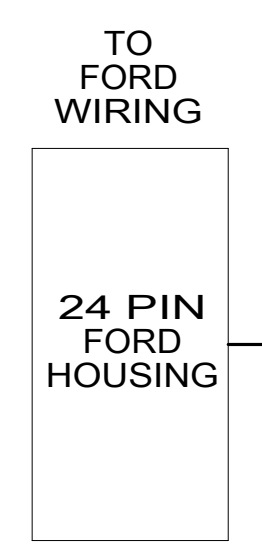

WIRE ASM-JUMPER  
170220-01-000

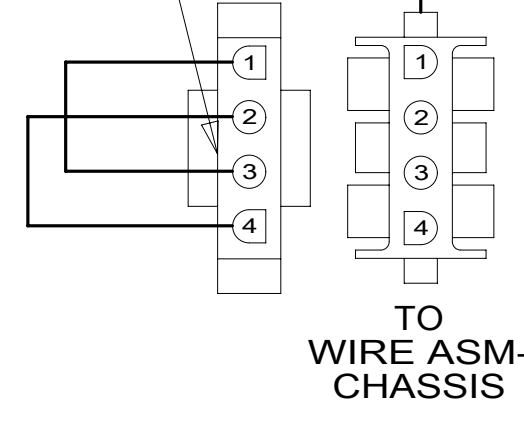

TO WIRE ASM-  
CHASSIS

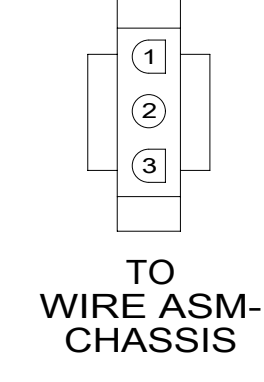

TO WIRE ASM-  
CHASSIS

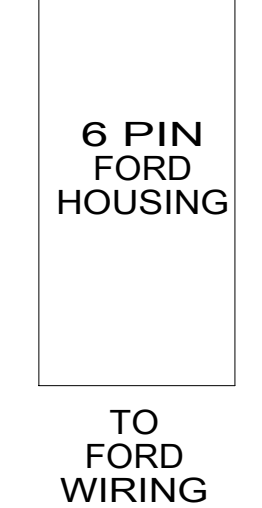

TO FORD  
WIRING

WIRE ASM-MONITOR 8'  
144677-23-000

TO LEFT  
SIDE CAMERA  
IN MIRROR

WIRE ASM-MONITOR 8'  
144677-23-000

TO RIGHT  
SIDE CAMERA  
IN MIRROR

ADAPTER-CAMERA CABLE, 6-PIN  
183820-08-000

CABLE-CAMERA,20M  
(REF)

TO REAR  
CAMERA

2 WIRE TIE TO RADIO WIRING.

1 PLUG USB CABLE SUPPLIED WITH RADIO INTO LEAD ON BACK OF RADIO MARKED 'USB'. ROUTE CABLE TO THE LEFT OF RADIO. WIRE TIE EXCESS CABLE UNDER DASH IN THE AREA LEFT OF THE RADIO. LEAVE 200 MM OF CABLE IN THE MOTOR COVER BEVERAGE TRAY. MAKE SURE CABLE DOES NOT GET PINCHED BY MOTOR COVER.

NOTES:

FOR ELECTRICAL  
TORQUE  
SPECIFICATIONS  
SEE DWG NO.  
128783-01-000

FOR ELECTRICAL  
CALLOUTS  
SEE DWG NO.  
121339-01-000

- 70C RADIO - SATELLITE
- 283 MIRRORS-UPGRADE W/CAMERA
- 38E CONVENIENCE PACKAGE
- 265 CODES/STANDARDS-CSA/CMVSS
- 1B1 CODES/STANDARDS USA

1B1 265 38E 283

DESCRIPTION: <b>RADIO/MONITOR INSTL</b>		
SHEET: 4 OF 5	ITEM/PART NO: 000208692 / 30073901000	REV

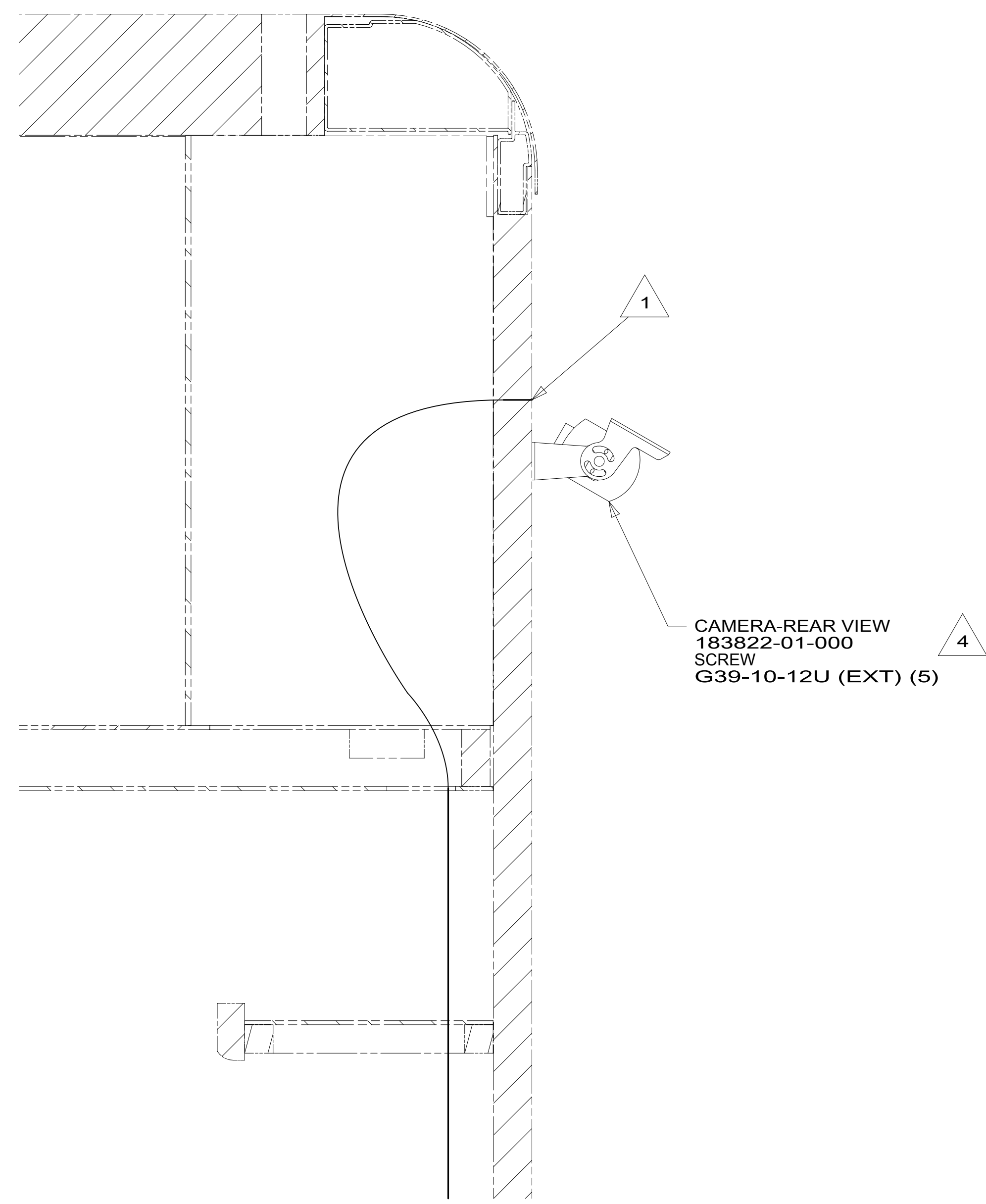
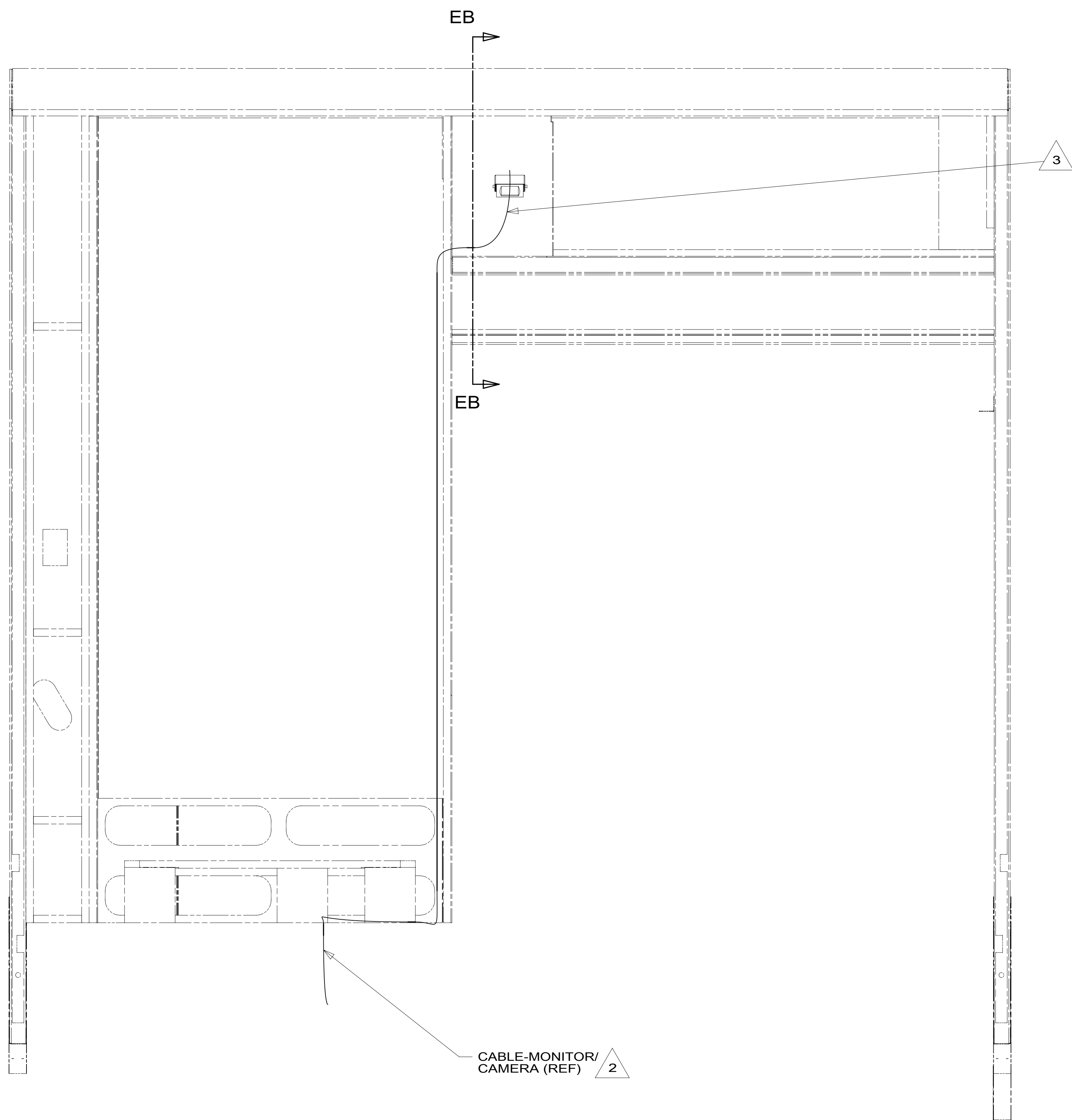

SECTION EB-EB 38E 643

- NOTES:
- 4 ADJUST CAMERA AFTER MOUNTING SO BACKWALL IS JUST VISIBLE ON BOTTOM OF THE SCREEN.
  - 3 LEAVE CAMERA CABLE IN BOTTOM OF OVHD CABT WITHOUT 38E
  - 2 REAR MONITOR CABLE IS PART OF THE WIRE ASM-CHASSIS.
  - 1 CABLE ROUTED THRU BACKWALL.

- 643 RENTAL-MILES DIXON
- 38E CONVENIENCE PACKAGE
- 265 CODES/STANDARDS-CSA/CMVSS
- 1B1 CODES/STANDARDS USA

FOR ELECTRICAL TORQUE SPECIFICATIONS SEE DWG NO. 128783-01-000

FOR ELECTRICAL CALLOUTS SEE DWG NO. 121339-01-000

DESCRIPTION:		<b>RADIO/MONITOR INSTL</b>	
SHEET:	ITEM/PART NO.:	REV	
5 OF 5	000208692 / 30073901000		