

SWITCH-WATER PUMP
108357-15-CHT
ACTUATOR
108356-03-CHT
CIRCUITS
AG,JA,AF,JS,JY

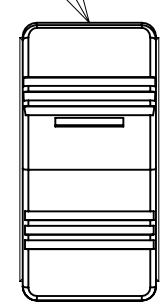
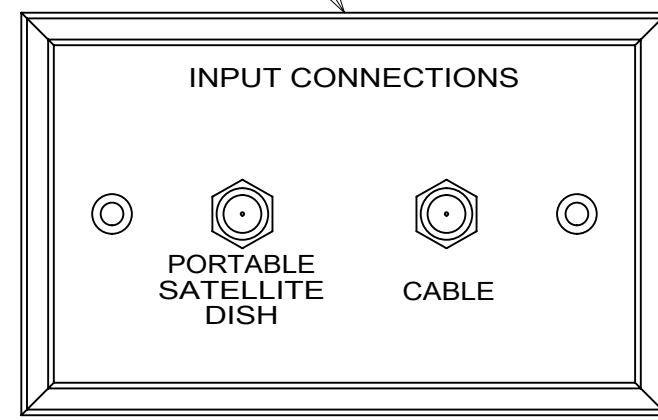

PLATE-WALL,DUAL COAX
149557-03-CHT
SCREW
G39-08-08U (2)



VIEW AA

TO COMPT LAMP

LO1-3
2

COAX (RED)
TO CABLE INPUT
COAX (GLD)
TO PORTABLE
SATELLITE
DISH INPUT

TO SLIDEOUT

- 4 WIRE PASSES THROUGH FLOOR IN THIS AREA.
- 3 PLACE CROSS LOCATOR ON SENSORS OVER DIMPLES ON TANK.

2. ROUTE TANK SENSOR WIRES SO THEY DO NOT PASS OVER SENSORS. USE WIRE TIE MOUNT 155366-01-000 AND WIRE TIE 8343-01-000 AS NEEDED. TANK SURFACE MUST BE CLEANED USING ISOPROPYL ALCOHOL AND PRIMED WITH PRIMER 94.

1. AT MINIMUM ALL WIRES TO BE SUPPORTED AND SECURED PER CODE REQUIREMENTS. USE CLAMP 10495 OR 10497 OR WIRE TIE 8343 OR 108046 AND SCREW G67-XX-XXX OR G56-XX-XXX AS APPROPRIATE FOR INSTALLATION.

NOTES:

CONTROL-SLIDEOUT,IN-WALL
189400-01-000
SCREW
G11-10-12U (4)
DETAIL GA

2 PIN HOUSING
TO WIRE ASM-AUX
HOLDING TANK

3 WIRE ASM-AUX
HOLDING TANK
151316-03-000

TO COMPT LAMP

401 INVERTER CONTROL CABLE
TO REMOTE PANEL

3 WIRE ASM-MAIN
HOLDING TANK
151317-02-000

2 PIN HOUSING
TO WIRE ASM-MAIN
HOLDING TANK

4

PANEL-RECEPTACLE
151376-02-CHT
ADAPTOR
82134-01-000
NUT
82136-01-000
LABEL
157486-01-CHT
SCREW
G67-10-12B (4)

WIRE ASM-TANK,WATER
151317-01-000

CONTROL-SLIDEOUT,IN-WALL
189400-01-000
SCREW
G11-10-12U (4)
DETAIL GB

2 PIN HOUSING
TO WATER PUMP

INVERTER CONTROL CABLE
TO INVERTER FROM INVERTER
CONTROL MODULE

2 PIN HOUSING
TO WIRE ASM-TANK,WATER

WIRE ASM-COACH
193114-01-000
193115-01-000

12D
078

3

401

FOR ELECTRICAL
TORQUE
SPECIFICATIONS
SEE DWG NO.
128783-01-000

FOR ELECTRICAL
CALLOUTS
SEE DWG NO.
121339-01-000

- 12D ELECTRICAL SYSTEM 30 AMP
- 078 ALL WEATHER UPGRADE PACKAGE
- 401 INVERTER-DC/AC, 1000 WATT
- 265 CODES/STANDARDS-CSA/CMVSS
- 1B1 CODES/STANDARDS USA

1B1 265



DSNR:		ALL DIMENSIONS ARE IN MILLIMETERS	
DIFFR:		MATERIAL:	
UNSPECIFIED TOLERANCES:			
WHOLE DIM (X)	: 3		
ONE-PLACE (X.X)	: 1.5		
TWO-PLACE (X.XX)	: 0.50		
ANGLE	: 1°		
REFER TO ES0018 FOR FASTENER TIGHTENING GUIDELINES		WEIGHT: (LBS)	FIRST USED:
			16 E30T
DESCRIPTION: WIRING INSTL-BODY, 12V			
SHEET:	ITEM/PART NO.:	REV:	
1 OF 7	000201106 / 30168401000		

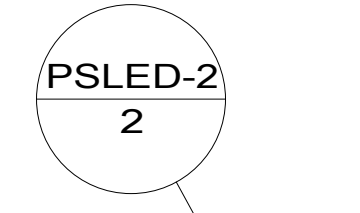
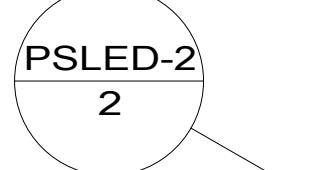
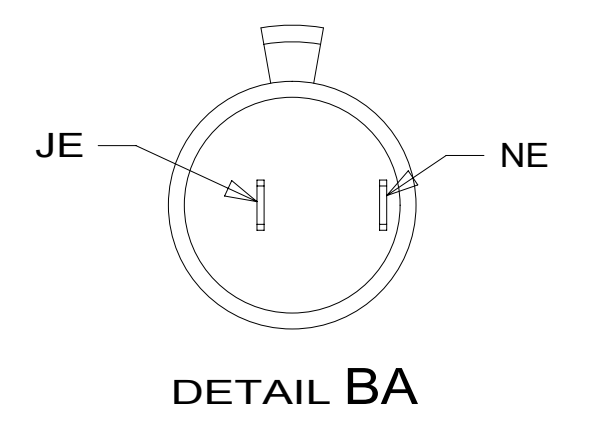
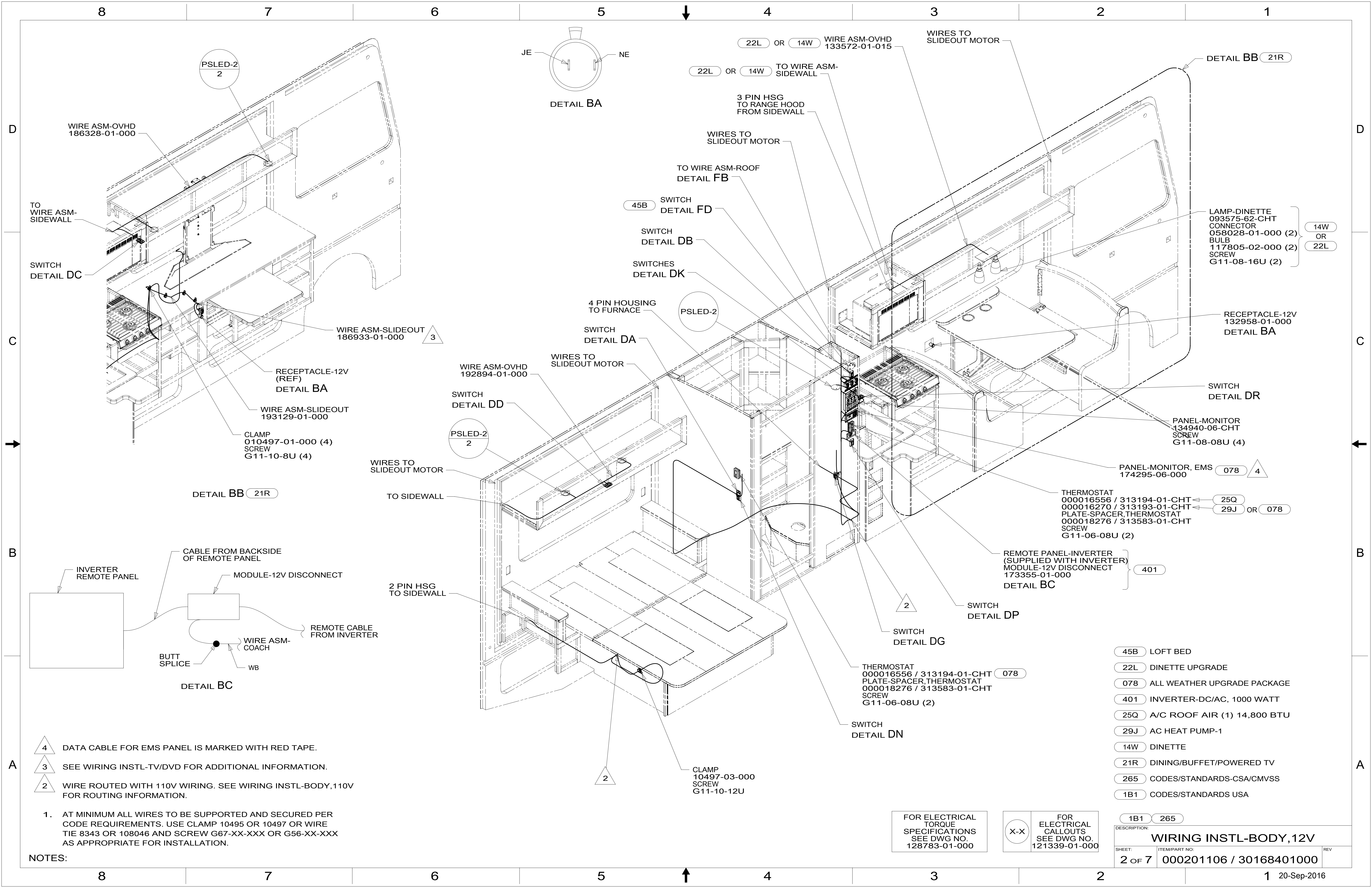

- ▲ 4 DATA CABLE FOR EMS PANEL IS MARKED WITH RED TAPE.
 ▲ 3 SEE WIRING INSTL-TV/DVD FOR ADDITIONAL INFORMATION.
 ▲ 2 WIRE ROUTED WITH 110V WIRING. SEE WIRING INSTL-BODY, 110V FOR ROUTING INFORMATION.

1. AT MINIMUM ALL WIRES TO BE SUPPORTED AND SECURED PER CODE REQUIREMENTS. USE CLAMP 10495 OR 10497 OR WIRE TIE 8343 OR 108046 AND SCREW G67-XX-XXX OR G56-XX-XXX AS APPROPRIATE FOR INSTALLATION.

NOTES:

FOR ELECTRICAL TORQUE SPECIFICATIONS SEE DWG NO. 128783-01-000

FOR ELECTRICAL CALLOUTS SEE DWG NO. 121339-01-000

- 45B LOFT BED
- 22L DINETTE UPGRADE
- 078 ALL WEATHER UPGRADE PACKAGE
- 401 INVERTER-DC/AC, 1000 WATT
- 25Q A/C ROOF AIR (1) 14,800 BTU
- 29J AC HEAT PUMP-1
- 14W DINETTE
- 21R DINING/BUFFET/POWERED TV
- 265 CODES/STANDARDS-CSA/CMVSS
- 1B1 CODES/STANDARDS USA

DESCRIPTION:		1B1 265	
WIRING INSTL-BODY, 12V			
SHEET:	ITEM/PART NO.:	REV:	
2 OF 7	000201106 / 30168401000		

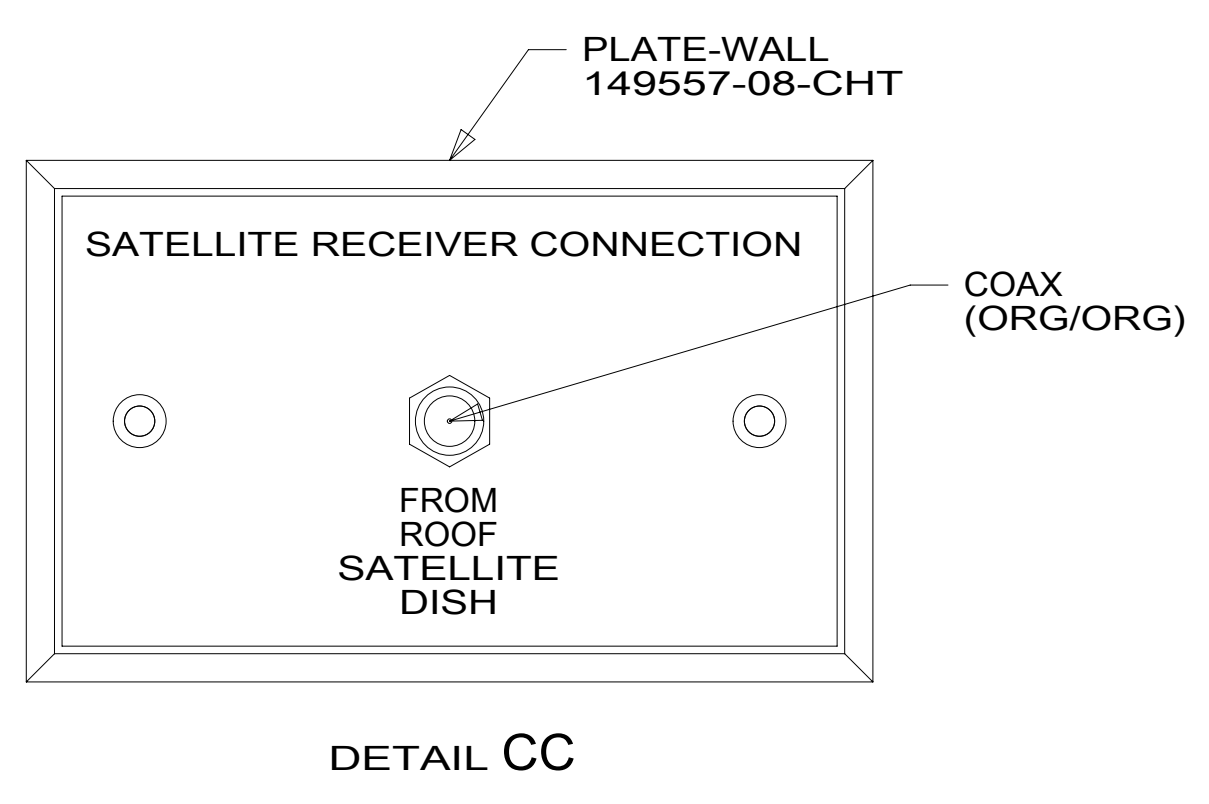
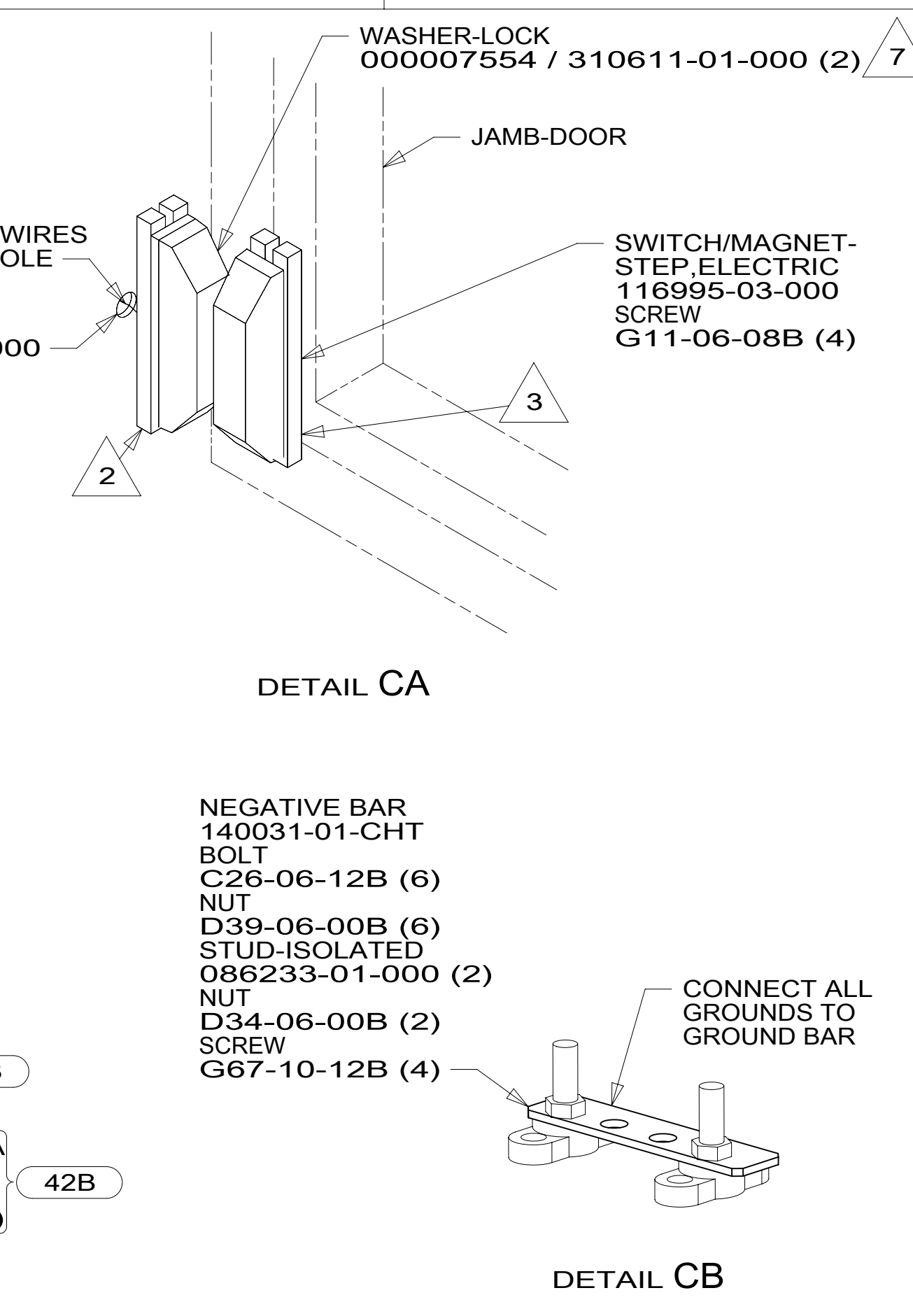
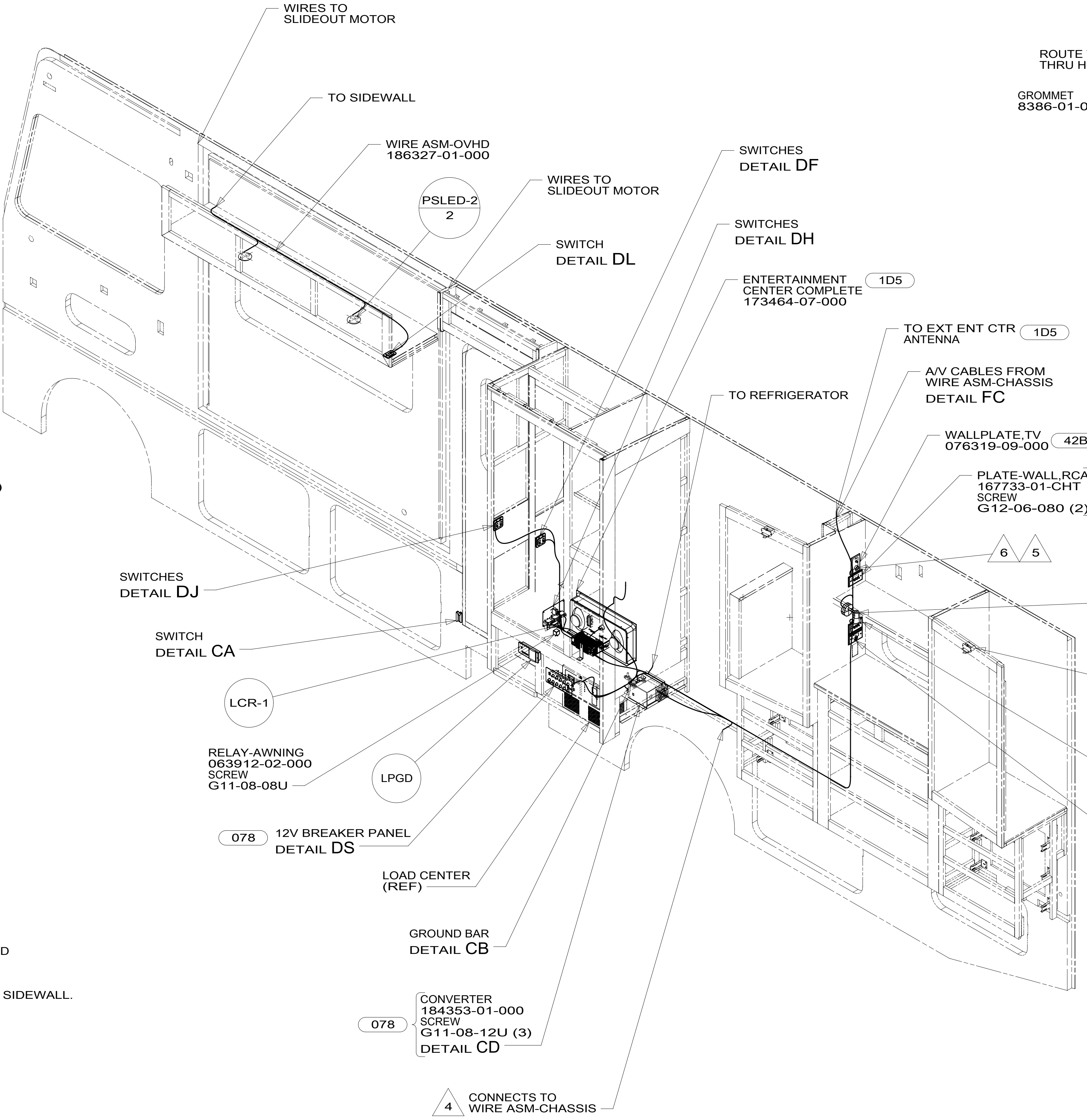
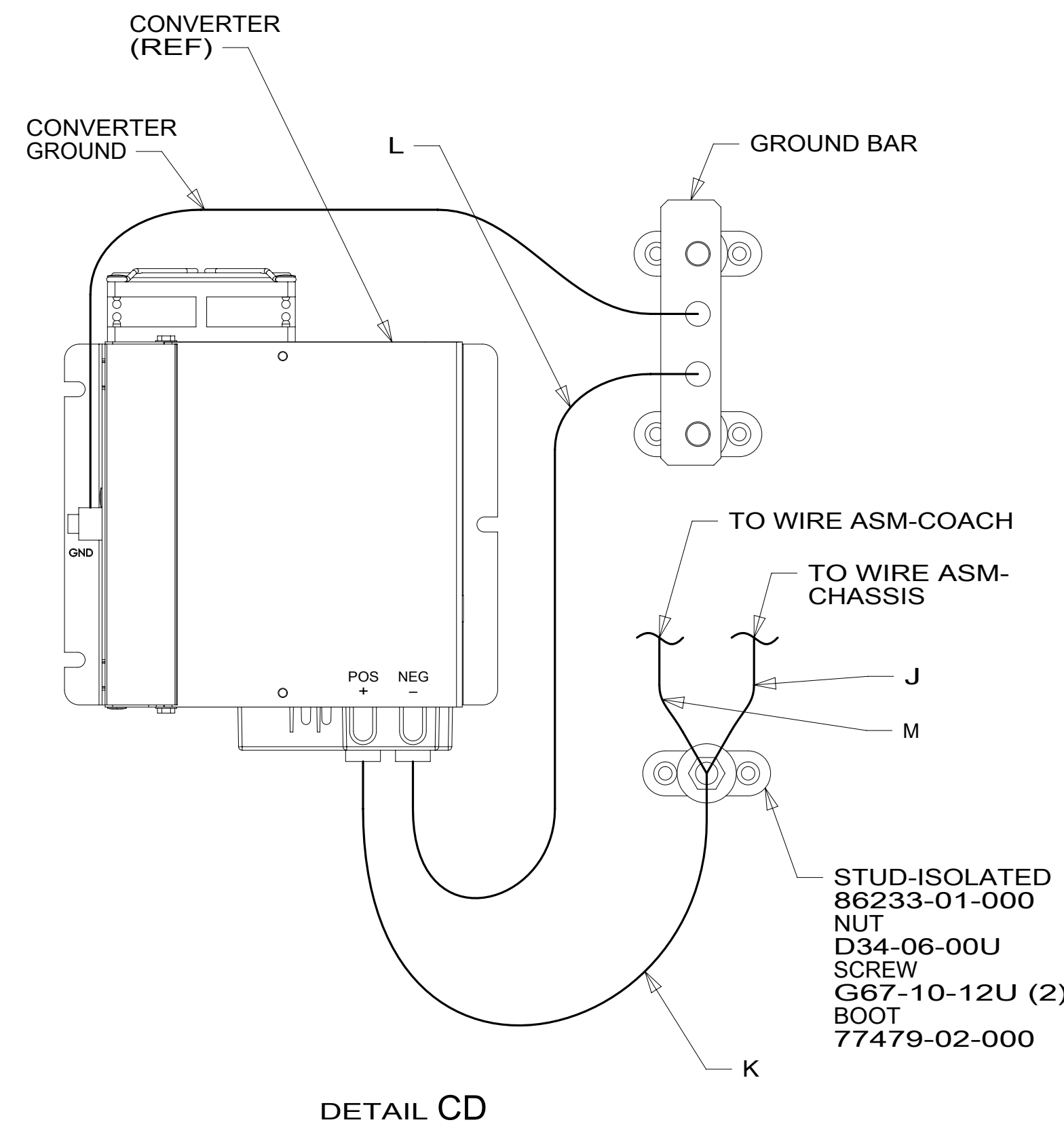
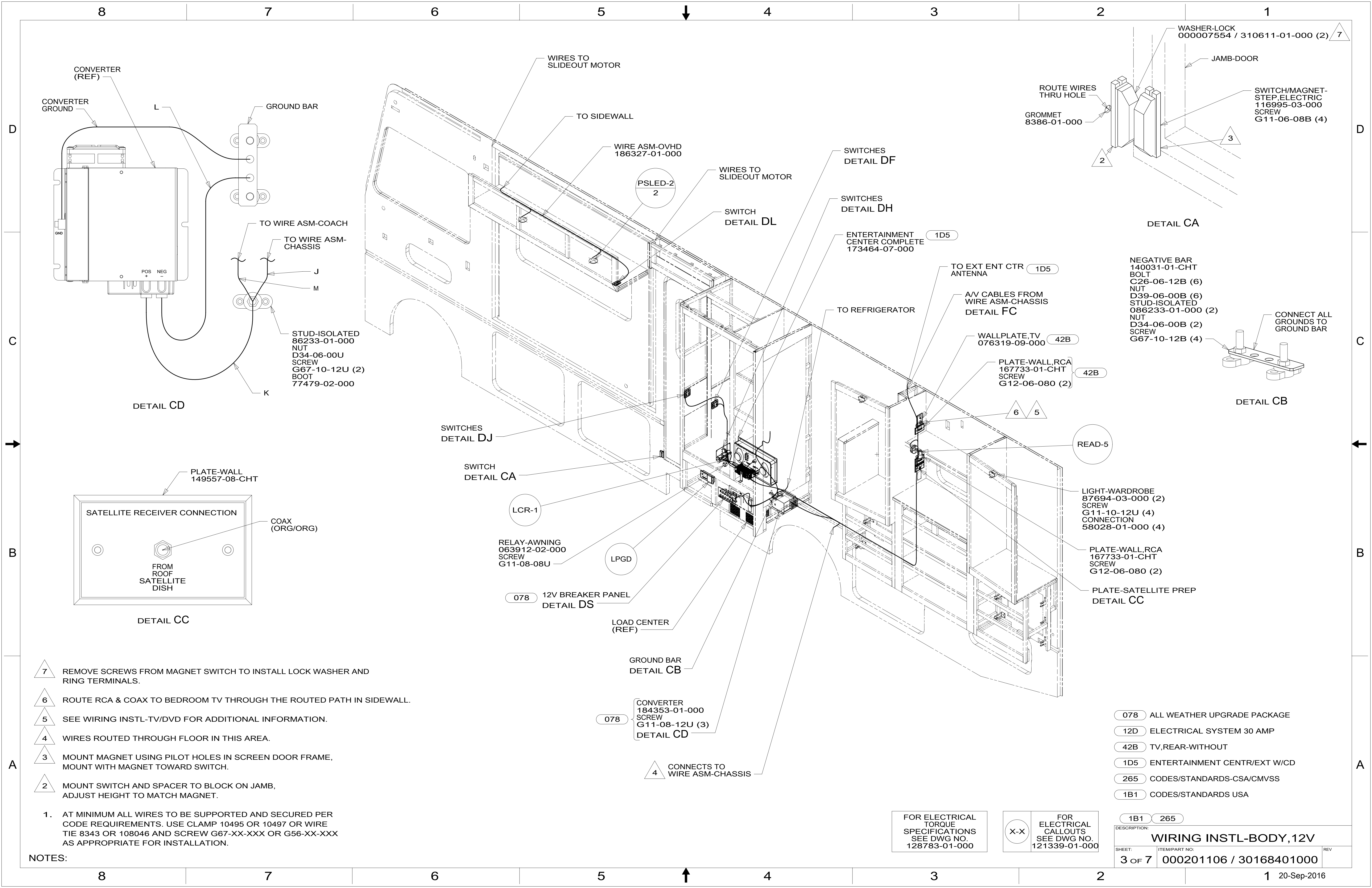

- 7 REMOVE SCREWS FROM MAGNET SWITCH TO INSTALL LOCK WASHER AND RING TERMINALS.
- 6 ROUTE RCA & COAX TO BEDROOM TV THROUGH THE ROUTED PATH IN SIDEWALL.
- 5 SEE WIRING INSTL-TV/DVD FOR ADDITIONAL INFORMATION.
- 4 WIRES ROUTED THROUGH FLOOR IN THIS AREA.
- 3 MOUNT MAGNET USING PILOT HOLES IN SCREEN DOOR FRAME, MOUNT WITH MAGNET TOWARD SWITCH.
- 2 MOUNT SWITCH AND SPACER TO BLOCK ON JAMB, ADJUST HEIGHT TO MATCH MAGNET.

1. AT MINIMUM ALL WIRES TO BE SUPPORTED AND SECURED PER CODE REQUIREMENTS. USE CLAMP 10495 OR 10497 OR WIRE TIE 8343 OR 108046 AND SCREW G67-XX-XXX OR G56-XX-XXX AS APPROPRIATE FOR INSTALLATION.

NOTES:

FOR ELECTRICAL TORQUE SPECIFICATIONS SEE DWG NO. 128783-01-000

FOR ELECTRICAL CALLOUTS SEE DWG NO. 121339-01-000

- 078 ALL WEATHER UPGRADE PACKAGE
- 12D ELECTRICAL SYSTEM 30 AMP
- 42B TV, REAR-WITHOUT
- 1D5 ENTERTAINMENT CENTR/EXT W/CD
- 265 CODES/STANDARDS-CSA/CMVSS
- 1B1 CODES/STANDARDS USA

DESCRIPTION: WIRING INSTL-BODY, 12V		
SHEET: 3 OF 7	ITEM/PART NO: 000201106 / 30168401000	REV:

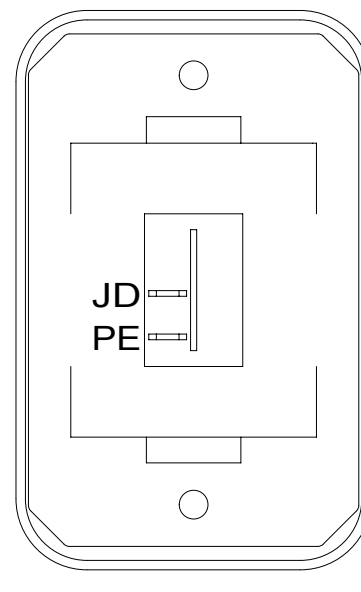

SWITCH-ROCKER
135740-01-CHT
SWITCH-BASE
135741-01-CHT
SWITCH-BEZEL
135742-01-CHT
SCREW
G11-08-08U (2)

DETAIL DA

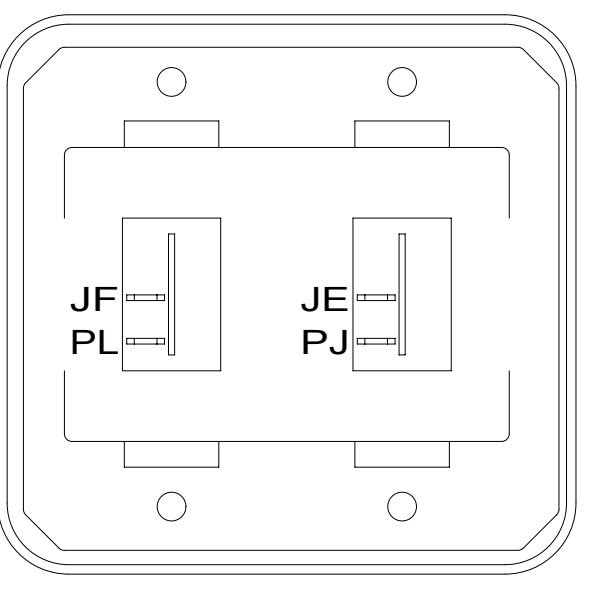

SWITCH-ROCKER
135740-01-CHT (2)
SWITCH-BASE
135741-02-CHT
SWITCH-BEZEL
135742-02-CHT
SCREW
G11-08-08U (4)

DETAIL DF

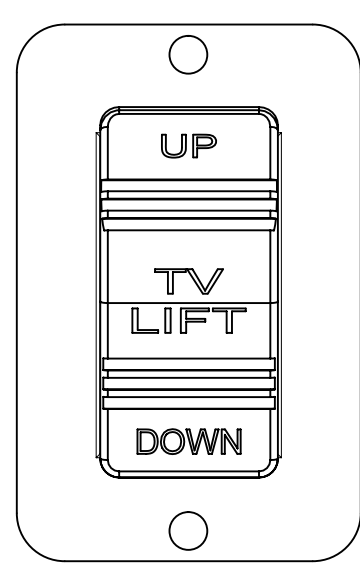

SWITCH-TV LIFT
108357-16-000
ACTUATOR
108356-26-CHT
PLATE
98351-07-CHT
SCREW
G11-06-10U (2)

DETAIL DM 21R

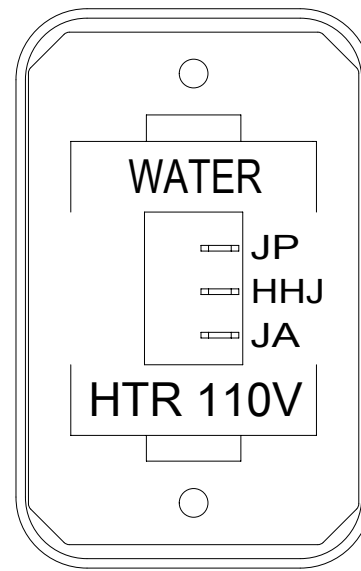

SWITCH-ROCKER
135740-06-CHT
SWITCH-BASE
135741-01-CHT
SWITCH-BEZEL
135742-35-CHT
SCREW
G11-08-08U (2)

DETAIL DB

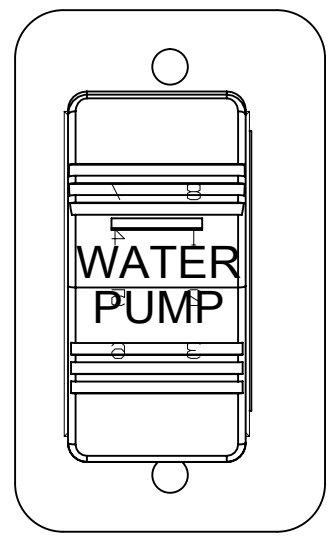

SWITCH-PUMP
108357-15-000
ACTUATOR
108356-23-CHT
PLATE
98351-07-CHT
SCREW
G11-06-10U (2)

DETAIL DG

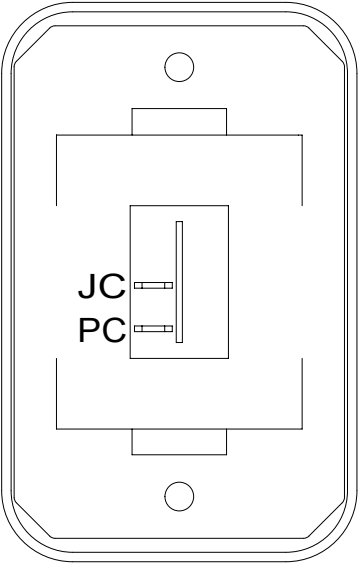

SWITCH-ROCKER
135740-01-CHT
SWITCH-BASE
135741-01-CHT
SWITCH-BEZEL
135742-01-CHT
SCREW
G11-08-08U (2)

DETAIL DN

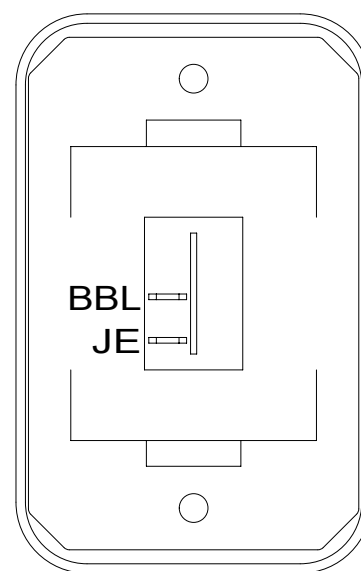

SWITCH-ROCKER
135740-01-CHT
SWITCH-BASE
135741-01-CHT
SWITCH-BEZEL
135742-01-CHT
SCREW
G11-08-08U (2)

DETAIL DC 21R

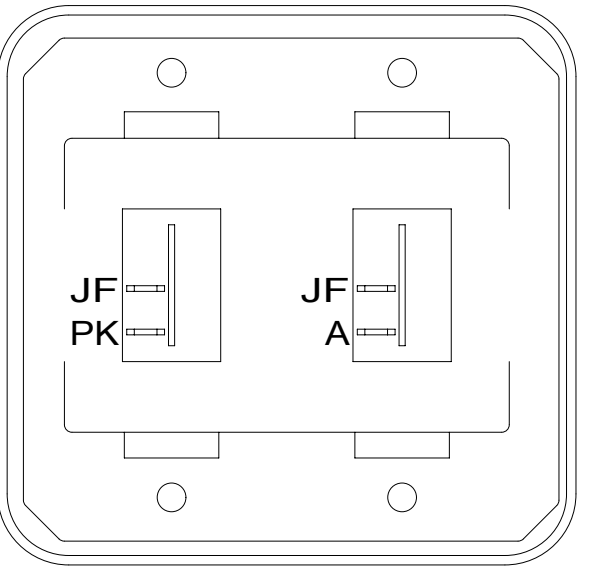

SWITCH-ROCKER
135740-01-CHT (2)
SWITCH-BASE
135741-02-CHT
SWITCH-BEZEL
135742-02-CHT
SCREW
G11-08-08U (4)

DETAIL DJ

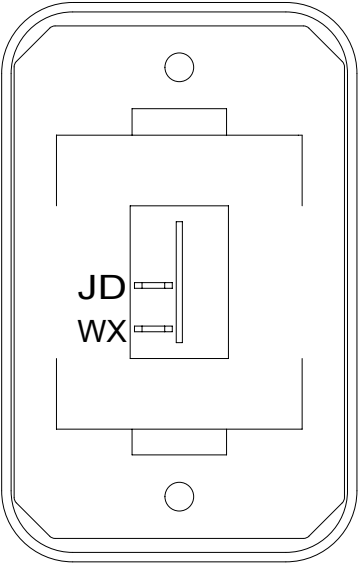

SWITCH-ROCKER
135740-01-CHT
SWITCH-BASE
135741-01-CHT
SWITCH-BEZEL
135742-01-CHT
SCREW
G11-08-08U (2)

DETAIL DP

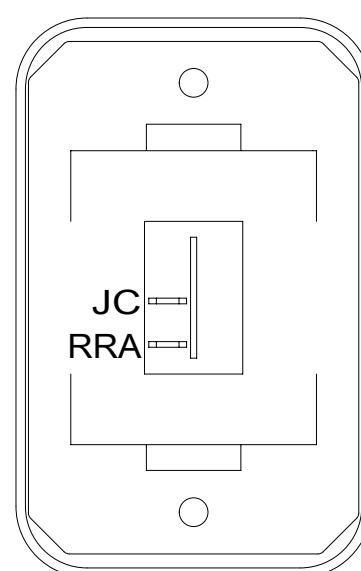

SWITCH-ROCKER
135740-01-CHT
SWITCH-BASE
135741-01-CHT
SWITCH-BEZEL
135742-01-CHT
SCREW
G11-08-08U (2)

DETAIL DD

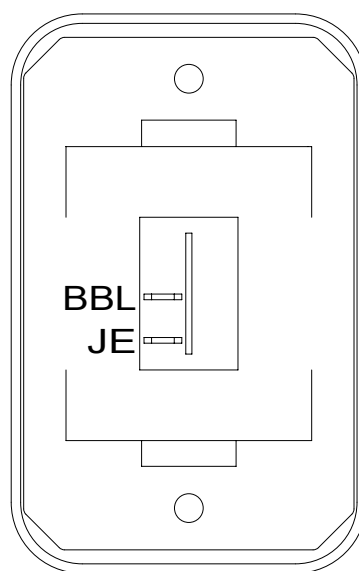

SWITCH-ROCKER
135740-01-CHT
SWITCH-BASE
135741-01-CHT
SWITCH-BEZEL
135742-01-CHT
SCREW
G11-08-08U (2)

DETAIL DL

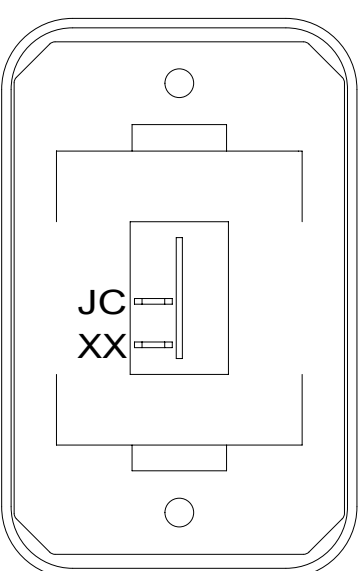

SWITCH-ROCKER
135740-01-CHT
SWITCH-BASE
135741-01-CHT
SWITCH-BEZEL
135742-01-CHT
SCREW
G11-08-08U (2)

DETAIL DR

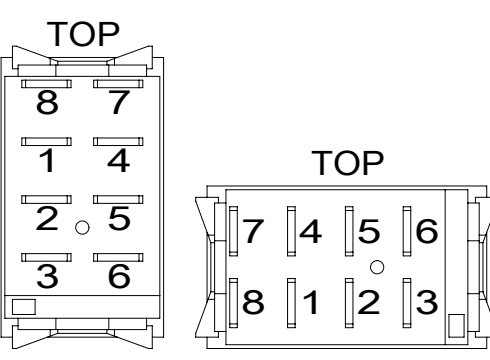

DETAIL DE

SWITCH-CHASSIS BATTERY
108357-18-000
ACTUATOR-SWITCH
108356-20-CHT
CIRCUITS UUC,TTY,UUB,
UUB,TTZ,UUC,UUC,UUA
WIRE ASM-THERM
186796-01-000

SWITCH-COACH BATTERY
108357-18-000
ACTUATOR-SWITCH
108356-19-CHT
CIRCUITS KF,LG,LJ,
LJ,LH,KF,KF,LK
WIRE ASM-THERM
186796-01-000

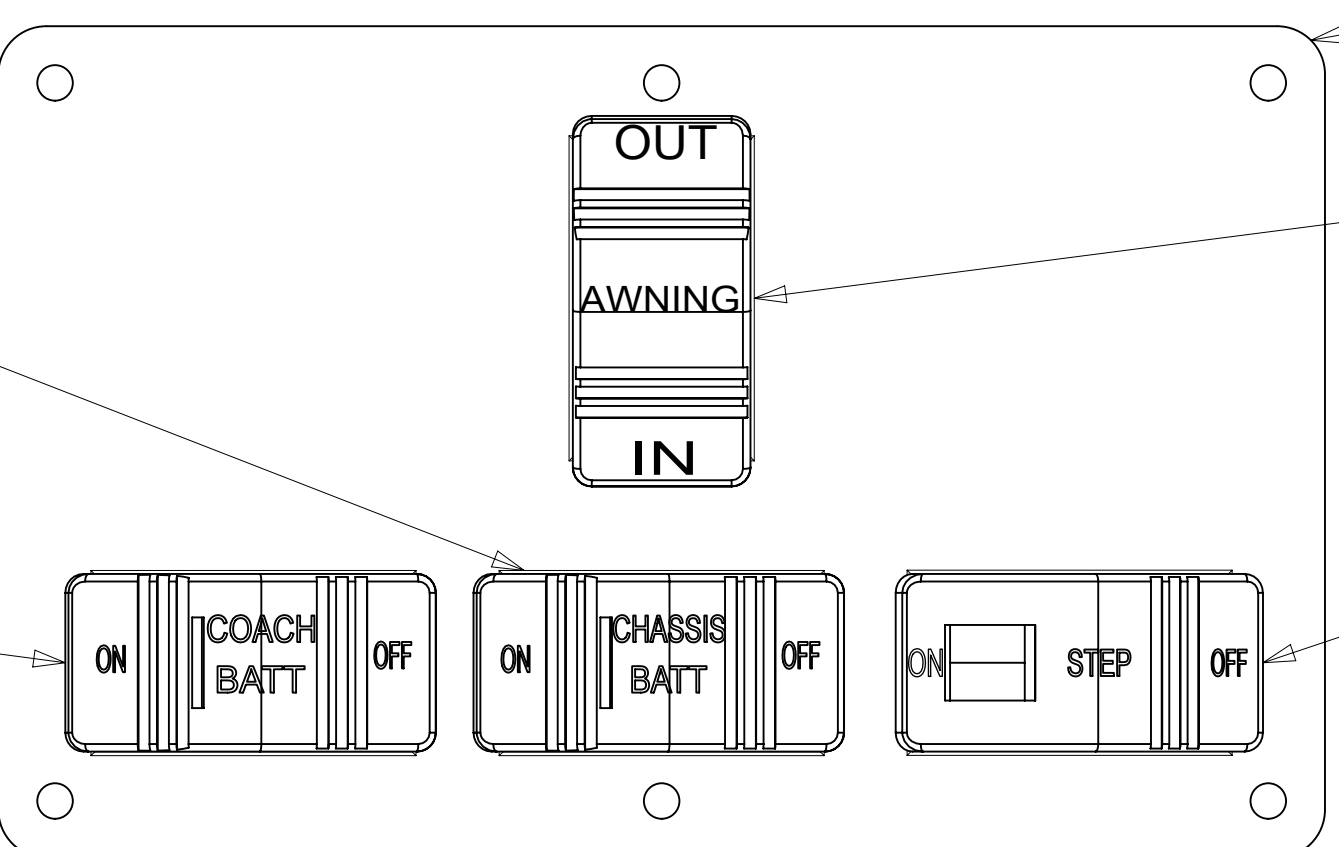

DETAIL DH 1

PLATE-SWITCH
158431-15-CHT
SCREW
G11-06-10U (6)

SWITCH-AWNING
108357-06-000
ACTUATOR-SWITCH
108356-12-CHT
CIRCUITS
FFD,FFR,FFE,
FFE,JJR,FFD

SWITCH-STEP
108357-19-000
CIRCUITS ER,ES

HEX NUT-PALNUT
(SUPPLIED WITH
CIRCUIT BREAKER)

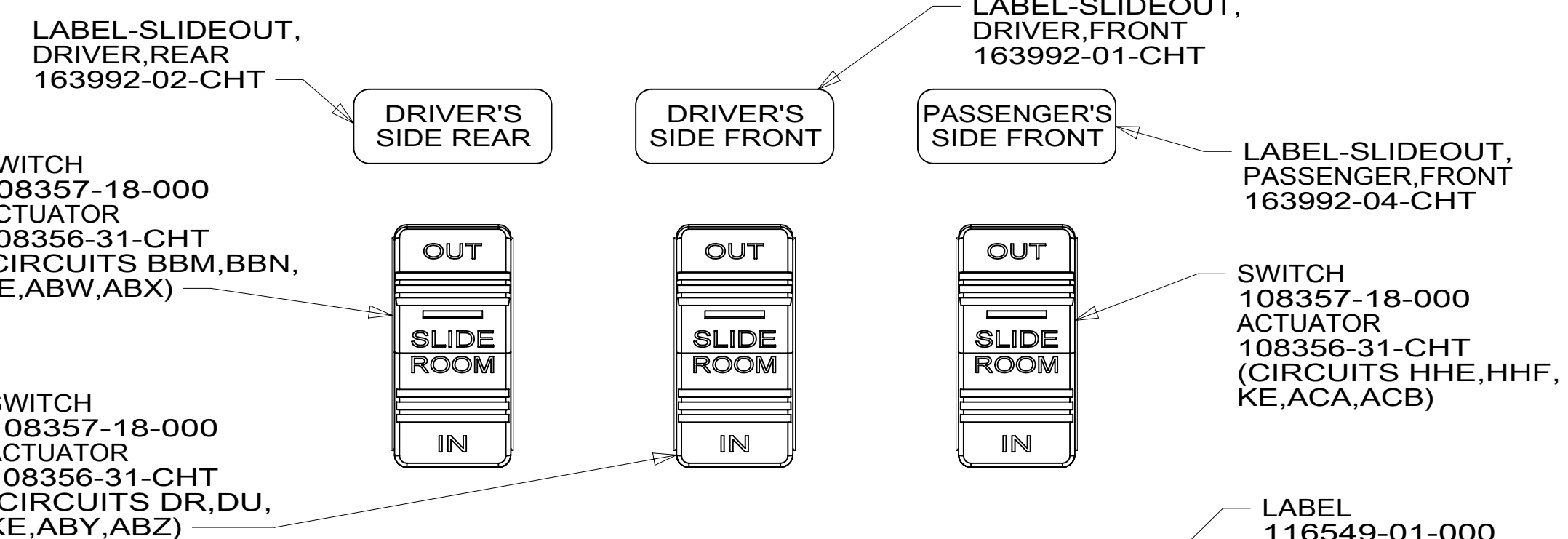

DETAIL DK

WARNING CRUSH HAZARD. Keep people and objects clear of the inside and the outside of the slideout room when operating. Failure to comply could result in death or serious injury.

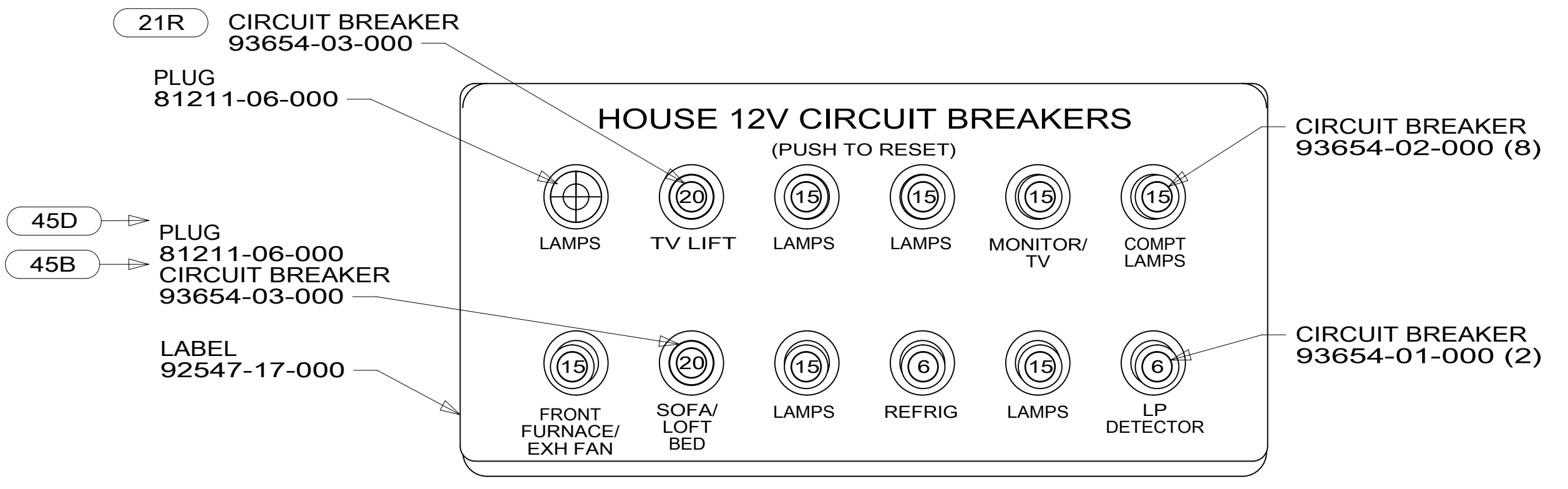

DETAIL DS 078 (FRONT VIEW)

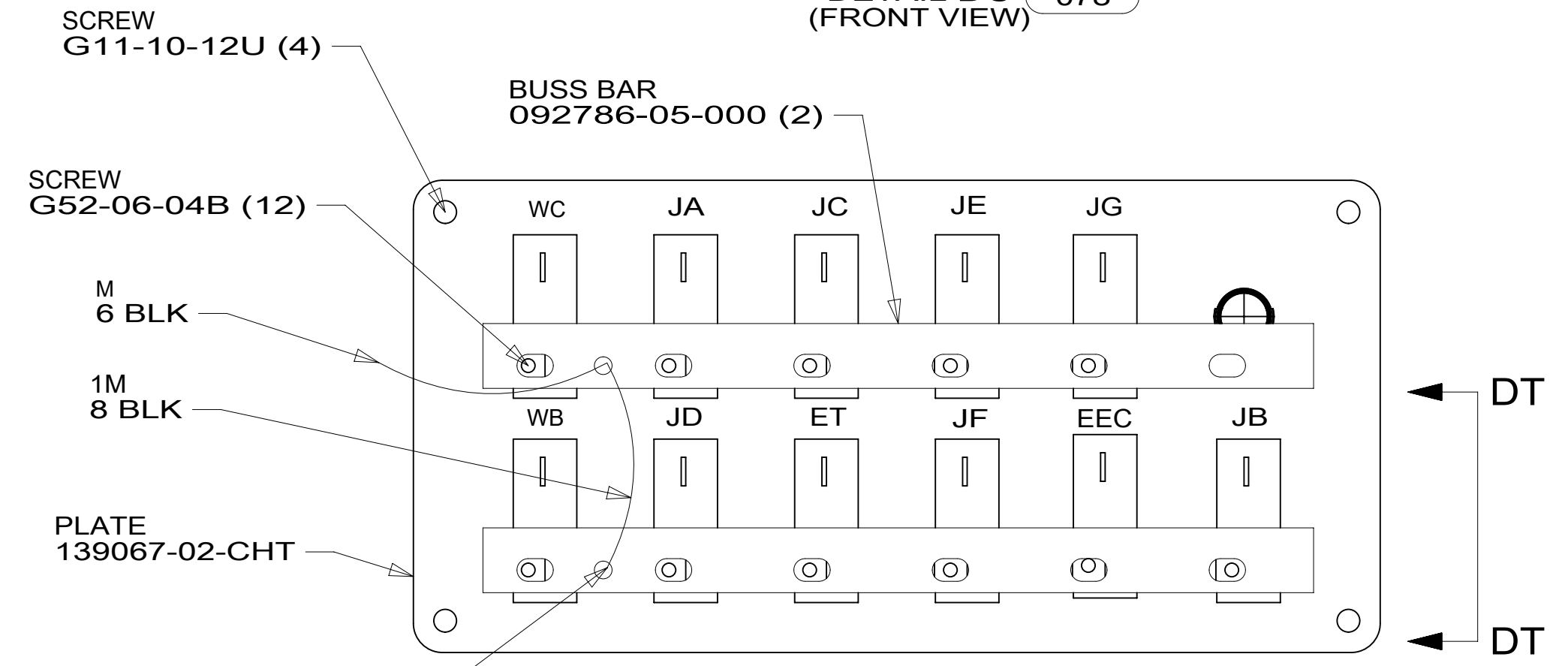

DETAIL DS 078 (BACK VIEW)

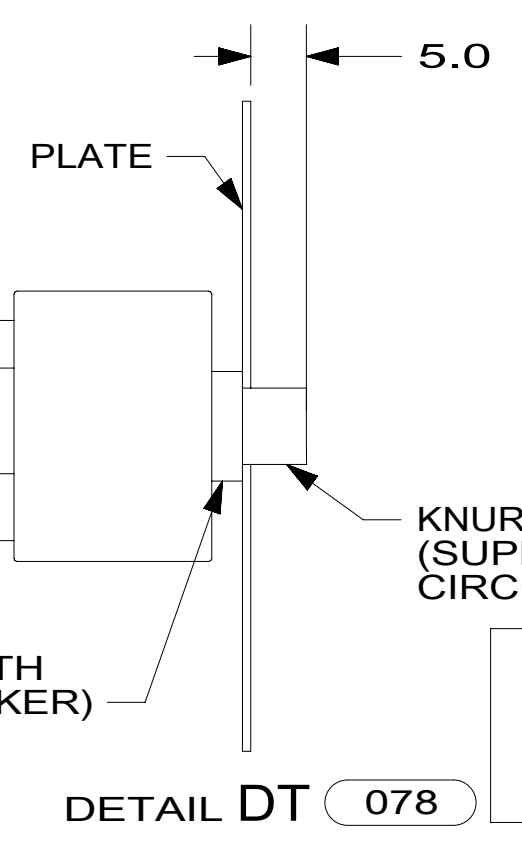

DETAIL DT 078

FOR ELECTRICAL TORQUE SPECIFICATIONS SEE DWG NO. 128783-01-000

FOR ELECTRICAL CALLOUTS SEE DWG NO. 121339-01-000

- 078 ALL WEATHER UPGRADE PACKAGE
- 45B LOFT BED
- 45D LOFT BED - WITHOUT
- 21R DINING/BUFFET/POWERED TV
- 265 CODES/STANDARDS-CSA/CMVSS
- 1B1 CODES/STANDARDS USA

DESCRIPTION: WIRING INSTL-BODY, 12V		
SHEET: 4 OF 7	ITEM/PART NO: 000201106 / 30168401000	REV

NOTES:
1 FOR SWITCH ORIENTATION SEE DETAIL DE

8 7 6 5 4 3 2 1



D

D

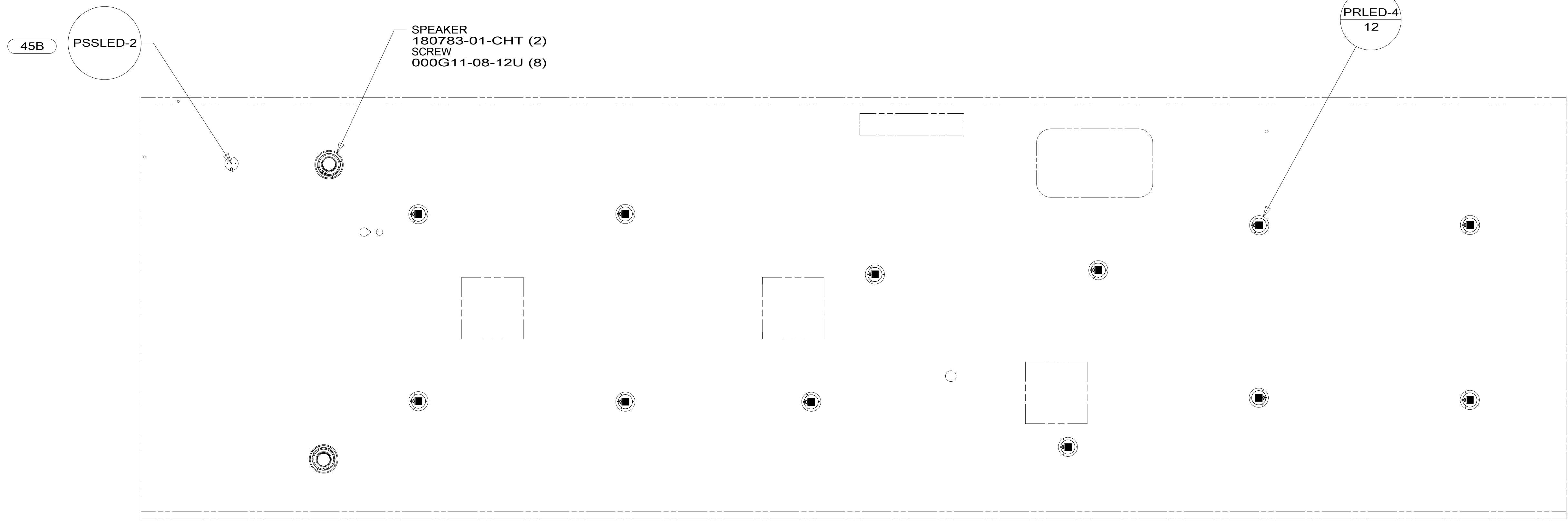

C

C



B

B

A

A

8 7 6 5 4 3 2 1 20-Sep-2016

- 45B LOFT BED
- 265 CODES/STANDARDS-CSA/CMVSS
- 1B1 CODES/STANDARDS USA

FOR ELECTRICAL
TORQUE
SPECIFICATIONS
SEE DWG NO.
128783-01-000

FOR
ELECTRICAL
CALLOUTS
SEE DWG NO.
121339-01-000

1B1	265
DESCRIPTION: WIRING INSTL-BODY, 12V	
SHEET: 5 OF 7	ITEM/PART NO: 000201106 / 30168401000
REV	

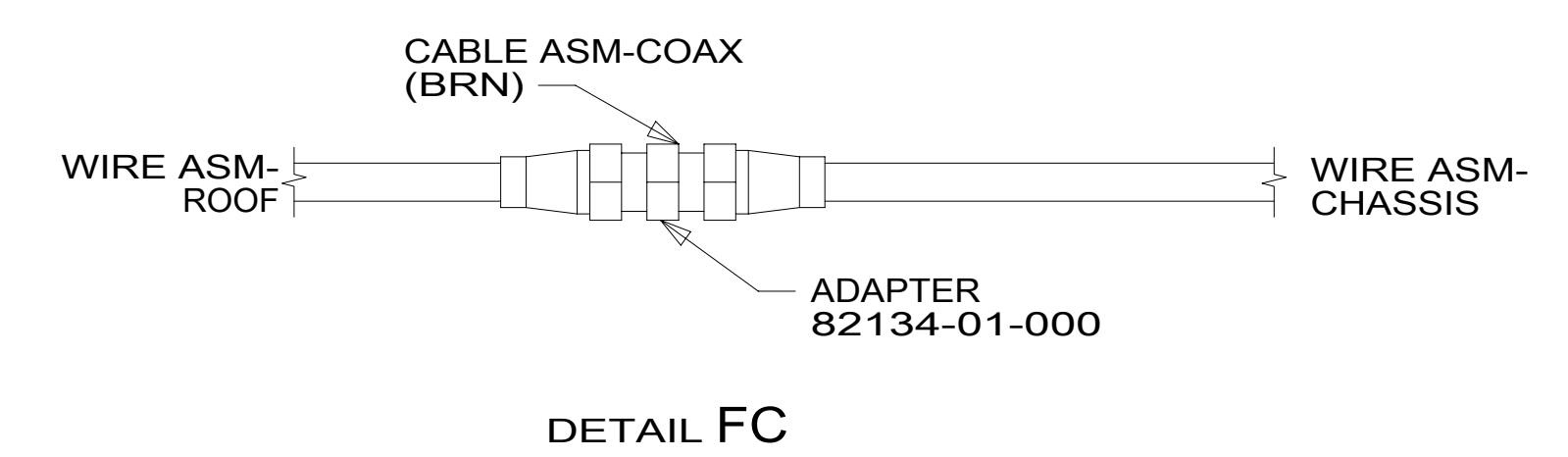
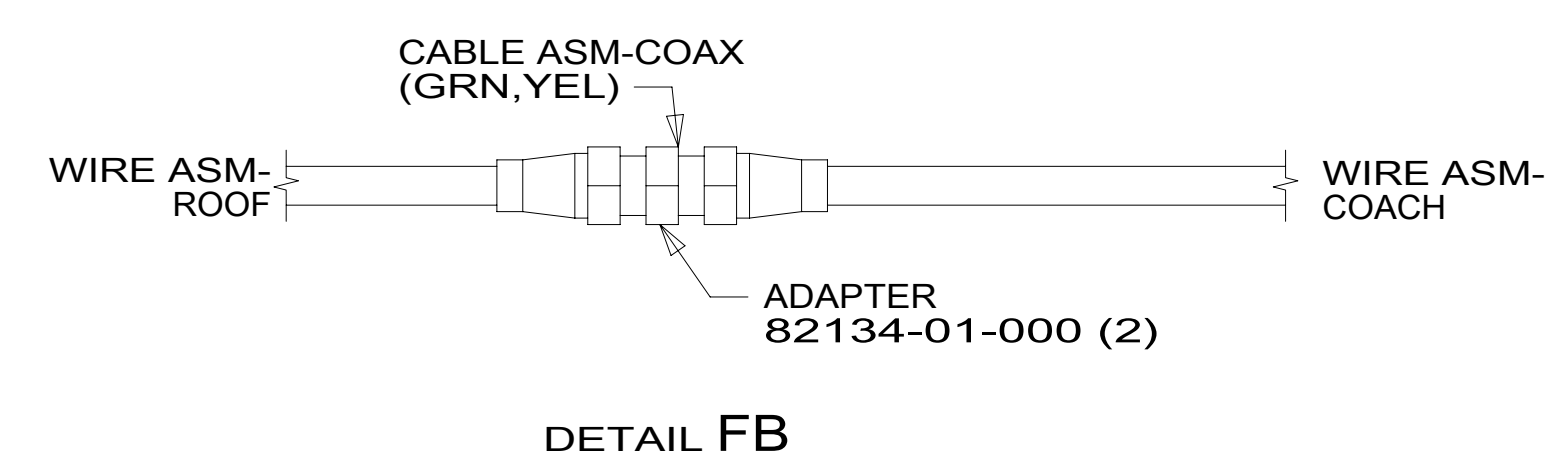
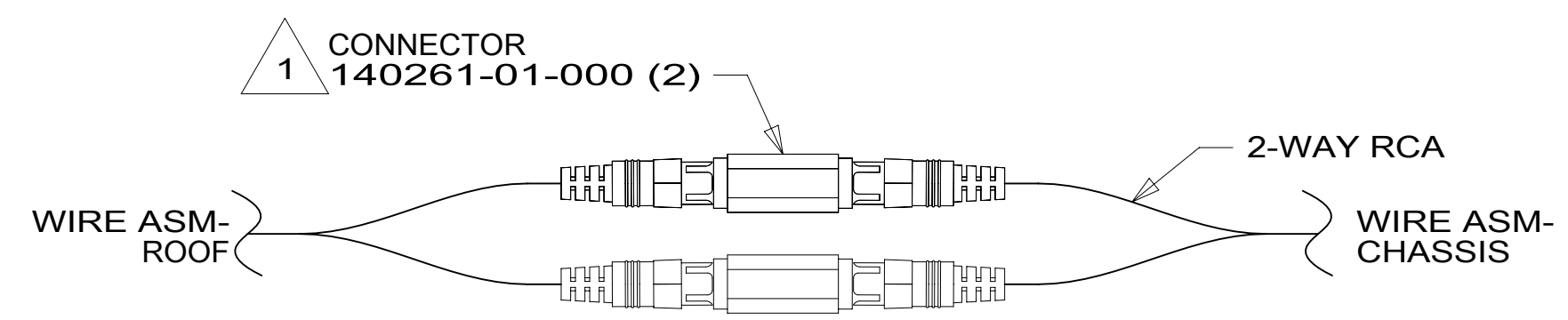
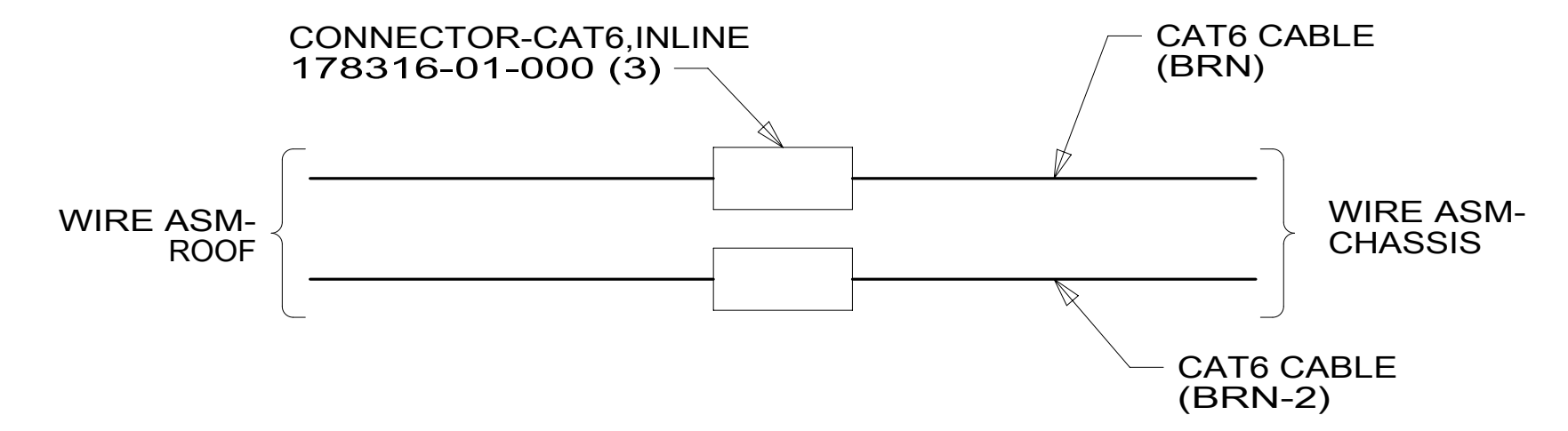
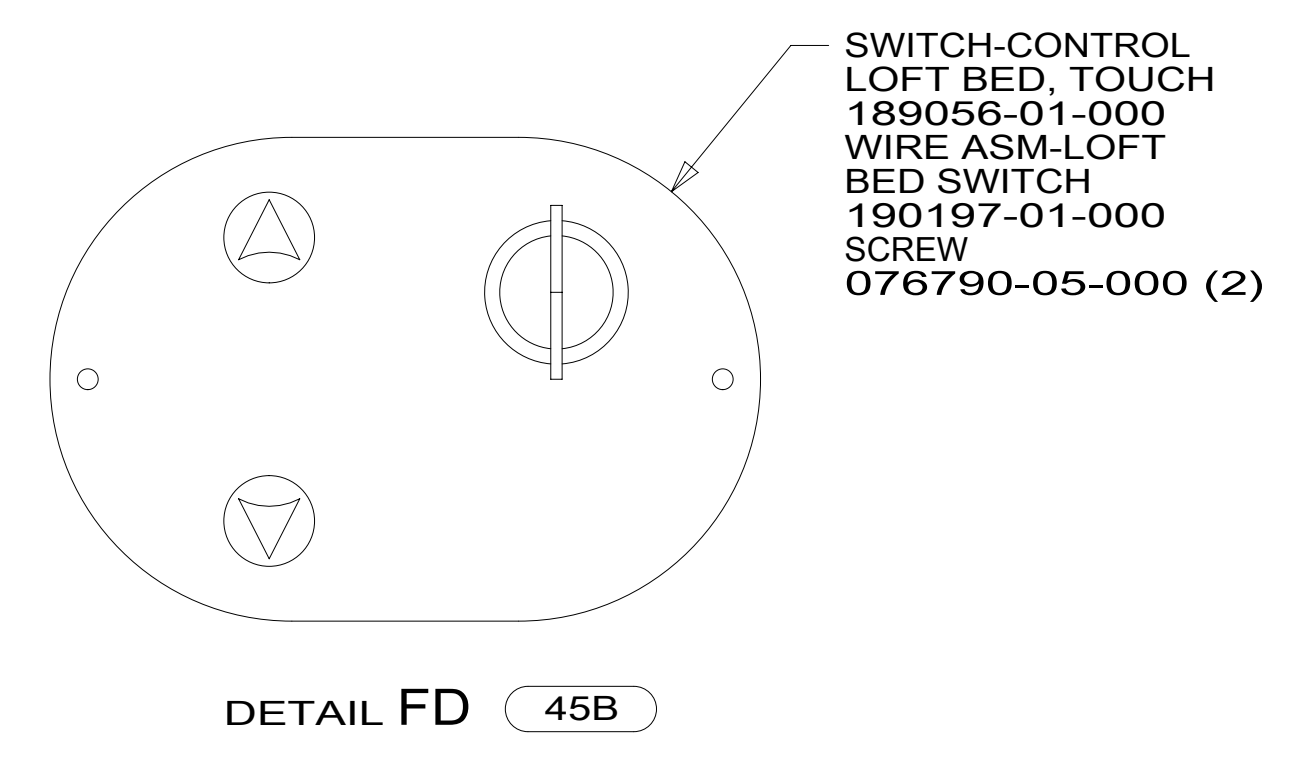
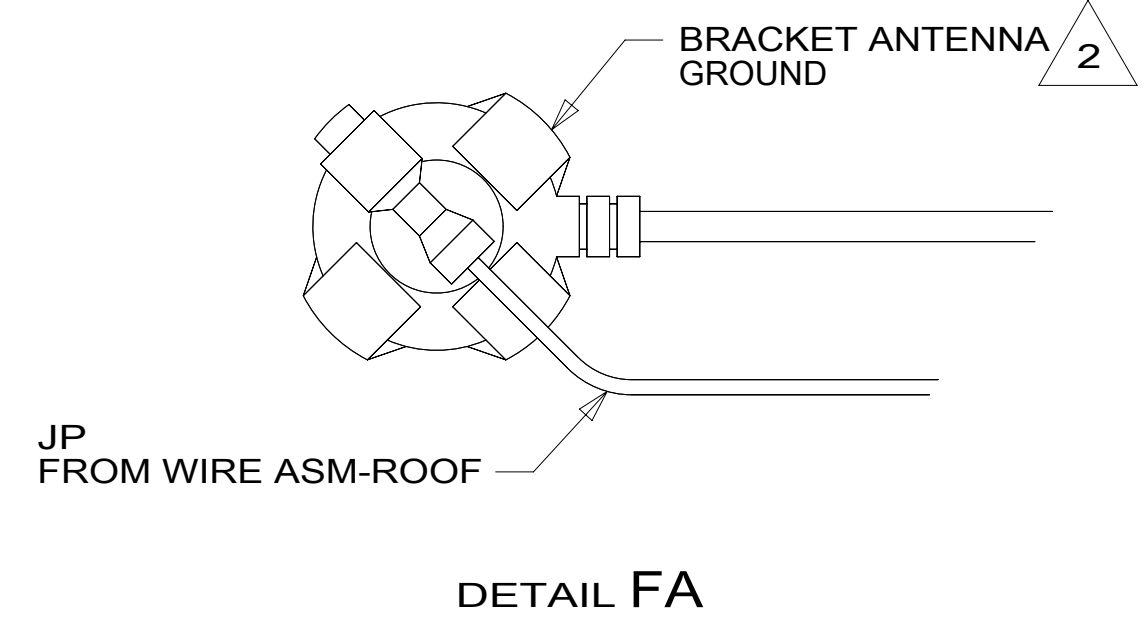
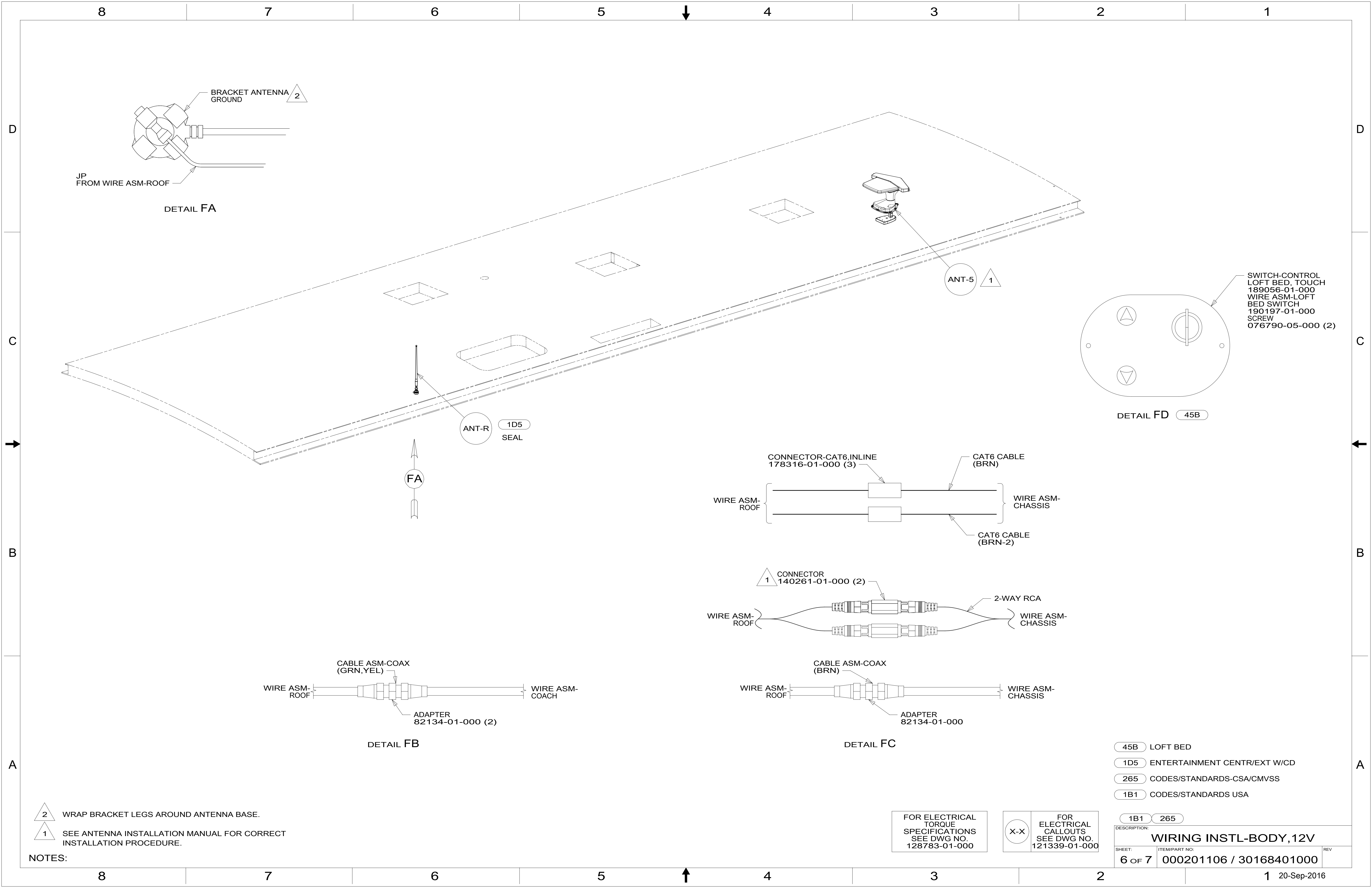

- NOTES:
- 2 WRAP BRACKET LEGS AROUND ANTENNA BASE.
 - 1 SEE ANTENNA INSTALLATION MANUAL FOR CORRECT INSTALLATION PROCEDURE.

FOR ELECTRICAL TORQUE SPECIFICATIONS SEE DWG NO. 128783-01-000

FOR ELECTRICAL CALLOUTS SEE DWG NO. 121339-01-000

- 45B LOFT BED
- 1D5 ENTERTAINMENT CENTR/EXT W/CD
- 265 CODES/STANDARDS-CSA/CMVSS
- 1B1 CODES/STANDARDS USA

DESCRIPTION:		
WIRING INSTL-BODY, 12V		
SHEET:	ITEM/PART NO.:	REV:
6 OF 7	000201106 / 30168401000	

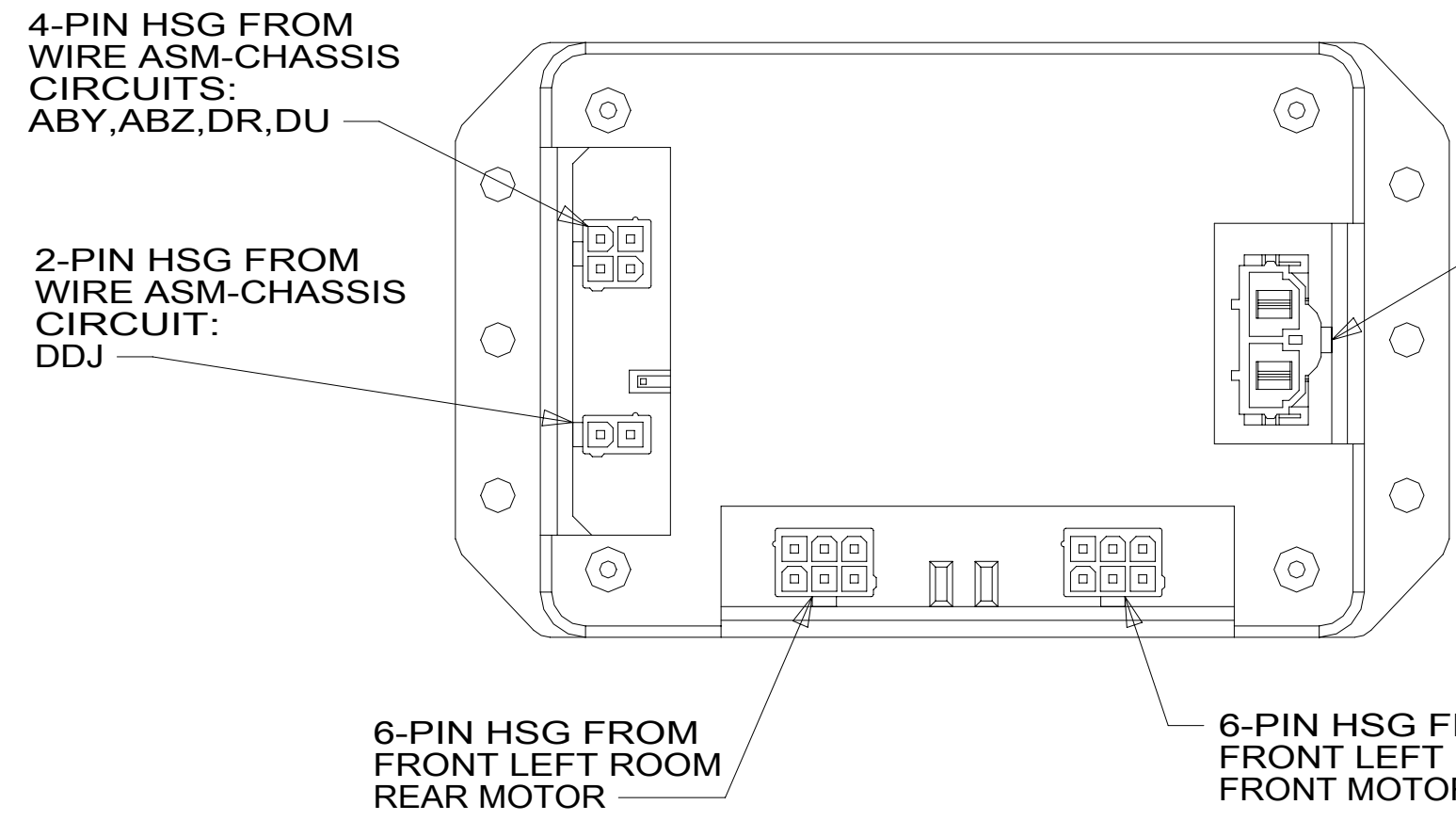
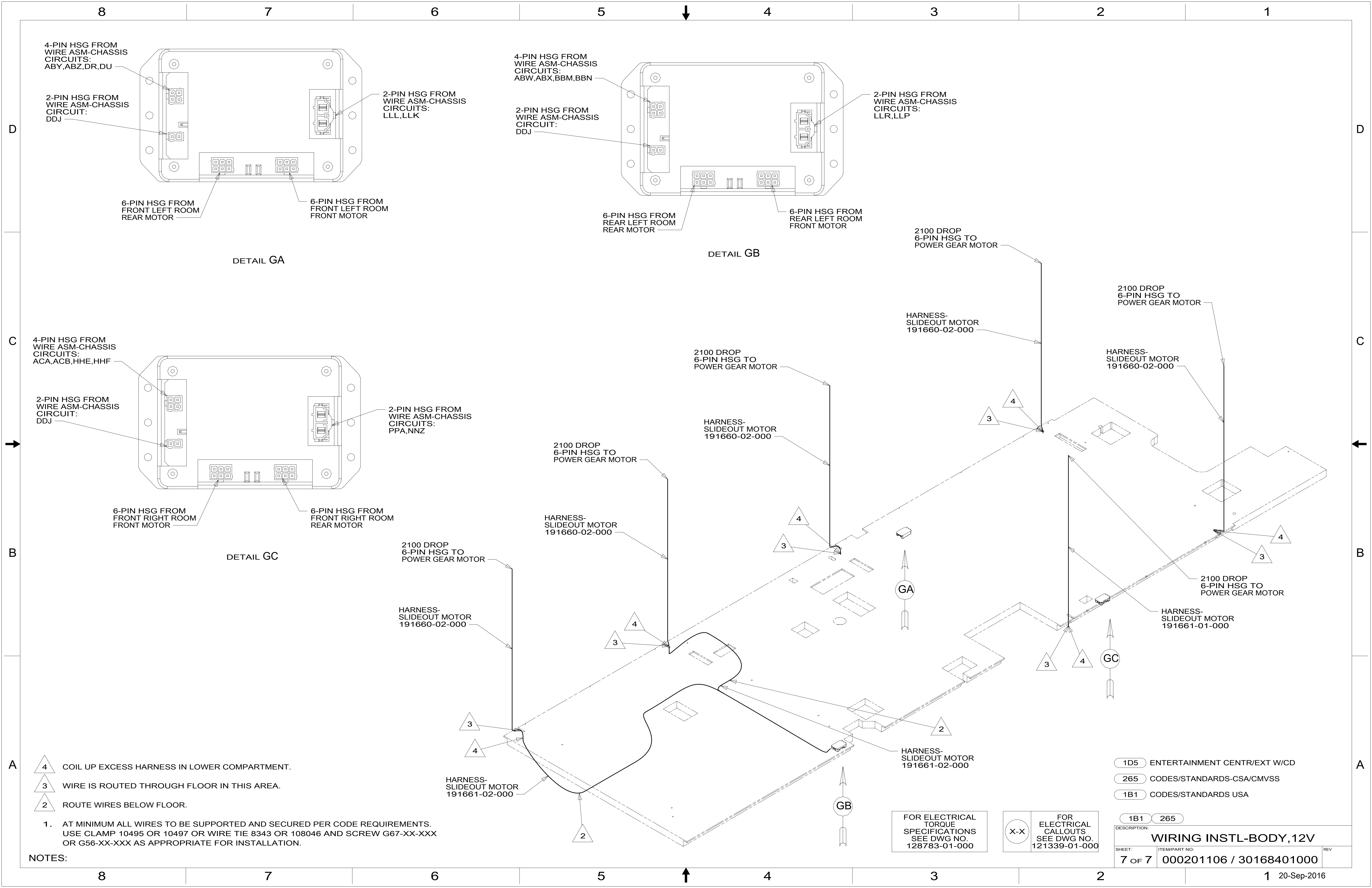

DETAIL GA

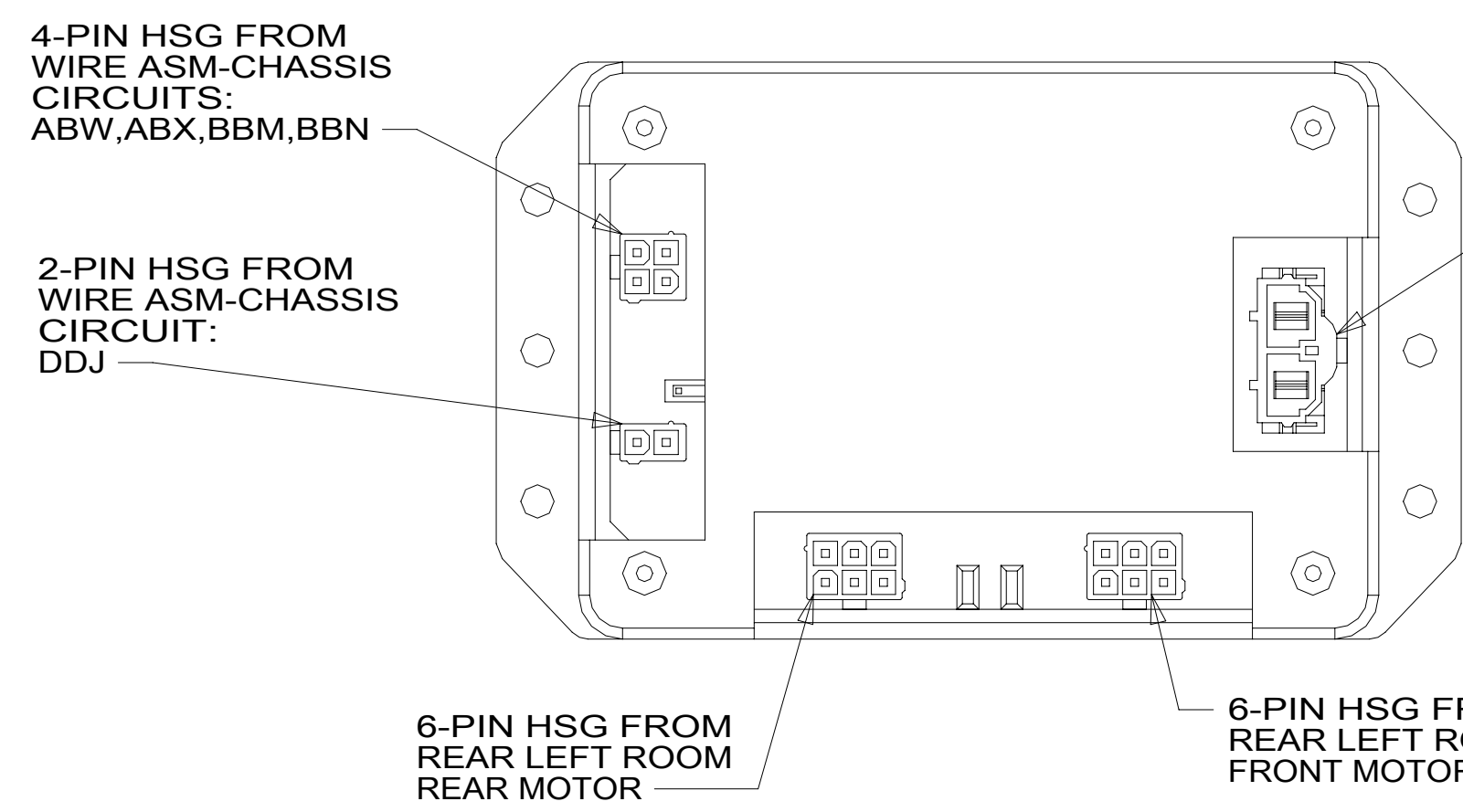

DETAIL GB

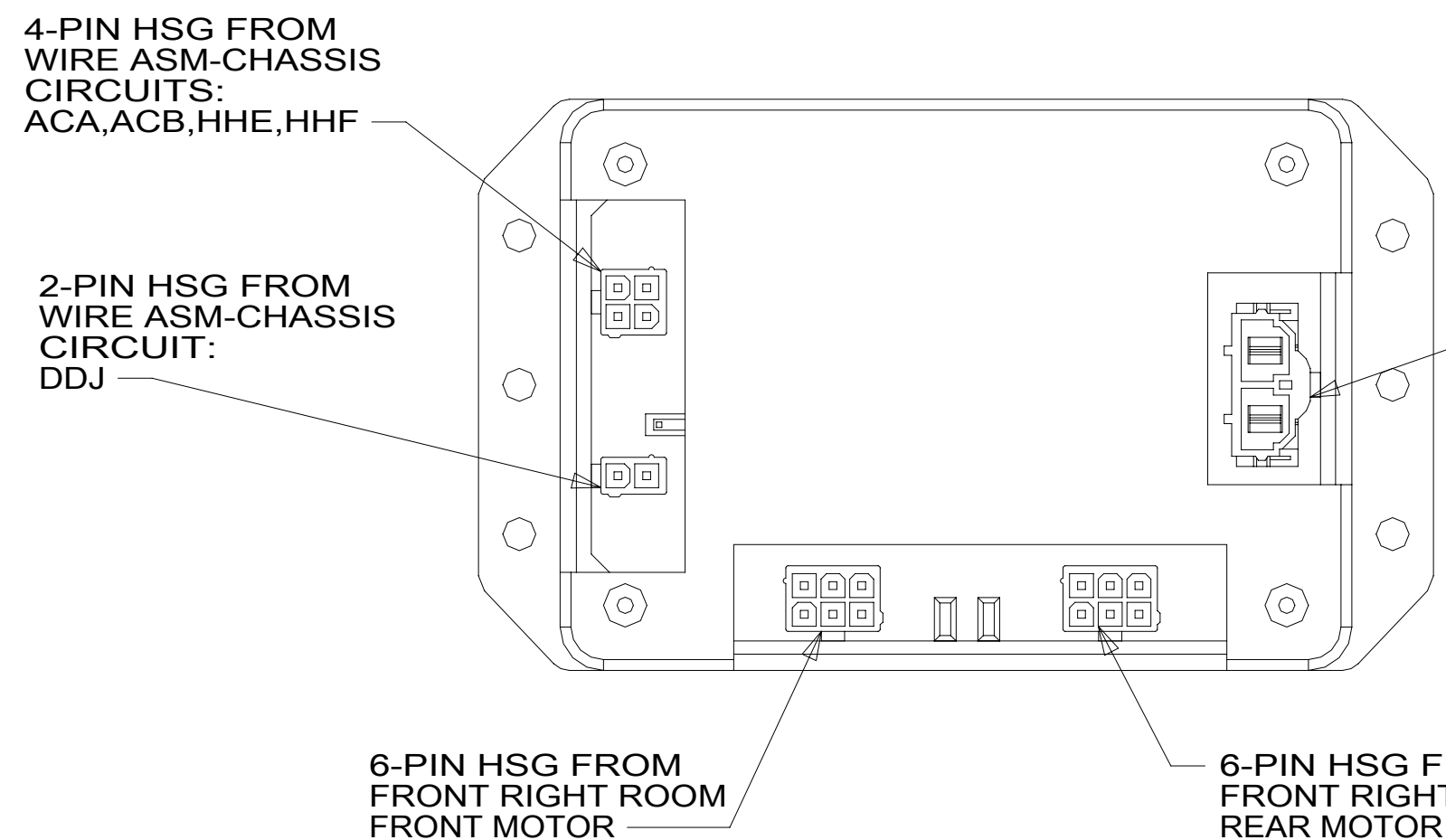

DETAIL GC

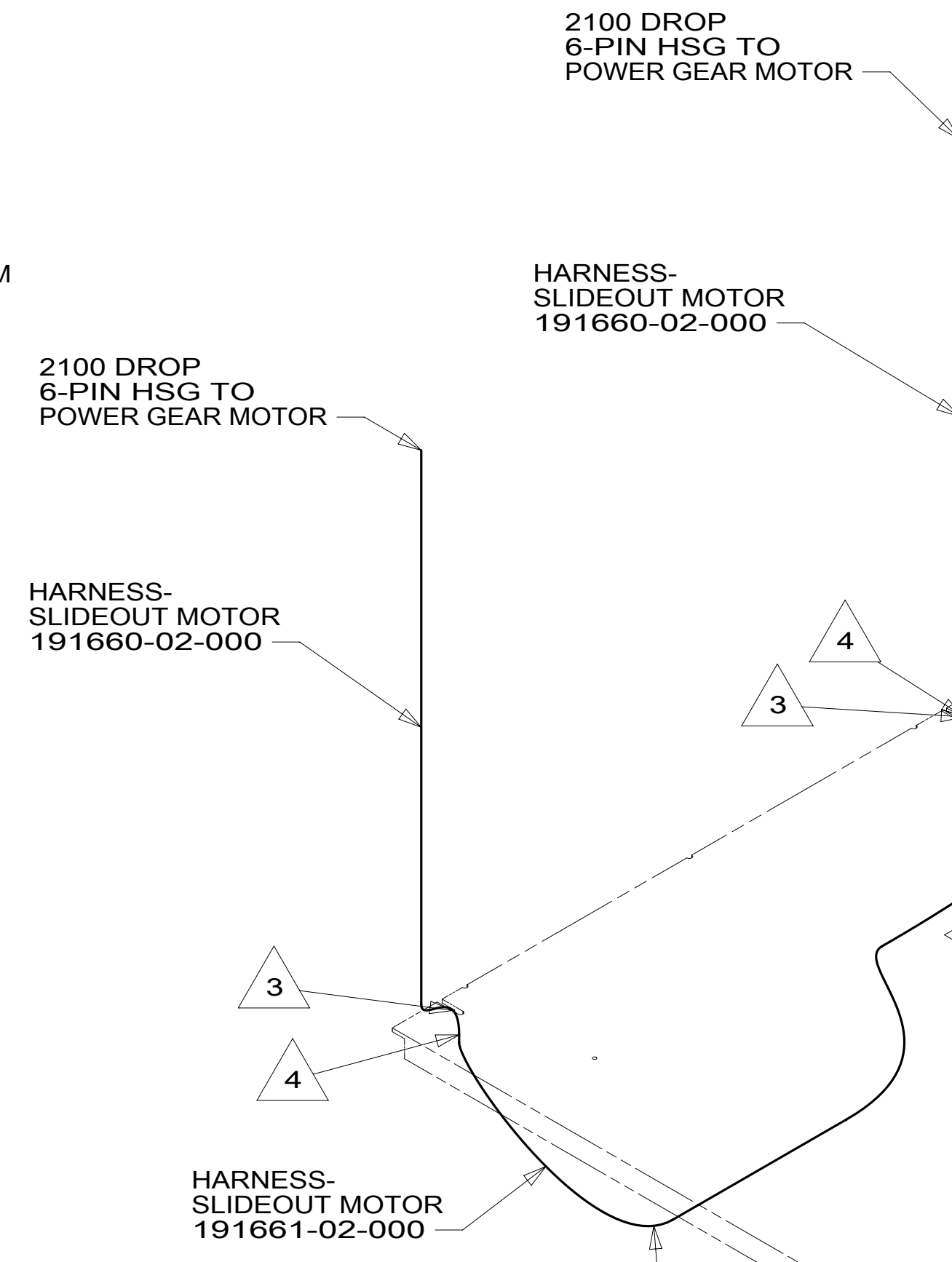

- 4 COIL UP EXCESS HARNESS IN LOWER COMPARTMENT.
- 3 WIRE IS ROUTED THROUGH FLOOR IN THIS AREA.
- 2 ROUTE WIRES BELOW FLOOR.

1. AT MINIMUM ALL WIRES TO BE SUPPORTED AND SECURED PER CODE REQUIREMENTS. USE CLAMP 10495 OR 10497 OR WIRE TIE 8343 OR 108046 AND SCREW G67-XX-XXX OR G56-XX-XXX AS APPROPRIATE FOR INSTALLATION.

NOTES:

FOR ELECTRICAL TORQUE SPECIFICATIONS SEE DWG NO. 128783-01-000

FOR ELECTRICAL CALLOUTS SEE DWG NO. 121339-01-000

- 1D5 ENTERTAINMENT CENTR/EXT W/CD
- 265 CODES/STANDARDS-CSA/CMVSS
- 1B1 CODES/STANDARDS USA

DESCRIPTION:		1B1 265	
WIRING INSTL-BODY, 12V			
SHEET:	ITEM/PART NO:	REV	
7 OF 7	000201106 / 30168401000		