

- 8 SWITCH ON LAMP TO BE ORIENTED TO FRONT OF COACH.
- 7 WITHOUT 68X
- 6 COVER USED TO COVER CAMERA CABLE AND 12V WIRING.
INSTALL WITH COVER TOUCHING TRUNK FLOOR.
- 5 SWITCH ON LAMP TO BE ORIENTED TO REAR OF CABINET.
- 4 SEE WIRING INSTL-TV/DVD FOR ADDITIONAL INFORMATION.
- 3 SEE DRAINAGE SYSTEM INSTALLATION FOR ADDITIONAL INFORMATION.
- 2 SEE LOAD CENTER/ATS ASM FOR ADDITIONAL INFORMATION.

1. AT MINIMUM ALL WIRES TO BE SUPPORTED AND SECURED PER
CODE REQUIREMENTS. USE CLAMP 10495 OR 10497 OR WIRE
TIE 8343 OR 108046 AND SCREW G67-XX-XXX OR G56-XX-XXX AS
APPROPRIATE FOR INSTALLATION.

- 193 TV ANT-DIGITAL AMPLIFIED
- 1J8 TV ANTENNA-OMNIDIRECTIONAL
- 68X TV - BEDROOM
- 640 RENTAL - GAH WITHOUT
- 644 GREAT ALASKAN RENTAL PACKAGE
- 52N AWNING - PATIO,ELECTRIC
- 38E CONVENIENCE PACKAGE
- 23T DRAINAGE SYSTEM - HEATED
- 23R DRAINAGE SYSTEM/HEAT - PREP
- 265 CODES/STANDARDS-CSA/CMVSS
- 1B1 CODES/STANDARDS USA

FOR ELECTRICAL
TORQUE
SPECIFICATIONS
SEE DWG NO.
128783-01-000

X-X

FOR
ELECTRICAL
CALLOUTS
SEE DWG NO.
121339-01-000

DESCRIPTION: WIRING INSTL-BODY, 12V		
1B1 265		
SHEET: 2 OF 5	ITEM/PART NO: 000200787 / 30080601000	REV

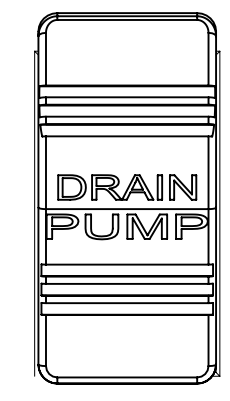

SWITCH-DRAIN PUMP
108357-09-000
ACTUATOR
108356-27-CHT

DETAIL CA

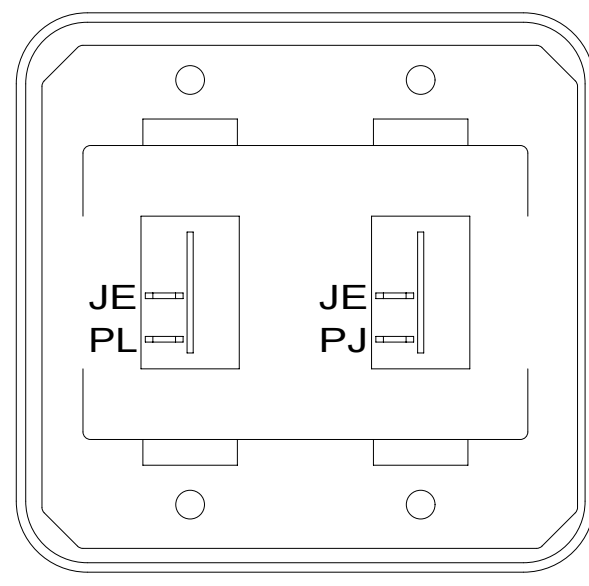

SWITCH-ROCKER
135740-01-CHT (2)
SWITCH-BASE
135741-02-CHT
SWITCH-BEZEL
135742-02-CHT
SCREW
G11-08-08U (4)

DETAIL CE

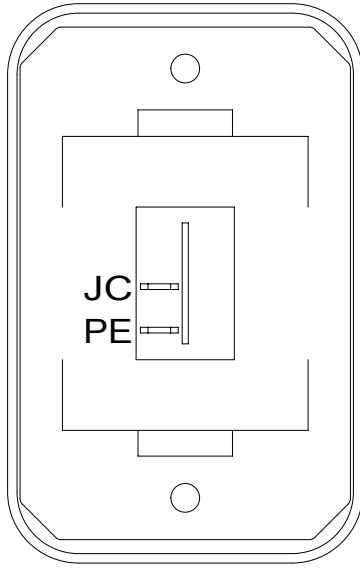

SWITCH-ROCKER
135740-01-CHT
SWITCH-BASE
135741-01-CHT
SWITCH-BEZEL
135742-01-CHT
SCREW
G11-08-08U (2)

DETAIL CB

644 52N
52F

SWITCH-AWNING
108357-06-000
ACTUATOR
108356-12-CHT
SWITCH-BLANK
096241-03-000

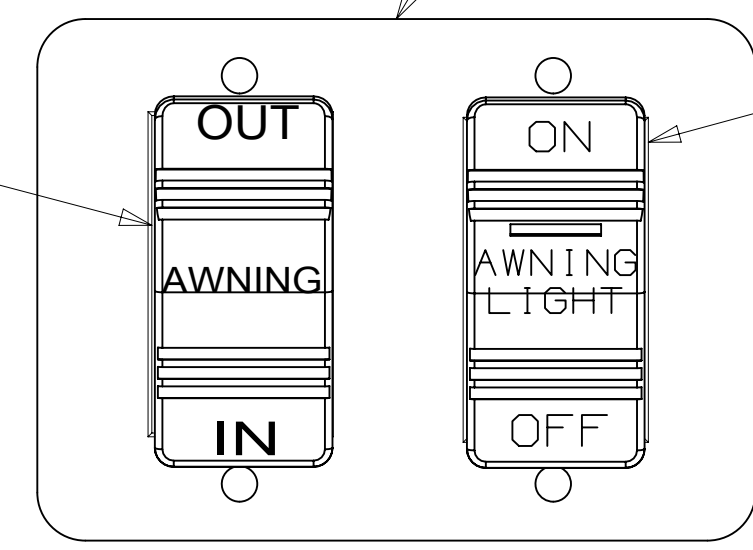

DETAIL CF

SWITCH-AWNING LIGHT
108357-14-000
ACTUATOR
108356-28-CHT
SWITCH-BLANK
096241-03-000

52N 644
52F

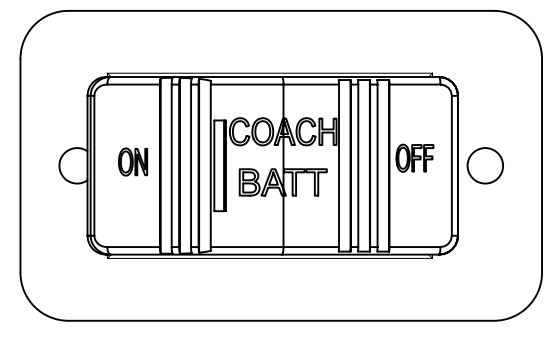

SWITCH-ROCKER
108357-18-000
ACTUATOR-SWITCH
108356-19-CHT
PLATE-SWITCH
098351-07-CHT
SCREW
G11-06-10U (2)
CIRCUITS:
LJ,LJ,LG,JA,JP
WIRE ASM-
THERMISTOR,PTC
186796-01-000

DETAIL CC

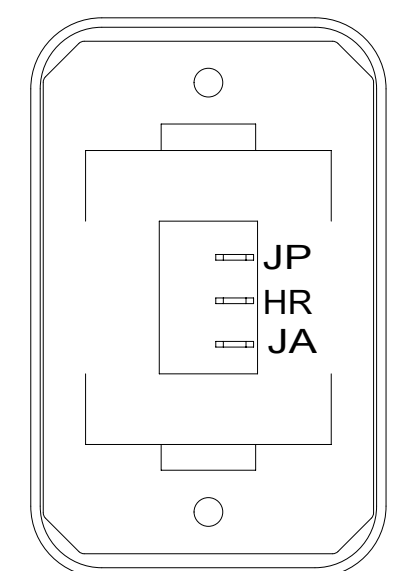

SWITCH-ROCKER
135740-06-CHT
SWITCH-BASE
135741-01-CHT
SWITCH-BEZEL
135742-01-CHT
SCREW
G11-08-08U (2)
LABEL-SWITCH
134563-01-CHT

DETAIL CH 23T 23R

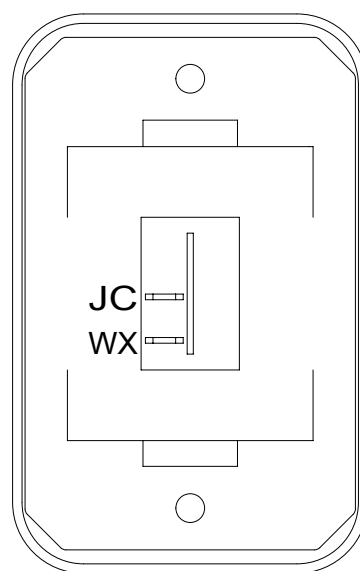

SWITCH-ROCKER
135740-01-CHT
SWITCH-BASE
135741-01-CHT
SWITCH-BEZEL
135742-01-CHT
SCREW
G11-08-08U (2)

DETAIL CK

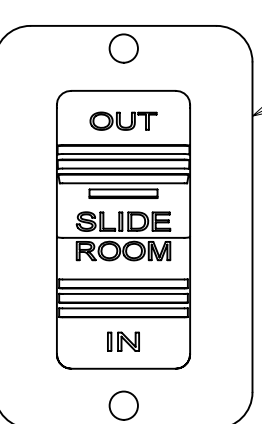
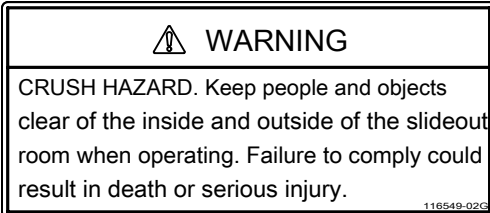

PLATE-SWITCH
144363-02-CHT
SWITCH-ROCKER
108357-18-000
ACTUATOR-SWITCH
108356-31-CHT
SCREW
G11-08-08U (2)

DETAIL CD



LABEL-WARNING,SLIDEOUT
116549-02-000

HOLDING TANK HEATER
TURN OFF When Not In Use
SEE OPERATORS MANUAL

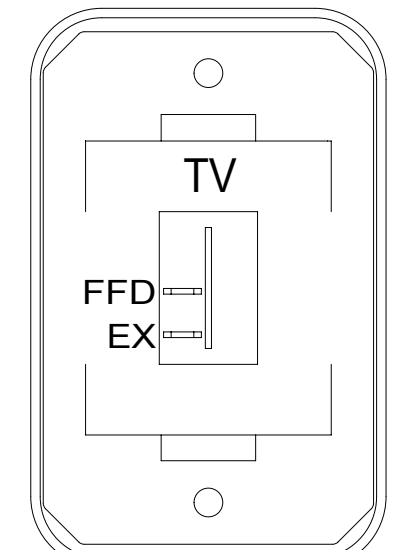

SWITCH-ROCKER
135740-01-CHT
SWITCH-BASE
135741-01-CHT
SWITCH-BEZEL
135742-45-CHT
SCREW
G11-08-08U (2)

DETAIL CJ 644

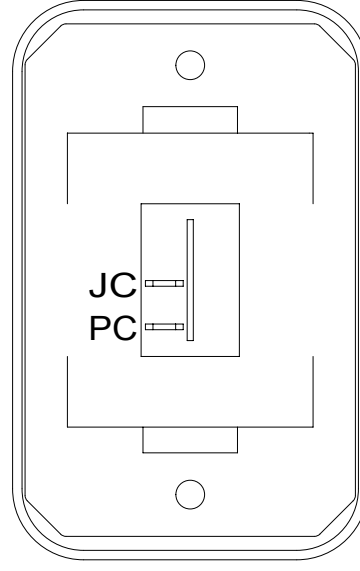

SWITCH-ROCKER
135740-01-CHT
SWITCH-BASE
135741-01-CHT
SWITCH-BEZEL
135742-01-CHT
SCREW
G11-08-08U (2)

DETAIL CL

8 GRN
(GROUND)

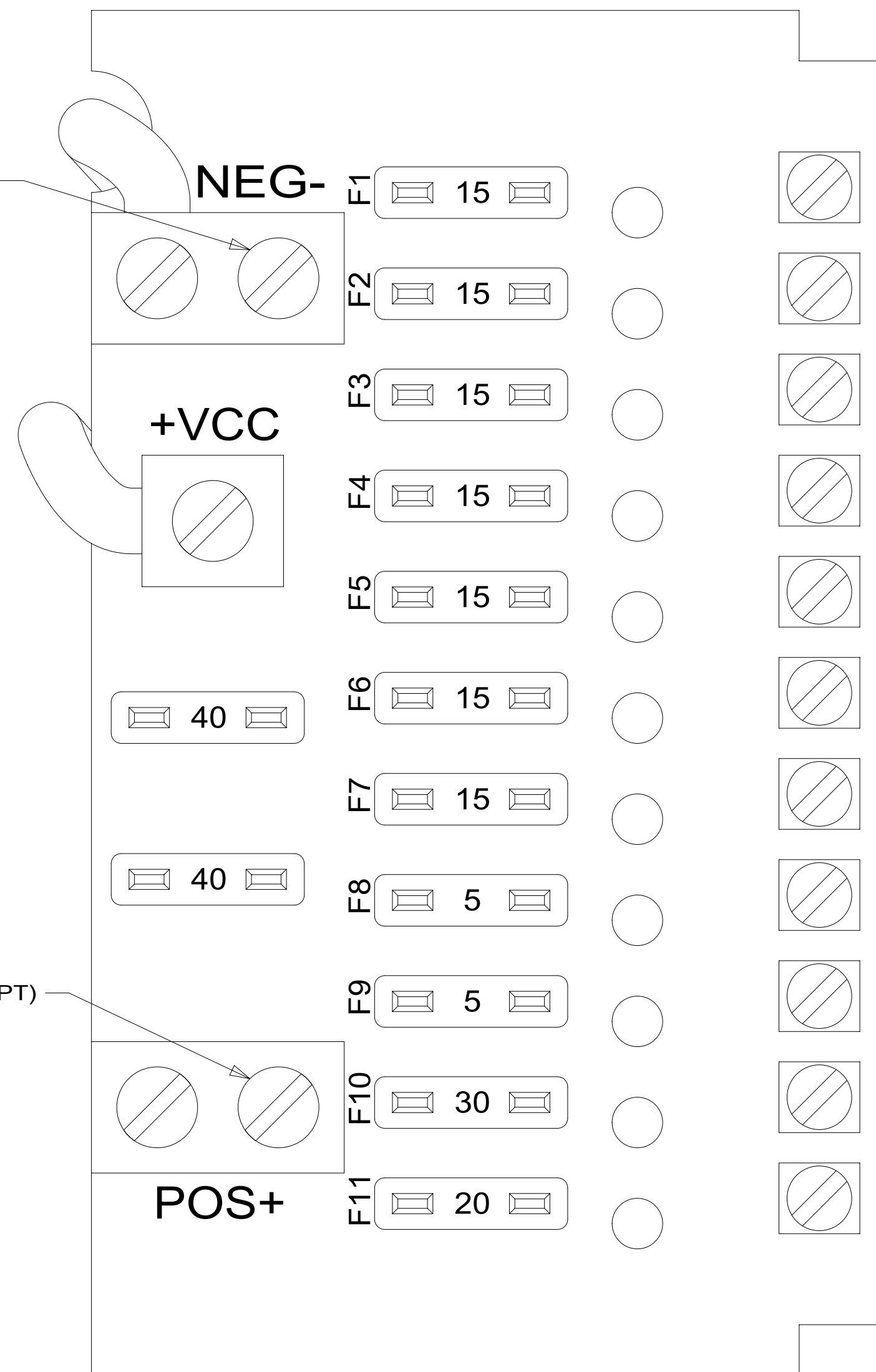

- JC 14 YEL (LAMPS)
- JD 14 YEL (LAMPS)
- JE 14 YEL (LAMPS)
- NM 14 YEL (HEATED TANKS) 23R OR 23T
- JA 12 YEL (MONITOR PANEL & PUMP) (ISOLATED CIRCUIT)
- JB 14 YEL (FURNACE)
- FFD 12 YEL (AWNING) (TV/RADIO)
- WB 16 YEL (CO/LP GAS DETECTOR)
- ET 16 YEL (REFRIG)
- LLK 10 YEL (FRONT SLIDEOUT)
- JG 10 YEL (MACERATOR PUMP)

DETAIL CG 1

- 52F AWNING-PATIO
- 644 GREAT ALASKAN RENTAL PACKAGE
- 52N AWNING - PATIO, ELECTRIC
- 23R DRAINAGE SYSTEM/HEAT-PREWIRE
- 23T DRAINAGE SYSTEM-HEATED
- 265 CODES/STANDARDS-CSA/CMVSS
- 1B1 CODES/STANDARDS USA

FOR ELECTRICAL TORQUE SPECIFICATIONS SEE DWG NO. 128783-01-000

FOR ELECTRICAL CALLOUTS SEE DWG NO. 121339-01-000

DESCRIPTION: WIRING INSTL-BODY, 12V		
SHEET: 3 OF 5	ITEM/PART NO: 000200787 / 30080601000	REV

NOTES:
1 SEE LOAD CENTER/ATS ASM FOR ADDITIONAL INFORMATION.

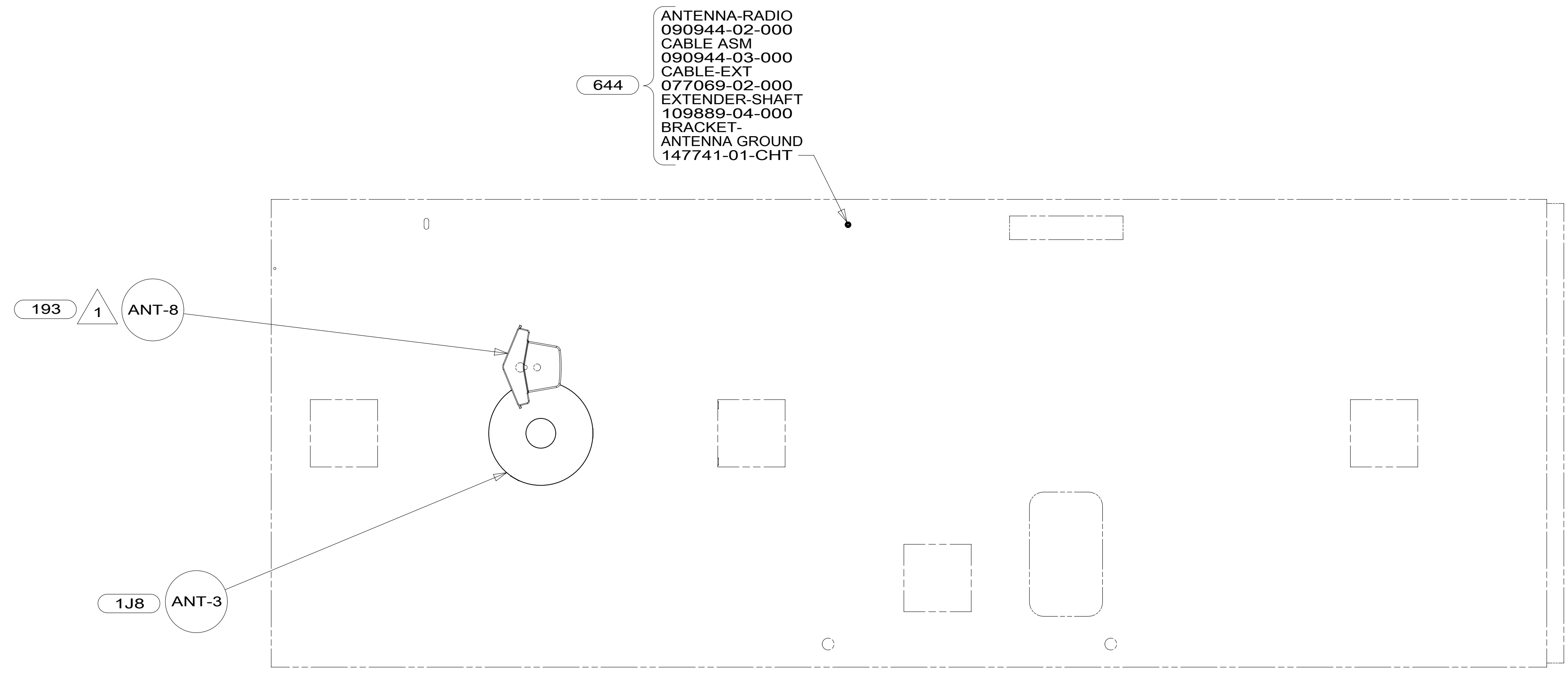
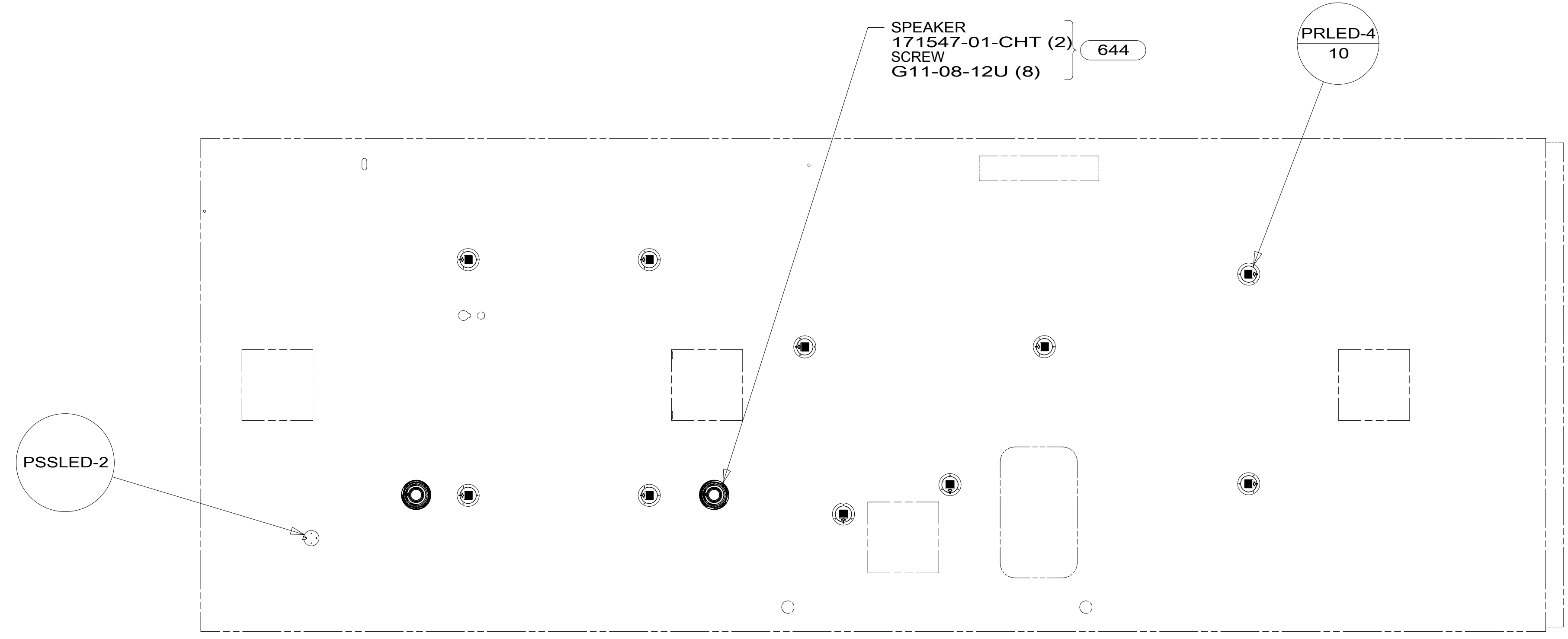

- 1J8 TV ANTENNA-OMNI DIRECTIONAL
- 644 GREAT ALASKAN RENTAL PACKAGE
- 193 TV ANTENNA-AMPLIFIED SYSTEM
- 265 CODES/STANDARDS-CSA/CMVSS
- 1B1 CODES/STANDARDS USA

1 SEE ANTENNA INSTALLATION MANUAL FOR CORRECT INSTALLATION PROCEDURE.

FOR ELECTRICAL TORQUE SPECIFICATIONS SEE DWG NO. 128783-01-000

FOR ELECTRICAL CALLOUTS SEE DWG NO. 121339-01-000

DESCRIPTION: WIRING INSTL-BODY, 12V		
SHEET: 4 OF 5	ITEM/PART NO: 000200787 / 30080601000	REV

8 7 6 5 4 3 2 1

D

C

B

A

D

C

B

A

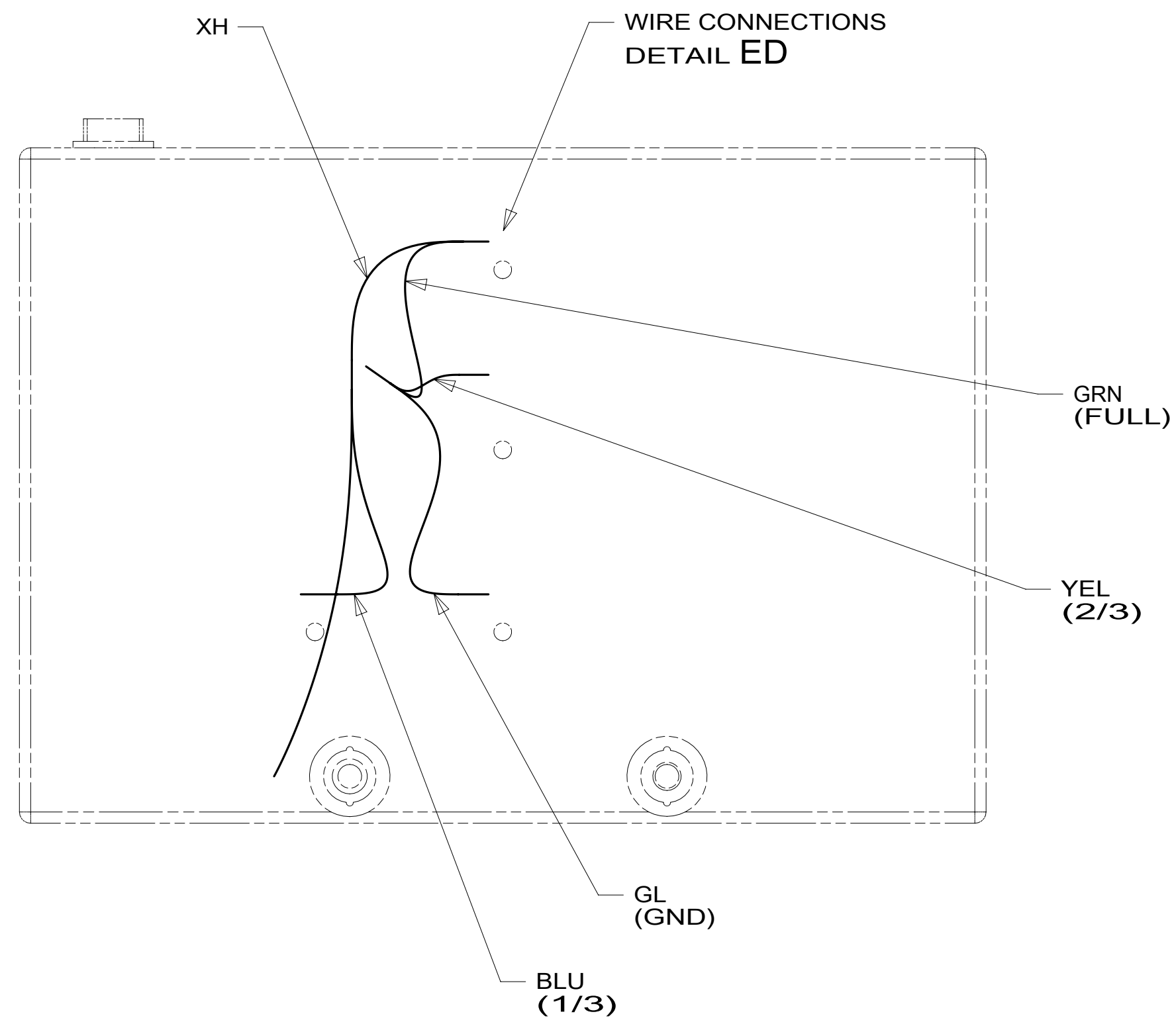

VIEW EA

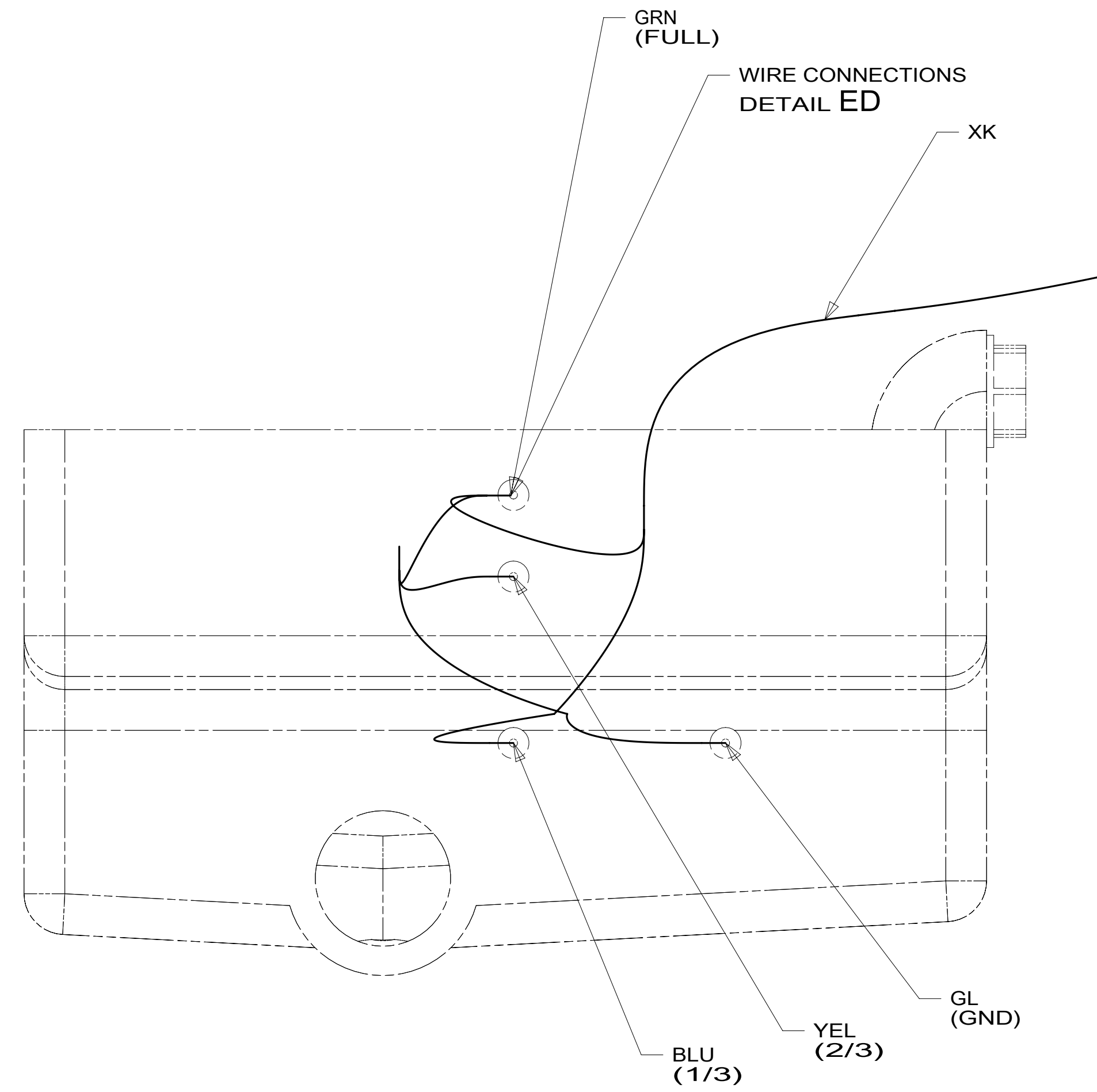

VIEW EB

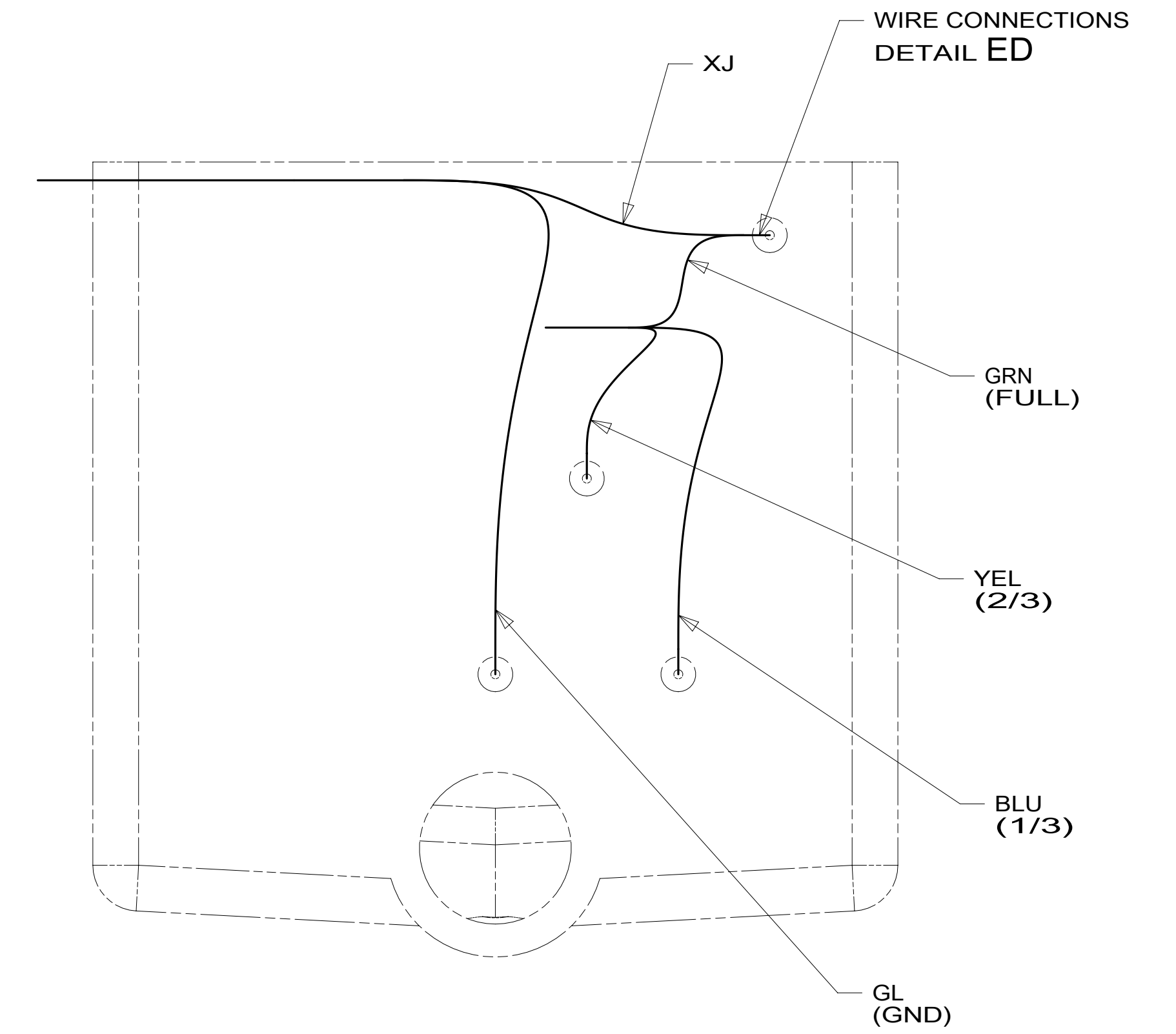

VIEW EC

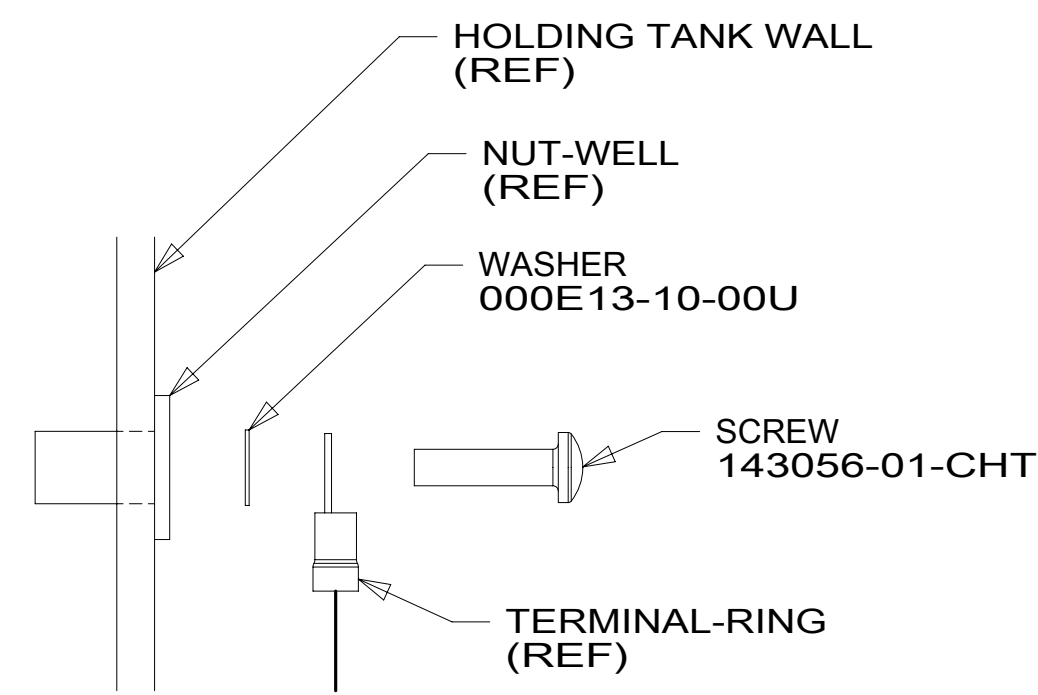

DETAIL ED 1

1 TYPICAL WIRE ATTACHMENT AT ALL LEVEL PROBES (4 EACH) FOR WATER, MAIN, AND AUX HOLDING TANKS.

NOTES:

FOR ELECTRICAL TORQUE SPECIFICATIONS SEE DWG NO. 128783-01-000

FOR ELECTRICAL CALLOUTS SEE DWG NO. 121339-01-000

265 CODES/STANDARDS-CSA/CMVSS

1B1 CODES/STANDARDS USA

1B1 265

DESCRIPTION: WIRING INSTL-BODY, 12V

SHEET: 5 OF 5 ITEM/PART NO: 000200787 / 30080601000 REV

8 7 6 5 4 3 2 1 20-Sep-2016