

8 7 6 5 4 3 2 1

LEXT-1
SEAL

BB

BA

LAMP-MARKER,W RED LENS,BLK
193802-04-000
GASKET-LIGHT
193802-05-000
SCREW
G11-08-12U (EXT) (2)

LAMP-MARKER,W AMBER LENS,BLK
193802-03-000
GASKET-LIGHT
193802-05-000
SCREW
G11-08-12U (EXT) (2)

LAMP-MARKER,W RED LENS,BLK
193802-04-000
GASKET-LIGHT
193802-05-000
SCREW
G11-08-12U (EXT) (2)

LAMP-MARKER,W AMBER LENS,BLK
193802-03-000
GASKET-LIGHT
193802-05-000
SCREW
G11-08-12U (EXT) (2)

265 CODES/STANDARDS-CSA/CMVSS
1B1 CODES/STANDARDS-USA

1B1 265



DSNR:		ALL DIMENSIONS ARE IN MILLIMETERS	
DFFR:		MATERIAL:	
UNSPECIFIED TOLERANCES:			
WHOLE DIM (X)	3		
ONE-PLACE (X.X)	1.5		
TWO-PLACE (X.XX)	0.50		
ANGLE	1°		
REFER TO ES0018 FOR FASTENER TIGHTENING GUIDELINES		WEIGHT: (LBS)	FIRST USED:

FOR ELECTRICAL TORQUE SPECIFICATIONS SEE DWG NO. 128783-01-000

FOR ELECTRICAL CALLOUTS SEE DWG NO. 121339-01-000

DESCRIPTION:
WIRING INSTL-EXTERIOR LAMPS

SHEET: 1 OF 2 ITEM/PART NO: 000181233 / 30112001000 REV

8 7 6 5 4 3 2 1

8 7 6 5 4 3 2 1

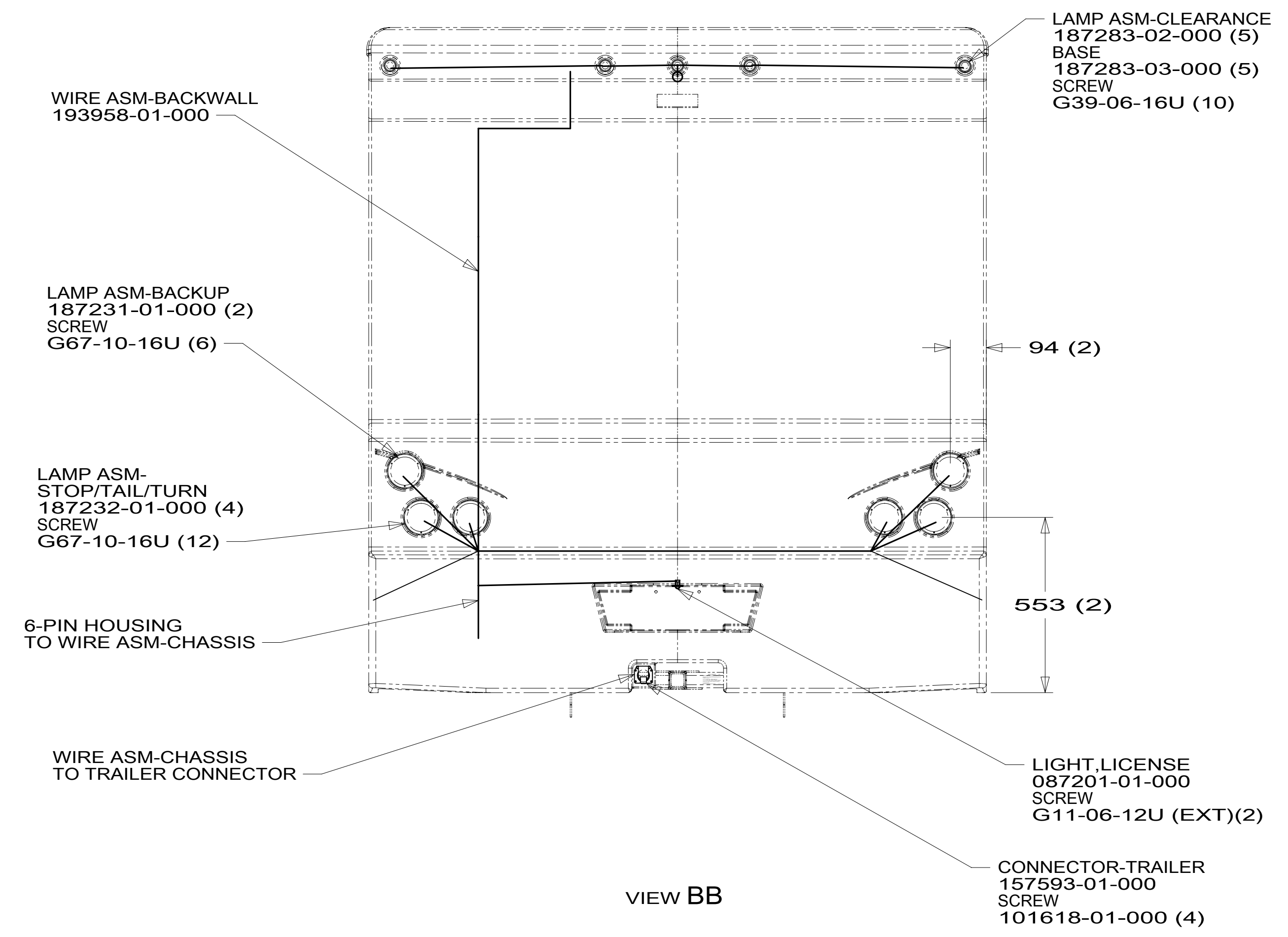
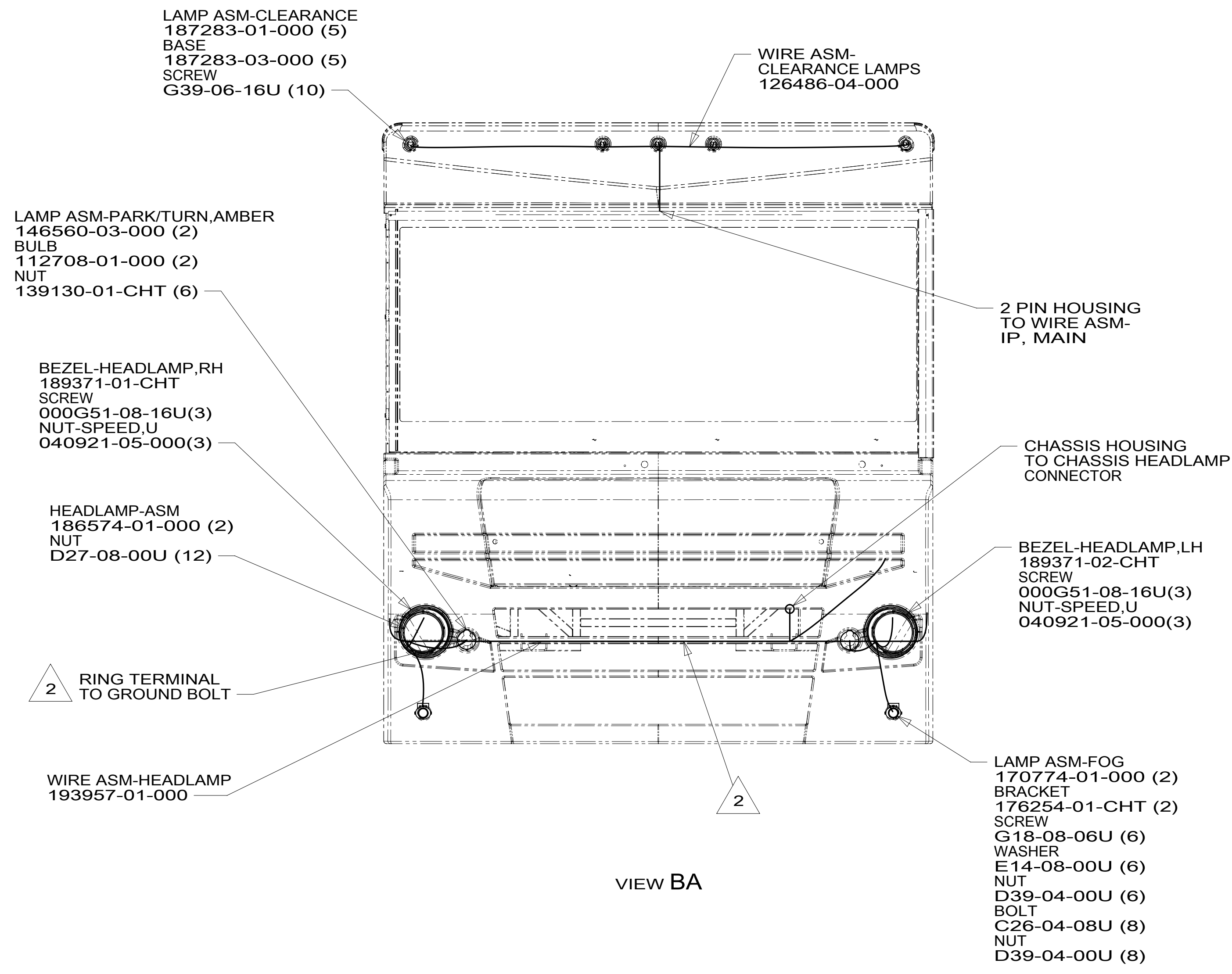

2 CLEAN PAINT OFF METAL (BOLT) BEFORE CONNECTING GROUND TO INSURE CONTACT. ALSO MOUNT CHASSIS SUPPLIED HORN TO GROUND BOLT.

1. GATHER ALL EXCESS WIRE AFTER MAKING ALL CONNECTIONS AND BUNDLE AND SECURE WITH TIE-WIRE 8343-01-000 OR 93147-01-000.

NOTES:

265 CODES/STANDARDS-CSA/CMVSS
1B1 CODES/STANDARDS USA

FOR ELECTRICAL TORQUE SPECIFICATIONS SEE DWG NO. 128783-01-000

FOR ELECTRICAL CALLOUTS SEE DWG NO. 121339-01-000

DESCRIPTION:	1B1 265	
WIRING INSTL-EXTERIOR LAMPS		
SHEET:	ITEM/PART NO.:	REV
2 OF 2	000181233 / 30112001000	

8 7 6 5 4 3 2 1 20-Sep-2016