

- 8. ALL CRIMP FITTINGS TO 1/2" PEX TUBING REQUIRE 1/2" CLAMP 140171-03-000.
- 7. ALL CRIMP FITTINGS TO 5/8" PEX TUBING REQUIRE 5/8" CLAMP 140171-04-000.
- 6. LABEL HOT AND COLD SUPPLY TUBES AND TAPE FITTING TO TUBE BEFORE CABINET SET TO PREVENT MOVEMENT.
- 5. ADD PIPE WRAP (LADDER SCRAP 110157-02-000) INSULATION.
- 4. ADD TEFLON TAPE 010405-02-000.
- 3. ALL TUBING TO BE SECURED AT 1200 INTERVALS MAXIMUM WITH CLAMP 010495-01-000 AND SCREW 000G67-10-12U OR EQUIVALENT.
- 2. TUBING TO BE INSTALLED WITH SUFFICIENT SLOPE TO PROVIDE DRAINAGE TO NEAREST VALVE.
- 1. PLASTIC FITTINGS TO BE SEALED WITH SEALANT 084456-01-000.

NOTES:

- 29B WATER PURIFIER
- 53E WATER SYS WINTERIZATION PKG
- 64R EXTERIOR WASH STATION



UNSPECIFIED TOLERANCES:		MATERIAL:	
WHOLE DIM (X)	3		
ONE-PLACE (X.X)	1.5		
TWO-PLACE (X.XX)	0.50		
ANGLE	1°		
REFER TO ES0018 FOR FASTENER TIGHTENING GUIDELINES		WEIGHT: (LBS)	FIRST USED: (REF)

X-X
FOR WATER CALLOUTS SEE DWG NO. 116230-01-000

DESCRIPTION: WATER SYSTEM INSTL		
SHEET: 1 OF 3	ITEM/PART NO: 000180943 / 30094801000	REV:

300948

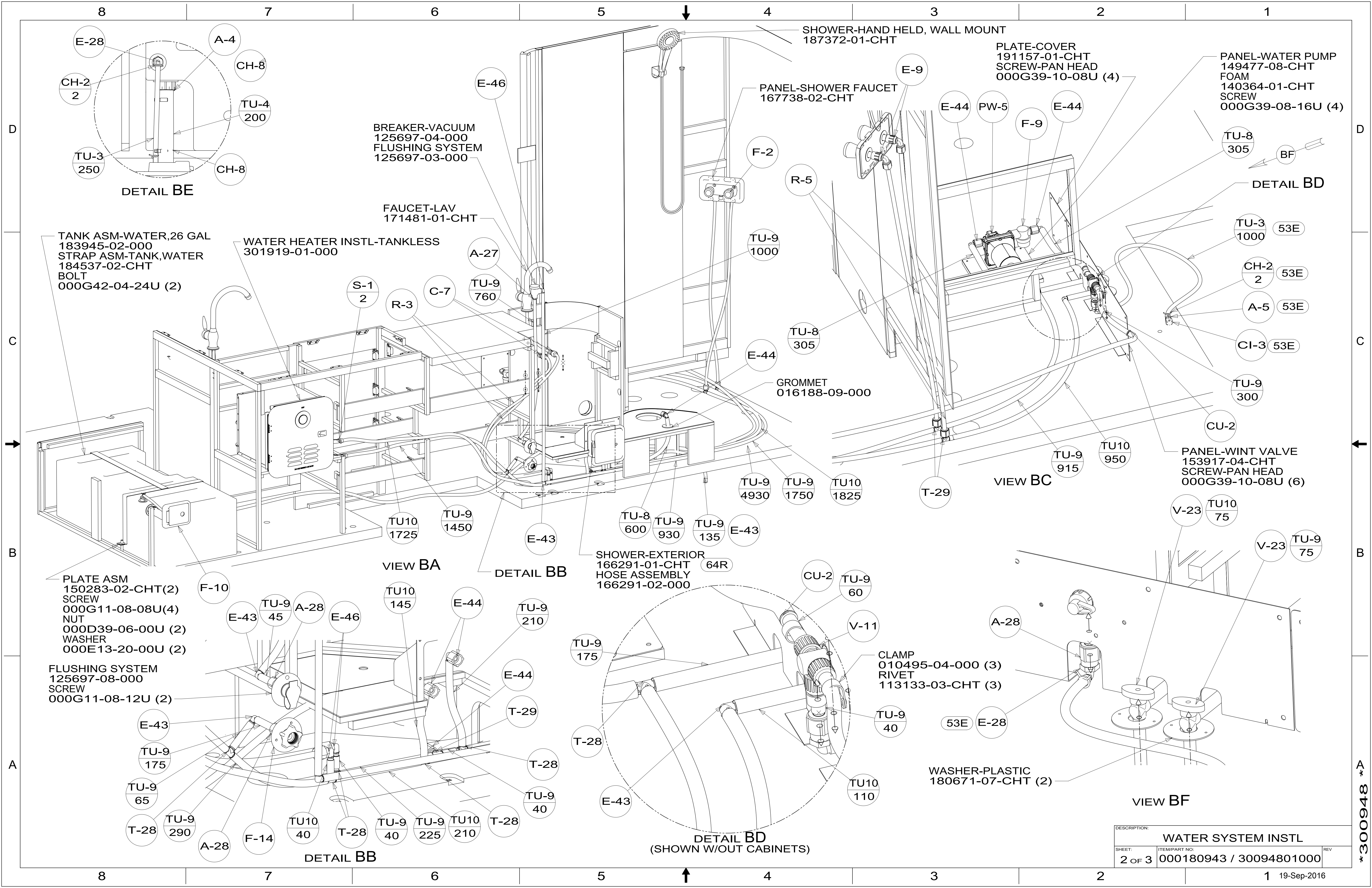

DESCRIPTION:		
WATER SYSTEM INSTL		
SHEET:	ITEM/PART NO.:	REV:
2 OF 3	000180943 / 30094801000	

*300948

8 7 6 5 4 3 2 1

FAUCET-GAL
171482-02-CHT

DETAIL CD

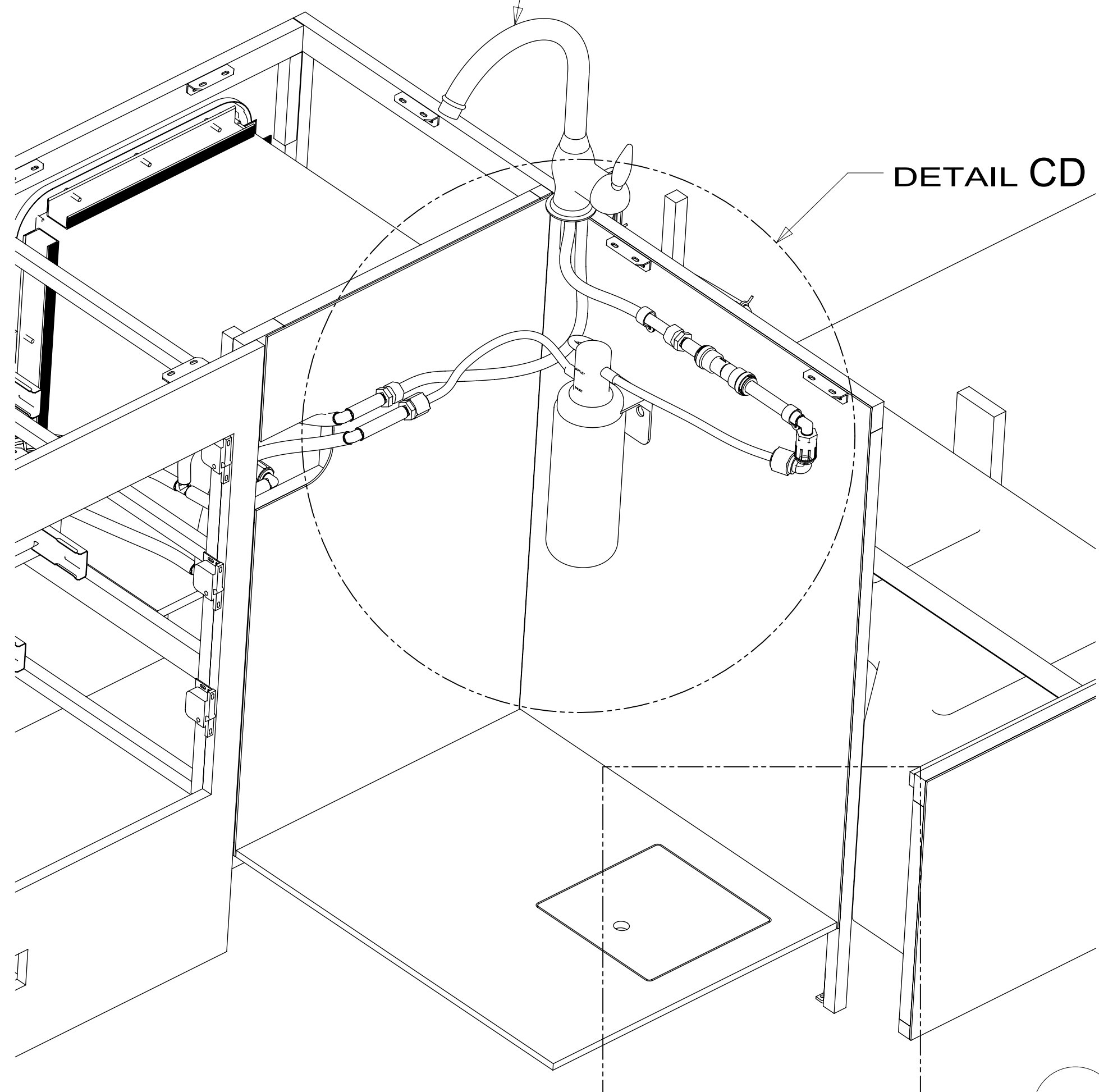

DETAIL CC

VIEW CA

FILTER KIT-WATER, SINK
160946-03-000

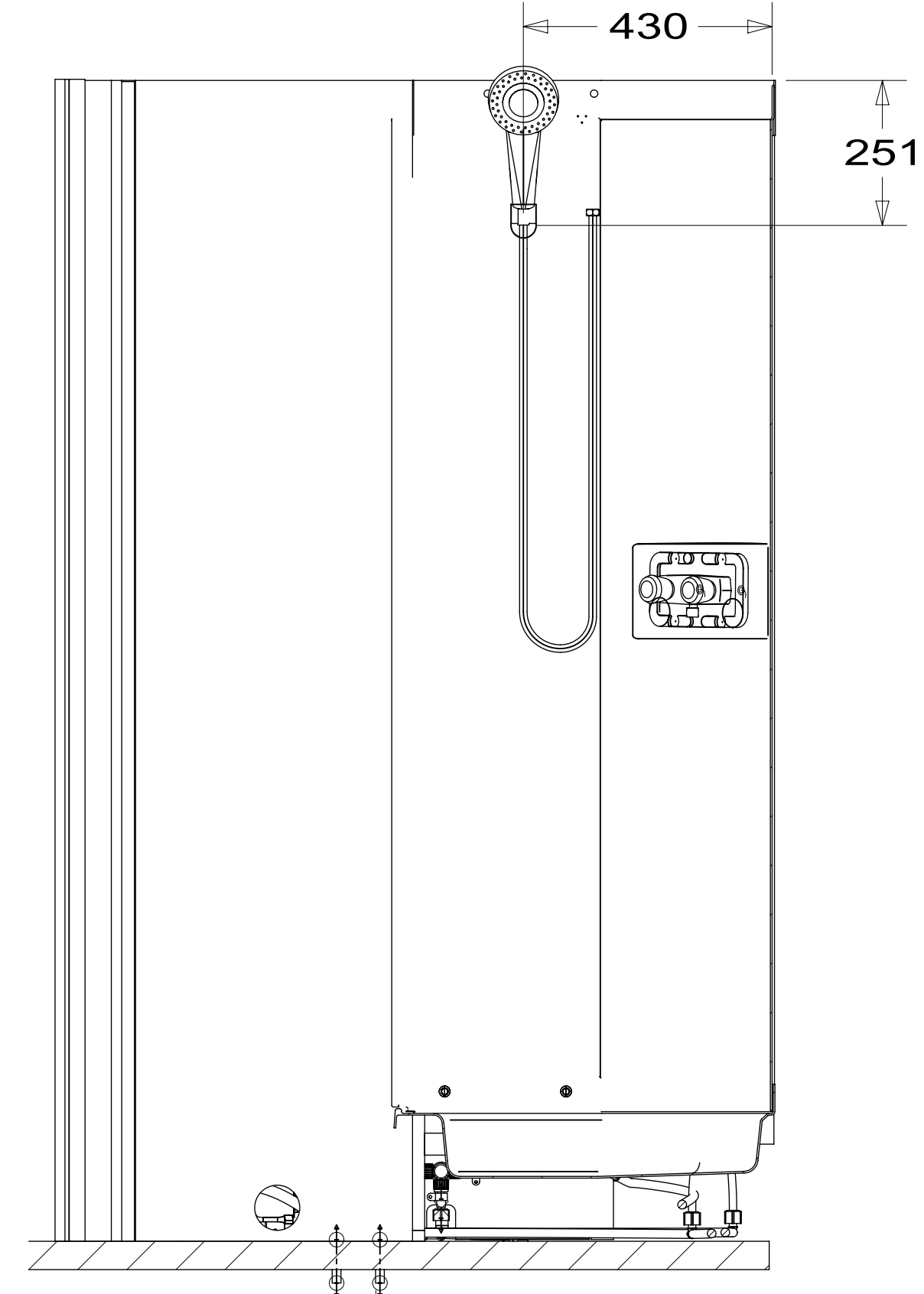

SECTION CE-CE

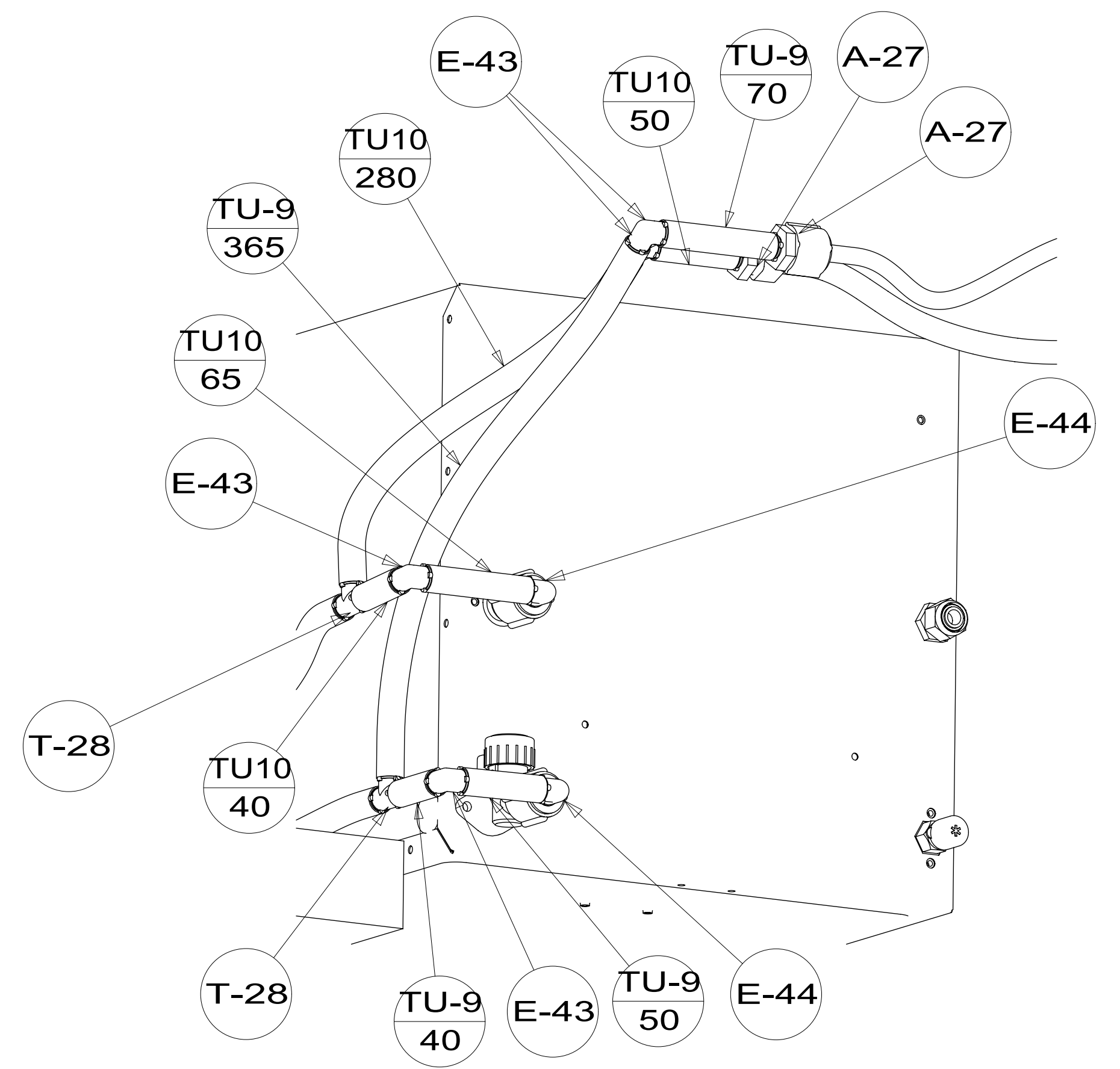

VIEW CB
(SHOWN W/OUT CABINETS)

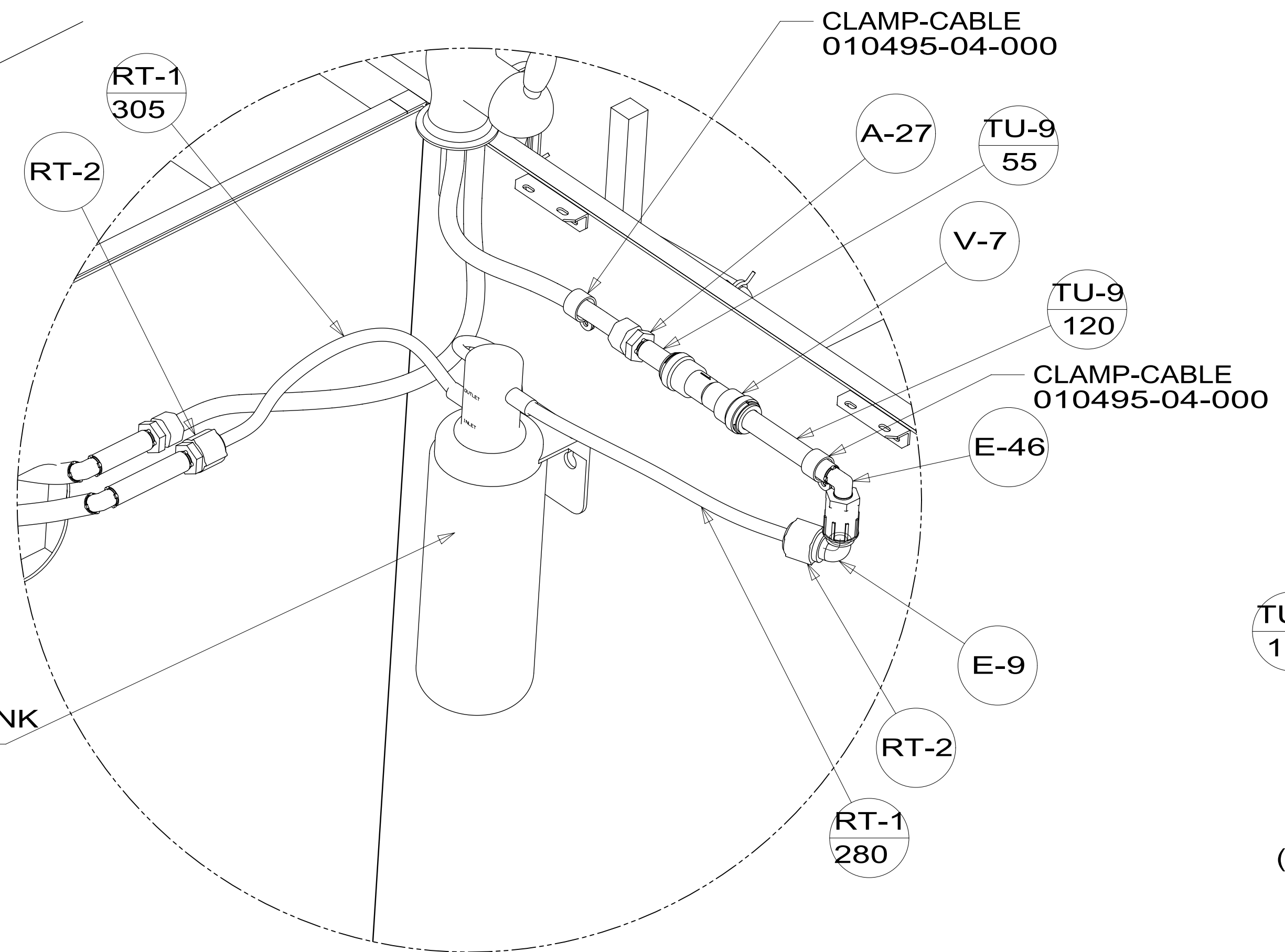

DETAIL CD
29B

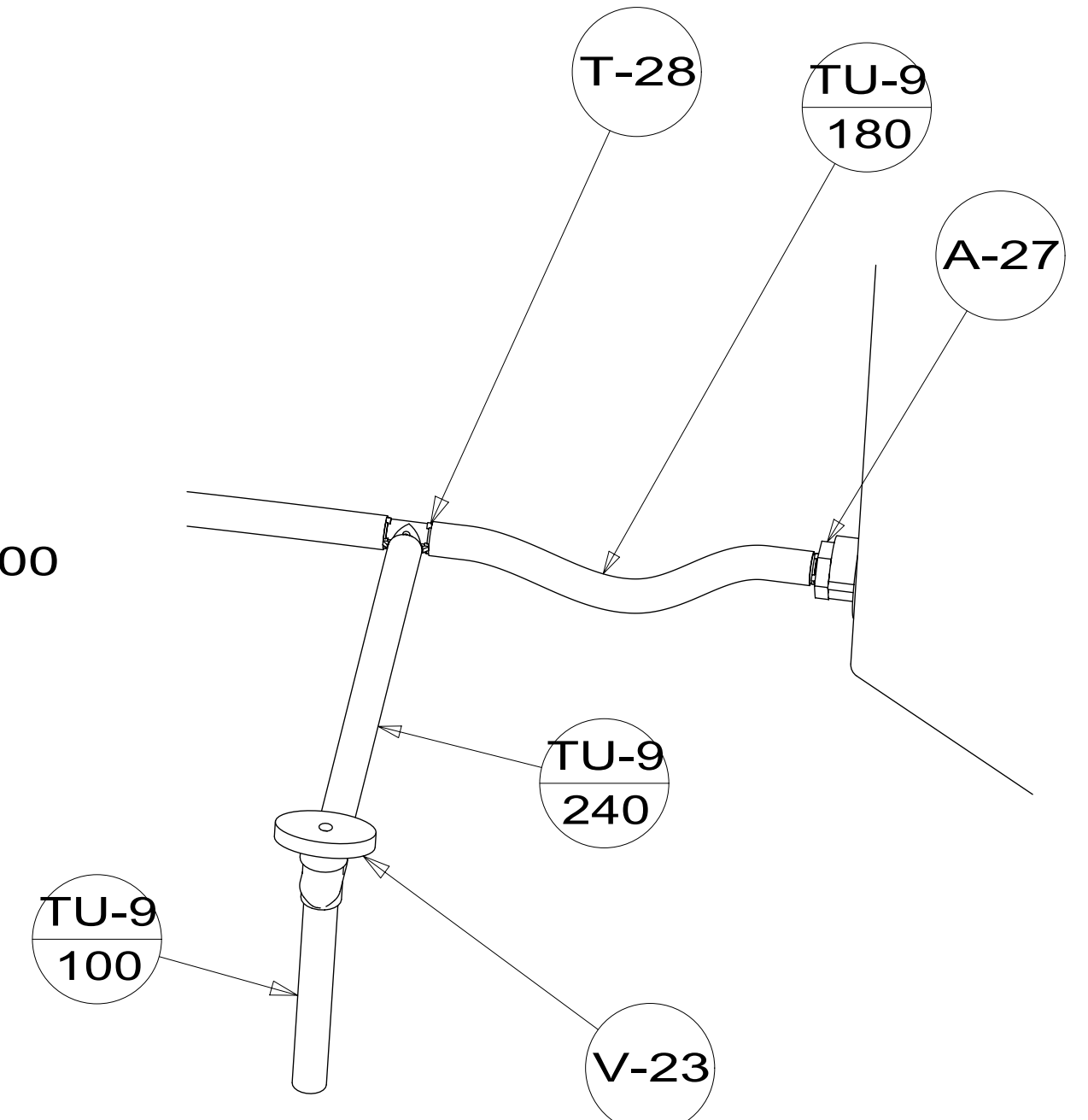

DETAIL CC
(SHOWN W/OUT CABINETS & FLOOR)

DESCRIPTION:		
WATER SYSTEM INSTL		
SHEET:	ITEM/PART NO.:	REV
3 OF 3	000180943 / 30094801000	

8 7 6 5 4 3 2 1 19-Sep-2016

300948