

- 10. FASTEN PLATFORM TO FLOOR AFTER SIDEWALL IS SET AND HEATER IS ATTACHED TO WALL.
- 9. ALL CRIMP FITTINGS TO 3/4" PEX TUBING REQUIRE 3/4" CLAMP 140171-05-000.
- 8. ALL CRIMP FITTINGS TO 1/2" PEX TUBING REQUIRE 1/2" CLAMP 140171-03-000.
- 7. ALL CRIMP FITTINGS TO 5/8" FLEX TUBING REQUIRE 5/8" CLAMP 140171-04-000.
- 6. LABEL HOT AND COLD SUPPLY TUBES AND TAPE FITTING TO TUBE BEFORE CABINET SET TO PREVENT MOVEMENT.
- 5. ADD PIPE WRAP (LADDER SCRAP 110157-02-000) INSULATION.
- 4. ADD TEFLON TAPE 010405-02-000.
- 3. ALL TUBING TO BE SECURED AT 1200 INTERVALS MAXIMUM WITH CLAMP 010495-01-000 AND SCREW 000G67-10-12U OR EQUIVALENT.
- 2. TUBING TO BE INSTALLED WITH SUFFICIENT SLOPE TO PROVIDE DRAINAGE TO NEAREST VALVE.
- 1. PLASTIC FITTINGS TO BE SEALED WITH SEALANT 084456-01-000.

NOTES:

X-X
 FOR WATER CALLOUTS SEE DWG NO. 000209446 / 303369-01-000

WINNEBAGO[®]		COPYRIGHT 2017 WINNEBAGO INDUSTRIES, INC.	
DSNR:		ALL DIMENSIONS ARE IN MILLIMETERS	
DIFTR:		MATERIAL:	
UNSPECIFIED TOLERANCES:			
WHOLE DIM (X)	3		
ONE-PLACE (X.X)	1.5		
TWO-PLACE (X.XX)	0.50		
ANGLE	1°		
REFER TO ES0018 FOR FASTENER TIGHTENING GUIDELINES	WEIGHT: (LBS)	FIRST USED: (REF)	16 E31KE
DESCRIPTION: WATER SYSTEM INSTL			
SHEET: 1 OF 3	ITEM/PART NO: 000180191 / 30048501000	REV:	

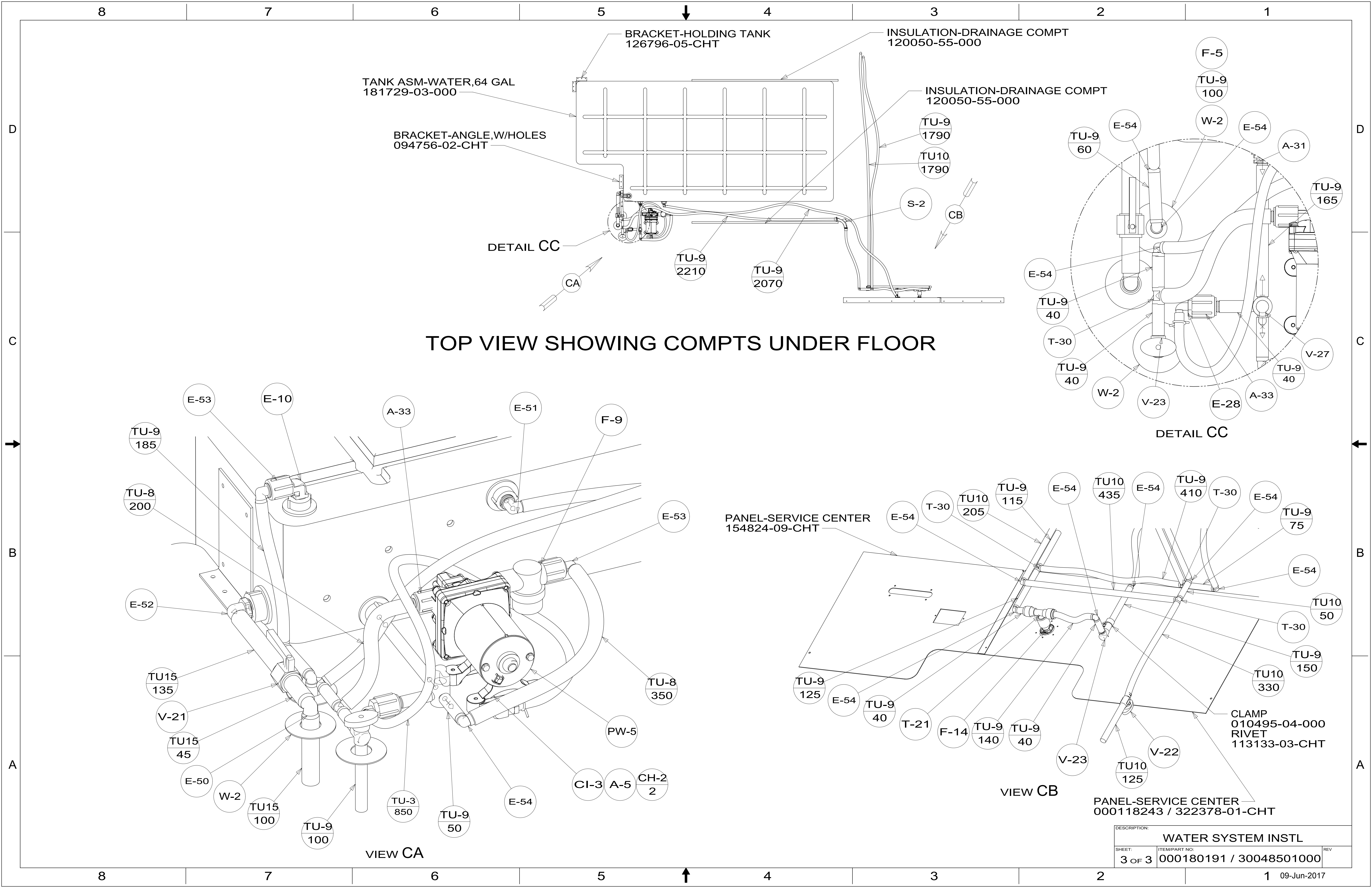

TOP VIEW SHOWING COMPTS UNDER FLOOR

DESCRIPTION:		
WATER SYSTEM INSTL		
SHEET:	ITEM/PART NO:	REV
3 OF 3	000180191 / 30048501000	