

VIEW AA

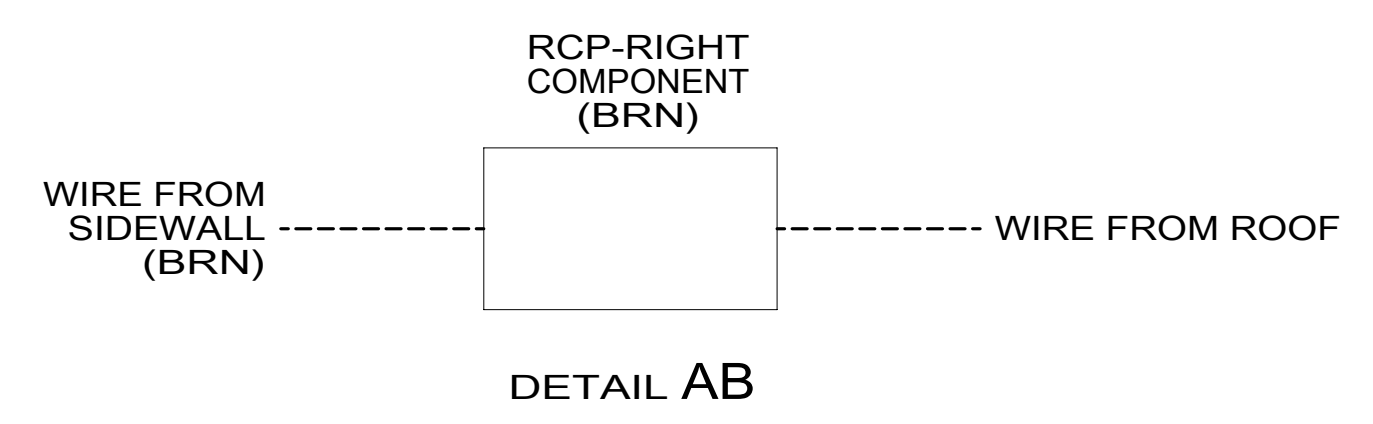

DETAIL AB

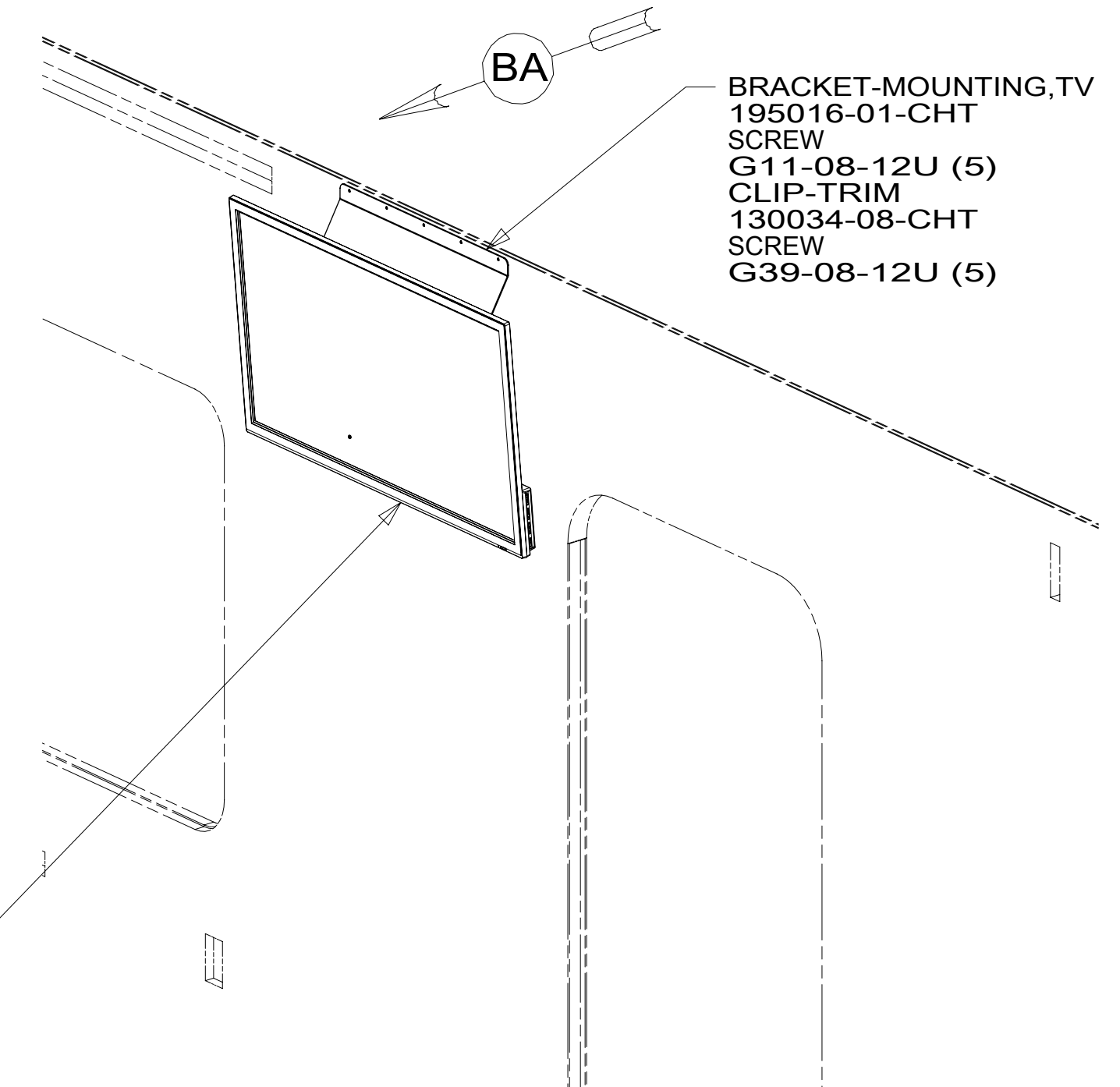

VIEW BA

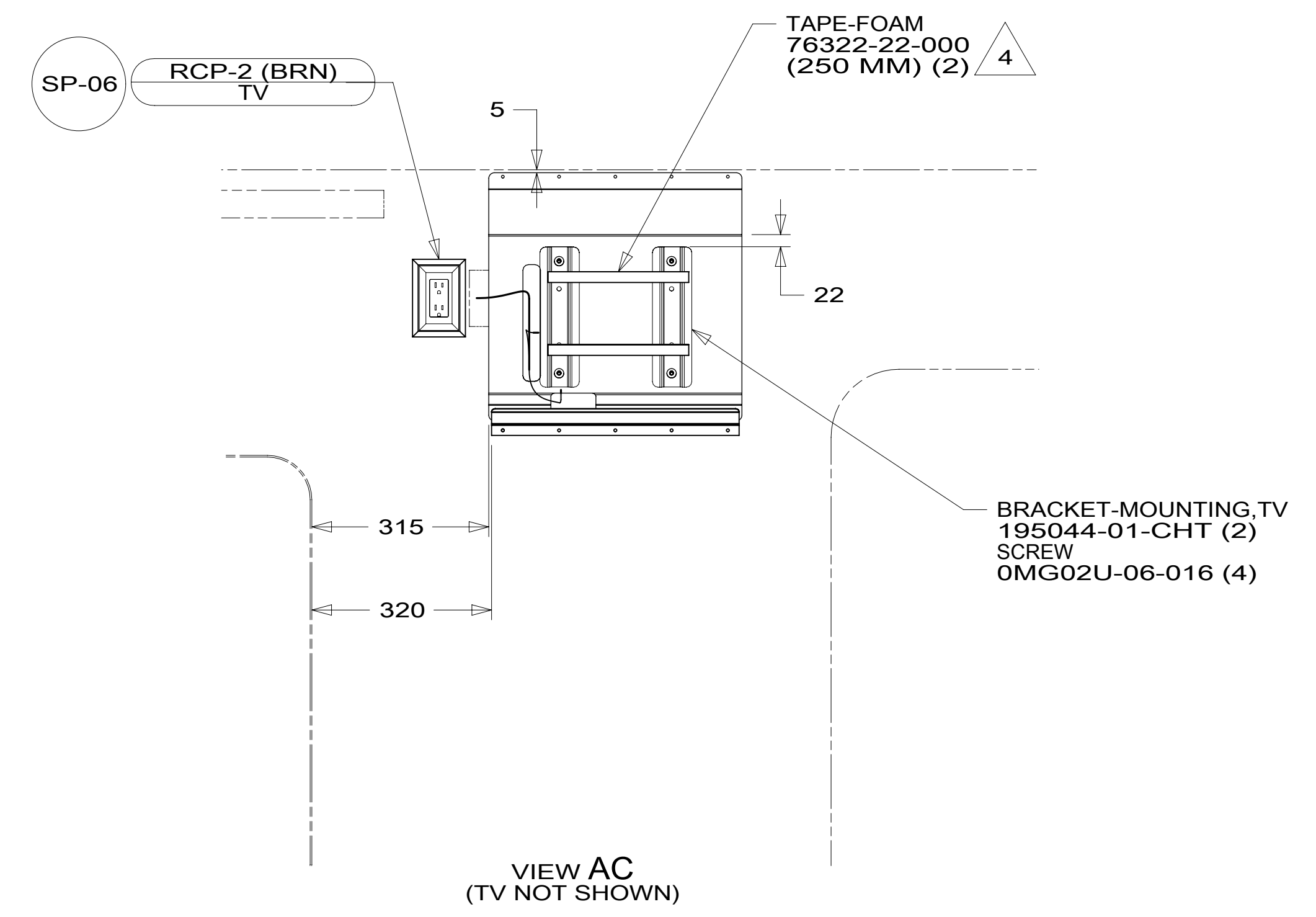

VIEW AC (TV NOT SHOWN)

- NOTES:
- 4 PREP SURFACE WITH 87211-01-000.
 - 3. WHERE WIRES PASS THROUGH HOLES IN STEEL AND NOT OTHERWISE PROTECTED, USE GROMMET 92908-02-000.
 - 2. ALL WIRES TO BE SECURED WITH CLAMP 10495-01-000 OR CLIP 80734-01-000 EVERY 600MM. USE SCREW G67-10-12B UNLESS OTHERWISE SPECIFIED.
 - 1. 110V WIRE TO BE CLAMPED WITH CLAMP 10497-05-000 WITHIN 200MM OF OUTLET BOXES, USE SCREW G67-10-12B.

FOR ELECTRICAL TORQUE SPECIFICATIONS SEE DWG NO. 128783-01-000

FOR ELECTRICAL CALLOUTS SEE DWG NO. 121339-01-000

- 68Y TV - MAIN
- 265 CODES/STANDARDS-CSA/CMVSS
- 1B1 CODES/STANDARDS USA

1B1 265 68Y



DSNR:		ALL DIMENSIONS ARE IN MILLIMETERS	
DFFR:		MATERIAL:	
UNSPECIFIED TOLERANCES:			
WHOLE DIM (X)	3		
ONE-PLACE (X.X)	1.5		
TWO-PLACE (X.XX)	0.50		
ANGLE	1°		
REFER TO ES0018 FOR FASTENER TIGHTENING GUIDELINES		WEIGHT: (LBS)	FIRST USED:
DESCRIPTION: WIRING INSTL-TV/DVD			
SHEET: 1 OF 2	ITEM/PART NO: 000180173 / 30044501000	REV	

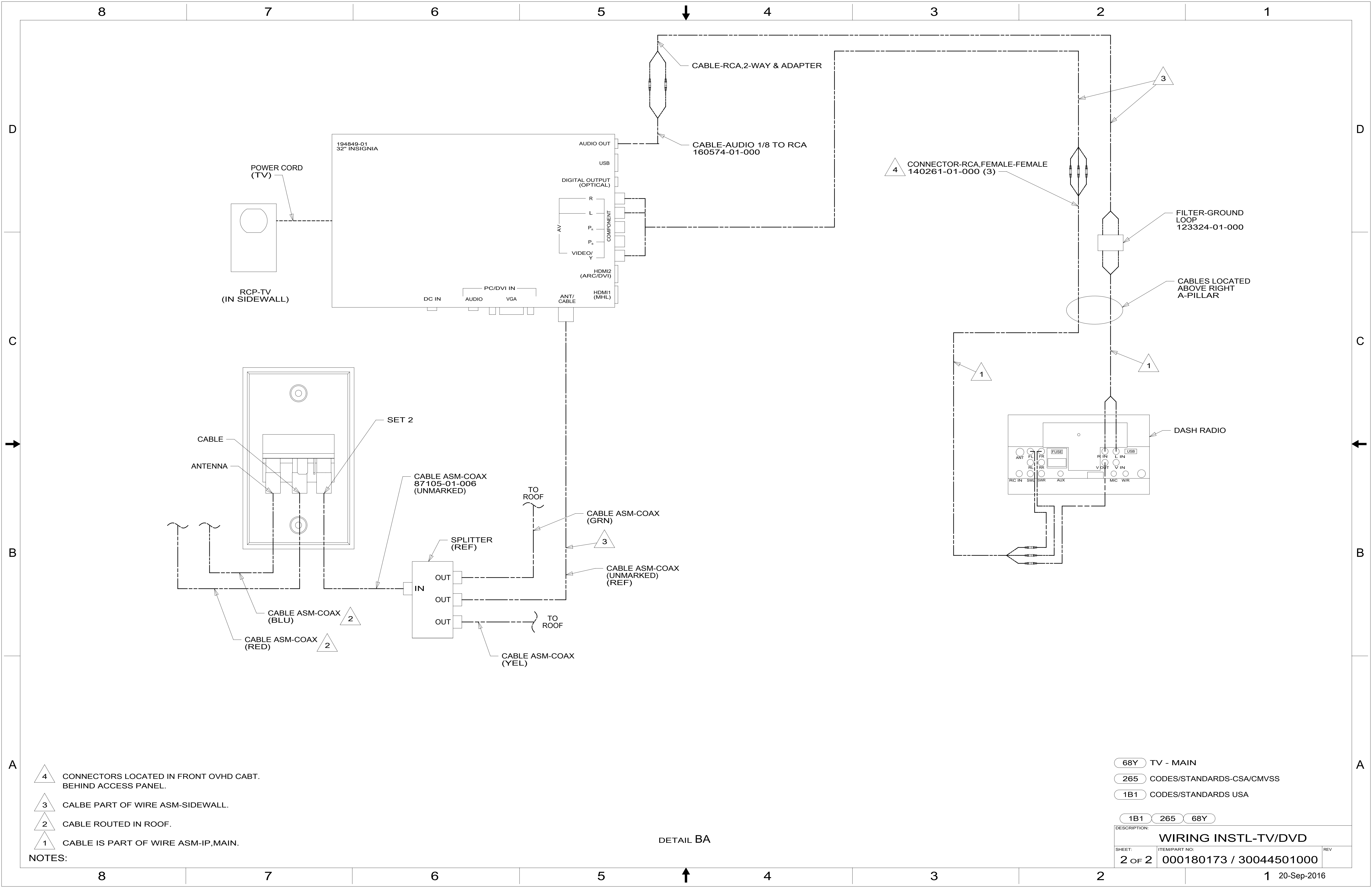

- NOTES:
- 4 CONNECTORS LOCATED IN FRONT OVHD CABT. BEHIND ACCESS PANEL.
 - 3 CALBE PART OF WIRE ASM-SIDEWALL.
 - 2 CABLE ROUTED IN ROOF.
 - 1 CABLE IS PART OF WIRE ASM-IP,MAIN.

68Y	TV - MAIN	
265	CODES/STANDARDS-CSA/CMVSS	
1B1	CODES/STANDARDS USA	
1B1	265	68Y
DESCRIPTION: WIRING INSTL-TV/DVD		
SHEET: 2 OF 2	ITEM/PART NO: 000180173 / 30044501000	REV

DETAIL BA