

REV	ZONE	REVISION RECORD	DATE	DFTR-ORIG
A	---	INITIAL RELEASE	10/15/15	3650-3660
B	S3D5	REPLACE SPACER 130041-05 WITH -03, REPLACE SCREWS 000G11 WITH 000G39	11/12/15	3660
C	---	MOVE SHOWERHEAD DOWN	1-28-16	1600-5472
D	---	SHT2 CHG LENGTHS	8-5-16	1600-2314
E	---	LENGTH CHG SHT2	9-14-16	1600-5472
F	ALL	FITTINGS CHANGE, VARIOUS LENGTH CHANGES, PANEL-SIDE CHANGE	09/28/16	3650
G	SHT2	CHANGED FILTER	12-21-16	0626-1600
H	SHT4	SH-2 WAS SH-1 AND CHG PANEL	06/05/17	9080-1600
J	SHT3	CHG FAUCET AND TRIM KIT	09/05/17	9080-1600

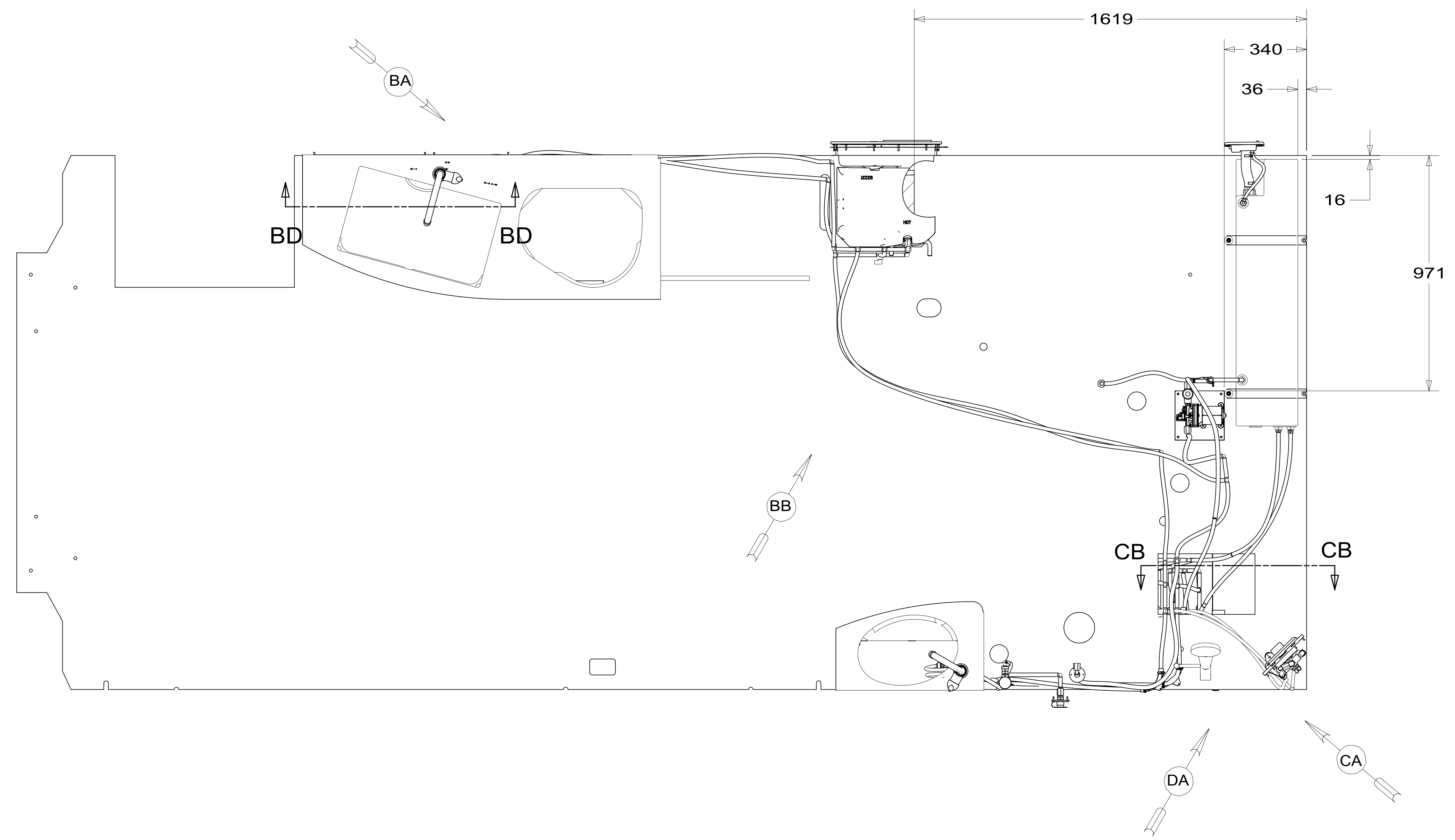

- 10. LAVATORY FAUCET SPOUT TO BE TURNED 180 DEGREES SO THE ON/OFF HANDLE IS FACING TOWARD THE CENTER OF THE COACH.
- 9. INSTALL BYPASS PLUG FOR SYSTEM TESTING AND SHIPPING.
- 8. ALL CRIMP FITTINGS TO 1/2" PEX TUBING REQUIRE 1/2" CLAMP 140171-03-000.
- 7. ALL CRIMP FITTINGS TO 5/8" PEX TUBING REQUIRE 5/8" CLAMP 140171-04-000.
- 6. LABEL HOT AND COLD SUPPLY TUBES AND TAPE FITTING TO TUBE BEFORE CABINET SET TO PREVENT MOVEMENT.
- 5. ADD PIPE WRAP (LADDER SCRAP 110157-02-000) INSULATION.
- 4. ADD TEFLON TAPE 010405-02-000.
- 3. ALL TUBING TO BE SECURED AT 1200 INTERVALS MAXIMUM WITH CLAMP 010495-01-000 AND SCREW 000G67-10-12U OR EQUIVALENT.
- 2. TUBING TO BE INSTALLED WITH SUFFICIENT SLOPE TO PROVIDE DRAINAGE TO NEAREST VALVE.
- 1. PLASTIC FITTINGS TO BE SEALED WITH SEALANT 084456-01-000.

53B WTR HTR-6 GAL ELEC/LP/GAS
29B WATER PURIFIER

WINNEBAGO
COPYRIGHT 2017 WINNEBAGO INDUSTRIES, INC.

DSNR:		ALL DIMENSIONS ARE IN MILLIMETERS	
DFTR:			
UNSPECIFIED TOLERANCES:		MATERIAL:	
WHOLE DIM (X)	3		
ONE-PLACE (X.X)	1.5		
TWO-PLACE (X.XX)	0.50		
ANGLE	1°		
REFER TO ES0018 FOR FASTENER TIGHTENING GUIDELINES		WEIGHT: (LBS)	FIRST USED: (REF)
			16 524J
DESCRIPTION: WATER SYSTEM INSTL			
SHEET:	ITEM/PART NO.:	REV	
1 OF 4	000180026 / 30086901000		

X-X
FOR WATER CALLOUTS SEE DWG NO. 000209446 / 303369-01-000

300869A

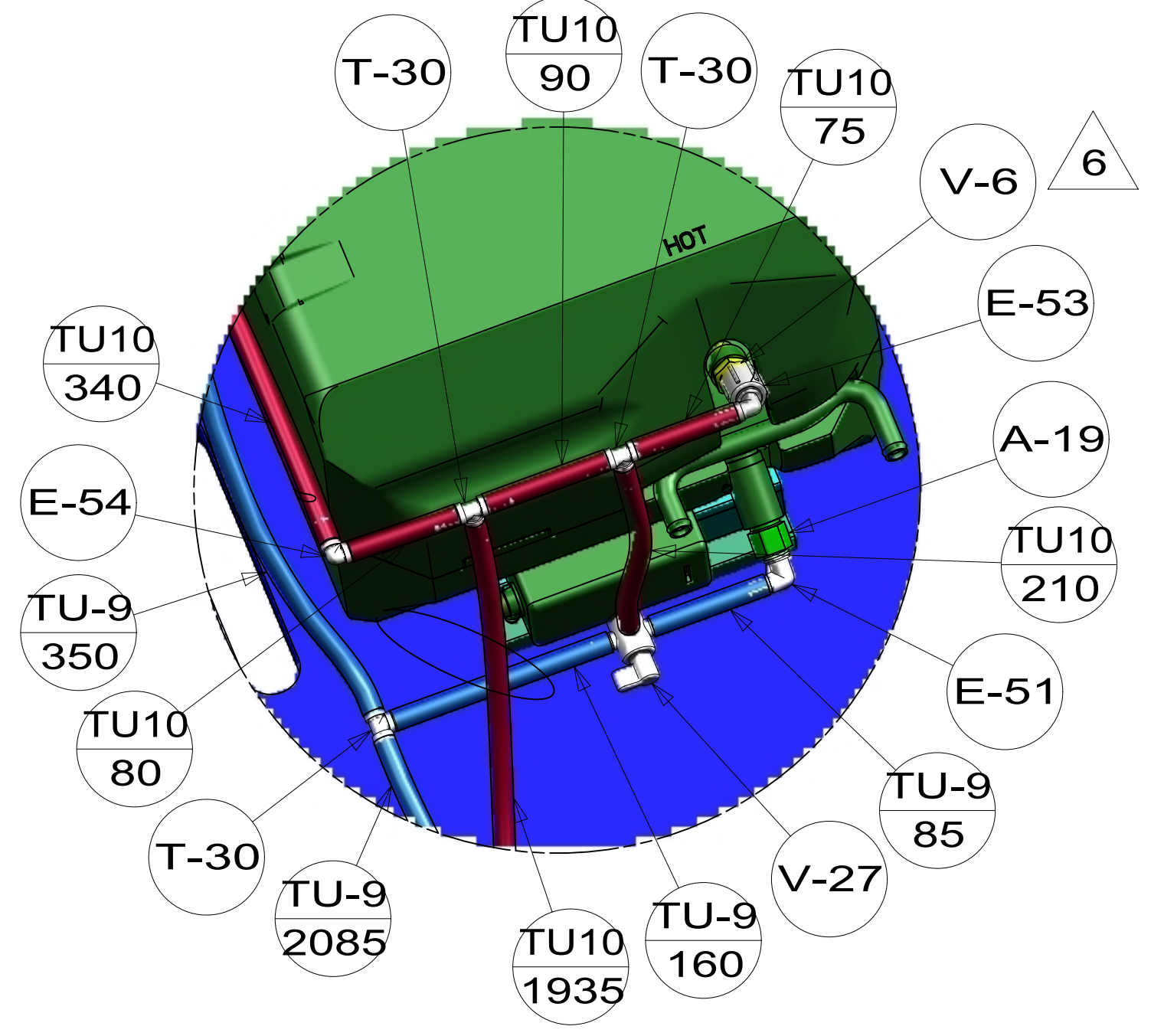

DETAIL BC
(SHOWN W/OUT CABINETS)

- STRAP-TANK,WATER
118994-26-CHT (2)
- SCREW
000G42-04-24U (2)
- WASHER
000E13-16-00U (2)
- SCREW
000G39-10-08U(2)
- NUT
000D39-05-00U(2)
- WASHER
000E13-22-00U(2)

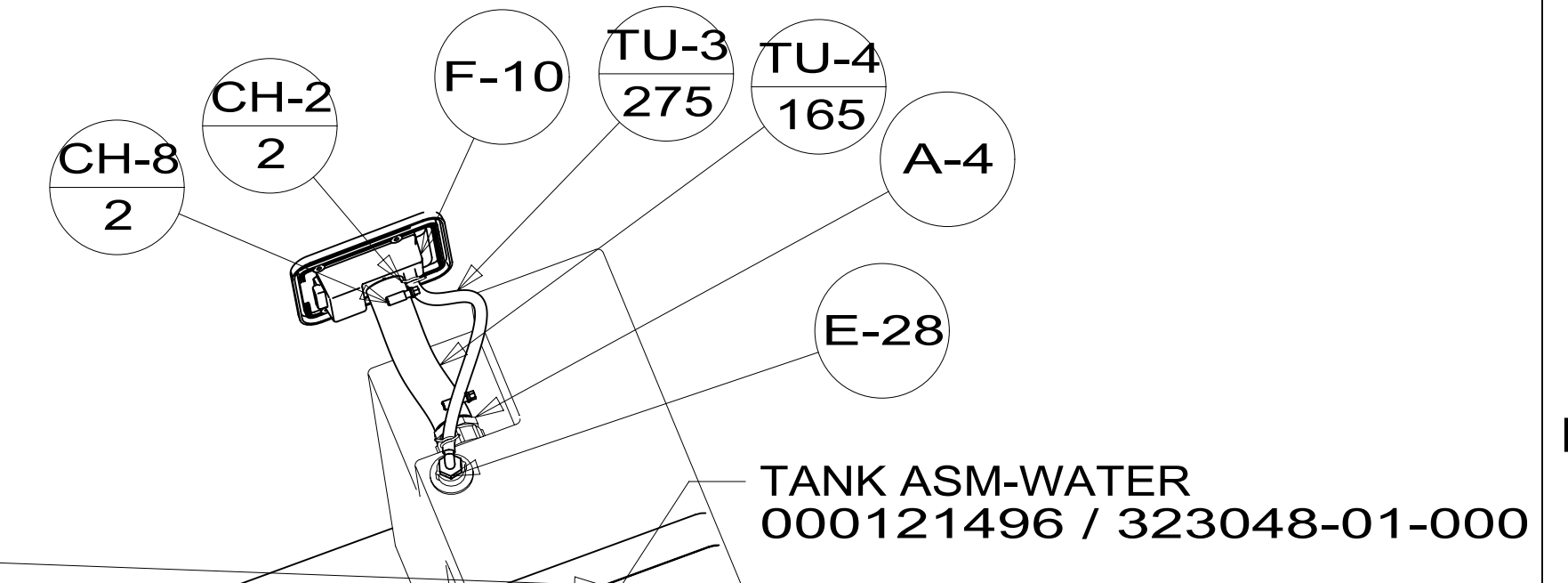

DETAIL CC

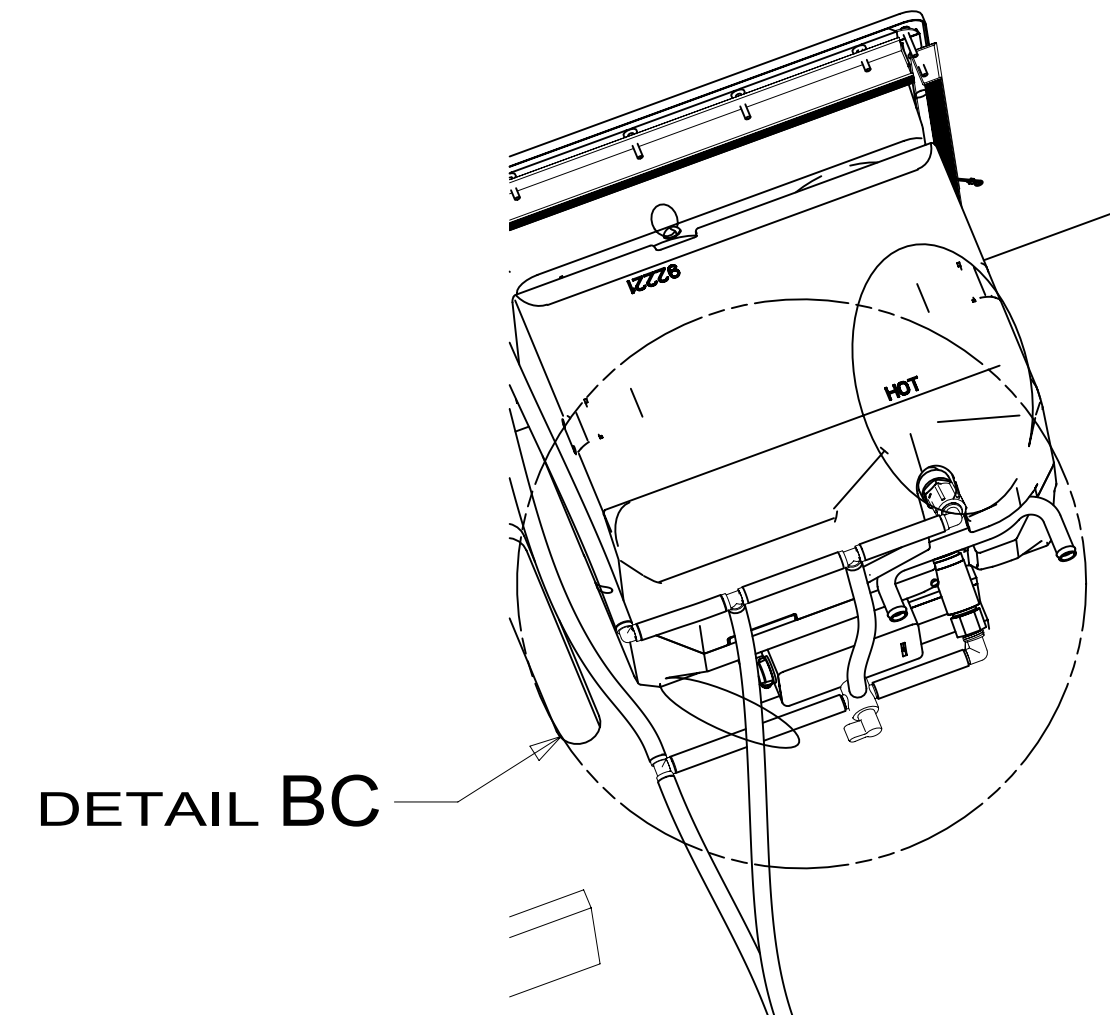

DETAIL BC

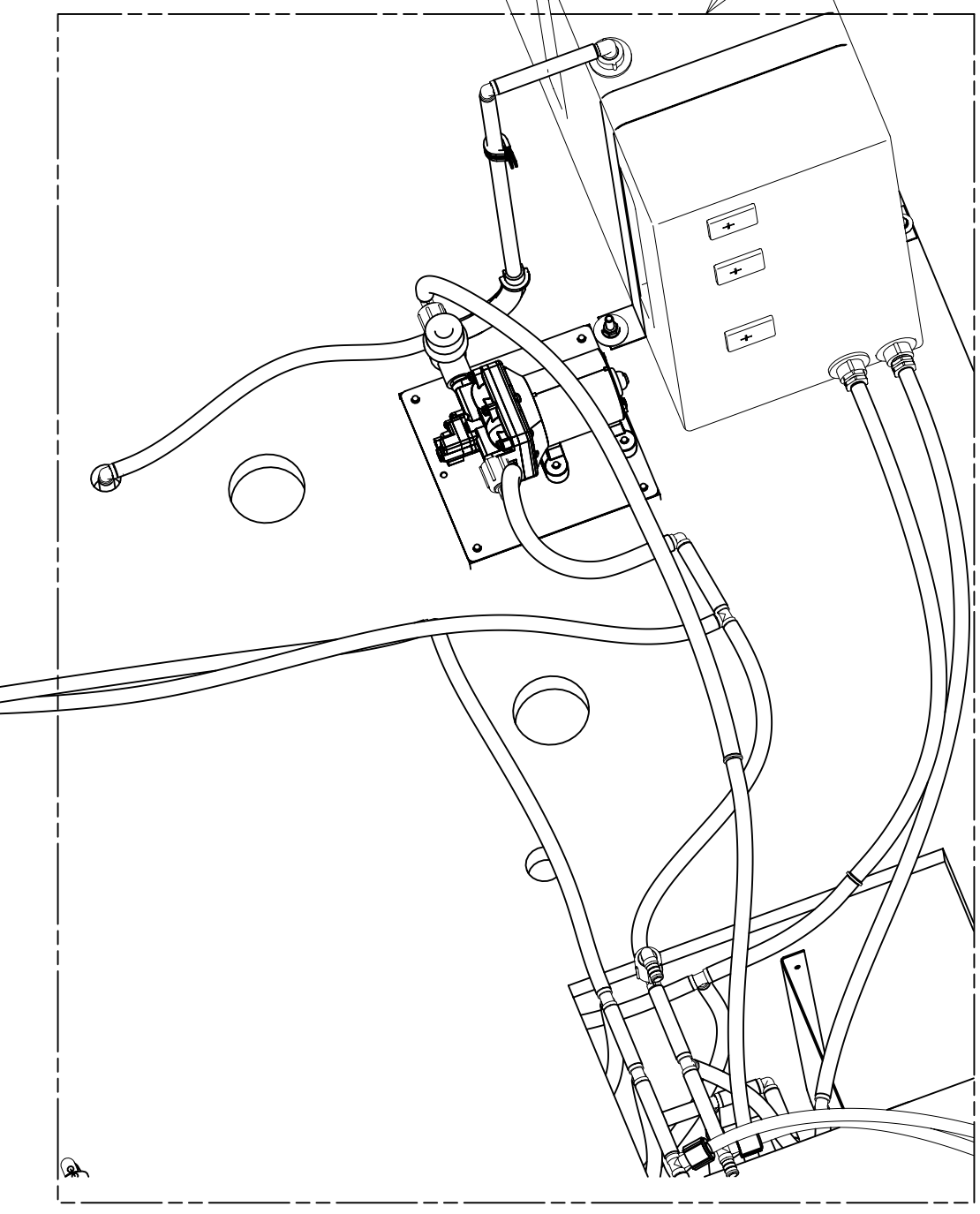

VIEW BB

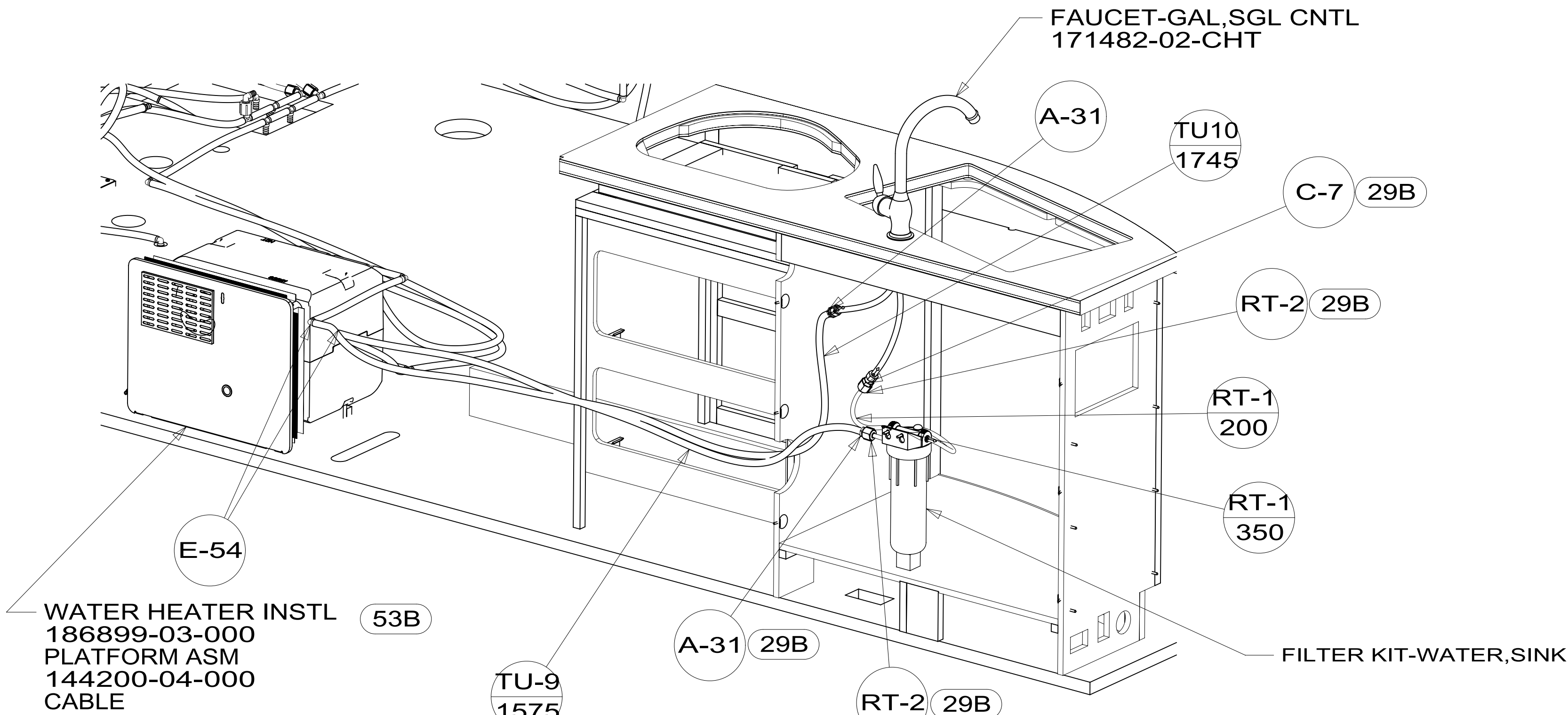

VIEW BA

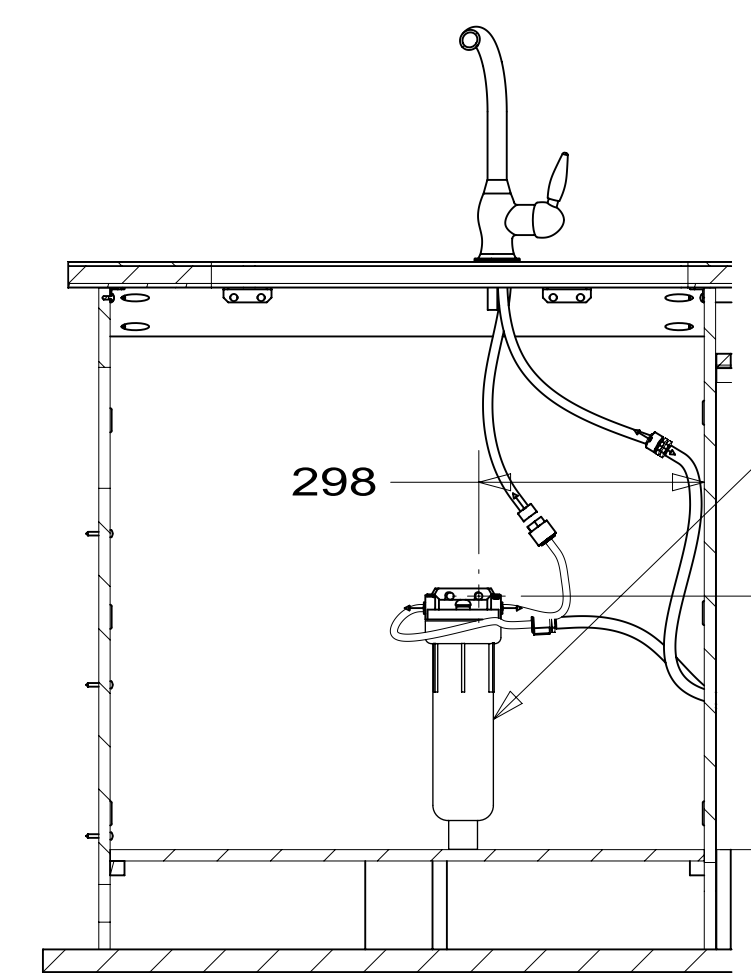

SECTION BD-BD

- WATER HEATER INSTL
186899-03-000
- PLATFORM ASM
144200-04-000
- CABLE
076767-03-000
- SCREW
000G39-08-08U (2)

- FILTER KIT-WATER,SINK
000038865 / 318913-01-000
- SCREW
000G67-10-12U (2)

DESCRIPTION: WATER SYSTEM INSTL		
SHEET: 2 OF 4	ITEM/PART NO: 000180026 / 30086901000	REV

*300869

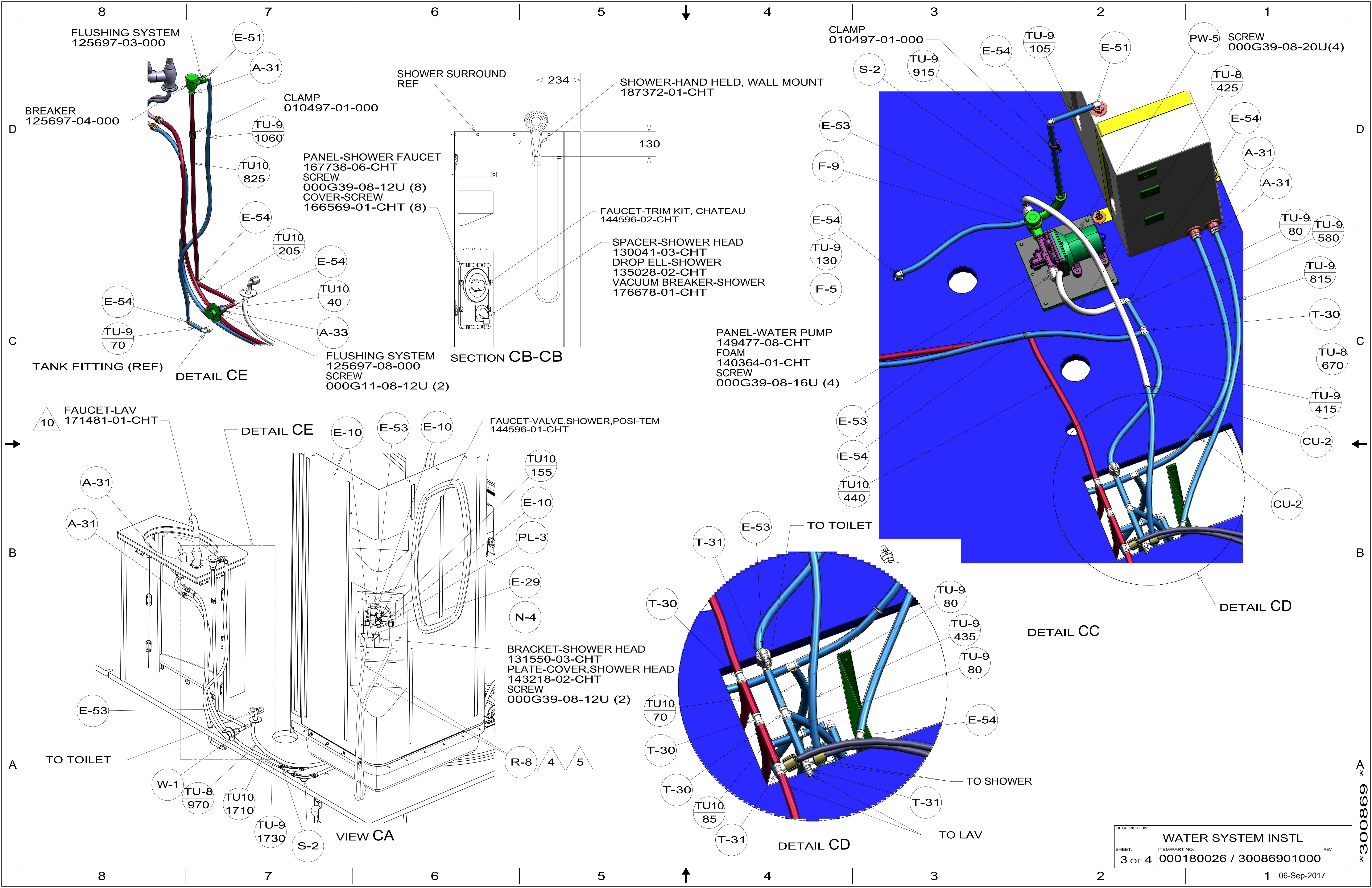

FLUSHING SYSTEM
125697-03-000

BREAKER
125697-04-000

SHOWER SURROUND
REF

SHOWER-HAND HELD, WALL MOUNT
187372-01-CHT

CLAMP
010497-01-000

TU-9
105

PW-5 SCREW
000G39-08-20U(4)

CLAMP
010497-01-000

PANEL-SHOWER FAUCET
167738-06-CHT
SCREW
000G39-08-12U (8)
COVER-SCREW
166569-01-CHT (8)

FAUCET-TRIM KIT, CHATEAU
144596-02-CHT

SPACER-SHOWER HEAD
130041-03-CHT
DROP ELL-SHOWER
135028-02-CHT
VACUUM BREAKER-SHOWER
176678-01-CHT

PANEL-WATER PUMP
149477-08-CHT
FOAM
140364-01-CHT
SCREW
000G39-08-16U (4)

FLUSHING SYSTEM
125697-08-000
SCREW
000G11-08-12U (2)

SECTION CB-CB

FAUCET-LAV
171481-01-CHT

FAUCET-VALVE, SHOWER, POSI-TEM
144596-01-CHT

TU10
155

PL-3

E-29

N-4

BRACKET-SHOWER HEAD
131550-03-CHT
PLATE-COVER, SHOWER HEAD
143218-02-CHT
SCREW
000G39-08-12U (2)

TU10
70

T-30

T-30

TU10
85

T-31

TU-9
80

TU-9
435

TU-9
80

E-54

T-30

T-31

DETAIL CC

DETAIL CD

DETAIL CD

VIEW CA

DESCRIPTION:		
WATER SYSTEM INSTL		
SHEET:	ITEM/PART NO.:	REV
3 OF 4	000180026 / 30086901000	

*300869

PANEL-SERVICE CENTER
166877-13-CHT

PANEL-SIDE,COMPARTMENT
000032377 / 317192-01-CHT
SCREW
000G39-10-08U (5)

PANEL-ELECTRICAL
000121181 / 322972-01-CHT

DB

V-23

V-23

SCREW
000G11-08-12U (3)

F-14

VIEW DA

V-23

TU-9
60

E-54

TU-9
40

E-54

TU-9
40

DETAIL DC

T-30

TU-9
60

A-33

E-54

TU-9
125

TU-9
60

DETAIL DC

TU10
430

TU10
240

TU-9
175

T-30

TU-9
400

TU-9
210

TU-9
210

TU-9
200

TU-9
80

E-54

TU-9
155

E-54

TU-9
165

TU-9
100

E-54

TU-9
100

TU10
105

TU10
100

VIEW DB

E-54

TU-9
75

CLAMP
010495-04-000
RIVET
113133-03-CHT

CLAMP
010495-04-000 (2)
RIVET
113133-03-CHT (2)

TU-9
80

E-54

TU-9
210

TU-9
85

E-54

A-33

A-33

A-13

CH-2

A-33

TU-9
120

TU10
125

E-54

CLAMP
010495-04-000 (3)
RIVET
113133-03-CHT (3)

DESCRIPTION: WATER SYSTEM INSTL		
SHEET: 4 OF 4	ITEM/PART NO: 000180026 / 30086901000	REV

A * 300869