

2 SWITCH ON LAMP TO BE ORIENTED TO REAR OF CABINET.

1. AT MINIMUM ALL WIRES TO BE SUPPORTED AND SECURED PER CODE REQUIREMENTS. USE CLAMP 10495 OR 10497 OR WIRE TIE 8343 OR 108046 AND SCREW G67-XX-XXX OR G56-XX-XXX AS APPROPRIATE FOR INSTALLATION.

NOTES:

FOR ELECTRICAL TORQUE SPECIFICATIONS SEE DWG NO. 128783-01-000

FOR ELECTRICAL CALLOUTS SEE DWG NO. 121339-01-000

- 644 GREAT ALASKAN RENTAL PACKAGE
- 265 CODES/STANDARDS-CSA/CMVSS
- 1B1 CODES/STANDARDS USA

1B1 265

WINNEBAGO
COPYRIGHT 2016 WINNEBAGO INDUSTRIES, INC.

DSNR:	ALL DIMENSIONS ARE IN MILLIMETERS
DFFR:	MATERIAL:
UNSPECIFIED TOLERANCES:	WEIGHT: (LBS)
WHOLE DIM (X) : 3	FIRST USED:
ONE-PLACE (X.X) : 1.5	16 331K
TWO-PLACE (X.XX) : 0.50	DESCRIPTION:
ANGLE : 1°	WIRING INSTL-BODY, 12V
REFER TO ES0018 FOR FASTENER TIGHTENING GUIDELINES	SHEET: 1 OF 5
	ITEM/PART NO: 000180019 / 30082201000
	REV: REF: 1 20-Sep-2016

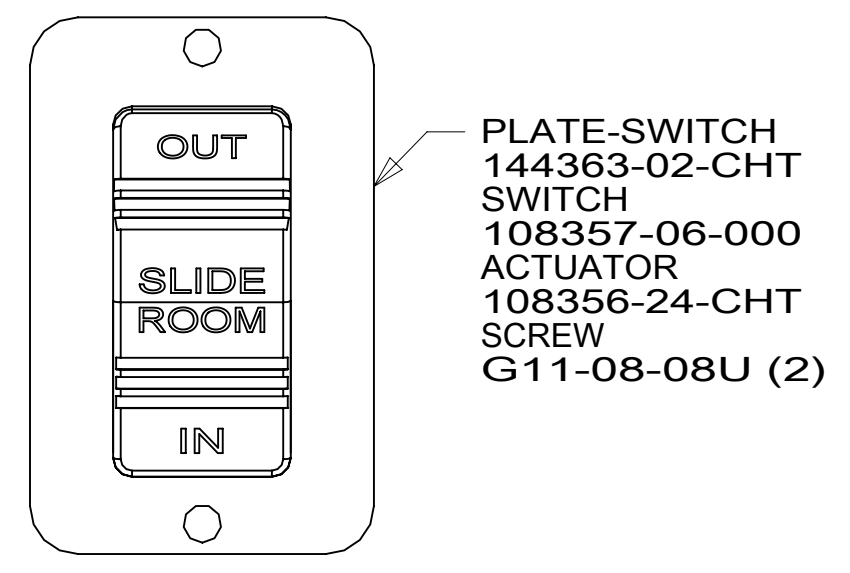
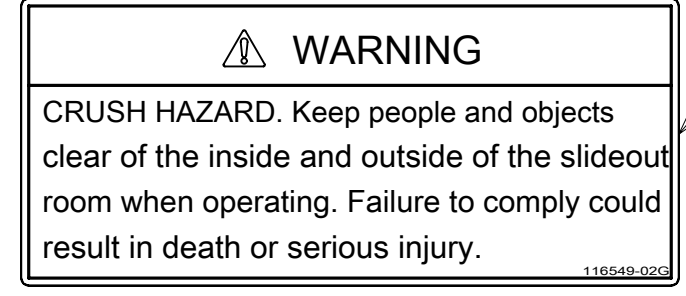
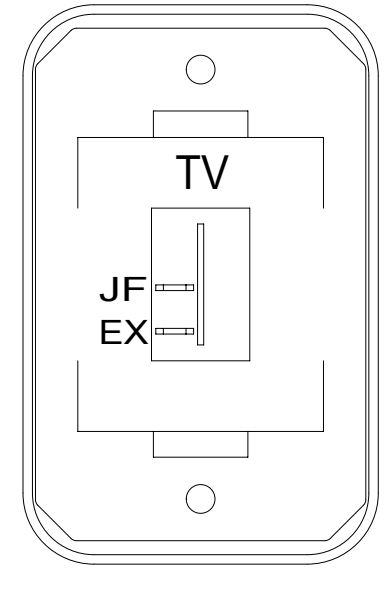

PLATE-SWITCH
144363-02-CHT
SWITCH
108357-06-000
ACTUATOR
108356-24-CHT
SCREW
G11-08-08U (2)



LABEL-WARNING,
SLIDEOUT
116549-02-000

DETAIL CA



SWITCH-ROCKER
135740-01-CHT
SWITCH-BASE
135741-01-CHT
SWITCH-BEZEL
135742-45-CHT
SCREW
G11-08-08U (2)

DETAIL CH 644

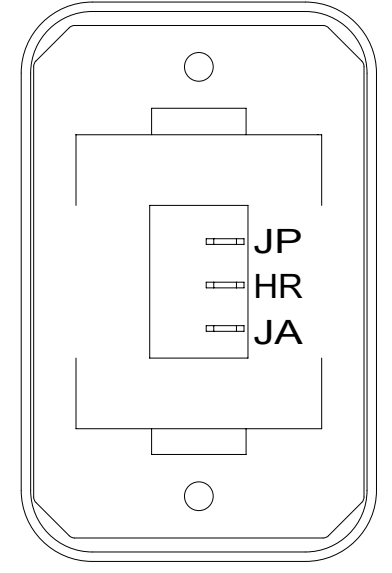

SWITCH-ROCKER
135740-06-CHT
SWITCH-BASE
135741-01-CHT
SWITCH-BEZEL
135742-01-CHT
LABEL-SWITCH
134563-01-CHT
SCREW
G11-08-08U (2)

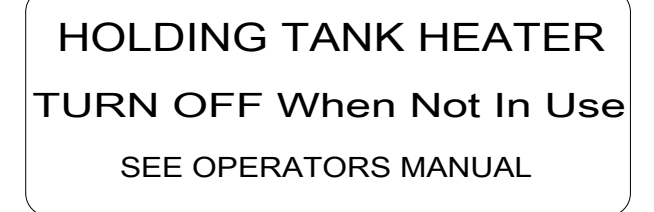

DETAIL CE 23T 23R

644 52N
52F

SWITCH-ROCKER
108357-06-000
ACTUATOR-SWITCH
108356-12-CHT
SWITCH-BLANK
096241-03-000

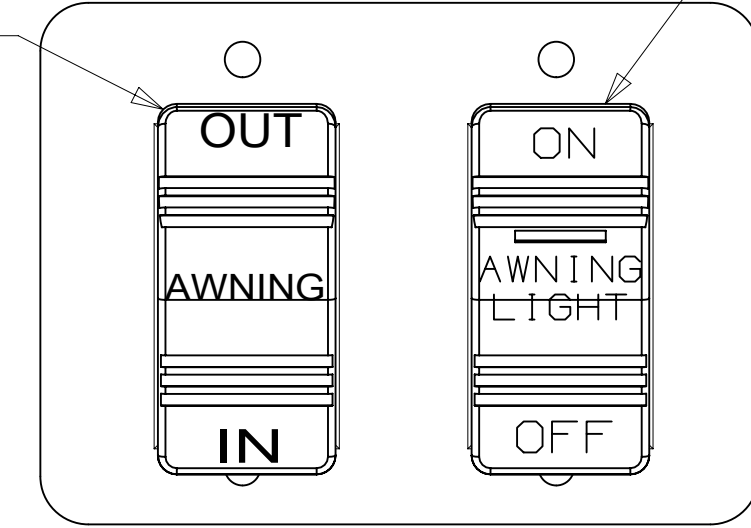

SWITCH-ROCKER
108357-14-000
ACTUATOR-SWITCH
108356-28-CHT
SWITCH-BLANK
096241-03-000

52N 644
52F

PLATE-SWITCH
98351-22-CHT
SCREW
G11-06-10U (4)

DETAIL CD

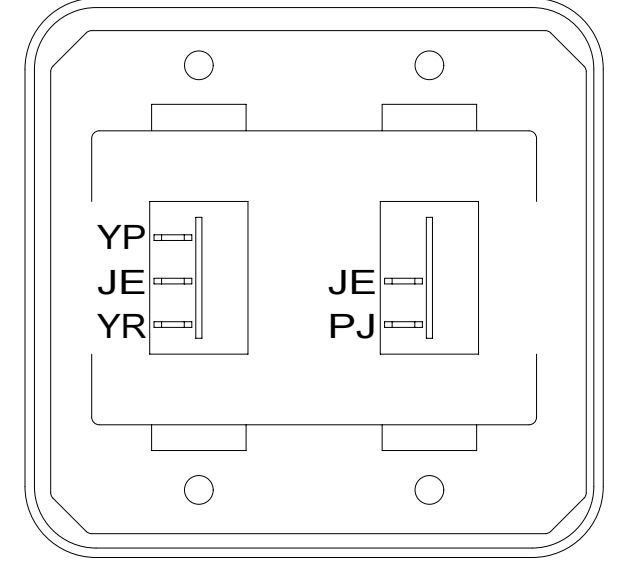

SWITCH-ROCKER
135740-01-CHT
135740-02-CHT
SWITCH-BASE
135741-02-CHT
SWITCH-BEZEL
135742-02-CHT
SCREW
G11-08-08U (4)

DETAIL CB

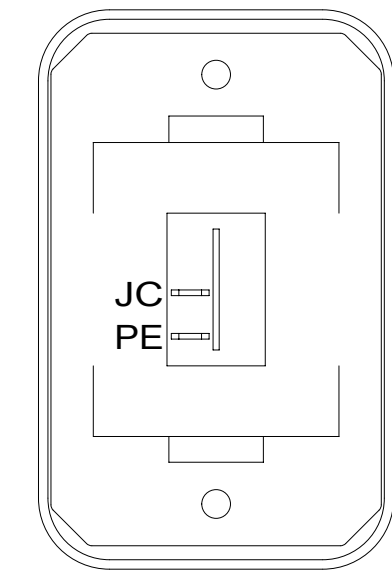

SWITCH-ROCKER
135740-01-CHT
SWITCH-BASE
135741-01-CHT
SWITCH-BEZEL
135742-01-CHT
SCREW
G11-08-08U (2)

DETAIL CC

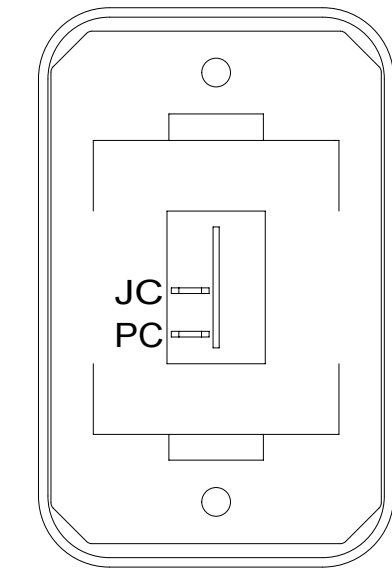

SWITCH-ROCKER
135740-01-CHT
SWITCH-BASE
135741-01-CHT
SWITCH-BEZEL
135742-01-CHT
SCREW
G11-08-08U (2)

DETAIL CK

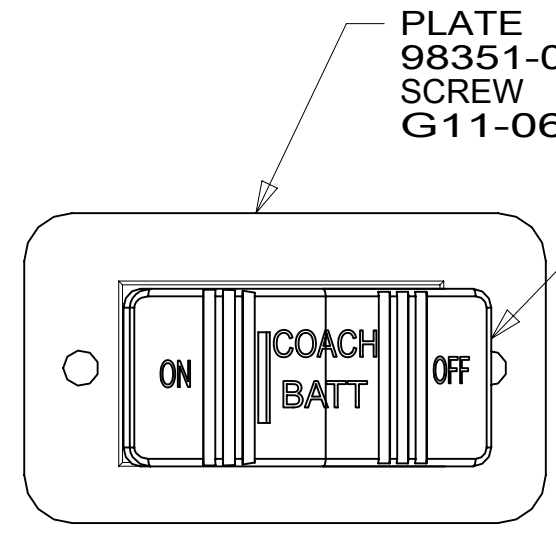
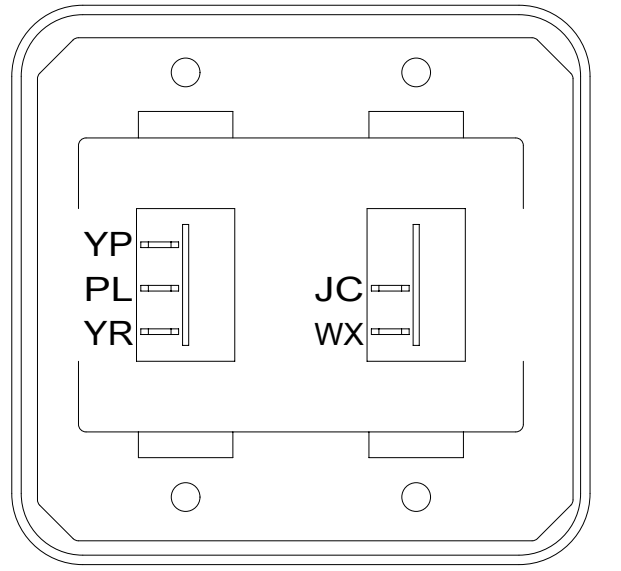

PLATE
98351-07-CHT
SCREW
G11-06-10U (4)

SWITCH-BATTERY
108357-18-000
ACTUATOR
108356-19-CHT
CIRCUITS LH,LJ,
LG,JP,JA
WIRE ASM-THERMISTOR
186796-01-000

DETAIL CG



SWITCH-ROCKER
135740-01-CHT
135740-02-CHT
SWITCH-BASE
135741-02-CHT
SWITCH-BEZEL
135742-02-CHT
SCREW
G11-08-08U (4)

DETAIL CJ

8 GRN
(GROUND)

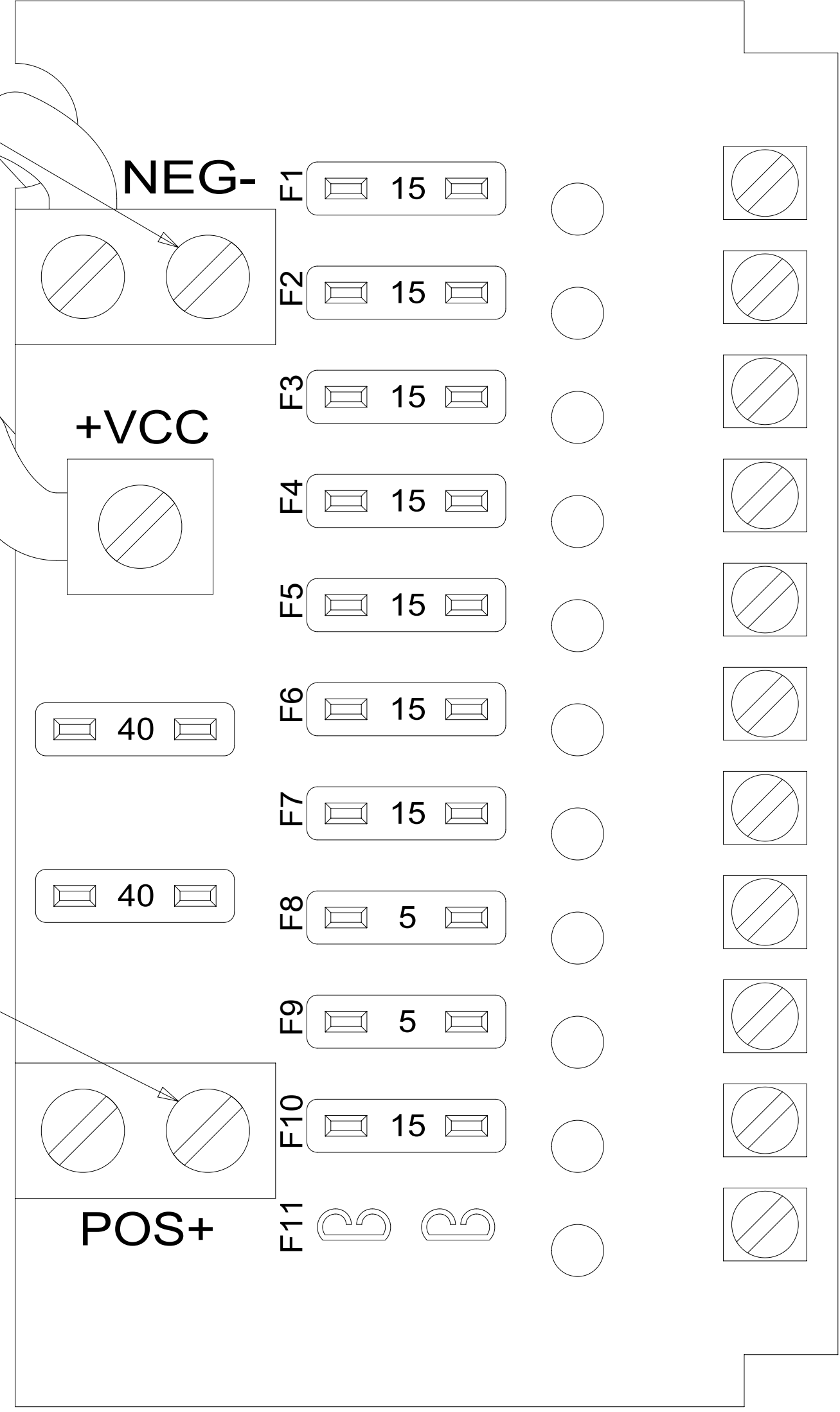

J
BLK
(BATTERY COMPT)

- JC 14 YEL (LAMPS)
- JD 14 YEL (LAMPS)
- JE 14 YEL (LAMPS)
- NM 12 YEL 23T (HEATED TANKS)
- JA 12 YEL (MONITOR PANEL & PUMP) (ISOLATED CIRCUIT)
- JB 14 YEL (FURNACE)
- FFD 12 YEL (AWNING)
- WB 16 YEL (LP LEAK DETECTOR)
- ET 16 YEL (REFRIG)
- JF 14 YEL (TV/RADIO POWER) 644

DETAIL CF 1

1 FOR REFERENCE ONLY. SEE LOAD CENTER/ATS ASM FOR ADDITIONAL INFORMATION.

NOTES:

FOR ELECTRICAL TORQUE SPECIFICATIONS SEE DWG NO. 128783-01-000

FOR ELECTRICAL CALLOUTS SEE DWG NO. 121339-01-000

- 52F AWNING-PATIO
- 52N AWNING - PATIO, ELECTRIC
- 644 GREAT ALASKAN RENTAL PACKAGE
- 23R DRAINAGE SYSTEM/HEAT-PREWIRE
- 23T DRAINAGE SYSTEM-HEATED
- 265 CODES/STANDARDS-CSA/CMVSS
- 1B1 CODES/STANDARDS USA

DESCRIPTION: WIRING INSTL-BODY, 12V	
SHEET: 3 OF 5	ITEM/PART NO: 000180019 / 30082201000
REV 1 20-Sep-2016	

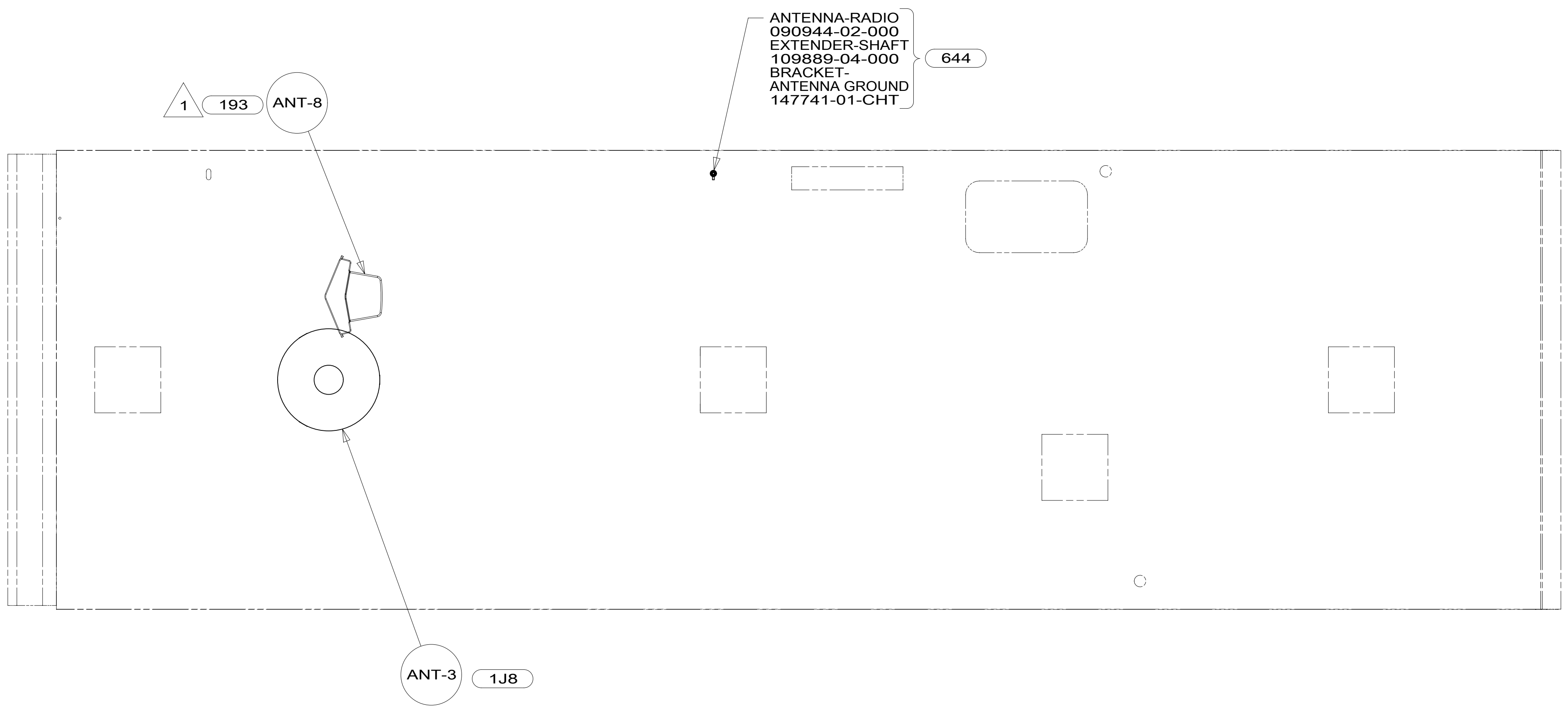
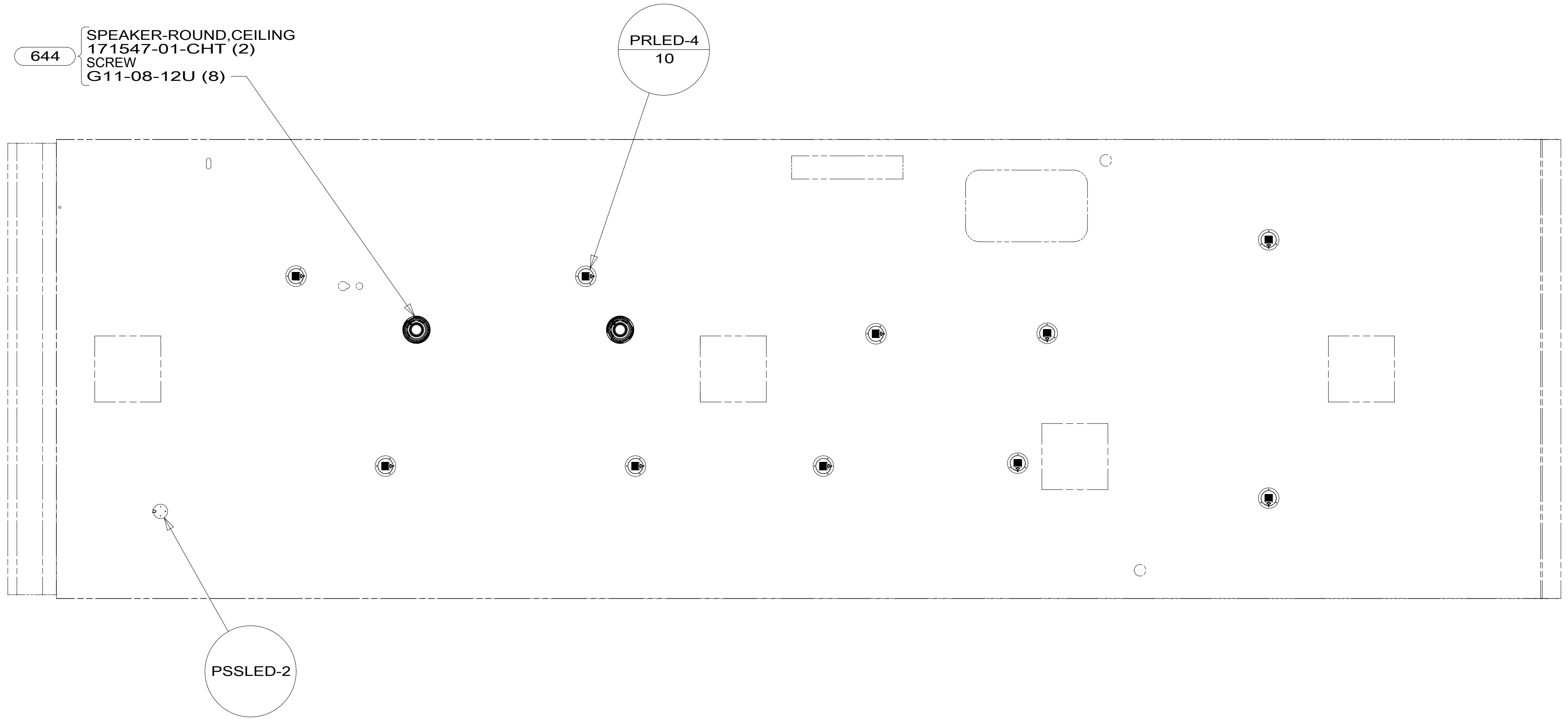

1 SEE ANTENNA INSTALLATION MANUAL FOR CORRECT INSTALLATION PROCEDURE.

NOTES:

FOR ELECTRICAL TORQUE SPECIFICATIONS SEE DWG NO. 128783-01-000

FOR ELECTRICAL CALLOUTS SEE DWG NO. 121339-01-000

- 644 GREAT ALASKAN RENTAL PACKAGE
- 1J8 TV ANTENNA-OMNI DIRECTIONAL
- 193 TV ANTENNA-AMPLIFIED SYSTEM
- 265 CODES/STANDARDS-CSA/CMVSS
- 1B1 CODES/STANDARDS USA

1B1	265
DESCRIPTION: WIRING INSTL-BODY, 12V	
SHEET: 4 OF 5	ITEM/PART NO: 000180019 / 30082201000
REV	

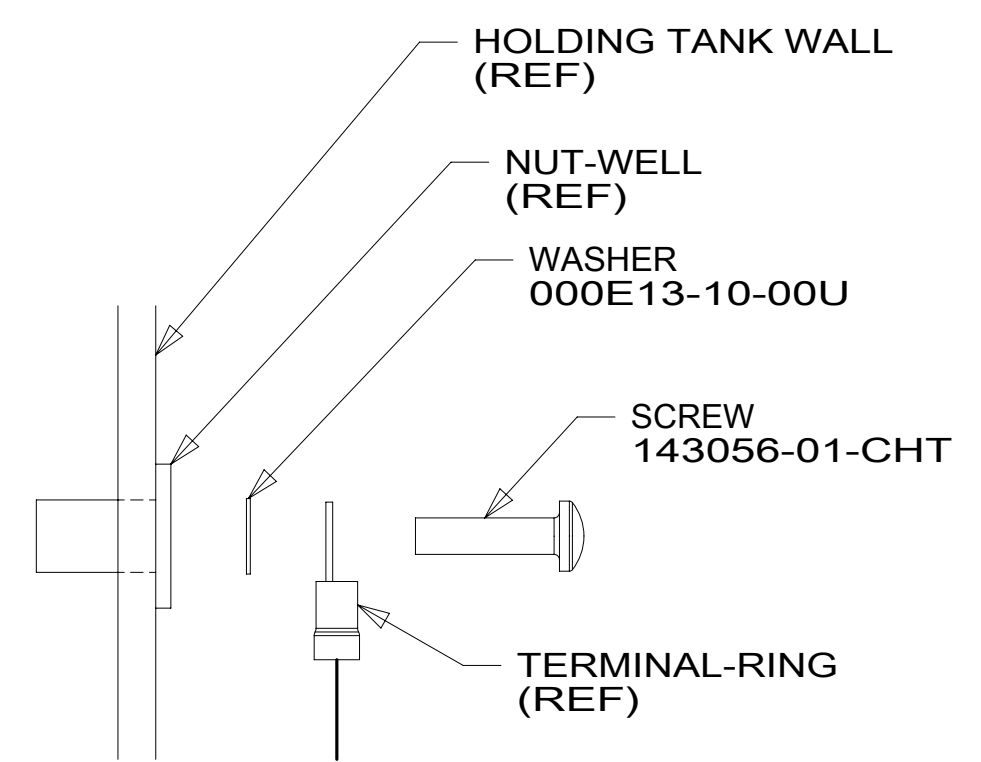

DETAIL EB 1

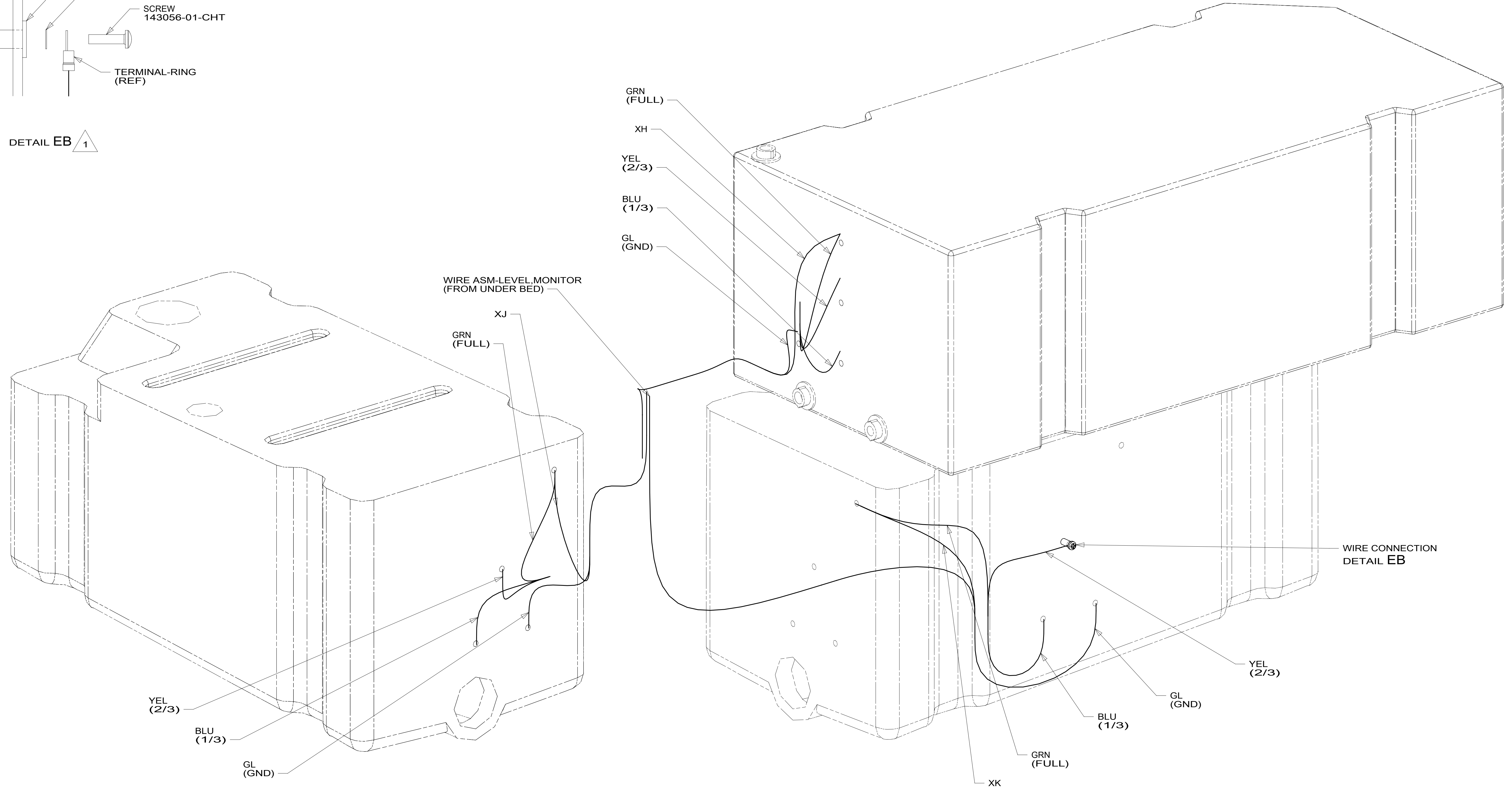

DETAIL EA

1 TYPICAL WIRE ATTACHMENT AT ALL LEVEL PROBES (4 EACH) FOR WATER, MAIN, AND AUX HOLDING TANKS.

NOTES:

FOR ELECTRICAL TORQUE SPECIFICATIONS SEE DWG NO. 128783-01-000

FOR ELECTRICAL CALLOUTS SEE DWG NO. 121339-01-000

- 265 CODES/STANDARDS-CSA/CMVSS
- 1B1 CODES/STANDARDS USA

DESCRIPTION:	
WIRING INSTL-BODY, 12V	
SHEET: 5 OF 5	ITEM/PART NO: 000180019 / 30082201000
REV	