

8 7 6 5 4 3 2 1

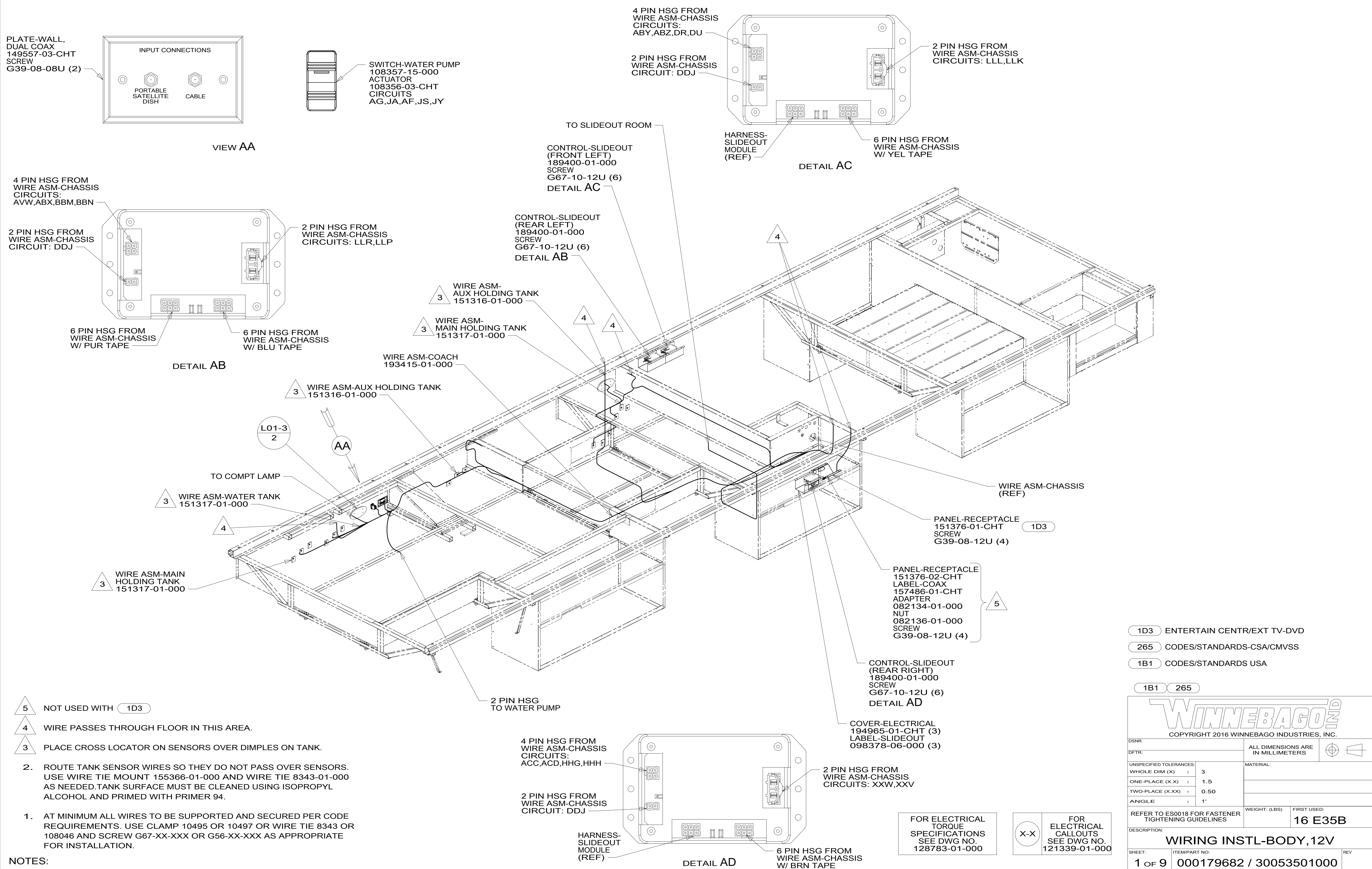

- 5 NOT USED WITH 1D3
- 4 WIRE PASSES THROUGH FLOOR IN THIS AREA.
- 3 PLACE CROSS LOCATOR ON SENSORS OVER DIMPLES ON TANK.
2. ROUTE TANK SENSOR WIRES SO THEY DO NOT PASS OVER SENSORS. USE WIRE TIE MOUNT 155366-01-000 AND WIRE TIE 8343-01-000 AS NEEDED. TANK SURFACE MUST BE CLEANED USING ISOPROPYL ALCOHOL AND PRIMED WITH PRIMER 94.
1. AT MINIMUM ALL WIRES TO BE SUPPORTED AND SECURED PER CODE REQUIREMENTS. USE CLAMP 10495 OR 10497 OR WIRE TIE 8343 OR 108046 AND SCREW G67-XX-XXX OR G56-XX-XXX AS APPROPRIATE FOR INSTALLATION.

NOTES:

- 1D3 ENTERTAIN CENTR/EXT TV-DVD
- 265 CODES/STANDARDS-CSA/CMVSS
- 1B1 CODES/STANDARDS USA

1B1 265

WINNEBAGO
COPYRIGHT 2016 WINNEBAGO INDUSTRIES, INC.

DSNR:	ALL DIMENSIONS ARE IN MILLIMETERS	
DFFR:		
UNSPECIFIED TOLERANCES:		MATERIAL:
WHOLE DIM (X)	± 3	
ONE-PLACE (X.X)	± 1.5	
TWO-PLACE (X.XX)	± 0.50	
ANGLE	± 1°	
REFER TO ES0018 FOR FASTENER TIGHTENING GUIDELINES	WEIGHT: (LBS)	FIRST USED:
		16 E35B
DESCRIPTION: WIRING INSTL-BODY, 12V		
SHEET: 1 OF 9	ITEM/PART NO: 000179682 / 30053501000	REV:

FOR ELECTRICAL TORQUE SPECIFICATIONS SEE DWG NO. 128783-01-000

FOR ELECTRICAL CALLOUTS SEE DWG NO. 121339-01-000

8 7 6 5 4 3 2 1

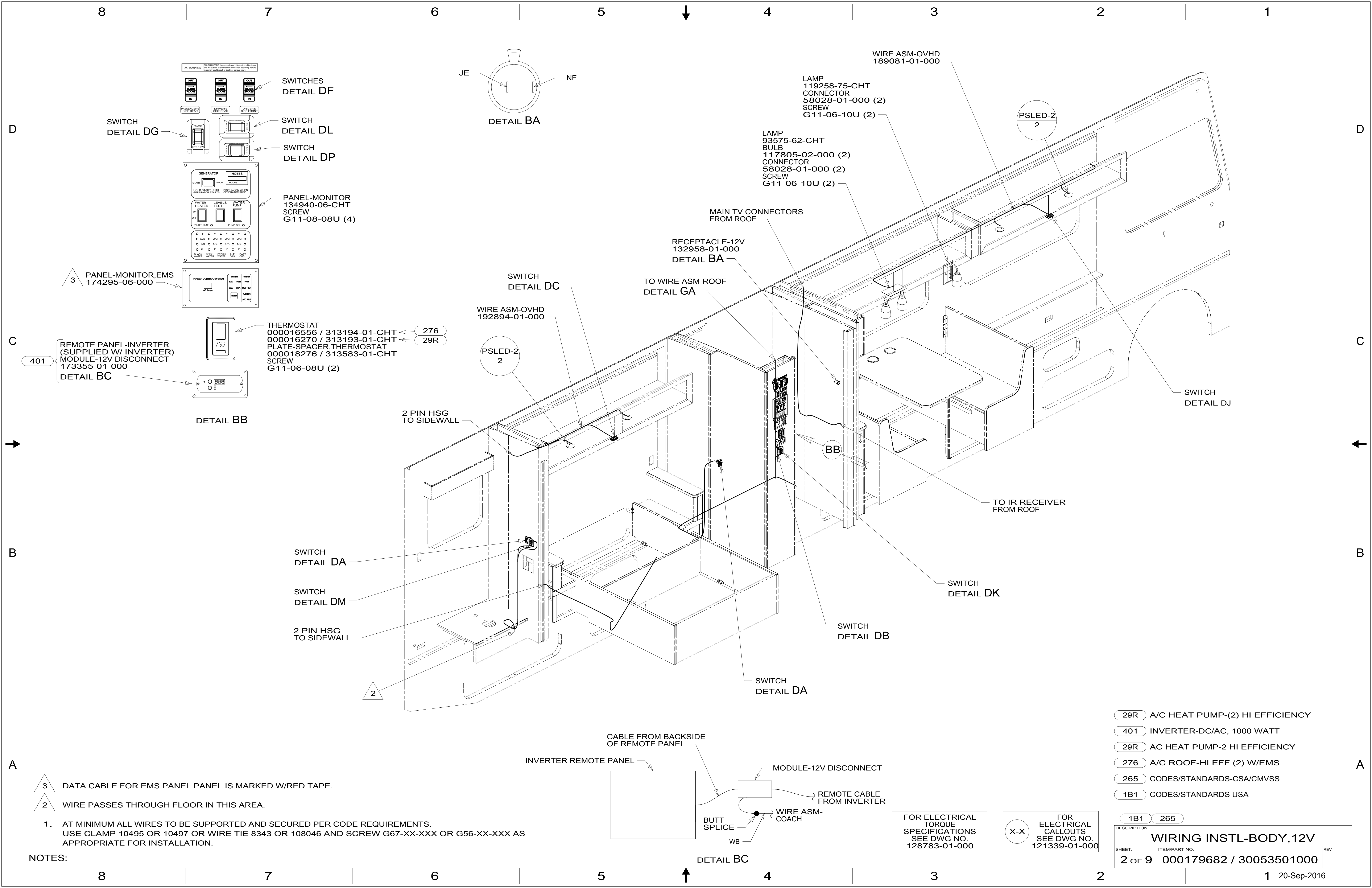

3 PANEL-MONITOR,EMS
174295-06-000

401 REMOTE PANEL-INVERTER
(SUPPLIED W/ INVERTER)
MODULE-12V DISCONNECT
173355-01-000
DETAIL BC

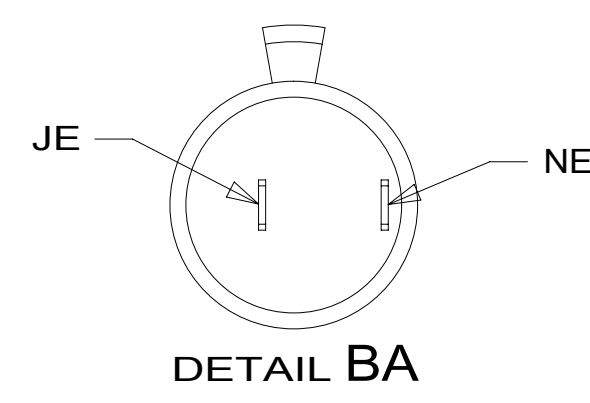
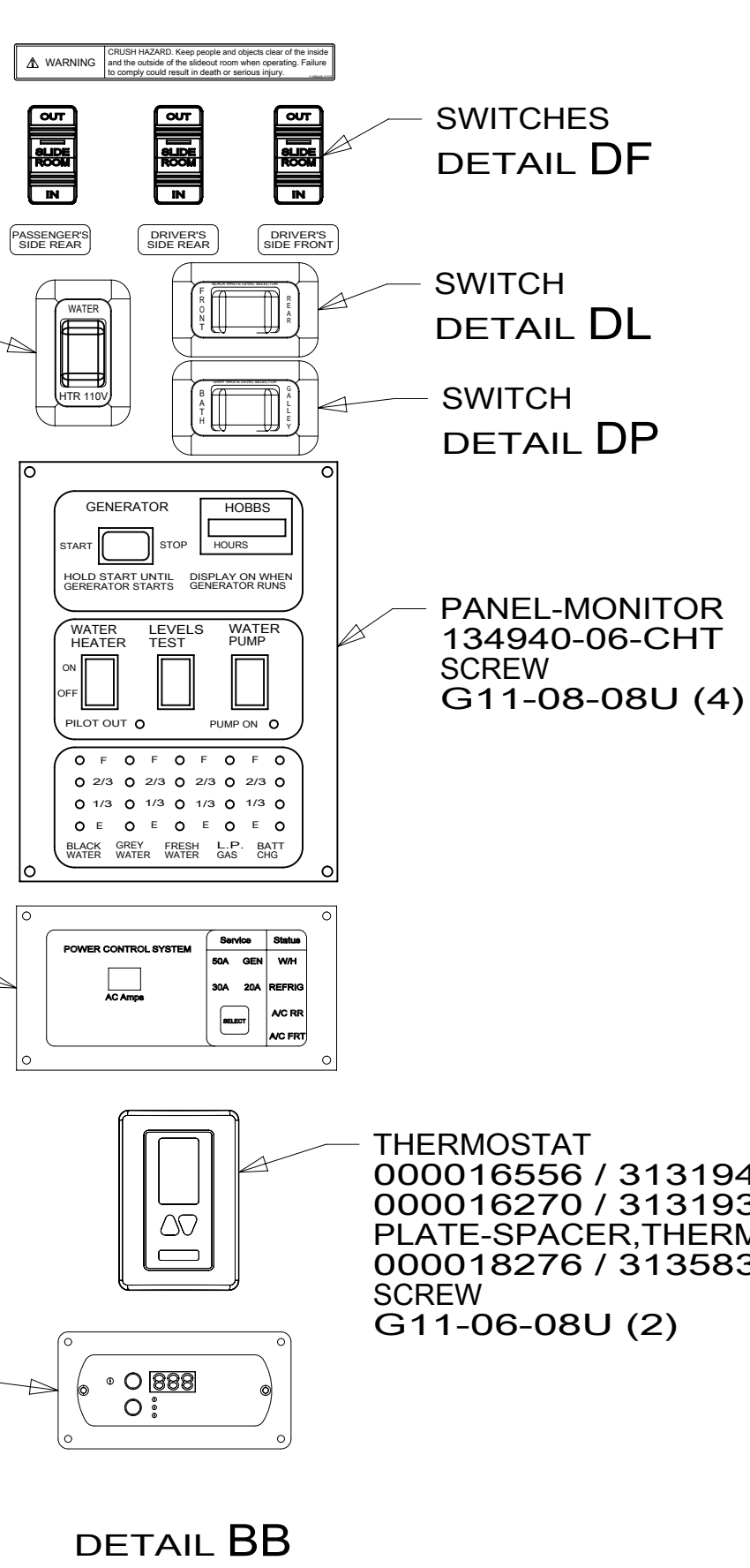

WIRE ASM-OVHD
189081-01-000

LAMP
119258-75-CHT
CONNECTOR
58028-01-000 (2)
SCREW
G11-06-10U (2)

LAMP
93575-62-CHT
BULB
117805-02-000 (2)
CONNECTOR
58028-01-000 (2)
SCREW
G11-06-10U (2)

RECEPTACLE-12V
132958-01-000
DETAIL BA

TO WIRE ASM-ROOF
DETAIL GA

SWITCH
DETAIL DC

WIRE ASM-OVHD
192894-01-000

PSLED-2
2

SWITCH
DETAIL DA

SWITCH
DETAIL DM

2 PIN HSG
TO SIDEWALL

SWITCH
DETAIL DB

SWITCH
DETAIL DK

SWITCH
DETAIL DA

TO IR RECEIVER
FROM ROOF

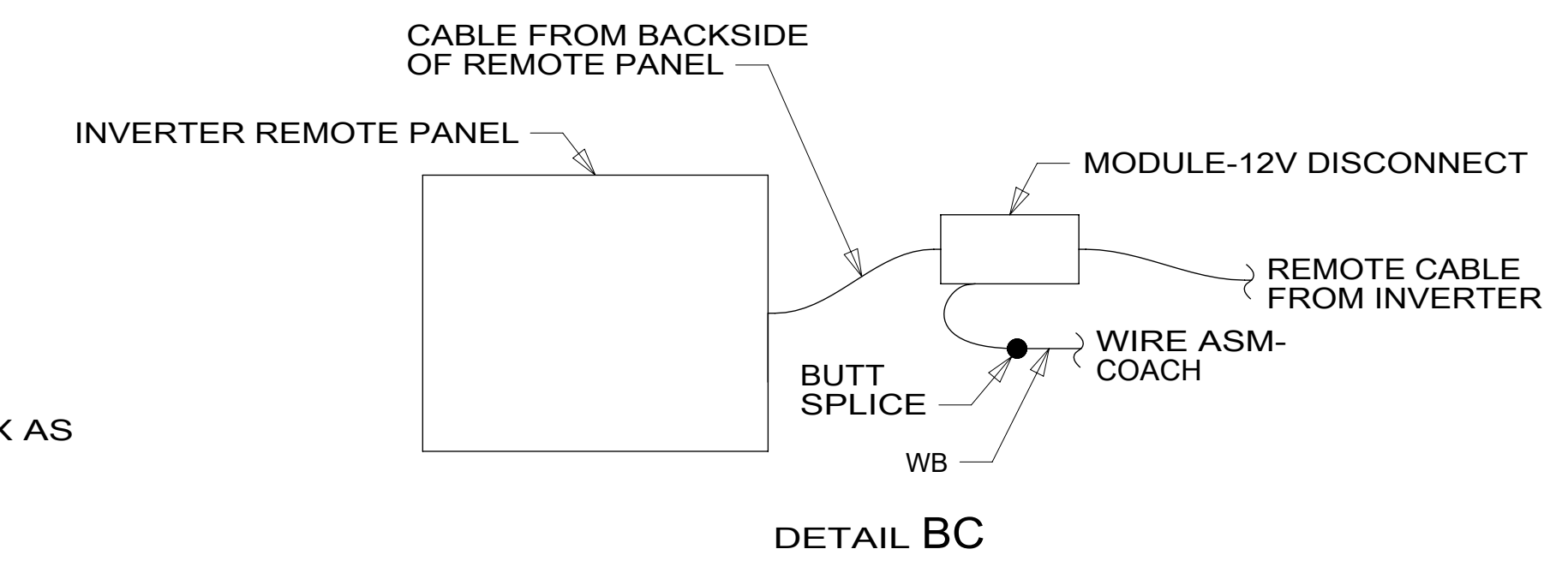

FOR ELECTRICAL
TORQUE
SPECIFICATIONS
SEE DWG NO.
128783-01-000

FOR ELECTRICAL
CALLOUTS
SEE DWG NO.
121339-01-000

- 29R A/C HEAT PUMP-(2) HI EFFICIENCY
- 401 INVERTER-DC/AC, 1000 WATT
- 29R AC HEAT PUMP-2 HI EFFICIENCY
- 276 A/C ROOF-HI EFF (2) W/EMS
- 265 CODES/STANDARDS-CSA/CMVSS
- 1B1 CODES/STANDARDS USA

NOTES:

3 DATA CABLE FOR EMS PANEL IS MARKED W/RED TAPE.

2 WIRE PASSES THROUGH FLOOR IN THIS AREA.

1. AT MINIMUM ALL WIRES TO BE SUPPORTED AND SECURED PER CODE REQUIREMENTS.
USE CLAMP 10495 OR 10497 OR WIRE TIE 8343 OR 108046 AND SCREW G67-XX-XXX OR G56-XX-XXX AS APPROPRIATE FOR INSTALLATION.

DESCRIPTION: WIRING INSTL-BODY, 12V	
SHEET: 2 OF 9	ITEM/PART NO: 000179682 / 30053501000
REV	

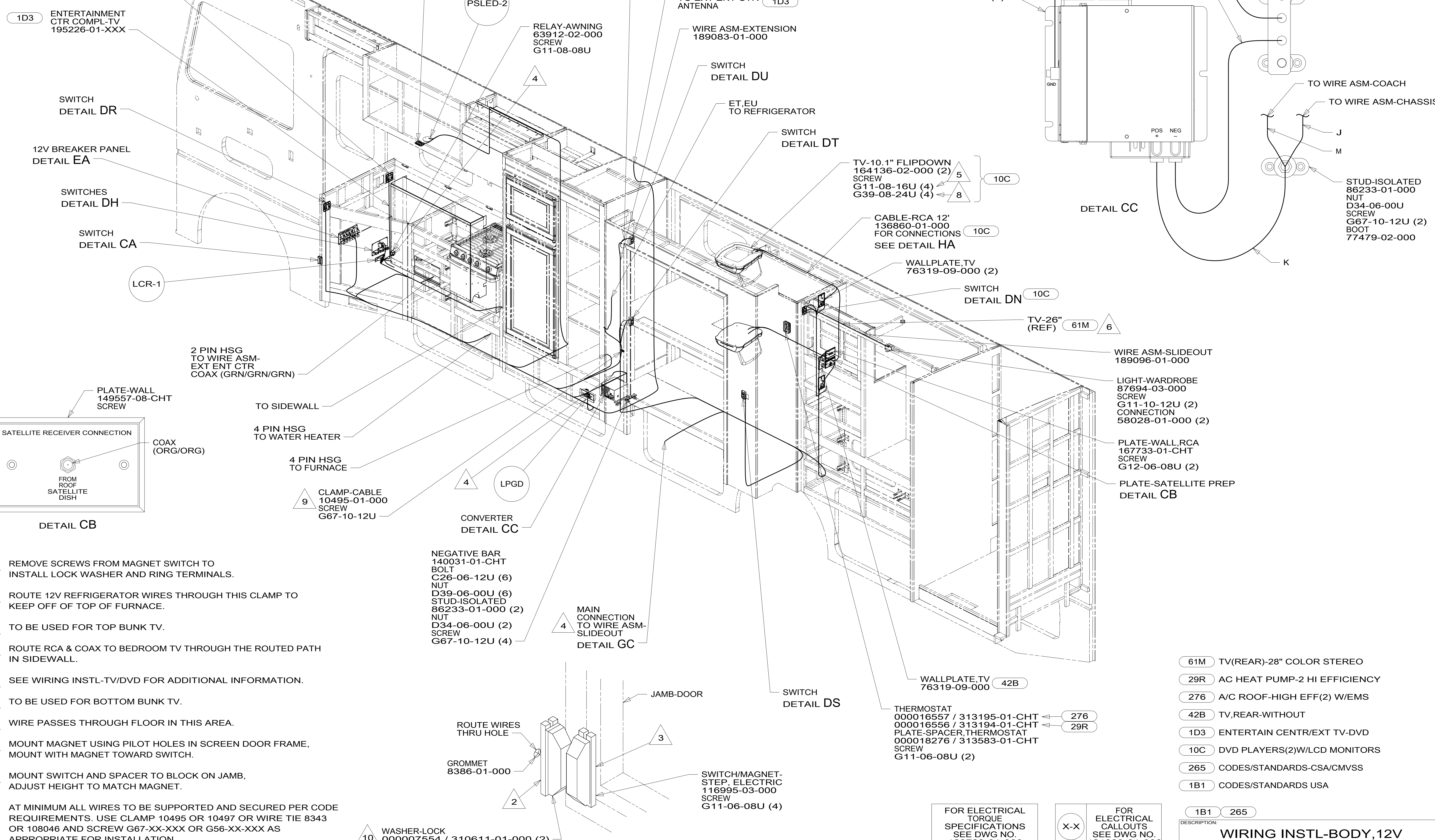
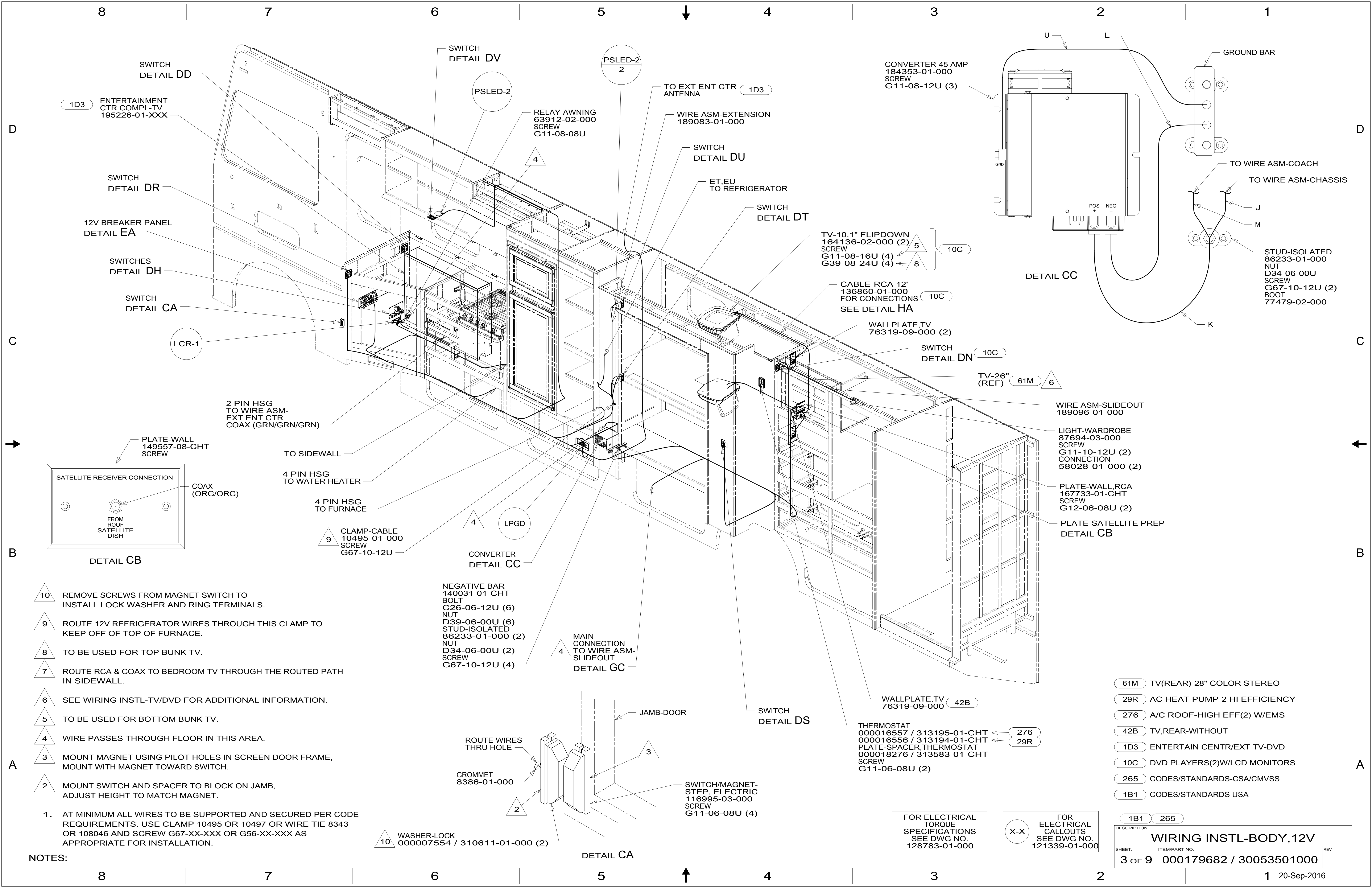

- NOTES:
- 1. AT MINIMUM ALL WIRES TO BE SUPPORTED AND SECURED PER CODE REQUIREMENTS. USE CLAMP 10495 OR 10497 OR WIRE TIE 8343 OR 108046 AND SCREW G67-XX-XXX OR G56-XX-XXX AS APPROPRIATE FOR INSTALLATION.
 - 2. MOUNT SWITCH AND SPACER TO BLOCK ON JAMB, ADJUST HEIGHT TO MATCH MAGNET.
 - 3. MOUNT MAGNET USING PILOT HOLES IN SCREEN DOOR FRAME, MOUNT WITH MAGNET TOWARD SWITCH.
 - 4. WIRE PASSES THROUGH FLOOR IN THIS AREA.
 - 5. TO BE USED FOR BOTTOM BUNK TV.
 - 6. SEE WIRING INSTL-TV/DVD FOR ADDITIONAL INFORMATION.
 - 7. ROUTE RCA & COAX TO BEDROOM TV THROUGH THE ROUTED PATH IN SIDEWALL.
 - 8. TO BE USED FOR TOP BUNK TV.
 - 9. ROUTE 12V REFRIGERATOR WIRES THROUGH THIS CLAMP TO KEEP OFF OF TOP OF FURNACE.
 - 10. REMOVE SCREWS FROM MAGNET SWITCH TO INSTALL LOCK WASHER AND RING TERMINALS.

61M	TV(REAR)-28" COLOR STEREO
29R	AC HEAT PUMP-2 HI EFFICIENCY
276	A/C ROOF-HIGH EFF(2) W/EMS
42B	TV,REAR-WITHOUT
1D3	ENTERTAIN CENTR/EXT TV-DVD
10C	DVD PLAYERS(2)W/LCD MONITORS
265	CODES/STANDARDS-CSA/CMVSS
1B1	CODES/STANDARDS USA

DESCRIPTION:
WIRING INSTL-BODY, 12V

SHEET: 3 OF 9 ITEM/PART NO.: 000179682 / 30053501000 REV

FOR ELECTRICAL TORQUE SPECIFICATIONS SEE DWG NO. 128783-01-000

FOR ELECTRICAL CALLOUTS SEE DWG NO. 121339-01-000

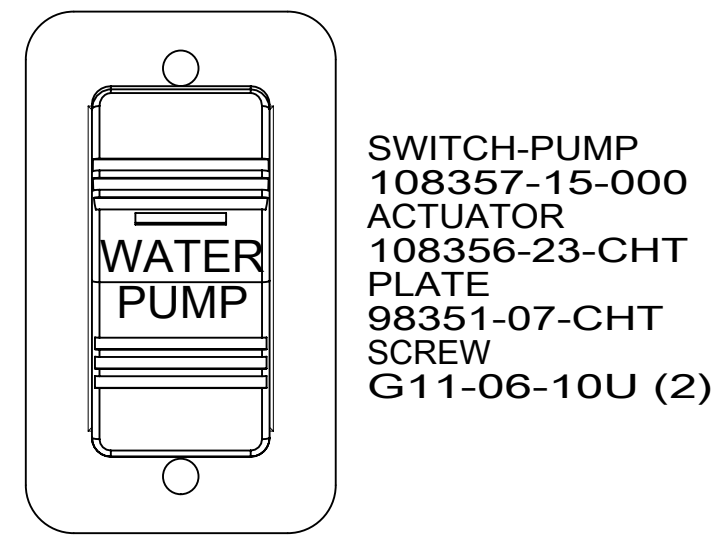

SWITCH-PUMP
108357-15-000
ACTUATOR
108356-23-CHT
PLATE
98351-07-CHT
SCREW
G11-06-10U (2)

DETAIL DA
(2 PLACES)

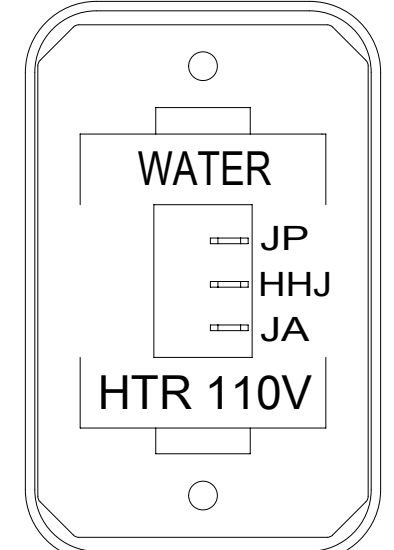

SWITCH-ROCKER
135740-06-CHT
SWITCH-BASE
135741-01-CHT
SWITCH-BEZEL
135742-35-CHT
SCREW
G11-08-08U (2)

DETAIL DG 53D

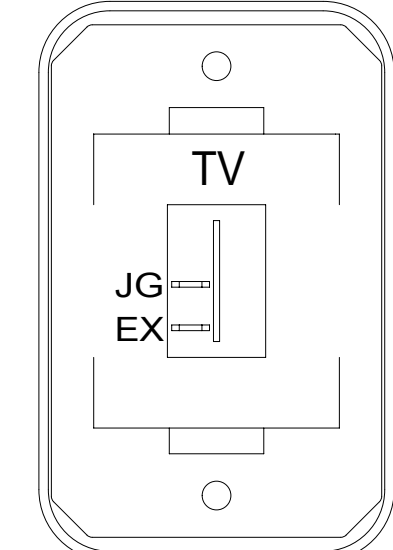

SWITCH-ROCKER
135740-01-CHT
SWITCH-BASE
135741-01-CHT
SWITCH-BEZEL
135742-45-CHT
SCREW
G11-08-08U (2)

DETAIL DN 10C

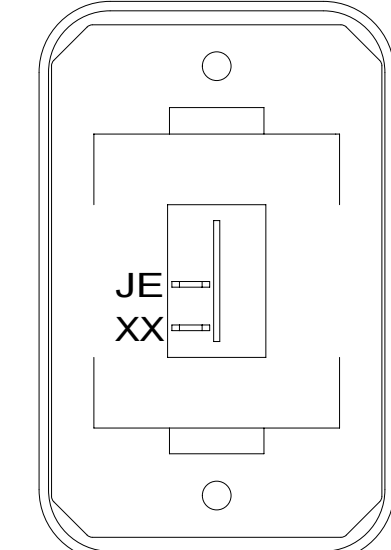

SWITCH-ROCKER
135740-01-CHT
SWITCH-BASE
135741-01-CHT
SWITCH-BEZEL
135742-01-CHT
SCREW
G11-08-08U (2)

DETAIL DJ

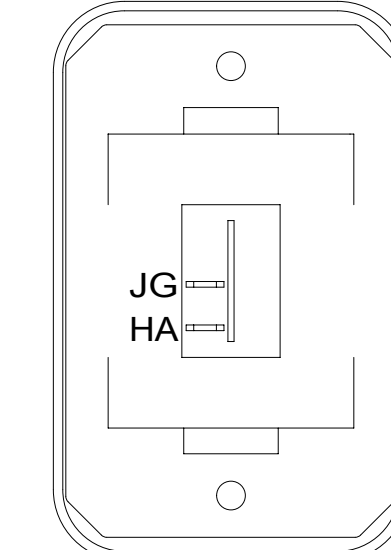

SWITCH-ROCKER
135740-01-CHT
SWITCH-BASE
135741-01-CHT
SWITCH-BEZEL
135742-01-CHT
SCREW
G11-08-08U (2)

DETAIL DT

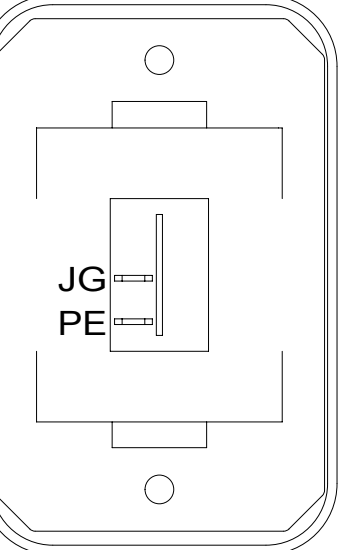

SWITCH-ROCKER
135740-01-CHT
SWITCH-BASE
135741-01-CHT
SWITCH-BEZEL
135742-01-CHT
SCREW
G11-08-08U (2)

DETAIL DB

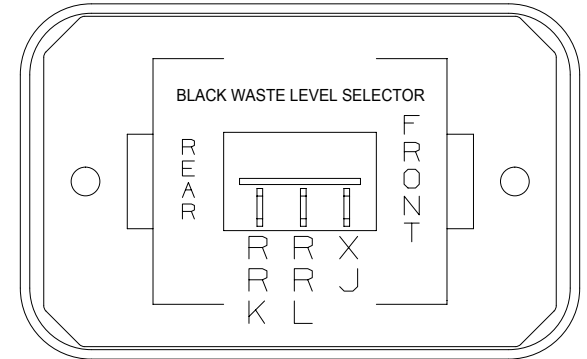

SWITCH-ROCKER
135740-02-CHT
SWITCH-BASE
135741-01-CHT
SWITCH-BEZEL
135742-61-CHT
SCREW
G11-08-08U (2)

DETAIL DL

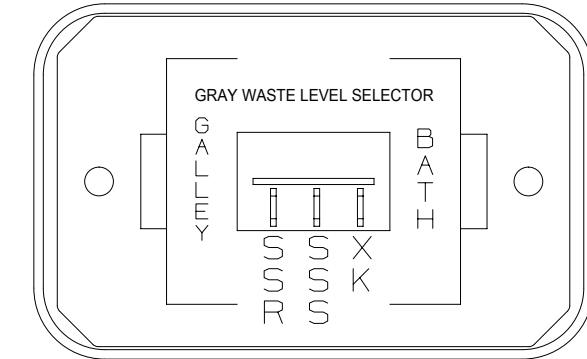

SWITCH-ROCKER
135740-02-CHT
SWITCH-BASE
135741-01-CHT
SWITCH-BEZEL
135742-52-CHT
SCREW
G11-08-08U (2)

DETAIL DP

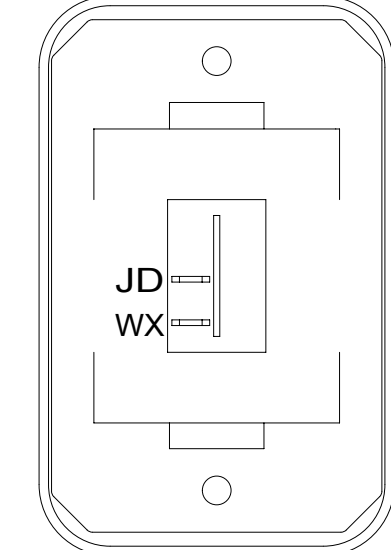

SWITCH-ROCKER
135740-01-CHT
SWITCH-BASE
135741-01-CHT
SWITCH-BEZEL
135742-01-CHT
SCREW
G11-08-08U (2)

DETAIL DK

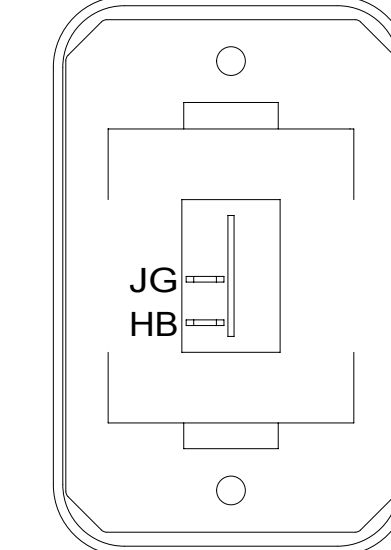

SWITCH-ROCKER
135740-01-CHT
SWITCH-BASE
135741-01-CHT
SWITCH-BEZEL
135742-01-CHT
SCREW
G11-08-08U (2)

DETAIL DU

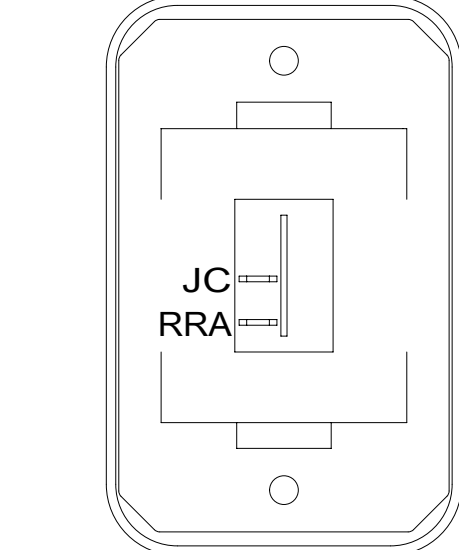

SWITCH-ROCKER
135740-01-CHT
SWITCH-BASE
135741-01-CHT
SWITCH-BEZEL
135742-01-CHT
SCREW
G11-08-08U (2)

DETAIL DC

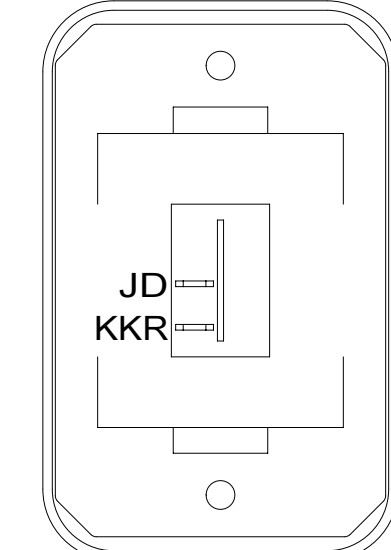

SWITCH-ROCKER
135740-01-CHT
SWITCH-BASE
135741-01-CHT
SWITCH-BEZEL
135742-01-CHT
SCREW
G11-08-08U (2)

DETAIL DM

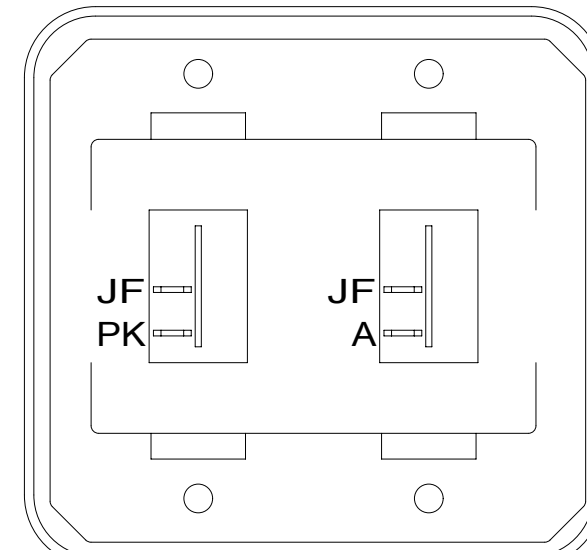

SWITCH-ROCKER
135740-01-CHT (2)
SWITCH-BASE
135741-02-CHT
SWITCH-BEZEL
135742-02-CHT
SCREW
G11-08-08U (4)

DETAIL DR

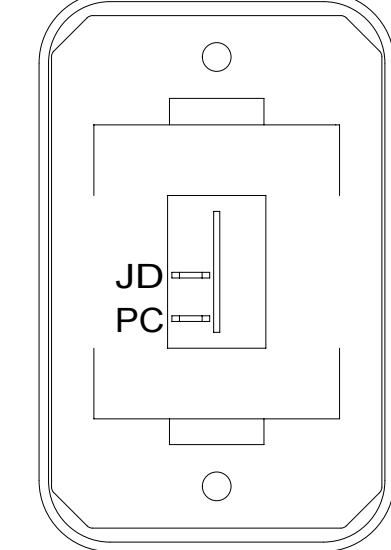

SWITCH-ROCKER
135740-01-CHT
SWITCH-BASE
135741-01-CHT
SWITCH-BEZEL
135742-01-CHT
SCREW
G11-08-08U (2)

DETAIL DS

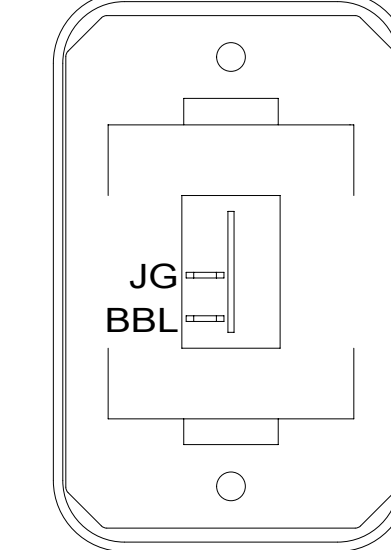

SWITCH-ROCKER
135740-01-CHT
SWITCH-BASE
135741-01-CHT
SWITCH-BEZEL
135742-01-CHT
SCREW
G11-08-08U (2)

DETAIL DV

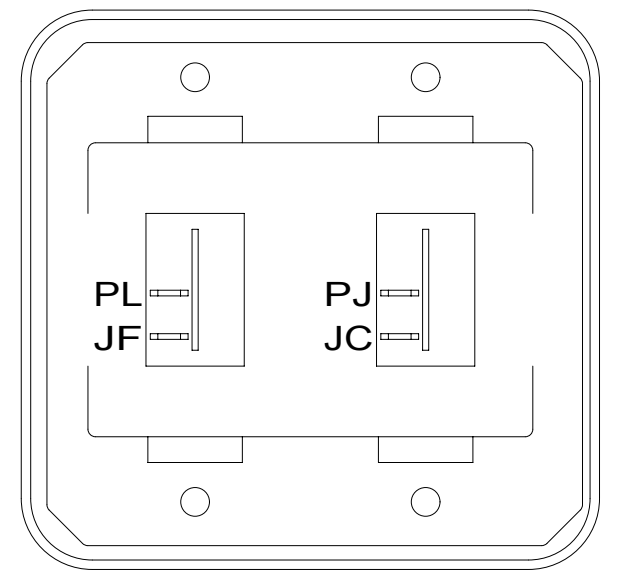

SWITCH-ROCKER
135740-01-CHT (2)
SWITCH-BASE
135741-02-CHT
SWITCH-BEZEL
135742-02-CHT
SCREW
G11-08-08U (4)

DETAIL DD

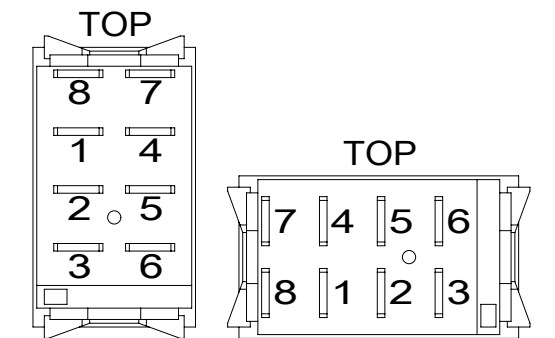

DETAIL DE

SWITCH
108357-18-000
ACTUATOR
108356-31-CHT
CIRCUITS
BBN,KE,BBM,ABW,ABX

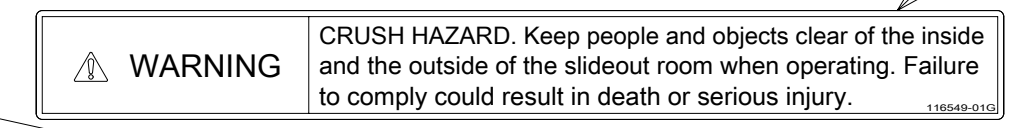

LABEL-WARNING,SLIDEOUT
116549-01-000

SWITCH
108357-18-000
ACTUATOR
108356-31-CHT
CIRCUITS
HHH,KE,HHG,ACC,ACD

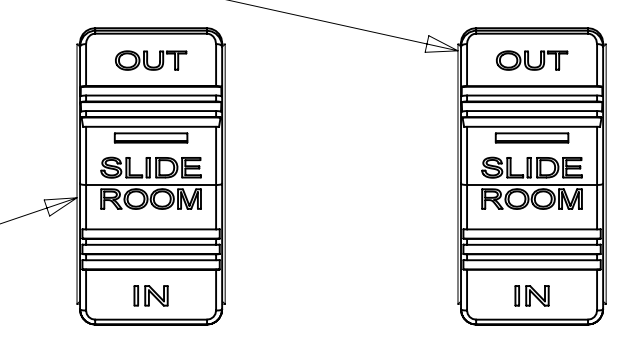

SWITCH
108357-18-000
ACTUATOR
108356-31-CHT
CIRCUITS
DU,KE,DR,ABY,ABZ

LABEL-SLIDEOUT
PASS,REAR
163992-03-CHT



LABEL-SLIDEOUT,
DRIVER,REAR
163992-02-CHT

LABEL-SLIDEOUT,
DRIVER,FRONT
163992-01-CHT

DETAIL DF

SWITCH-AWNING
108357-06-000
ACTUATOR-SWITCH
108356-12-CHT
CIRCUITS
FFD,FFR,FFE,
FFE,JJR,FFD

PLATE-SWITCH
158431-15-CHT
SCREW
G11-06-10U (6)

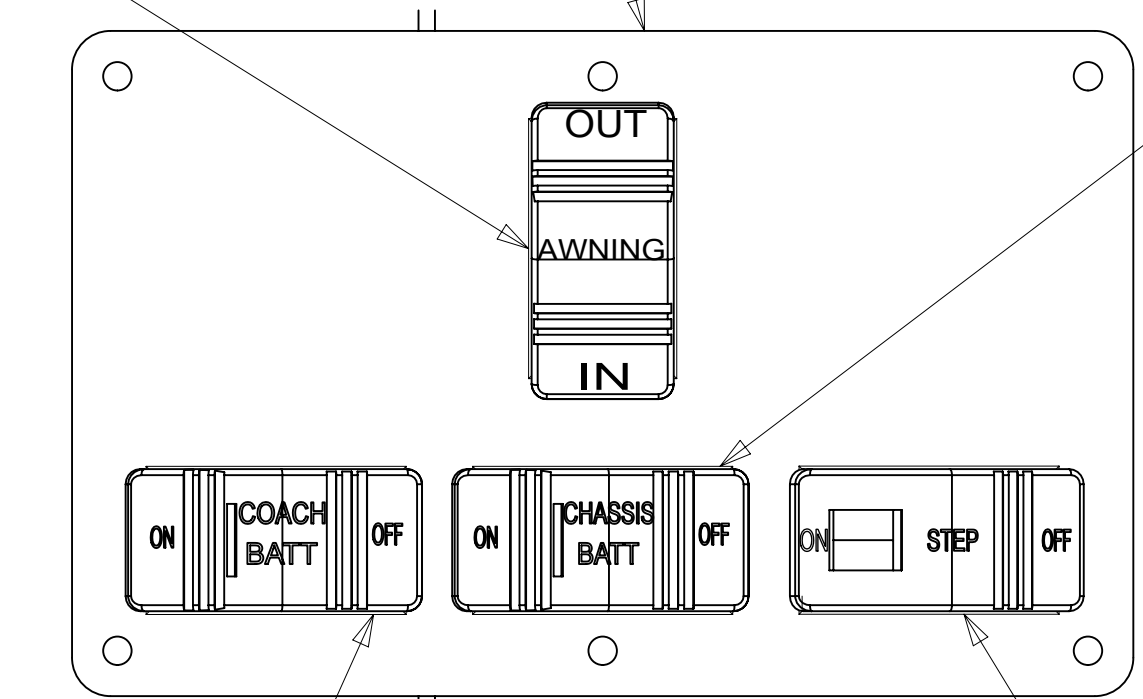

SWITCH-COACH BATT
108357-18-000
ACTUATOR-SWITCH
108356-19-CHT
CIRCUITS
KF,LG,LJ,LH,WC
WIRE ASM-THERM
186796-01-000

SWITCH-CHASSIS BATTERY
108357-18-000
ACTUATOR-SWITCH
108356-20-CHT
CIRCUITS
UUC,TTY,UUB
UUB,TTZ,MK
WIRE ASM-THERM
186796-01-000

SWITCH-STEP
108357-19-000
CIRCUITS
ER,ES

DETAIL DH 1

NOTES:
1 FOR SWITCH ORIENTATION SEE DETAIL DE

FOR ELECTRICAL
TORQUE
SPECIFICATIONS
SEE DWG NO.
128783-01-000

FOR ELECTRICAL
CALLOUTS
SEE DWG NO.
121339-01-000

- 45D LOFT BED - WITHOUT
- 45B LOFT BED
- 10C DVD PLAYERS(2)W/LCD MONITORS
- 53D WTR HTR-6GAL/ELE/LP/MOTOR/AID
- 265 CODES/STANDARDS-CSA/CMVSS
- 1B1 CODES/STANDARDS USA

DESCRIPTION:	1B1 265	
WIRING INSTL-BODY, 12V		
SHEET:	ITEM/PART NO:	REV
4 OF 9	000179682 / 30053501000	

8 7 6 5 4 3 2 1

D

D

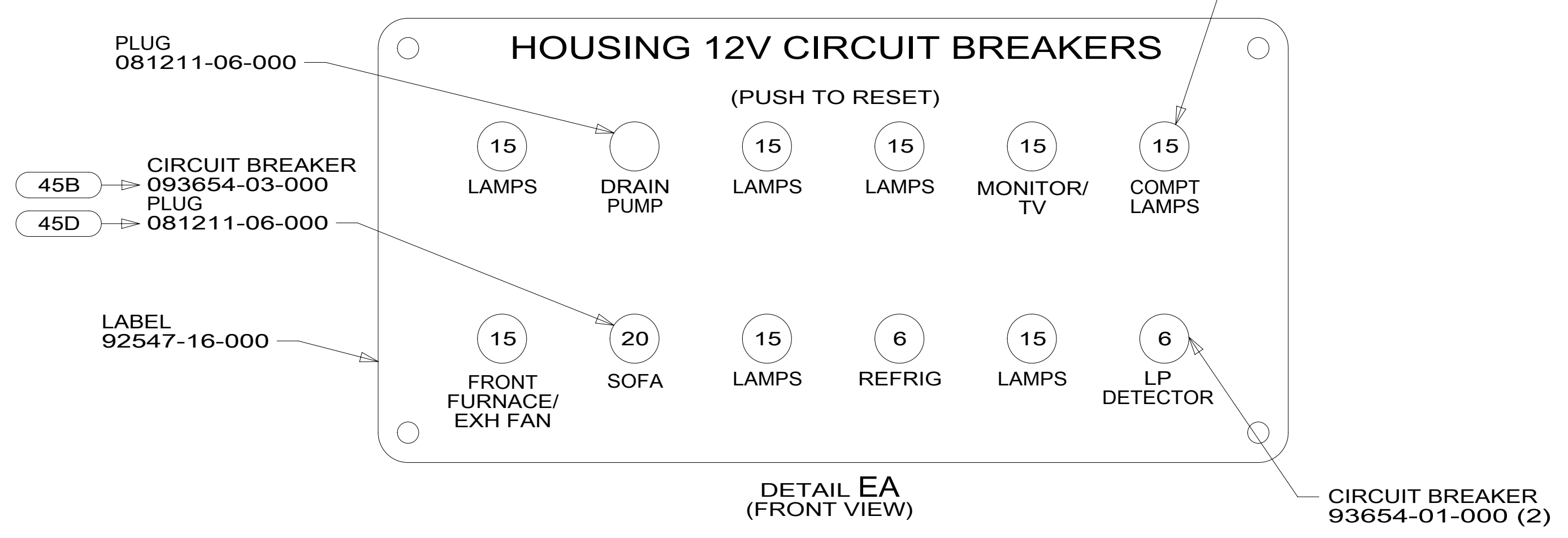
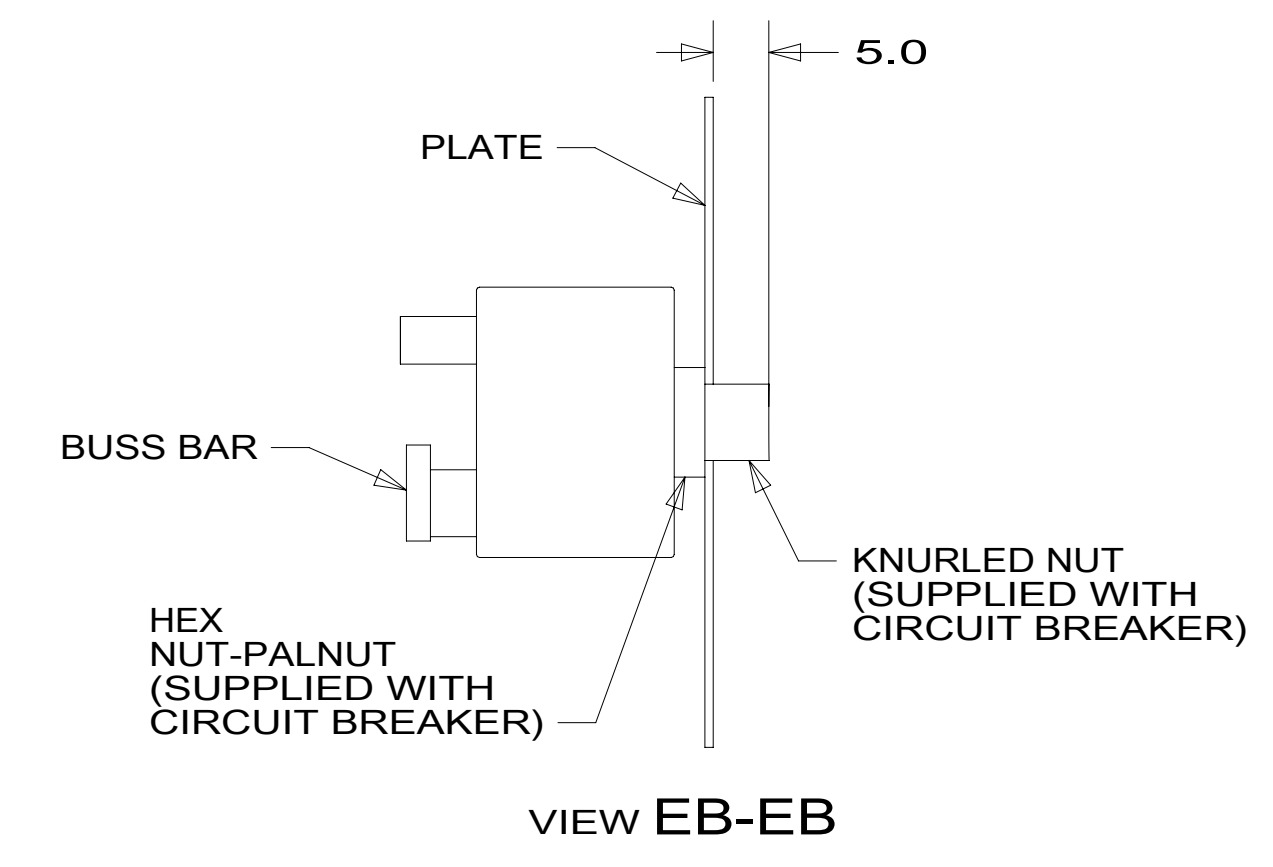
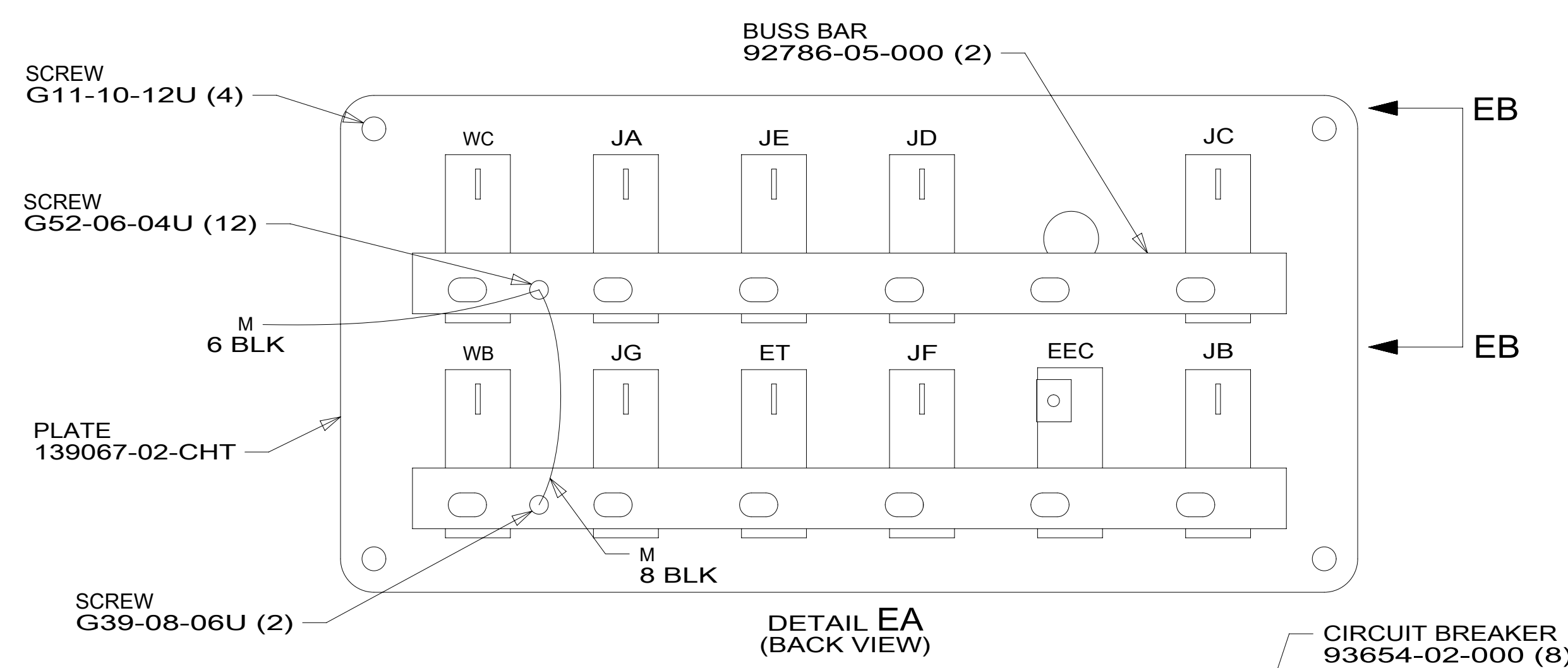

→

←

B

B

A

A

8 7 6 5 4 3 2 1

- 45D LOFT BED - WITHOUT
- 45B LOFT BED
- 265 CODES/STANDARDS-CSA/CMVSS
- 1B1 CODES/STANDARDS USA

FOR ELECTRICAL TORQUE SPECIFICATIONS SEE DWG NO. 128783-01-000

FOR ELECTRICAL CALLOUTS SEE DWG NO. 121339-01-000

DESCRIPTION: WIRING INSTL-BODY, 12V		
SHEET: 5 OF 9	ITEM/PART NO: 000179682 / 30053501000	REV

8 7 6 5 4 3 2 1

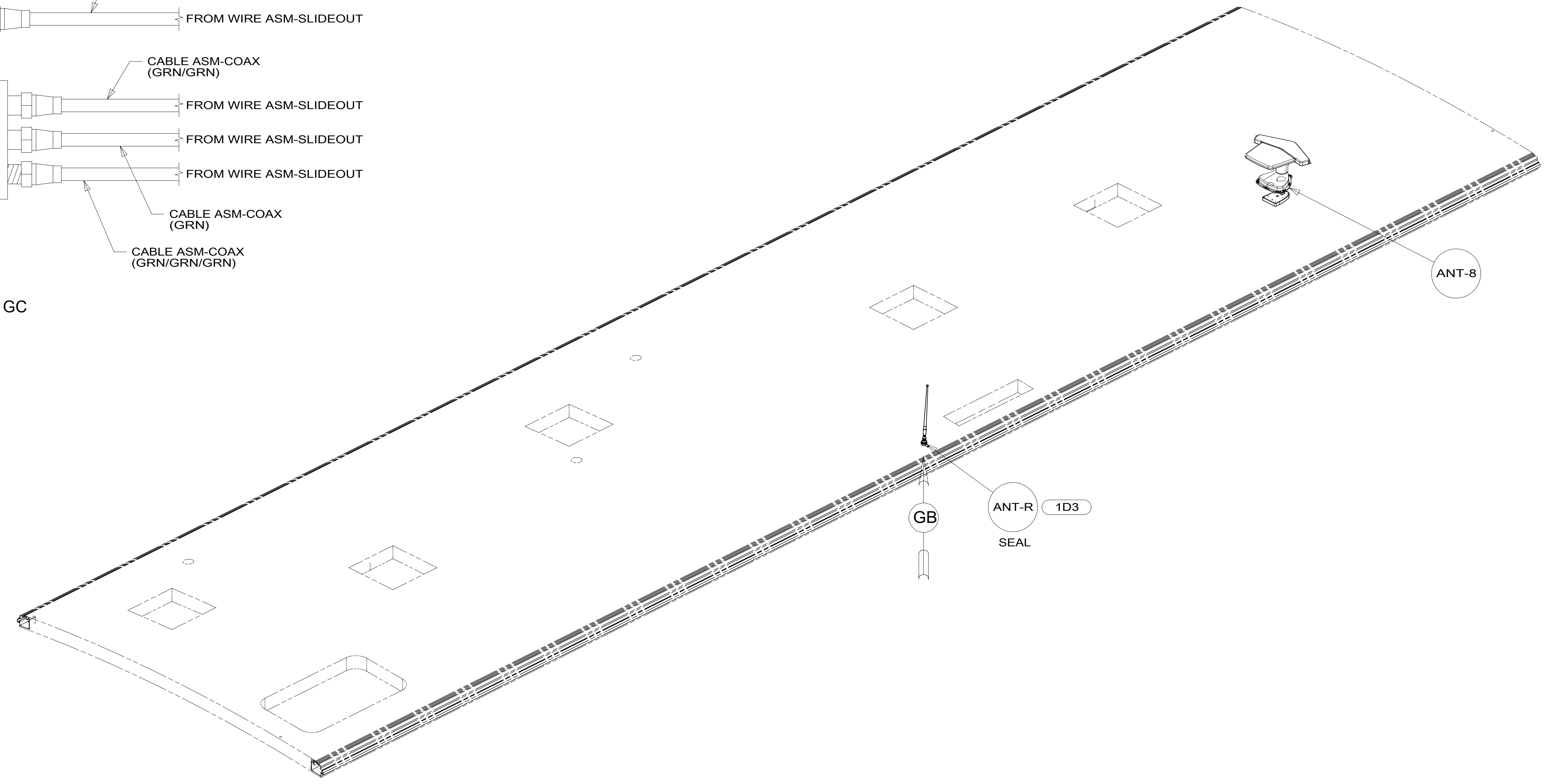
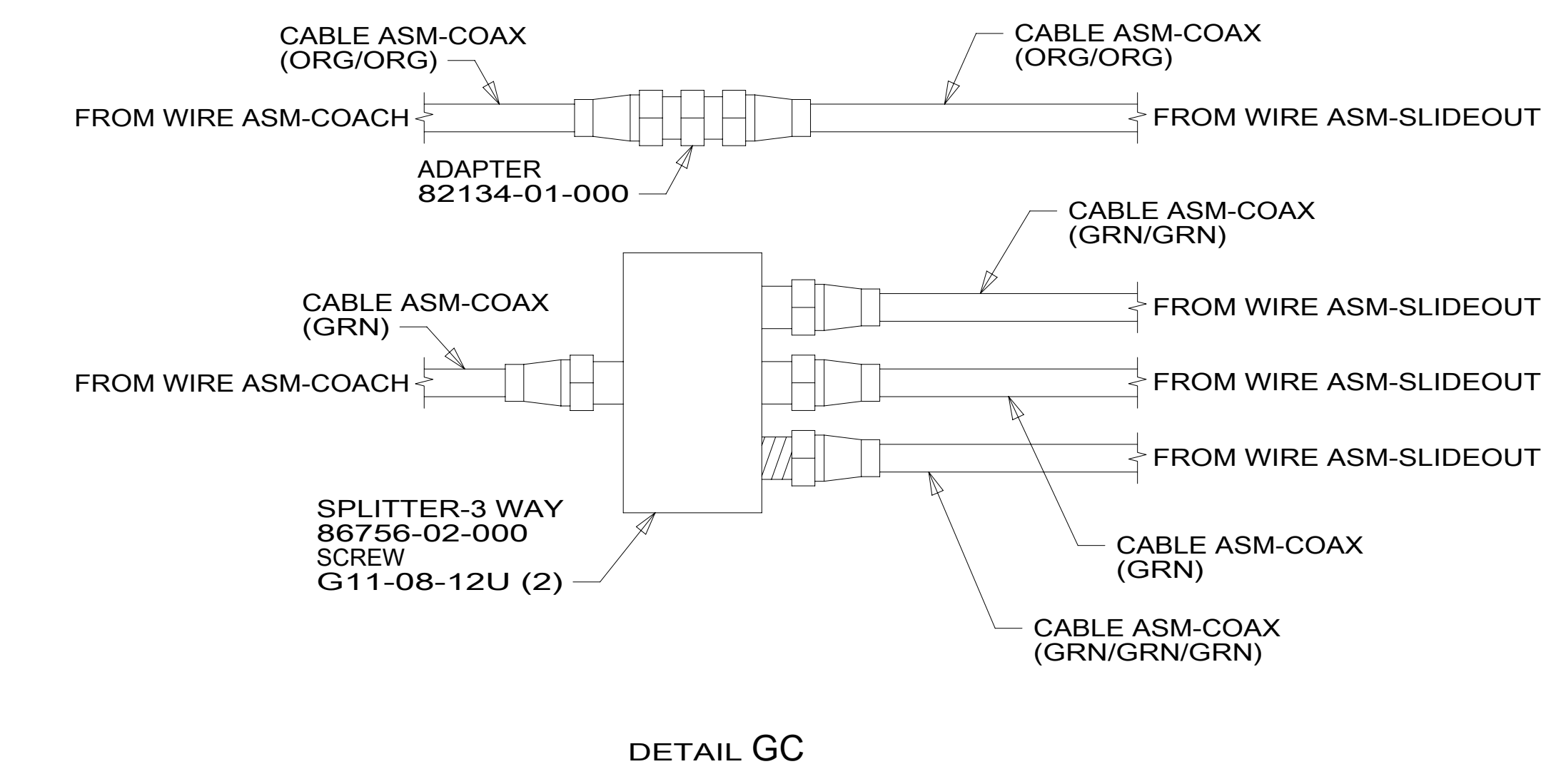
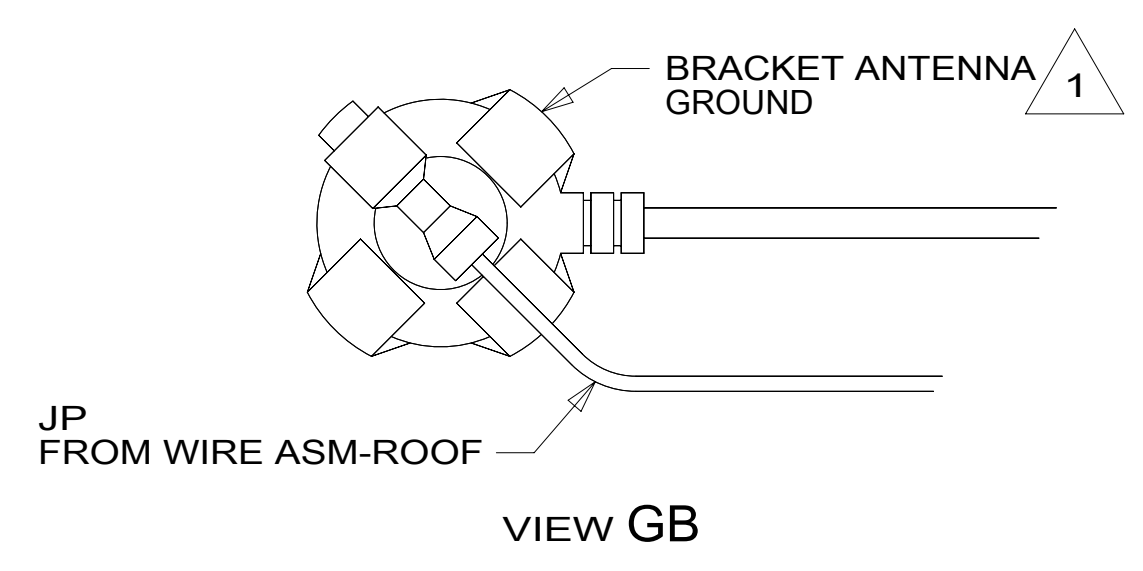
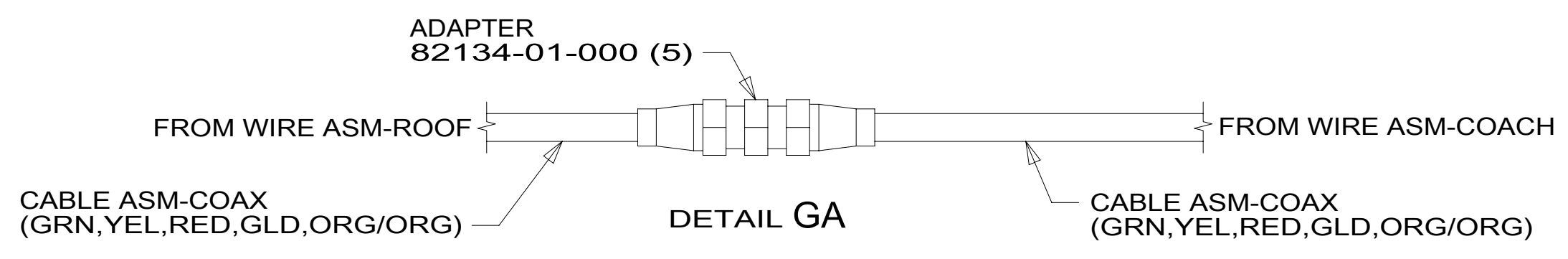

2 CONNECT THE ORANGE COAX FROM ROOF ASM TO ONE OF THE 2 GRAY COAX CABLES ON THE SATELLITE DISH, THE OTHER GRAY COAX IS NOT USED.

1 WRAP LEGS AROUND ANTENNA BASE.

NOTES:

FOR ELECTRICAL TORQUE SPECIFICATIONS SEE DWG NO. 128783-01-000

FOR ELECTRICAL CALLOUTS SEE DWG NO. 121339-01-000

- 1D3 ENTERTAIN CENTR/EXT TV-DVD
- 48Q SATELLITE TV SYSTEM MANUAL
- 265 CODES/STANDARDS-CSA/CMVSS
- 1B1 CODES/STANDARDS USA

DESCRIPTION:		1B1 265	
WIRING INSTL-BODY, 12V			
SHEET:	ITEM/PART NO.:	REV	
7 OF 9	000179682 / 30053501000		

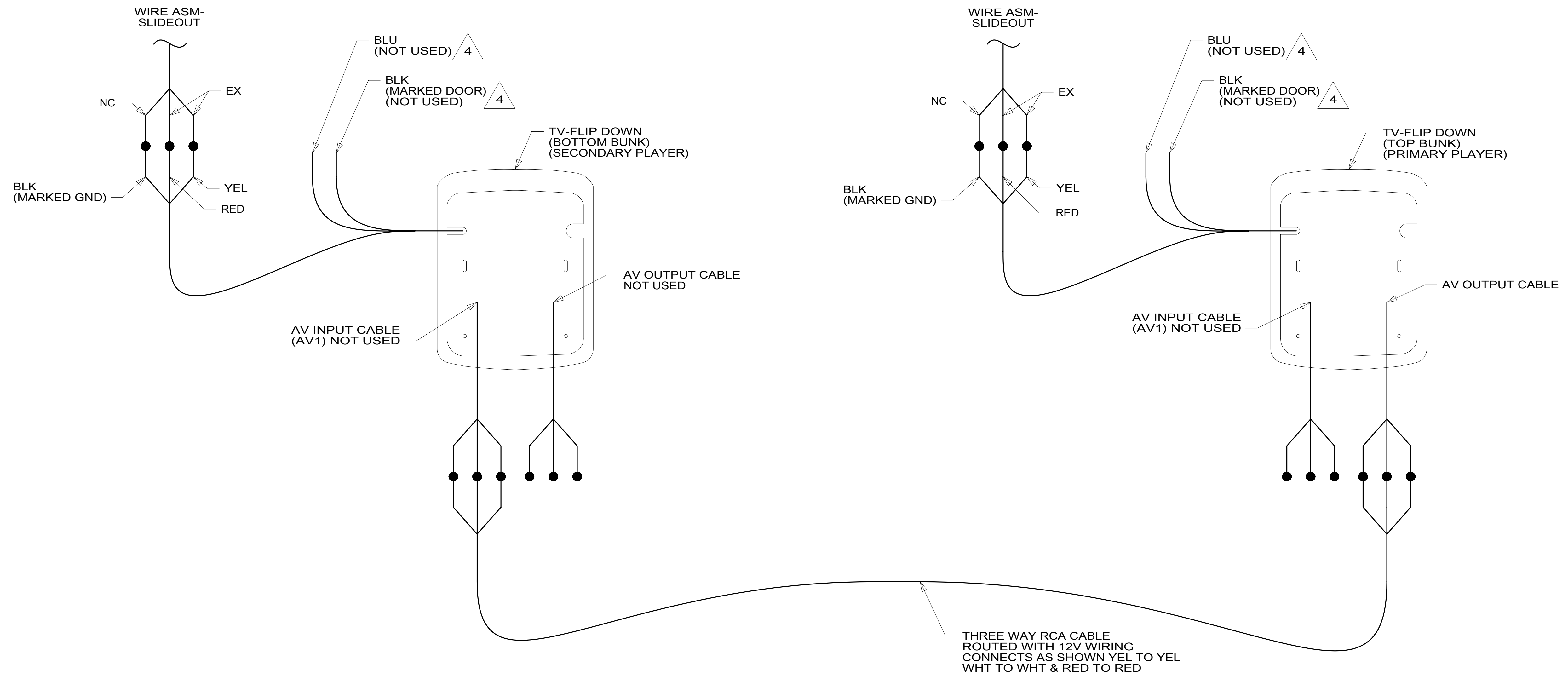

DETAIL HA 10C

4 CRIMP BUTT CONNECTOR 112823-01-000 ON THE END OF UNUSED WIRES.

- 3. REMOVE SHIPPING RESTRAINT SCREWS FROM DVD PLAYER AND DISCARD STEEL MOUNTING PLATE.
- 2. REMOVE IR RECEIVER SUPPLIED WITH DVD PLAYER, TO BE MOUNTED IN BOTTOM BUNK.

- 1. AT MINIMUM ALL WIRES TO BE SUPPORTED AND SECURED PER CODE REQUIREMENTS. USE CLAMP 10495 OR 10497 OR WIRE TIE 8343 OR 108046 AND SCREW G67-XX-XXX OR G56-XX-XXX AS APPROPRIATE FOR INSTALLATION.

NOTES:

- 10C DVD PLAYER W/7" MONITOR
- 265 CODES/STANDARDS-CSA/CMVSS
- 1B1 CODES/STANDARDS USA

FOR ELECTRICAL TORQUE SPECIFICATIONS SEE DWG NO. 128783-01-000

FOR ELECTRICAL CALLOUTS SEE DWG NO. 121339-01-000

DESCRIPTION:	
WIRING INSTL-BODY, 12V	
SHEET:	ITEM/PART NO. REV
8 OF 9	000179682 / 30053501000

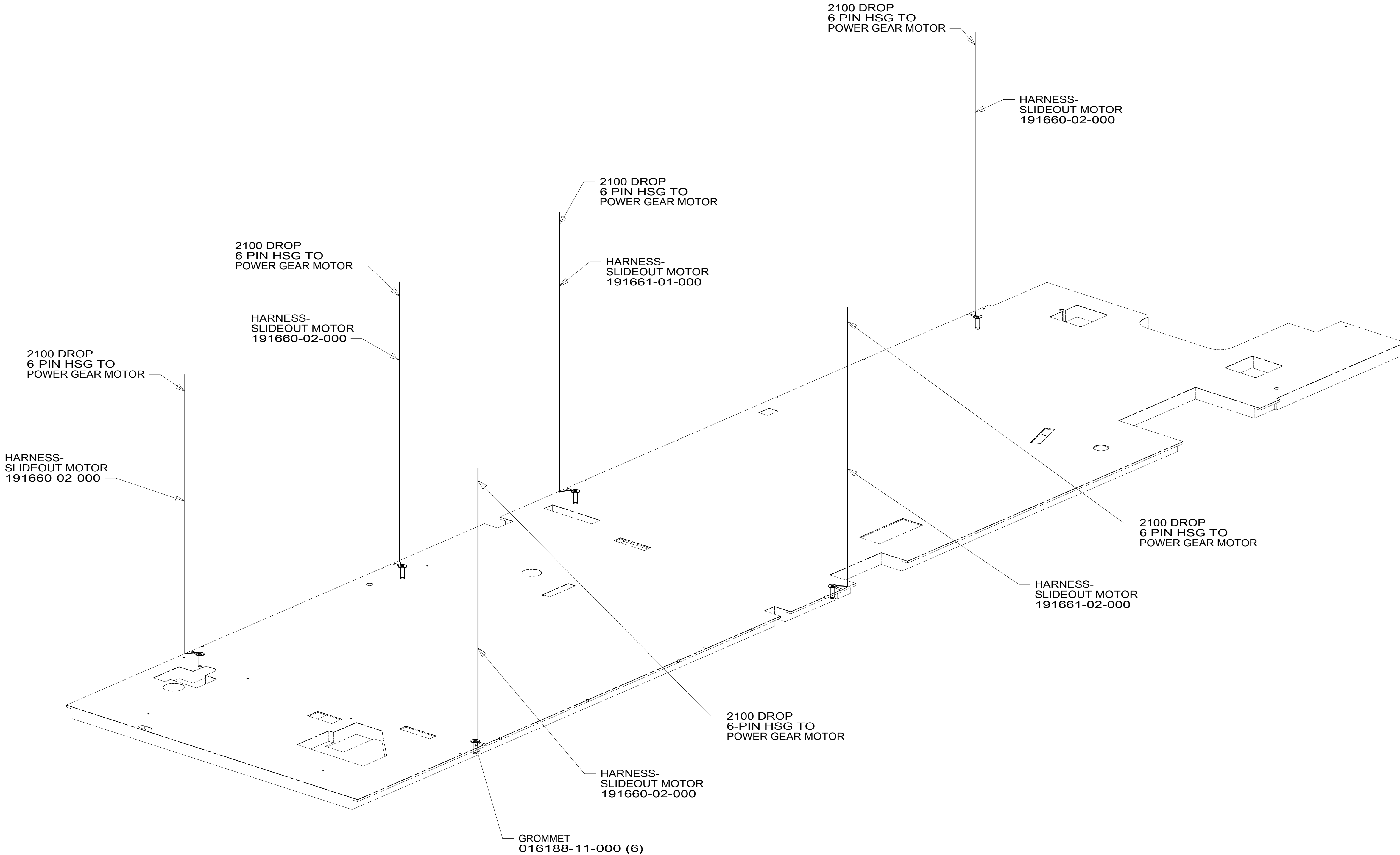
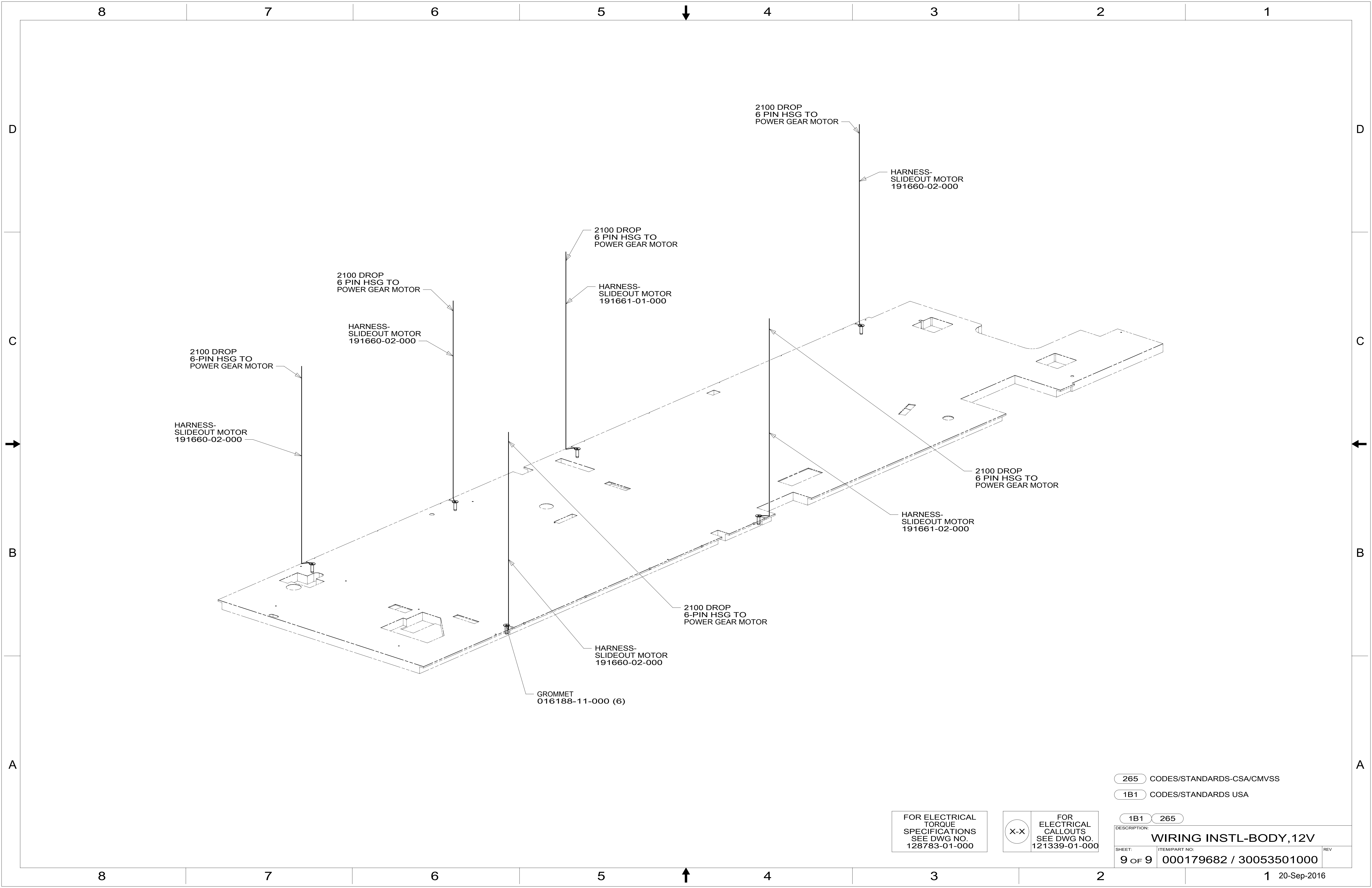

265 CODES/STANDARDS-CSA/CMVSS

1B1 CODES/STANDARDS USA

1B1 265

FOR ELECTRICAL TORQUE SPECIFICATIONS SEE DWG NO. 128783-01-000

FOR ELECTRICAL CALLOUTS SEE DWG NO. 121339-01-000

DESCRIPTION:		
WIRING INSTL-BODY, 12V		
SHEET:	ITEM/PART NO.:	REV
9 OF 9	000179682 / 30053501000	