

- 9. SEE DRAWING 061607 FOR INSTALLATION OF GROMMETS.
- 8. SECURE DRAINAGE PIPES TO CABINET USING WIRE TIE 108046-02-000, AND SCREW 000G67-10-12U AT INTERVALS OF NOT OF NOT MORE THAN 4 FEET APART.
- 7. SECURE VENT PIPE TO FLOOR WITH CLAMP 062401-02-000 (2), SCREW 000G67-10-12U (2), BRACKET 136878-01-CHT (2).
- 6. VENT PIPE MUST PROJECT 51 MIN AND 64 MAX ABOVE ROOF FOR PROPER FIT AND FUNCTION. ADD S-1 (116666-01-CHT SEAL-VENT PIPE) AROUND PIPE ON ROOF BEFORE VENT CAP IS INSTALLED.
- 5. SEAL AROUND SHOWER WITH SILICONE.
- 4. USE SMOOTH PLUMBERS PUTTY 167459-01-000 TO SEAL STRAINER (0.2 PER STRAINER).
- 3. ALL PIPE AND FITTINGS TO BE ASSEMBLED WITH SOLVENT 004020-01-000 (USA), 004020-02-000 (CAN)
- 2. SLOPE OF TRAP ARM MUST BE 6 PER 305 mm.
- 1. SLOPE OF HORIZONTAL PIPING TO BE MINIMUM OF 3 PER 305 mm.

NOTES:

- 265 CODES/STDS-CSA/CMVSS
- 1B1 CODES/STANDARDS-USA



| | | | |
|--|-------------------------|-----------------------------------|-------------------|
| DSNR: | | ALL DIMENSIONS ARE IN MILLIMETERS | |
| DIFTR: | | MATERIAL: | |
| UNSPECIFIED TOLERANCES: | | | |
| WHOLE DIM (X) | : 3 | | |
| ONE-PLACE (X.X) | : 1.5 | | |
| TWO-PLACE (X.XX) | : 0.50 | | |
| ANGLE | : 1° | | |
| REFER TO ES0018 FOR FASTENER TIGHTENING GUIDELINES | | WEIGHT: (LBS) | FIRST USED: (REF) |
| | | | 17 E31KE |
| DESCRIPTION: DRAINAGE SYSTEM INSTL | | | |
| SHEET: | ITEM/PART NO: | REV | |
| 1 OF 3 | 000179655 / 30045601000 | | |

X-X
FOR DRAINAGE CALLOUTS SEE DWG NO. 000211962 / 303370-01-000

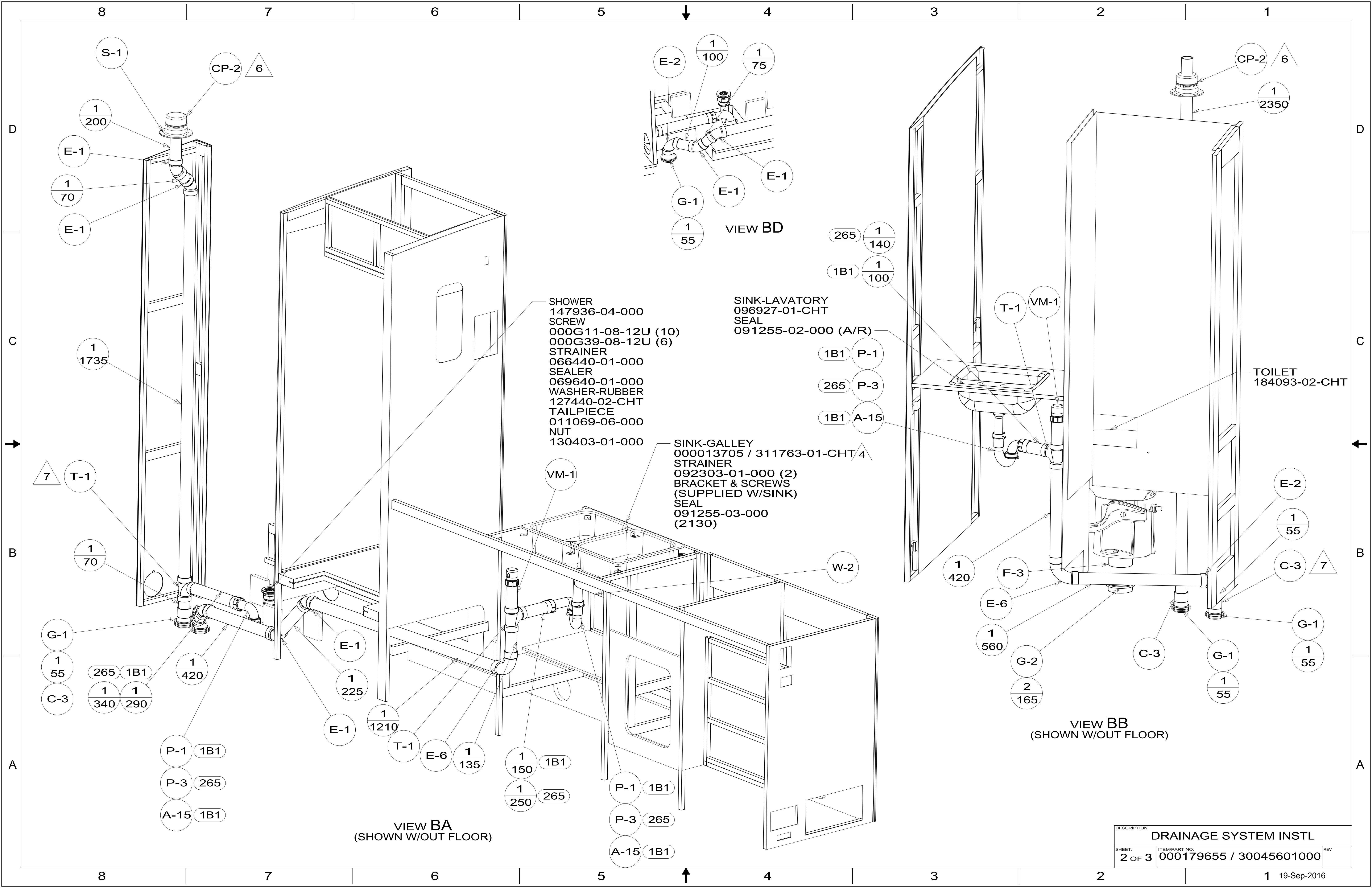

- SHOWER
 147936-04-000
 SCREW
 000G11-08-12U (10)
 000G39-08-12U (6)
 STRAINER
 066440-01-000
 SEALER
 069640-01-000
 WASHER-RUBBER
 127440-02-CHT
 TAILPIECE
 011069-06-000
 NUT
 130403-01-000

- SINK-LAVATORY
 096927-01-CHT
 SEAL
 091255-02-000 (A/R)

- SINK-GALLEY
 000013705 / 311763-01-CHT 4
 STRAINER
 092303-01-000 (2)
 BRACKET & SCREWS
 (SUPPLIED W/SINK)
 SEAL
 091255-03-000
 (2130)

VIEW BA
(SHOWN W/OUT FLOOR)

VIEW BD

VIEW BB
(SHOWN W/OUT FLOOR)

| | | |
|-----------------------|-------------------------|-----|
| DESCRIPTION: | | |
| DRAINAGE SYSTEM INSTL | | |
| SHEET: | ITEM/PART NO.: | REV |
| 2 OF 3 | 000179655 / 30045601000 | |

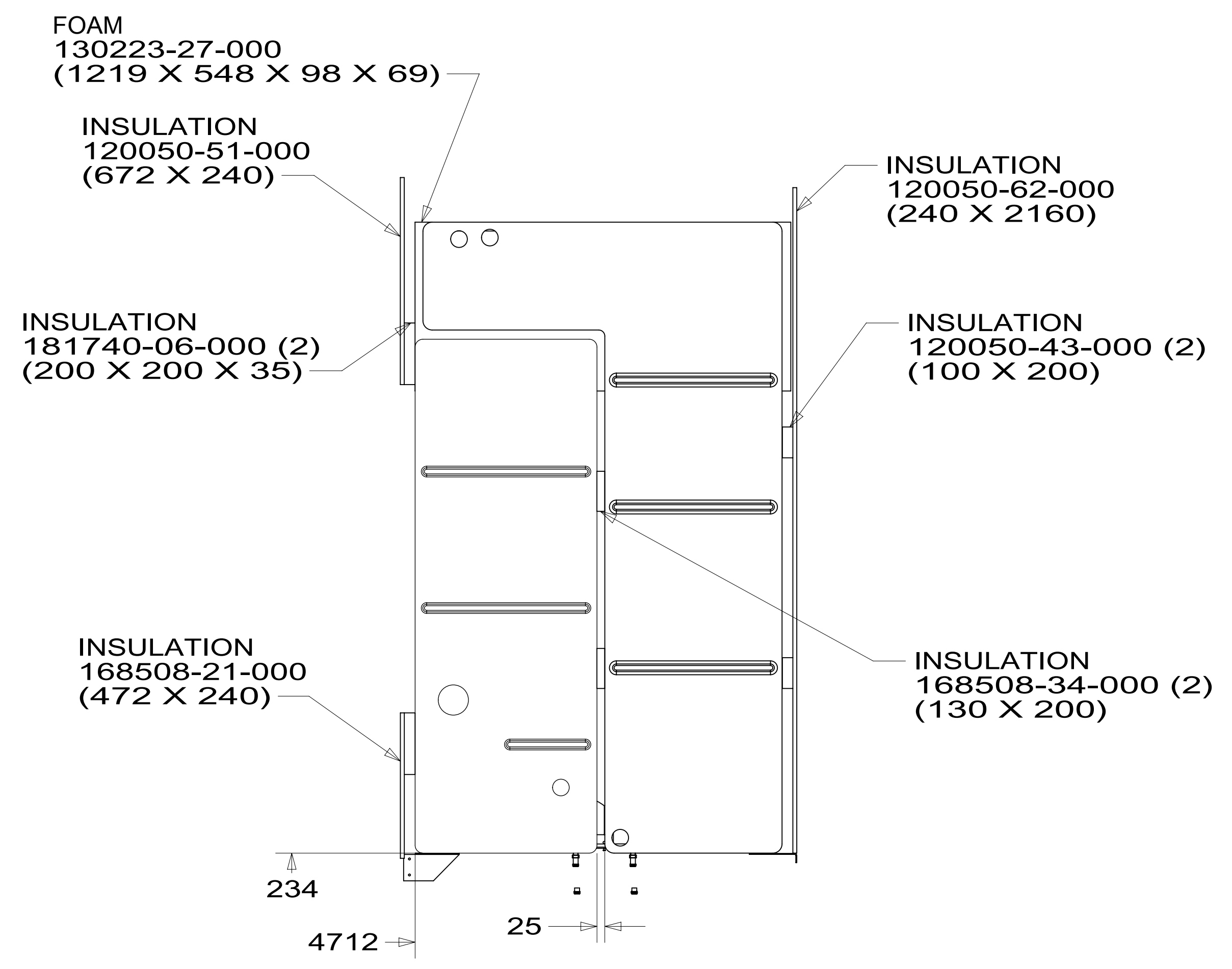
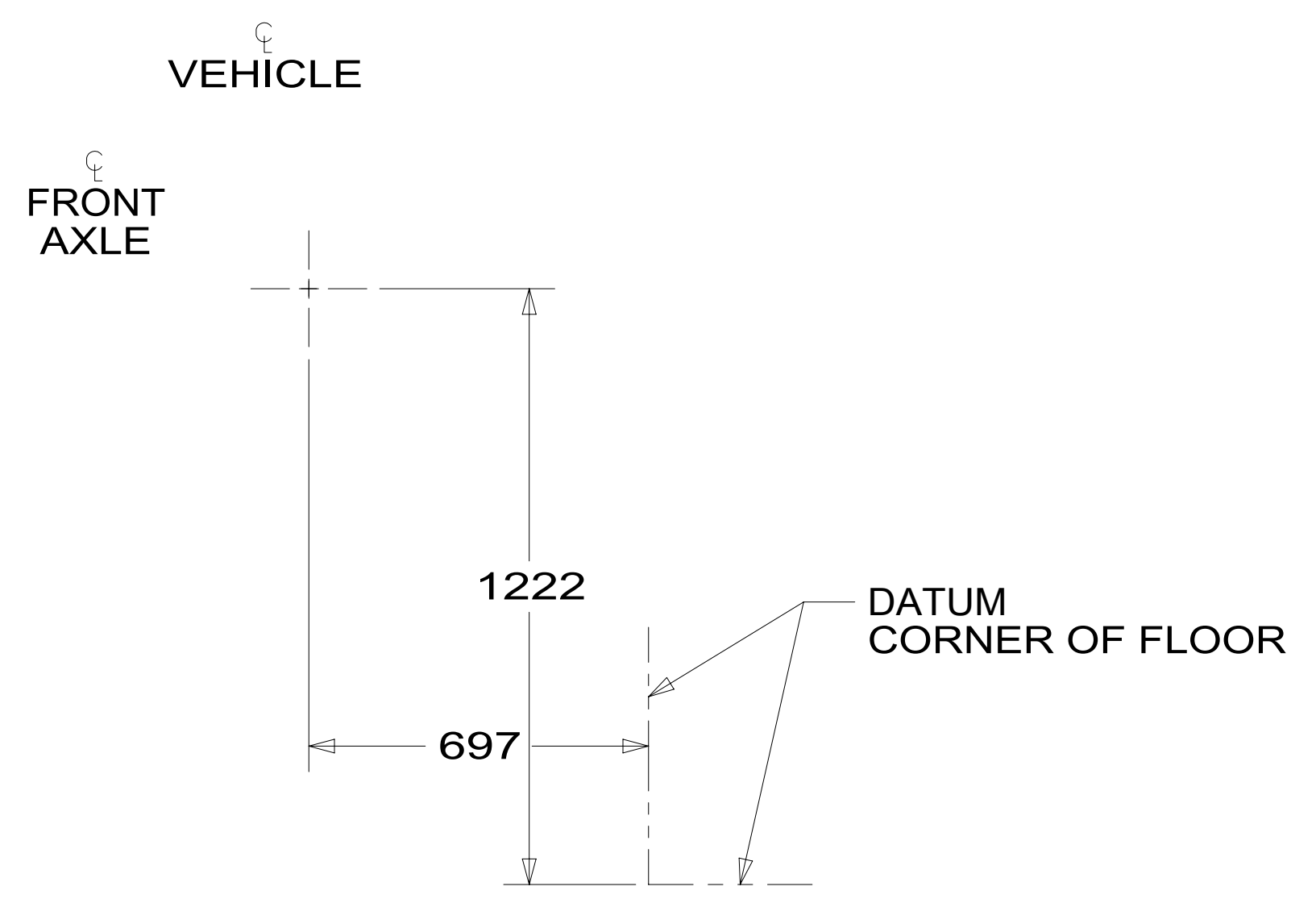
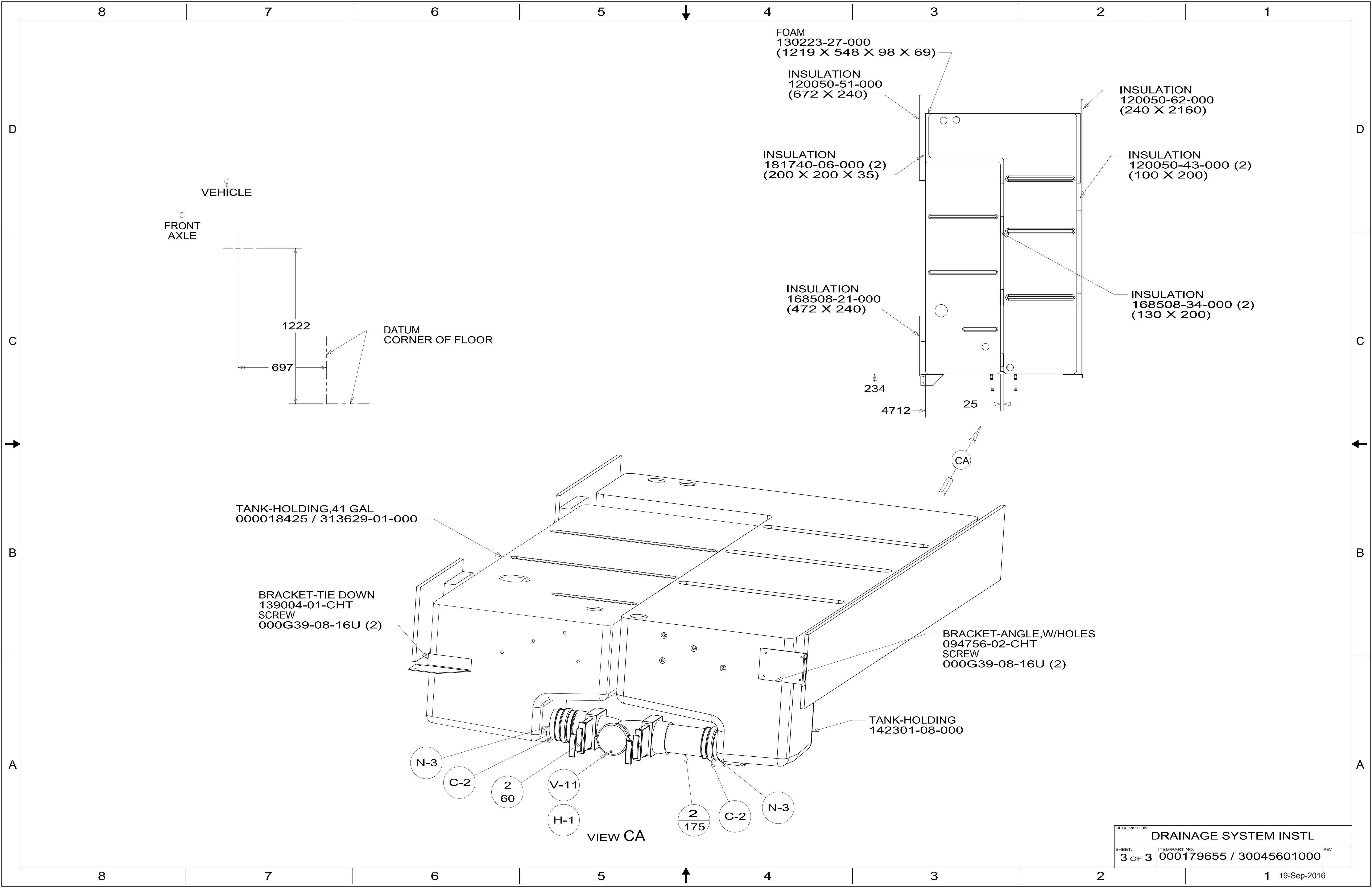

TANK-HOLDING, 41 GAL
000018425 / 313629-01-000

BRACKET-TIE DOWN
139004-01-CHT
SCREW
000G39-08-16U (2)

BRACKET-ANGLE, W/HOLES
094756-02-CHT
SCREW
000G39-08-16U (2)

TANK-HOLDING
142301-08-000

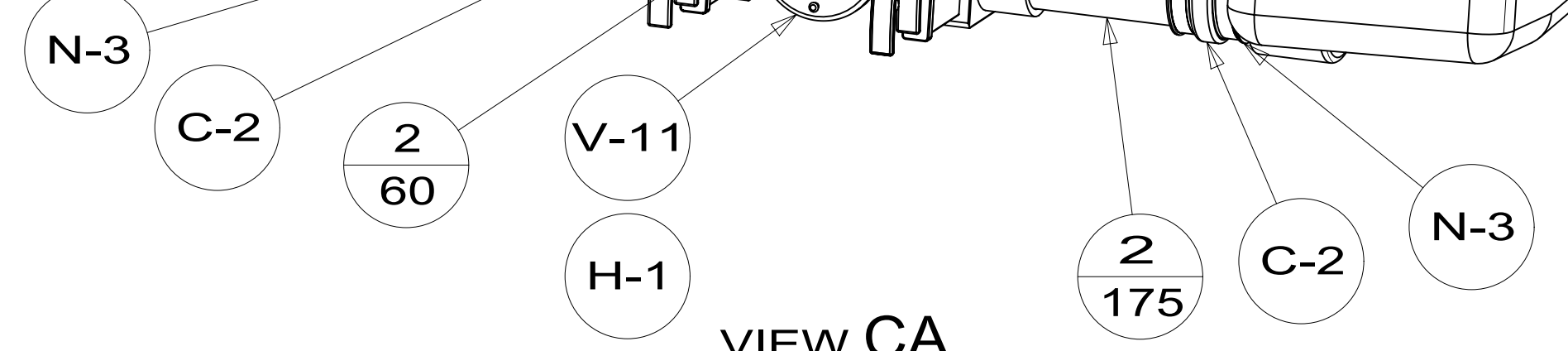

| | | |
|-----------------------|-------------------------|-----|
| DESCRIPTION: | | |
| DRAINAGE SYSTEM INSTL | | |
| SHEET: | ITEM/PART NO.: | REV |
| 3 OF 3 | 000179655 / 30045601000 | |