

- PANEL-RECEPTACLE 151376-01-CHT SCREW G67-10-12B (4)
- PANEL-RECEPTACLE 151376-02-CHT LABEL-COAX 157486-01-CHT ADAPTER 82134-01-000 NUT 82136-01-000 SCREW G67-10-12B (4)

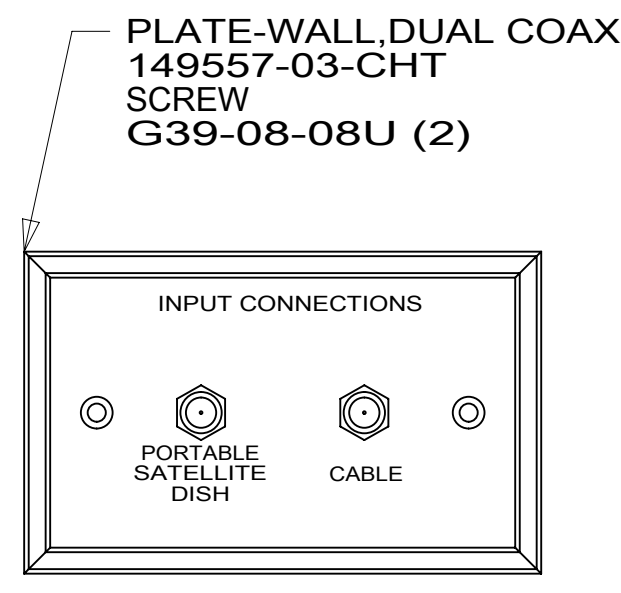

- 1DG EXT ENTERTAIN CTR W/TV & CD
- 299 ENTERTAINMENT CENTER EXT.W/O
- 265 CODES/STANDARDS-CSA/CMVSS
- 1B1 CODES/STANDARDS USA

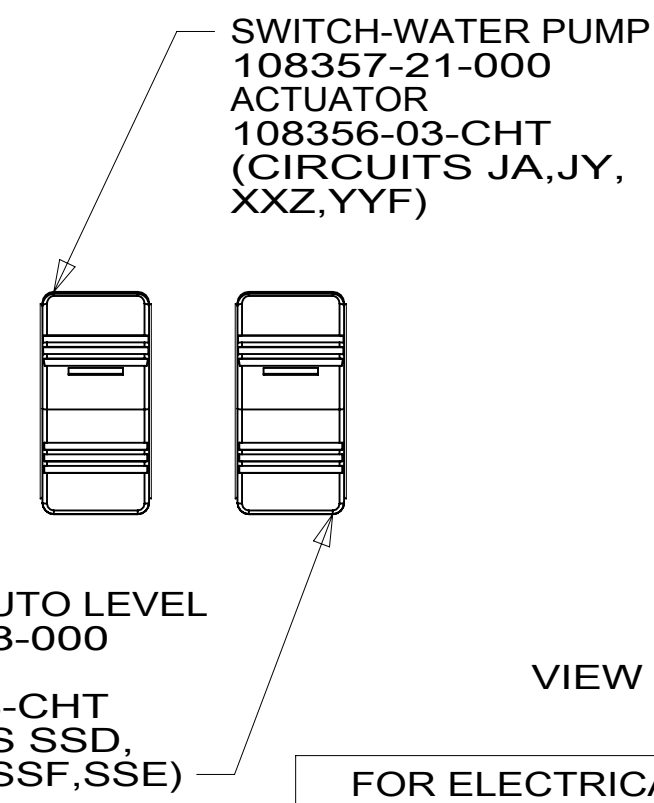
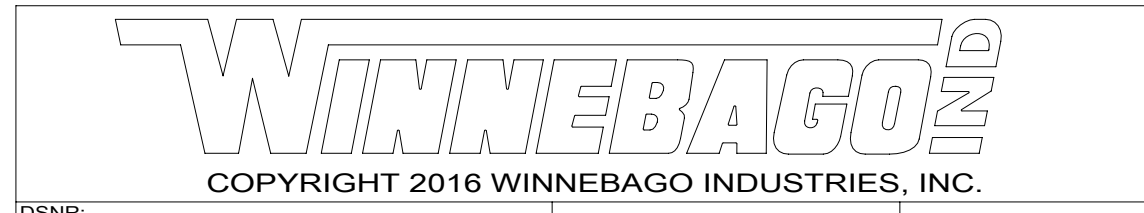

DSNR:	ALL DIMENSIONS ARE IN MILLIMETERS
DFFR:	
UNSPECIFIED TOLERANCES:	MATERIAL:
WHOLE DIM (X) : 3	
ONE-PLACE (X.X) : 1.5	
TWO-PLACE (X.XX) : 0.50	
ANGLE : 1°	
REFER TO ES0018 FOR FASTENER TIGHTENING GUIDELINES	WEIGHT: (LBS) FIRST USED: 16 D35G

DESCRIPTION: WIRING INSTL-BODY, 12V		
SHEET: 1 OF 7	ITEM/PART NO: 000179485 / 30036501000	REV:

- 4 WIRE PASSES THROUGH FLOOR IN THIS AREA.
- 3 PLACE CROSS LOCATOR ON SENSOR OVER DIMPLES ON TANK.

2. ROUTE TANK SENSOR WIRES SO THEY DO NOT PASS OVER SENSORS. USE WIRE TIE MOUNT 155366-01-000 AND WIRE TIE 8343-01-000 AS NEEDED. TANK SURFACE MUST BE CLEANED USING ISOPROPYL ALCOHOL AND PRIMED WITH PRIMER 94.

1. AT MINIMUM ALL WIRES TO BE SUPPORTED AND SECURED PER CODE REQUIREMENTS. USE CLAMP 10495 OR 10497 OR WIRE TIE 8343 OR 108046 AND SCREW G67-XX-XXX OR G56-XX-XXX AS APPROPRIATE FOR INSTALLATION.

NOTES:

FOR ELECTRICAL TORQUE SPECIFICATIONS SEE DWG NO. 128783-01-000

FOR ELECTRICAL CALLOUTS SEE DWG NO. 121339-01-000

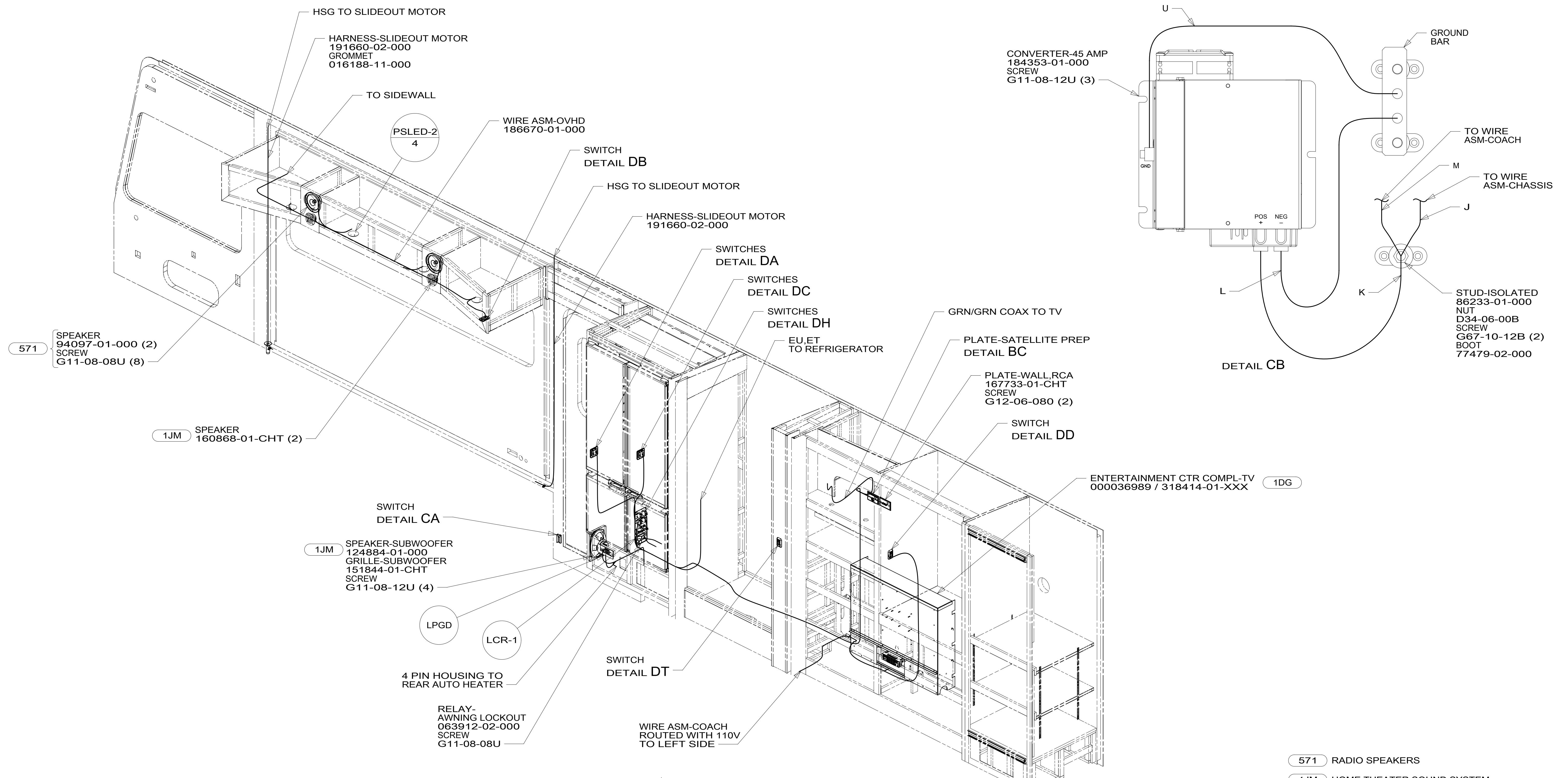

- 4 REMOVE SCREWS FROM MAGNET SWITCH TO INSTALL LOCK WASHER AND RING TERMINALS.
 - 3 MOUNT MAGNET USING PILOT HOLES IN SCREEN DOOR FRAME, MOUNT WITH MAGNET TOWARD SWITCH.
 - 2 MOUNT SWITCH AND SPACER TO BLOCK ON JAMB, ADJUST HEIGHT TO MATCH MAGNET.
1. AT MINIMUM ALL WIRES TO BE SUPPORTED AND SECURED PER CODE REQUIREMENTS. USE CLAMP 10495 OR 10497 OR WIRE TIE 8343 OR 108046 AND SCREW G67-XX-XXX OR G56-XX-XXX AS APPROPRIATE FOR INSTALLATION.

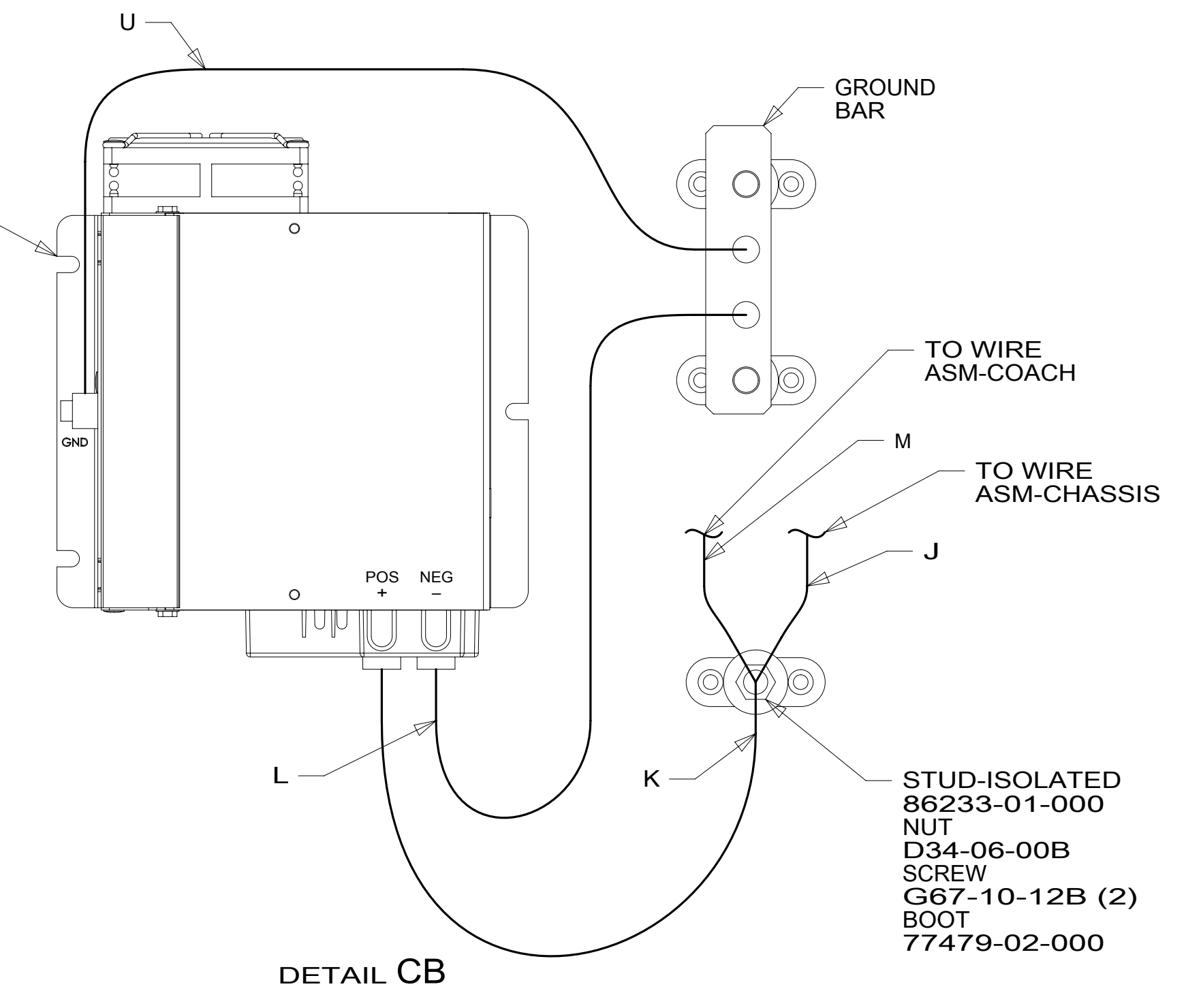
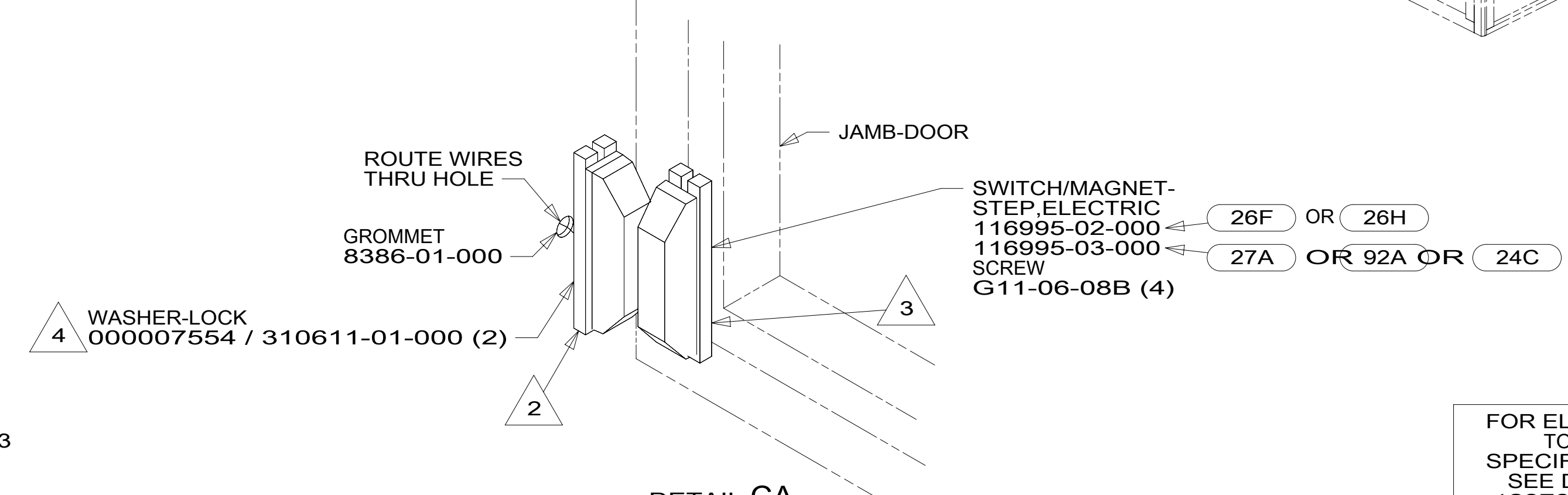

- 571 RADIO SPEAKERS
- 1JM HOME THEATER SOUND SYSTEM
- 92A EXT FULL BODY PAINT PKG # 2
- 27A EXT FULL BODY PAINT PKG #1
- 26H EXT GRAPHIC/PAINT-DLX PKG 2
- 26F EXT GRAPHIC/PAINT DLX PKG 1
- 24C EXT FULL BODY PAINT PKG # 3
- 1DG EXT ENTERTAIN CTR W/TV & CD
- 265 CODES/STANDARDS-CSA/CMVSS
- 1B1 CODES/STANDARDS USA

FOR ELECTRICAL TORQUE SPECIFICATIONS SEE DWG NO. 128783-01-000

FOR ELECTRICAL CALLOUTS SEE DWG NO. 121339-01-000

DESCRIPTION:	1B1 265	
WIRING INSTL-BODY, 12V		
SHEET:	ITEM/PART NO:	REV
3 OF 7	000179485 / 30036501000	

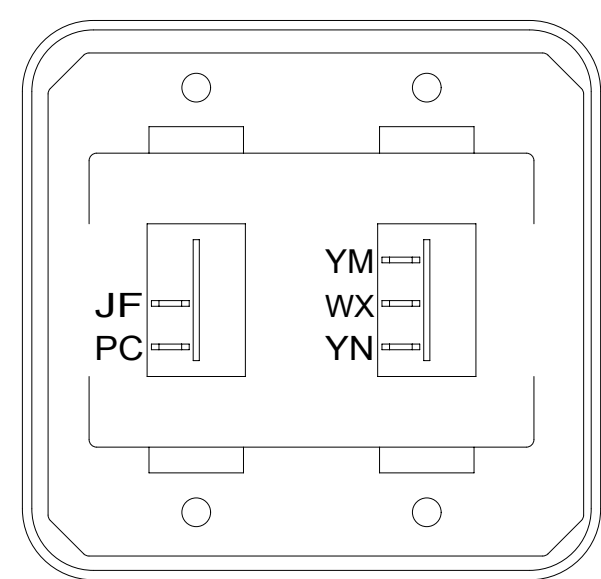

SWITCH-ROCKER
135740-01-CHT
135740-02-CHT
SWITCH-BASE
135741-02-CHT
SWITCH-BEZEL
135742-02-CHT
SCREW
G11-08-08U (4)

DETAIL DA

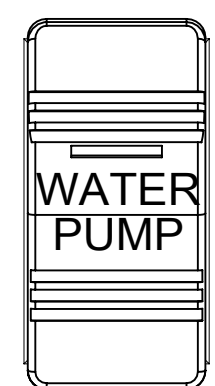

DETAIL DF

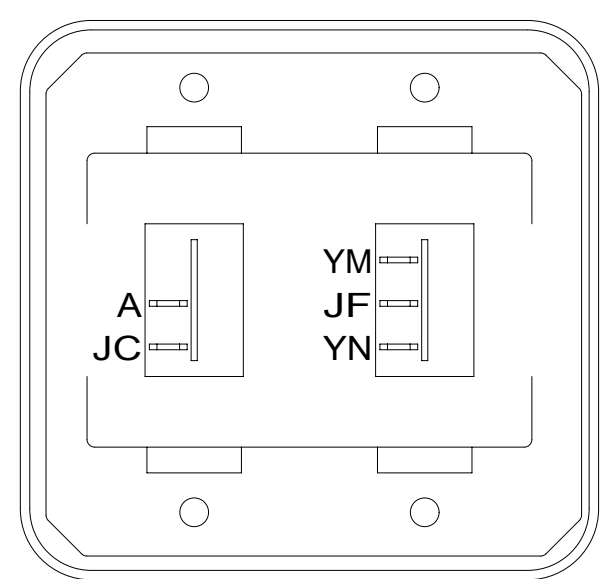

SWITCH-ROCKER
135740-01-CHT
135740-02-CHT
SWITCH-BASE
135741-02-CHT
SWITCH-BEZEL
135742-02-CHT
SCREW
G11-08-08U (4)

DETAIL DG

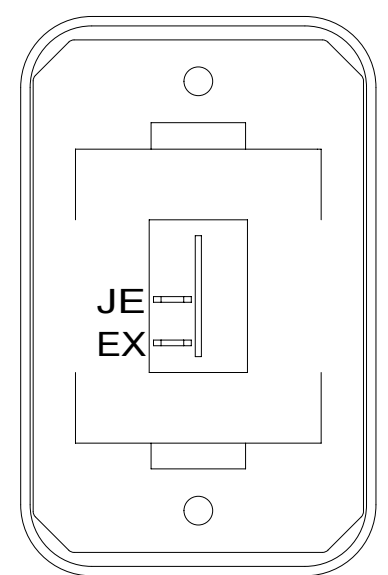

SWITCH-ROCKER
135740-01-CHT
SWITCH-BASE
135741-01-CHT
SWITCH-BEZEL
135742-01-CHT
SCREW
G11-08-08U (2)

DETAIL DB

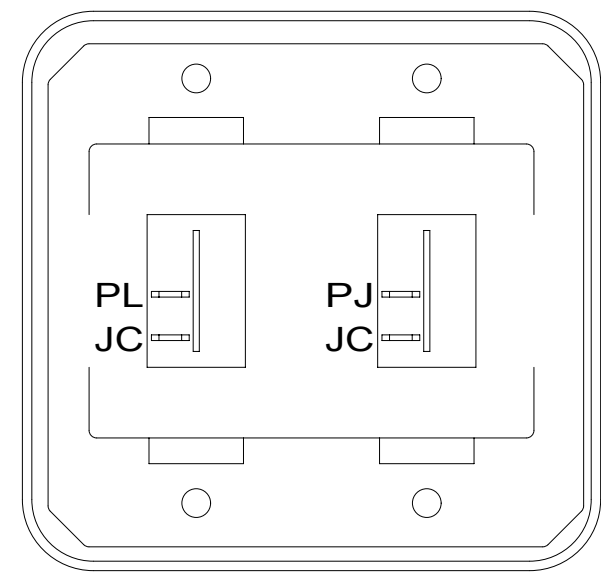

SWITCH-ROCKER
135740-01-CHT (2)
SWITCH-BASE
135741-02-CHT
SWITCH-BEZEL
135742-02-CHT
SCREW
G11-08-08U (4)

DETAIL DC

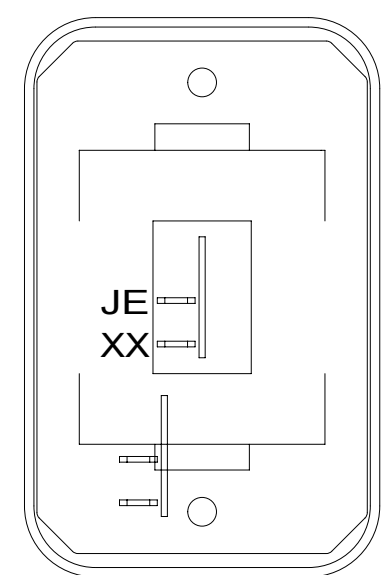

SWITCH-ROCKER
135740-01-CHT
SWITCH-BASE
135741-01-CHT
SWITCH-BEZEL
135742-01-CHT
SCREW
G11-08-08U (2)

DETAIL DD

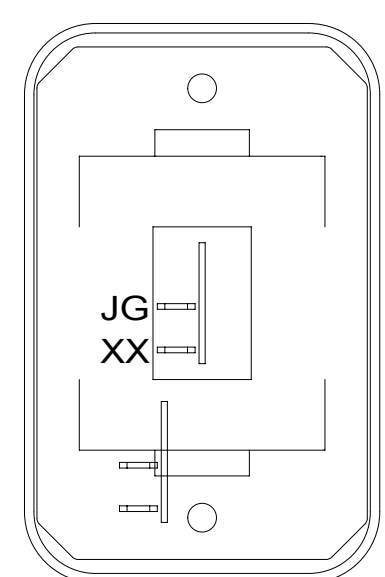

SWITCH-ROCKER
135740-01-CHT
SWITCH-BASE
135741-01-CHT
SWITCH-BEZEL
135742-01-CHT
SCREW
G11-08-08U (2)

DETAIL DE

SWITCH-AWNING
108357-06-000
ACTUATOR-SWITCH
108356-12-CHT
CIRCUITS
FFD,FFR,FFE,
FFE,JJR,FFD

SWITCH-COMT LIGHTS
108357-01-000
ACTUATOR-SWITCH
108356-14-CHT
CIRCUITS WC,NW

SWITCH-COACH BATT
108357-18-000
ACTUATOR-SWITCH
108356-19-CHT
CIRCUITS KF,LJ,LG,
LH,WC
WIRE ASM-THERM
186796-01-000

PLATE-SWITCH
158431-23-CHT
SCREW
G11-06-10U (6)

SWITCH-AWNING LIGHTS
108357-14-000
ACTUATOR-SWITCH
108356-28-CHT

SWITCH-AUTO LEVEL
108357-18-000
ACTUATOR-SWITCH
108356-15-CHT
CIRCUITS SSD,SSE,
SSC,SSE,SSF

SWITCH-STEP
108357-19-000
CIRCUITS ER,ES

SWITCH-CHASSIS BATTERY
108357-18-000
ACTUATOR-SWITCH
108356-20-CHT
CIRCUITS TTY,TTZ,MK,
UUB,UUC
WIRE ASM-THERM
186796-01-000

SWITCH-CONTROL,
LOFTBED TOUCH
189056-01-000
WIRE ASM-
LOFTBED SWITCH
190197-01-000
SCREW
076790-05-000 (2)

SWITCH
108357-06-000
ACTUATOR
108356-25-CHT

LABEL-SLIDEOUT,
PASS,FRONT
163992-04-CHT

LABEL-SLIDEOUT,
DRIVER,FRONT
163992-01-CHT

SLIDEOUT-ELEC.FRONT
171341-01-000
SCREW
76790-05-000 (2)

CONNECT TO 12-PIN
HOUSING WITH CIRCUITS
SSP,GGE,GGF,
GGD,DR,DU,VVP,VVN

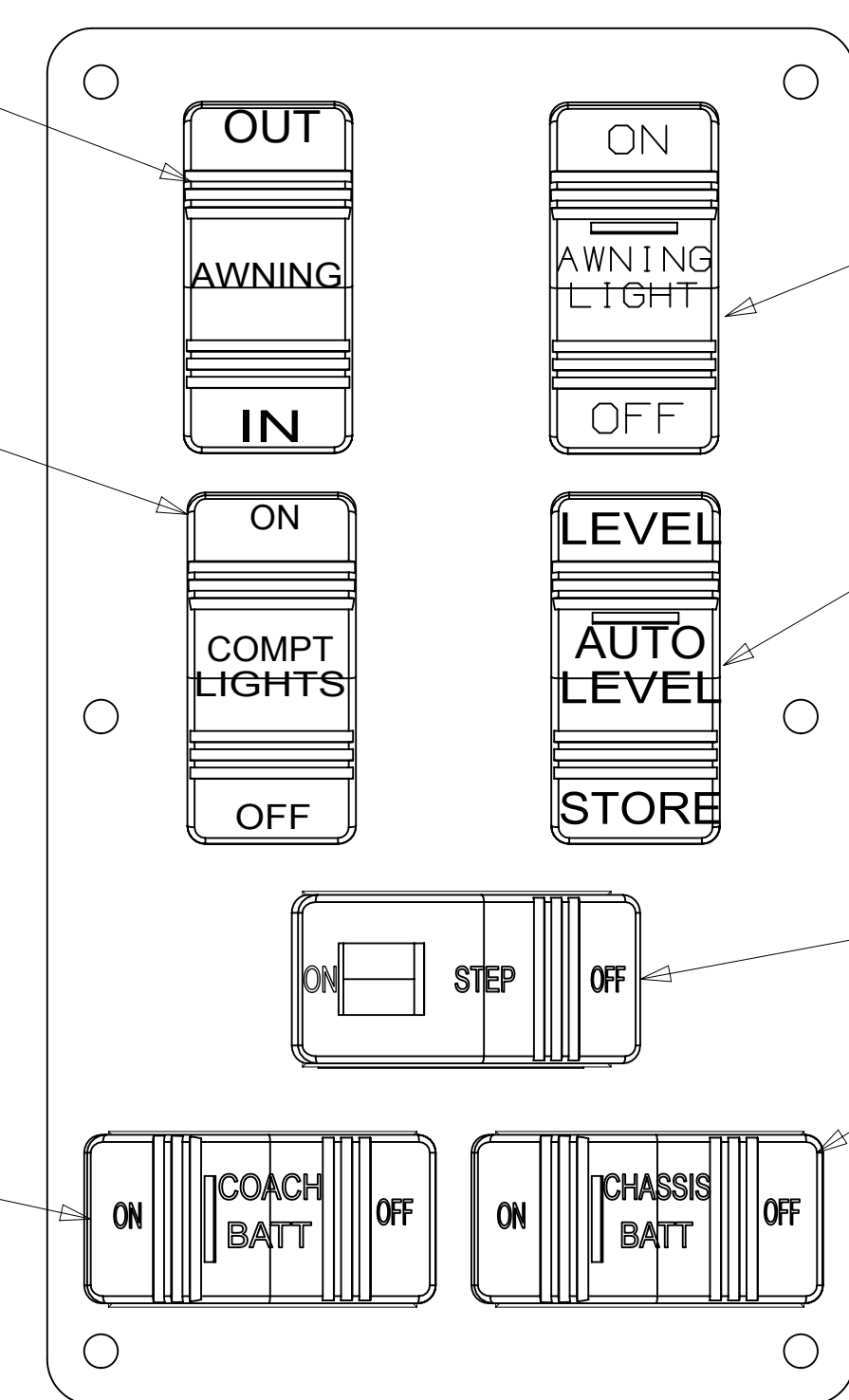

DETAIL DH 1

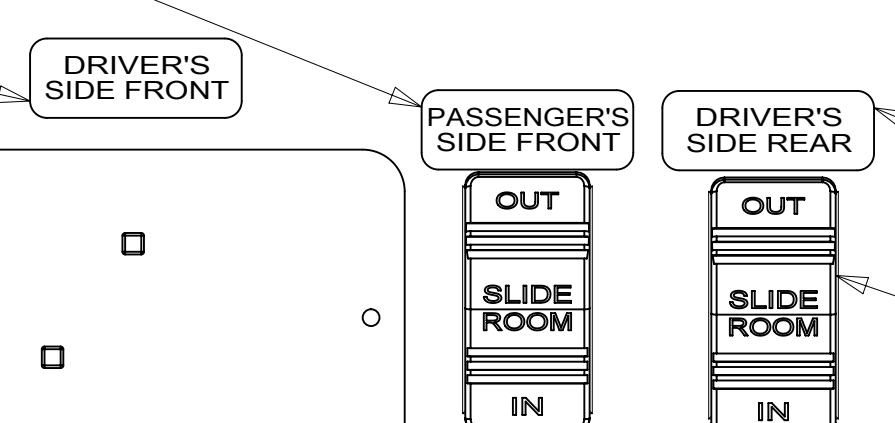
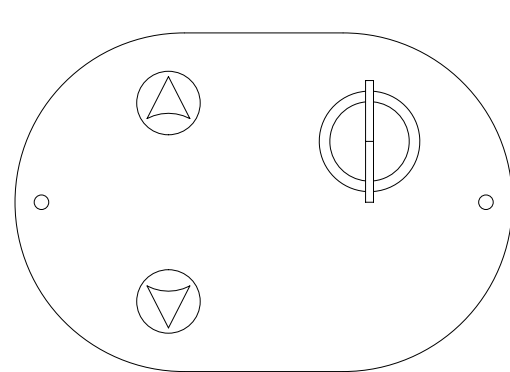

DETAIL DN

LABEL-WARNING,SLIDEOUT
116549-01-000

WARNING CRUSH HAZARD. Keep people and objects clear of the inside and the outside of the slideout room when operating. Failure to comply could result in death or serious injury.

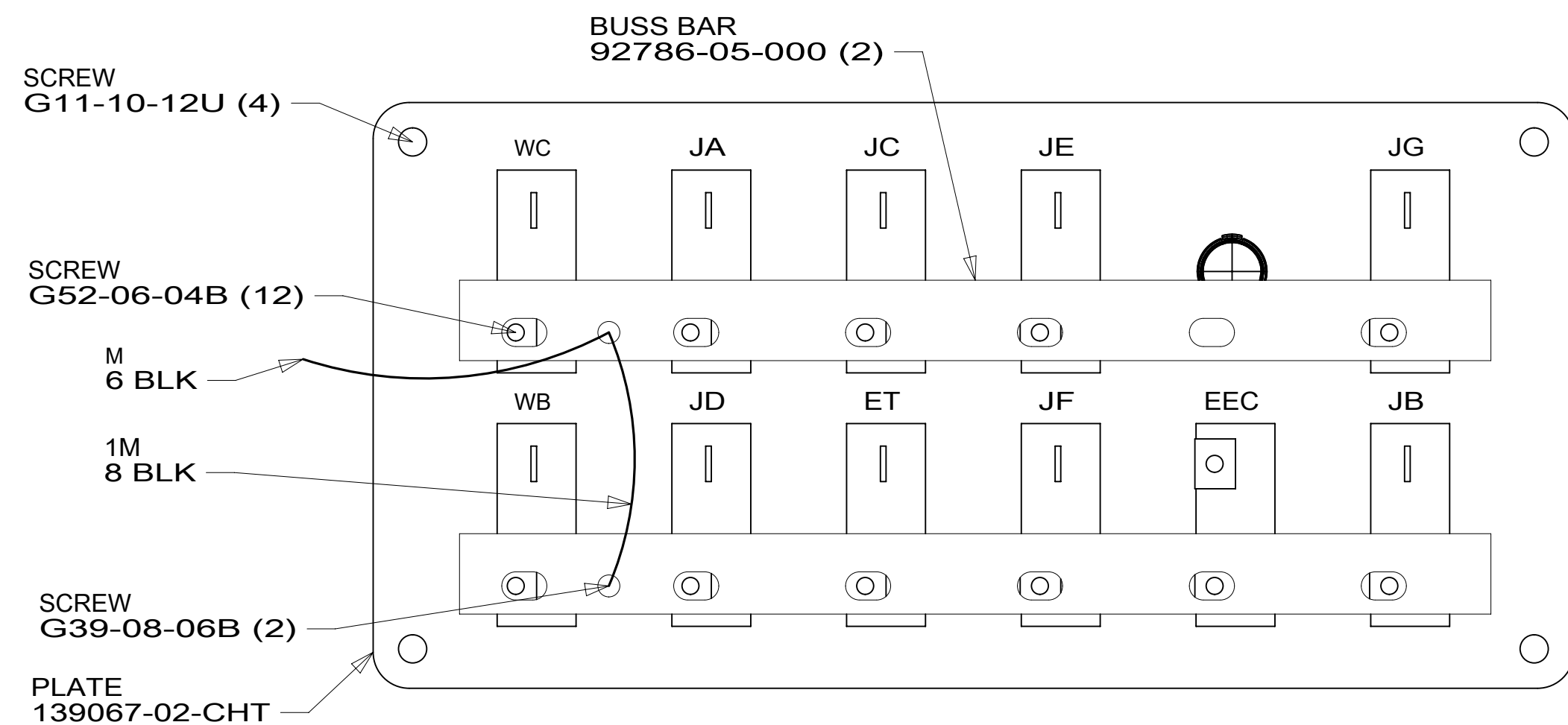

DETAIL DK
(BACK VIEW)

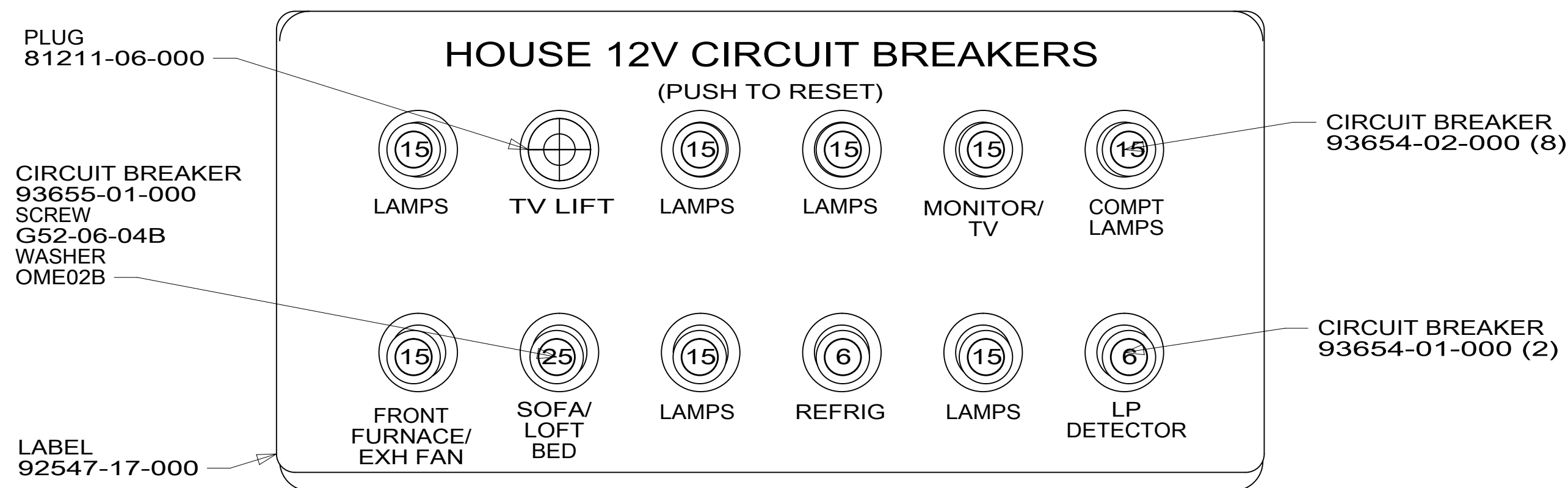

DETAIL DK
(FRONT VIEW)

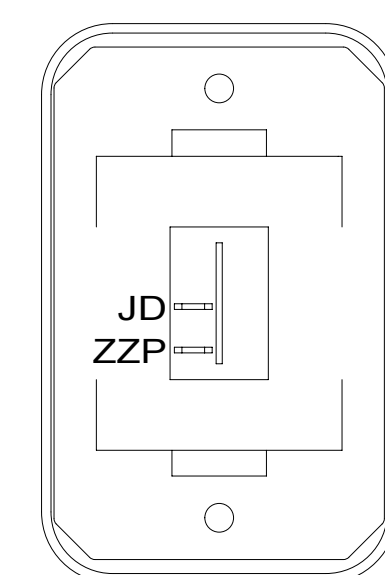

DETAIL DR

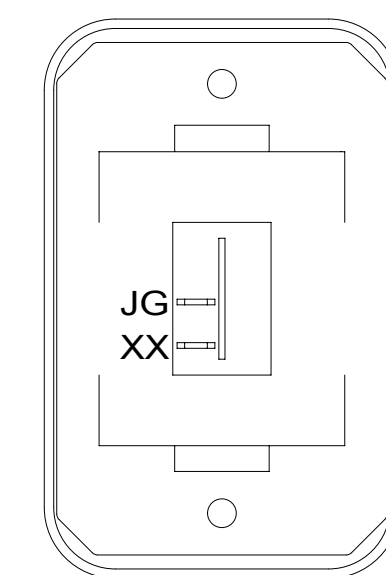

DETAIL DP

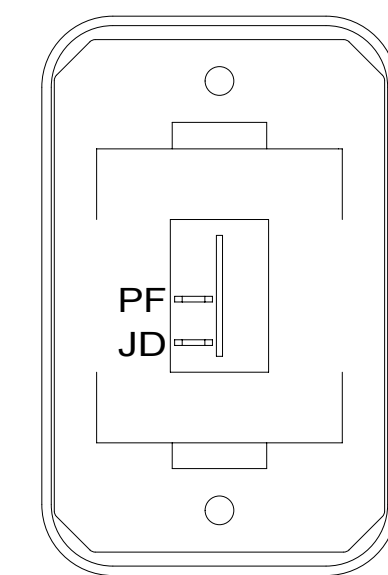

DETAIL DT

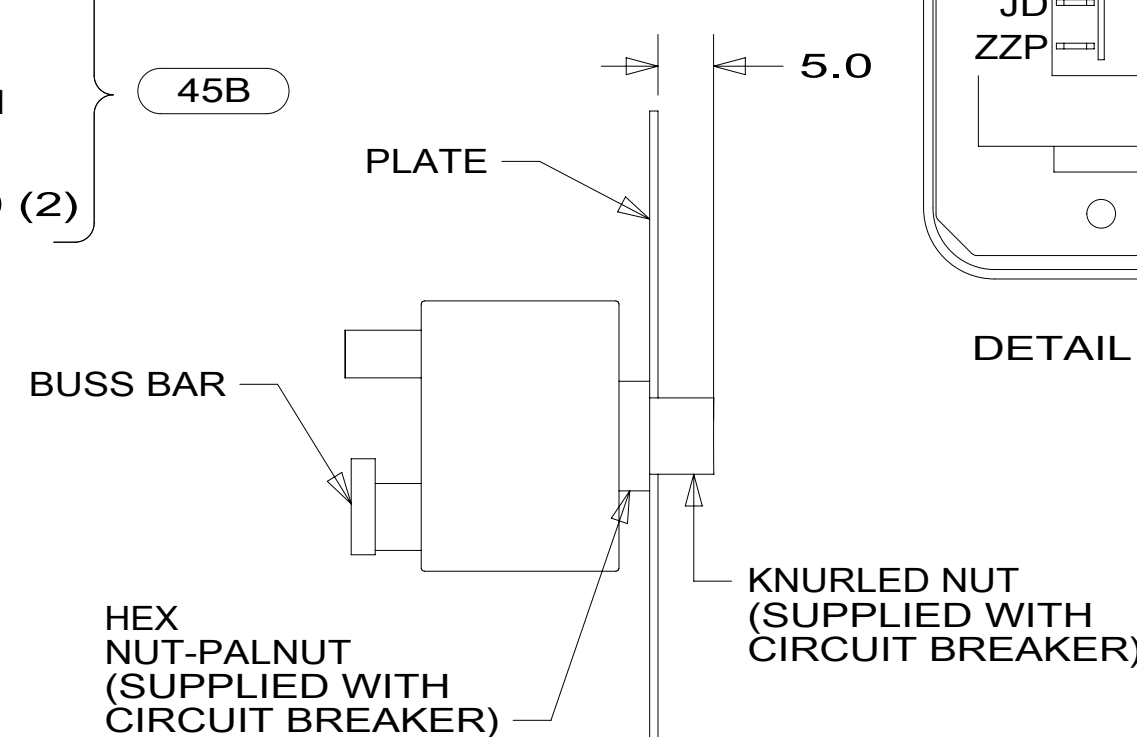

DETAIL DL

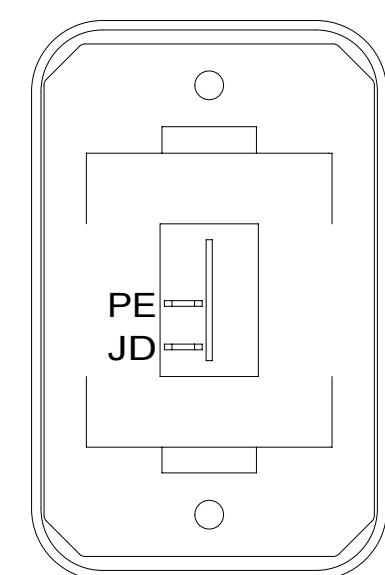

DETAIL DM

SWITCH-ROCKER
135740-01-CHT
SWITCH-BASE
135741-01-CHT
SWITCH-BEZEL
135742-01-CHT
SCREW
G11-08-08U (2)

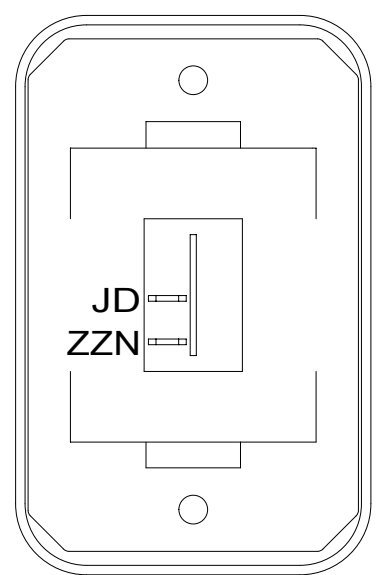

DETAIL DS

SWITCH-ROCKER
135740-01-CHT
SWITCH-BASE
135741-01-CHT
SWITCH-BEZEL
135742-01-CHT
SCREW
G11-08-08U (2)

45B LOFT BED

265 CODES/STANDARDS-CSA/CMVSS

1B1 CODES/STANDARDS USA

1B1 265

DESCRIPTION:

WIRING INSTL-BODY, 12V

SHEET:

ITEM/PART NO.:

4 OF 7 000179485 / 30036501000

REV 29-Nov-2016

NOTES:
1 FOR SWITCH ORIENTATION SEE DETAIL DJ.

FOR ELECTRICAL
TORQUE
SPECIFICATIONS
SEE DWG NO.
128783-01-000

FOR ELECTRICAL
CALLOUTS
SEE DWG NO.
121339-01-000

8 7 6 5 4 3 2 1

D

D

45B LIGHT-LED, SWIVEL W/SWITCH
190024-01-CHT

1JM SPEAKER-ROUND, CEILING
179783-01-CHT (3)
SCREW
G1208-12-170 (12)

LSH-3

LS-2

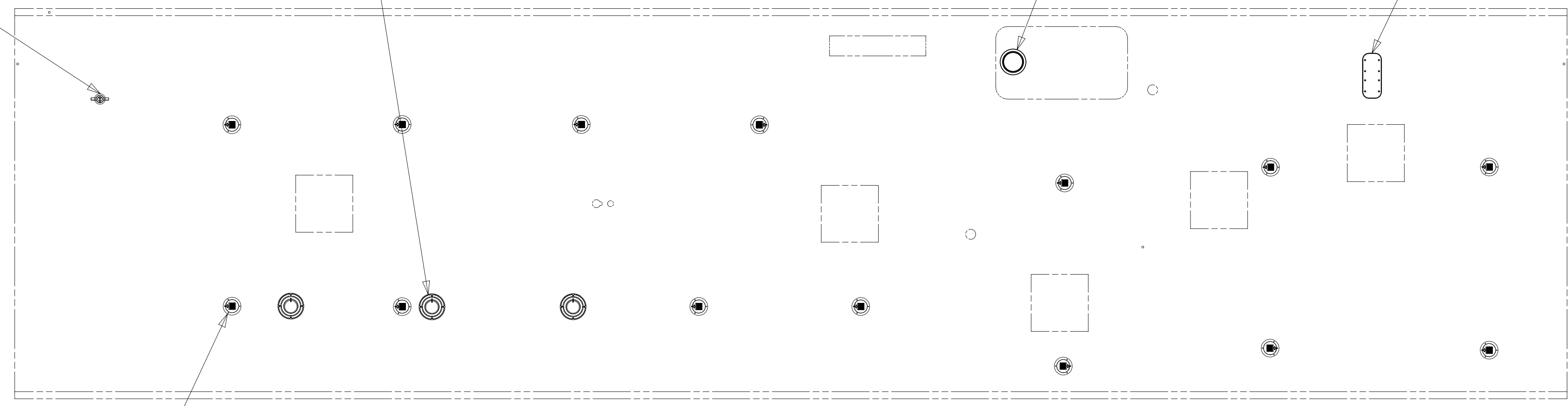

PRLED-4
14

C

C

→

←

B

B

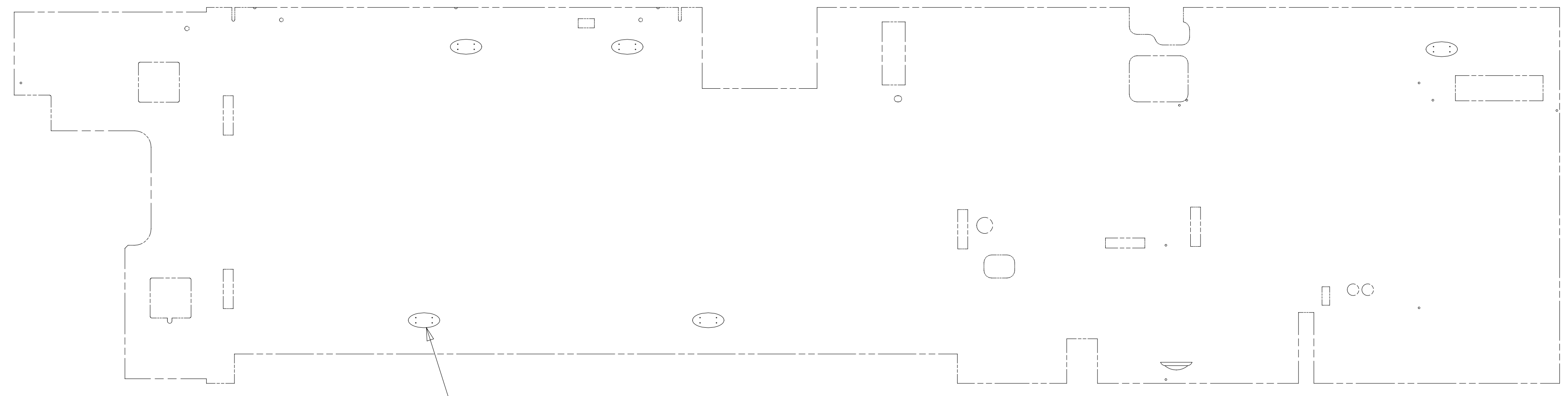

LO1-3
6

WASHER
180671-02-CHT (5)

A

A

- 45B LOFT BED
- 1JM HOME THEATER SOUND SYSTEM
- 265 CODES/STANDARDS-CSA/CMVSS
- 1B1 CODES/STANDARDS USA

FOR ELECTRICAL TORQUE SPECIFICATIONS SEE DWG NO. 128783-01-000

FOR ELECTRICAL CALLOUTS SEE DWG NO. 121339-01-000

1B1 265

DESCRIPTION: WIRING INSTL-BODY, 12V

SHEET: 5 OF 7 ITEM/PART NO: 000179485 / 30036501000 REV

8 7 6 5 4 3 2 1 29-Nov-2016

THE SATELLITE DISH WIRE CONNECTIONS ARE TO BE PLACED IN THE CENTERLINE OF THE MOTORHOME FACING FORWARD

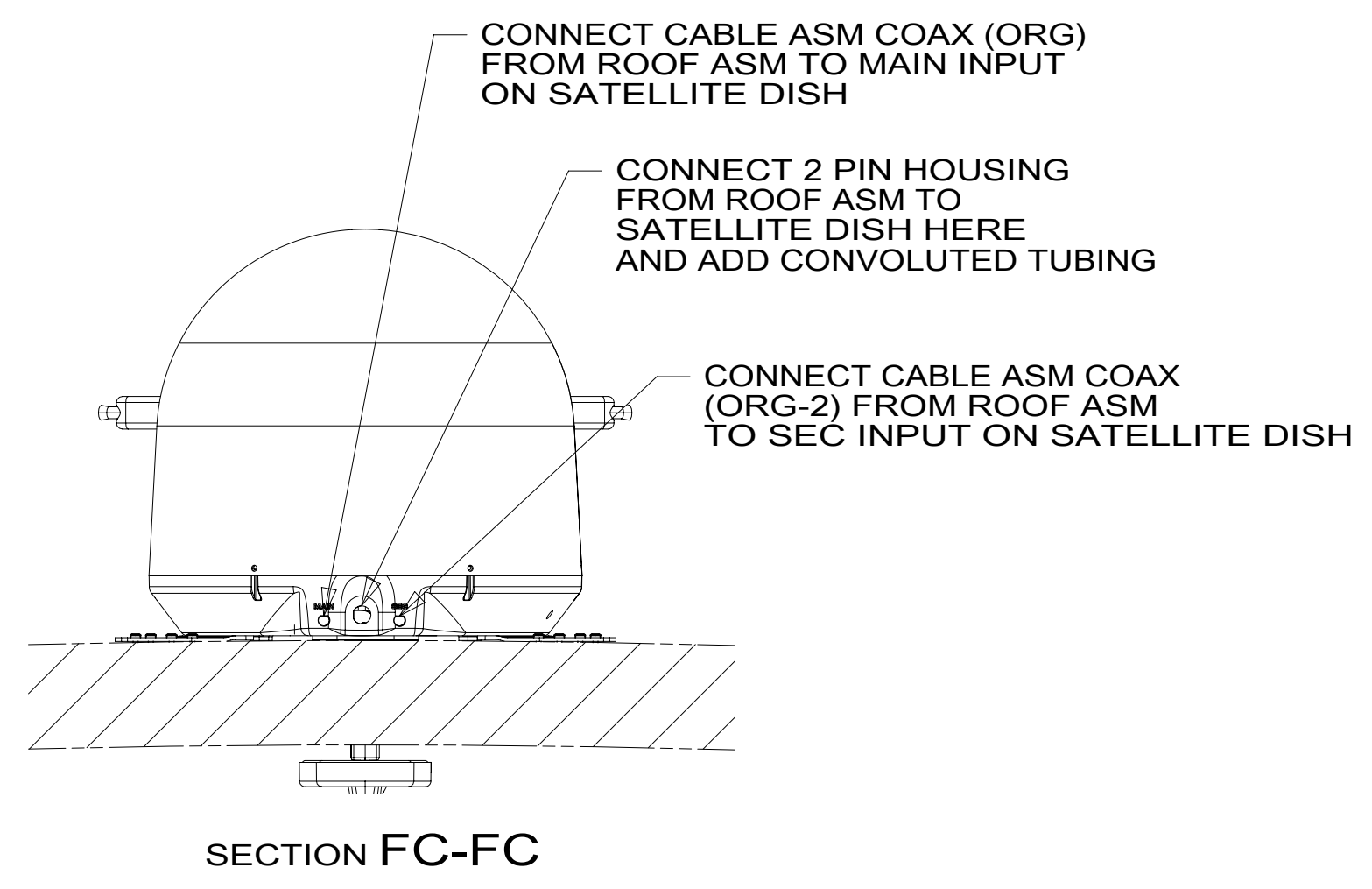
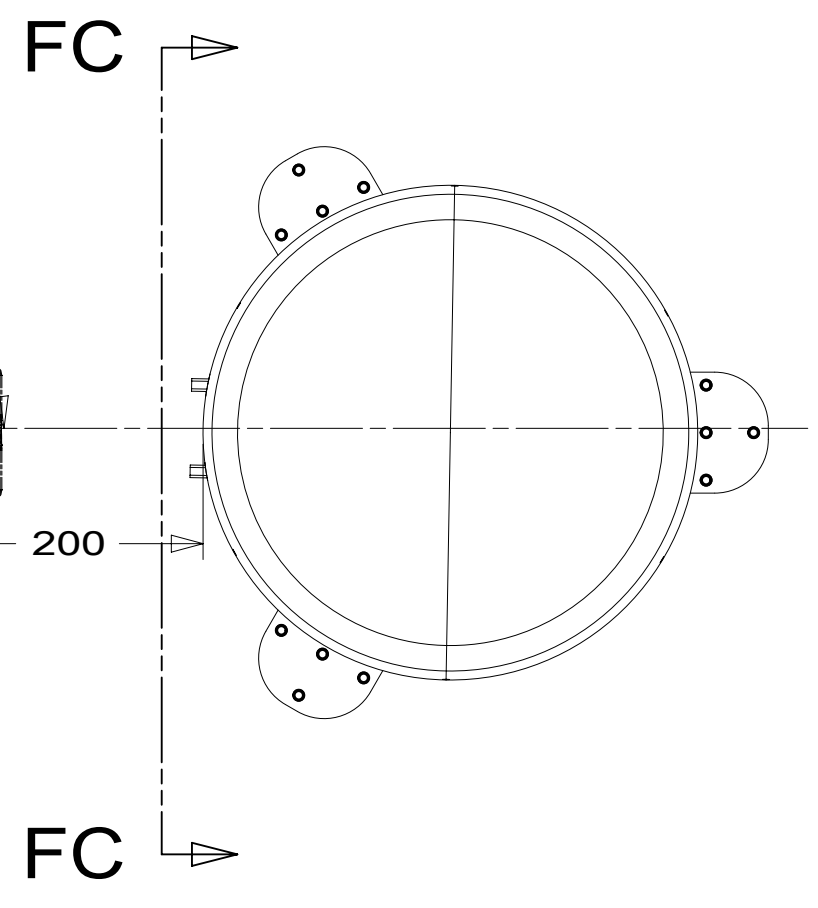

- ANTENNA-SATELLITE, STATIONARY
- 000017113 / 313336-01-CHT
- SCREW
- 000G39-08-08U (9)
- COAX CABLE
- 163598-04-000 (2)
- ADAPTER
- 082134-01-000 (2)
- CONDUIT
- 041953-06-000 (200 MM)
- SCREW
- 000G67-10-12U (10)
- (FOR PLATE SUPPLIED W/ DISH)
- DETAIL FB

78K

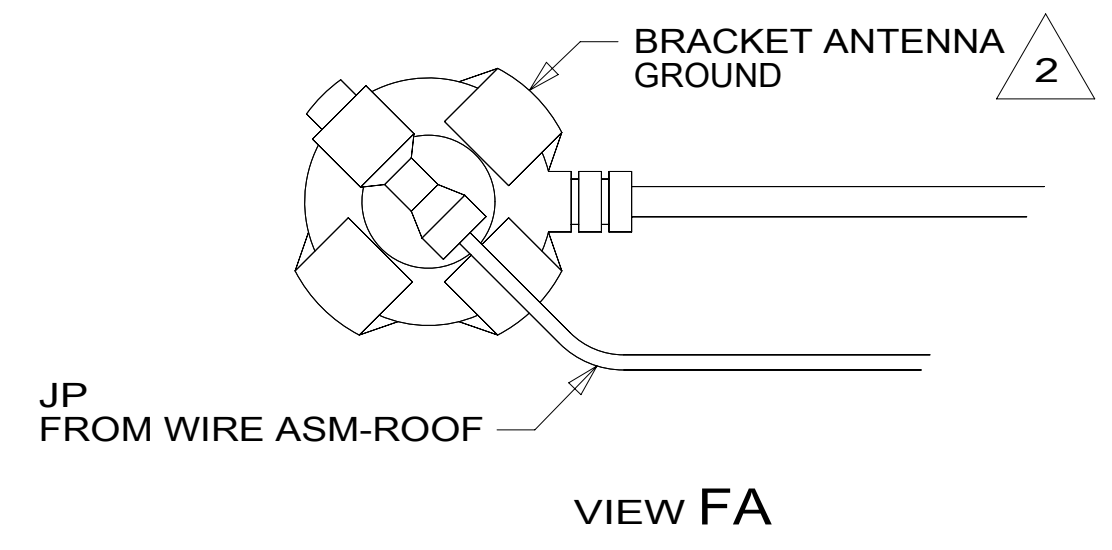
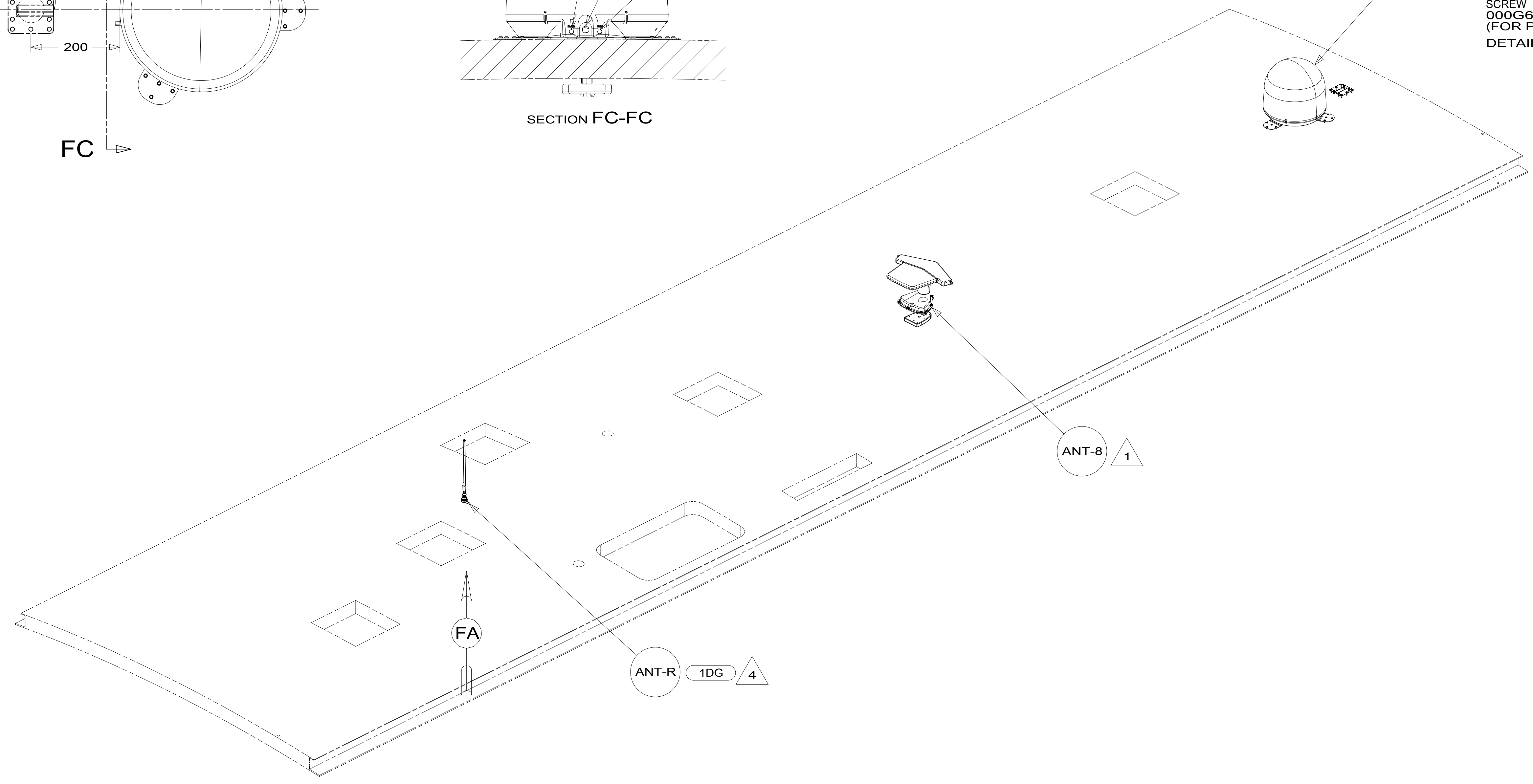

- NOTES:
- 4 REMOVE GROUND WIRE FROM ANTENNA BASE.
 - 3 SEE MANUFACTURER'S INSTALLATION FOR ADDITIONAL INFORMATION.
 - 2 WRAP LEGS AROUND ANTENNA BASE.
 - 1 SEE ANTENNA INSTALLATION MANUAL FOR CORRECT INSTALLATION PROCEDURE.

- 78K SATELLITE TV SYSTEM AUTO
- 1DG EXT ENTERTAIN CTR W/TV & CD
- 265 CODES/STANDARDS-CSA/CMVSS
- 1B1 CODES/STANDARDS USA

FOR ELECTRICAL TORQUE SPECIFICATIONS SEE DWG NO. 128783-01-000

FOR ELECTRICAL CALLOUTS SEE DWG NO. 121339-01-000

DESCRIPTION: WIRING INSTL-BODY, 12V		
SHEET: 6 OF 7	ITEM/PART NO.: 000179485 / 30036501000	REV

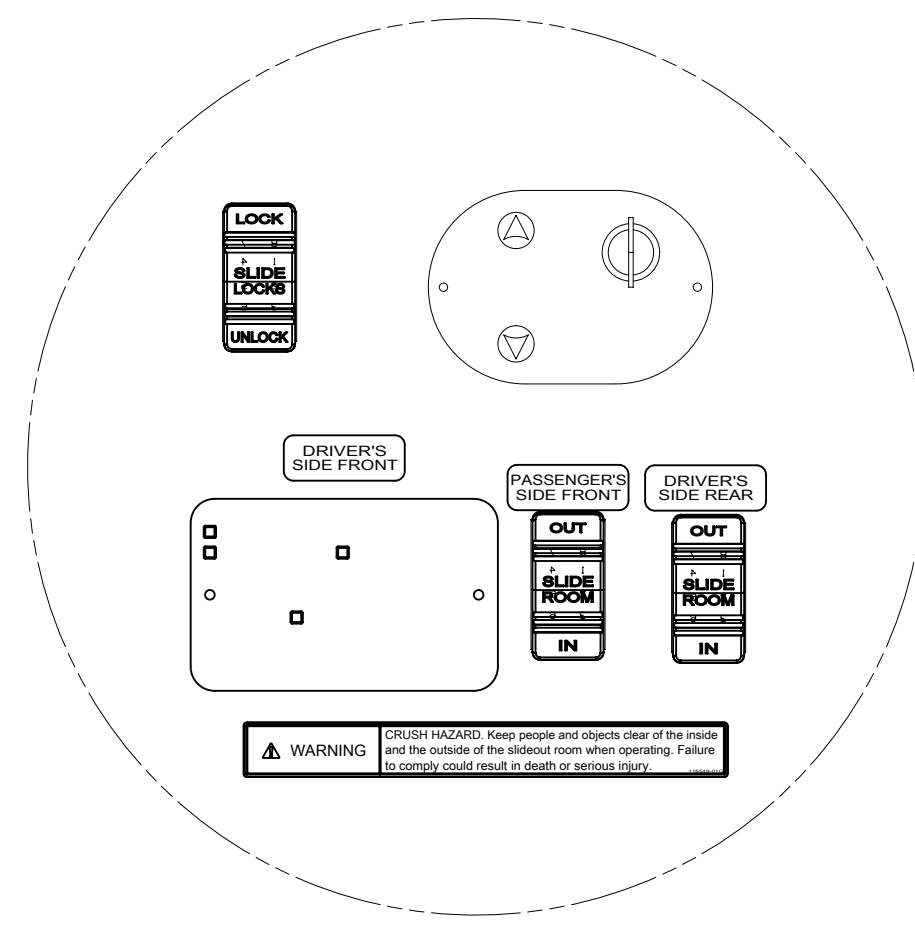

DETAIL DN

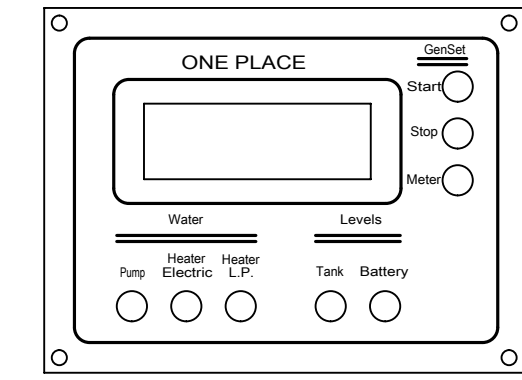

PANEL-MONITOR
175724-01-000
SCREW
G11-08-08U (4)

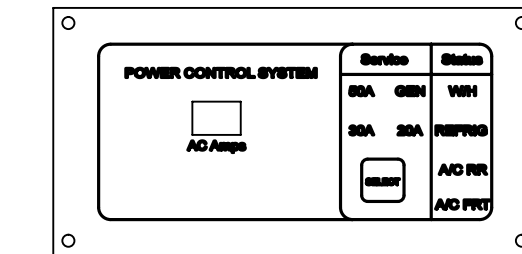

PANEL-MONITOR,EMS
174295-06-000

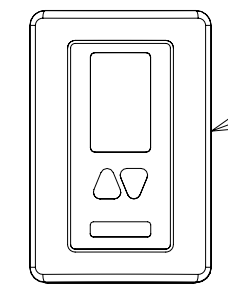

THERMOSTAT
000016270 / 313193-01-CHT
PLATE-SPACER,THERMOSTAT
000018276 / 313583-01-CHT
SCREW
G11-06-08U (2)

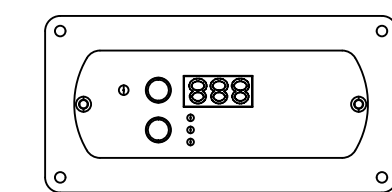

REMOTE PANEL-INVERTER
(SUPPLIED WITH INVERTER)
MODULE 12V-DISCONNECT
173355-01-000
DETAIL GB

DETAIL GA

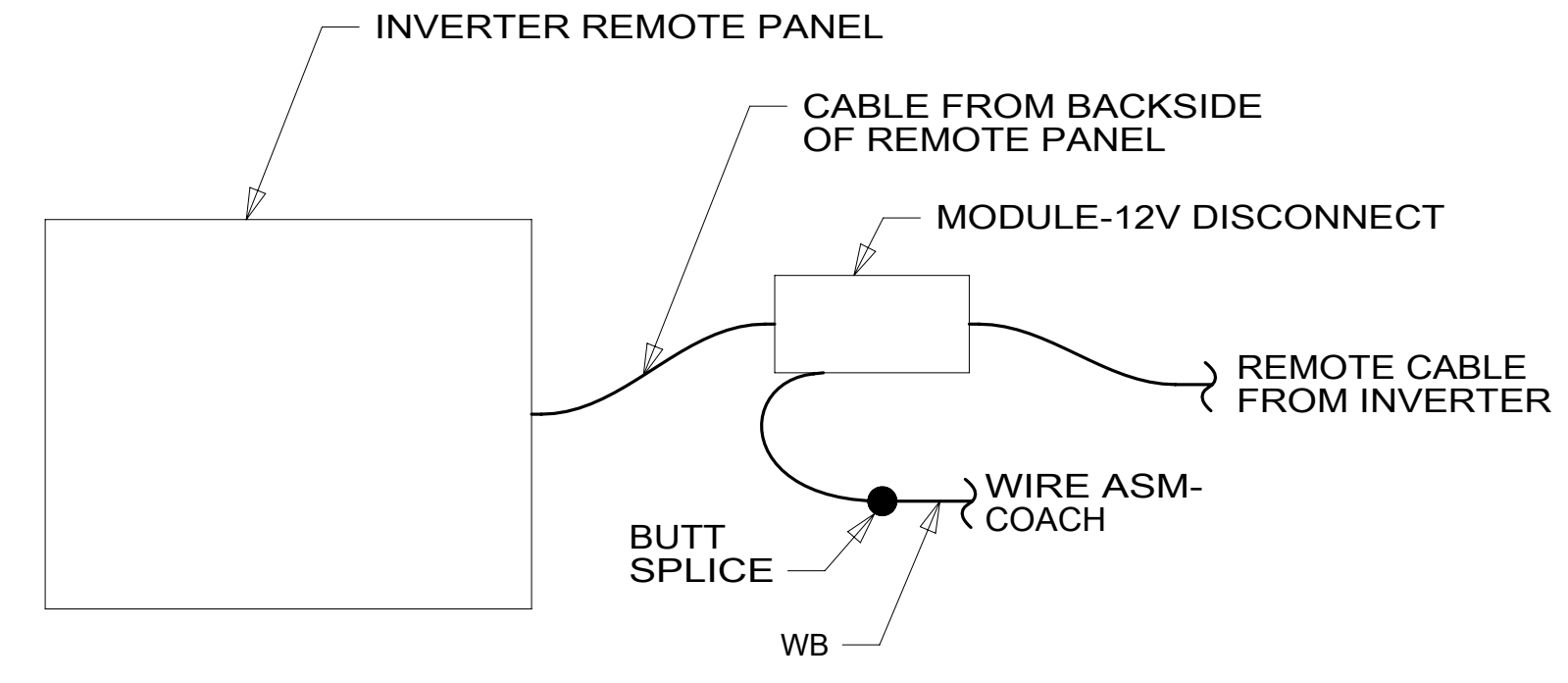

DETAIL GB

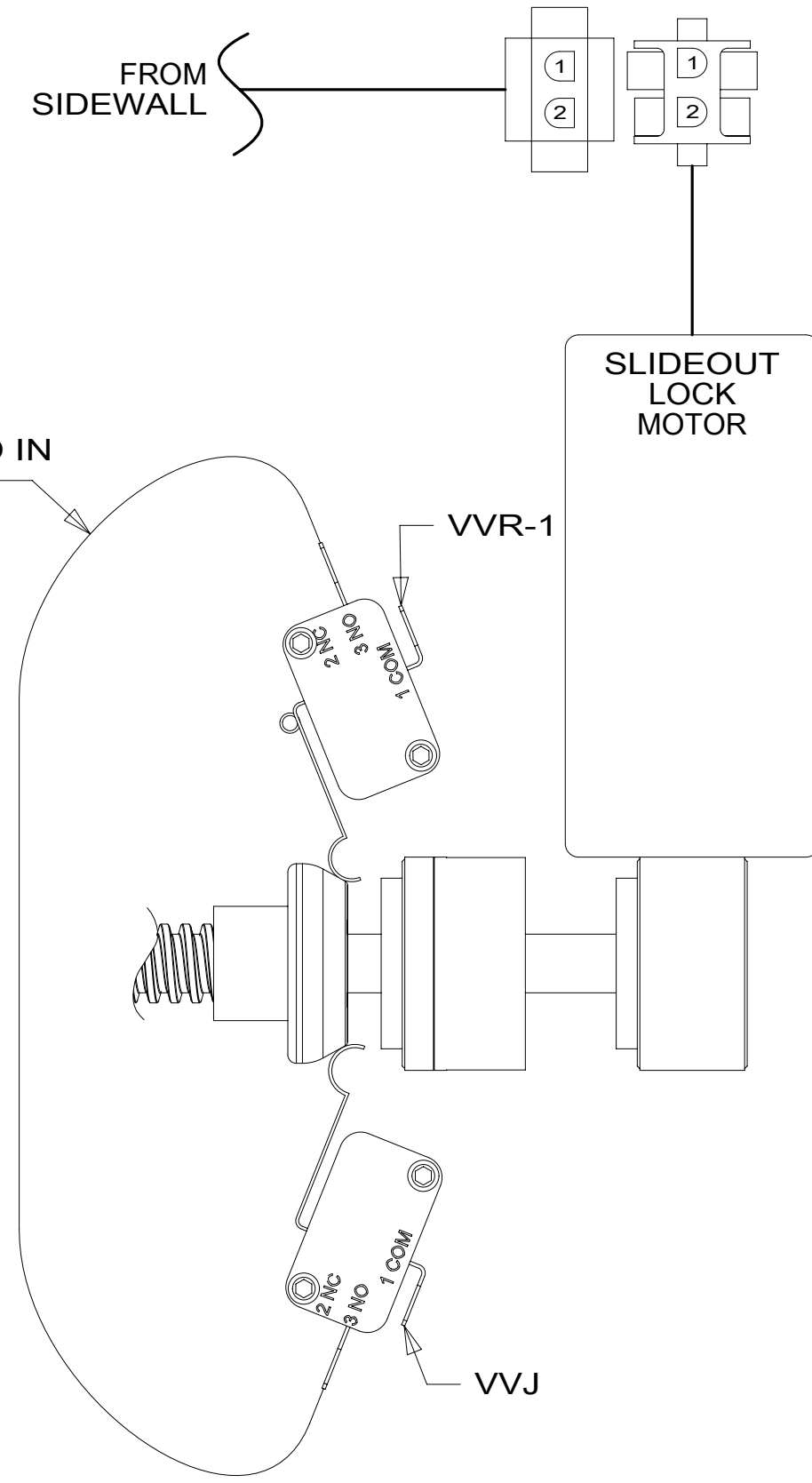

DETAIL GC
(FRONT LEFT)

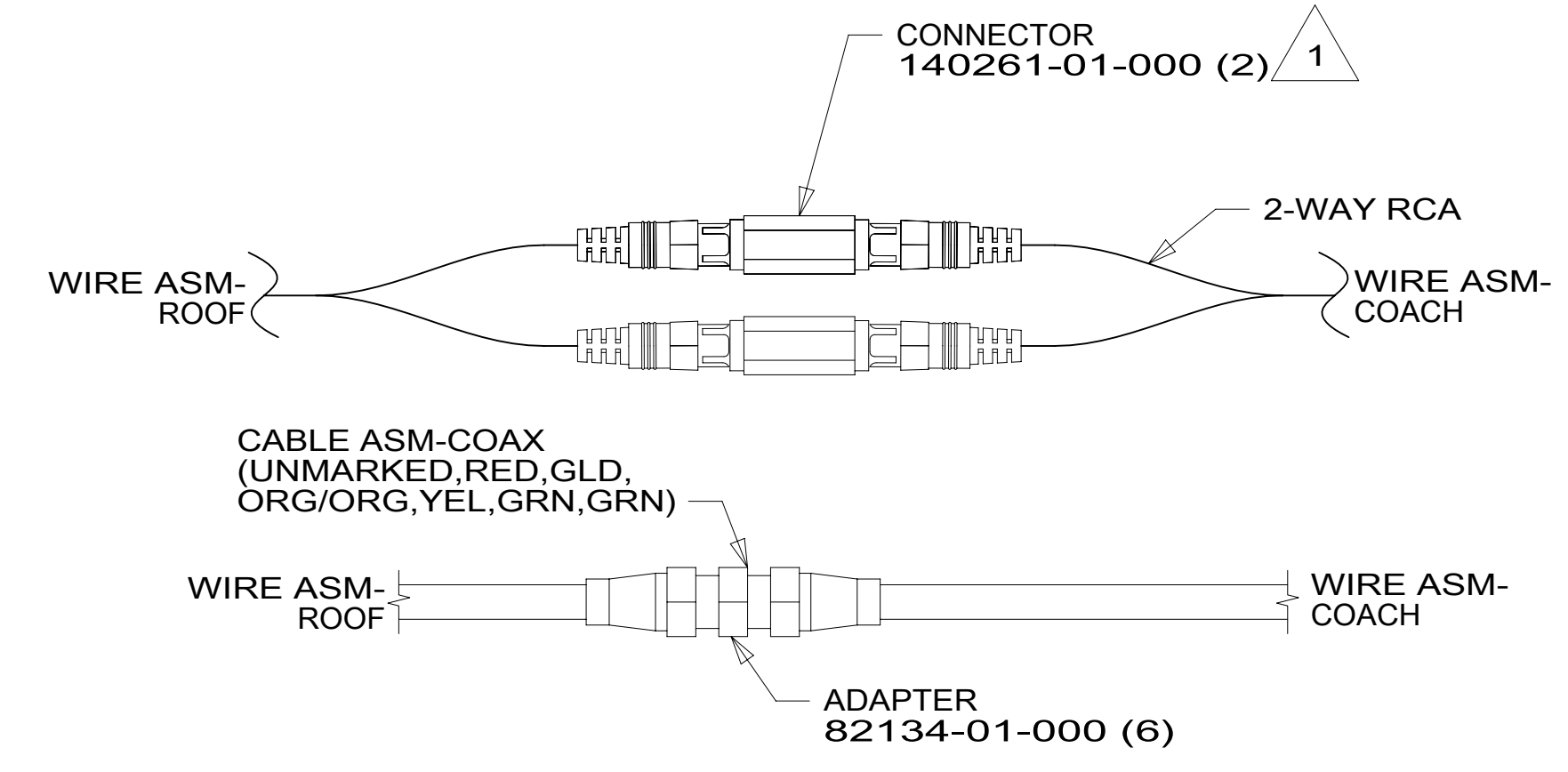
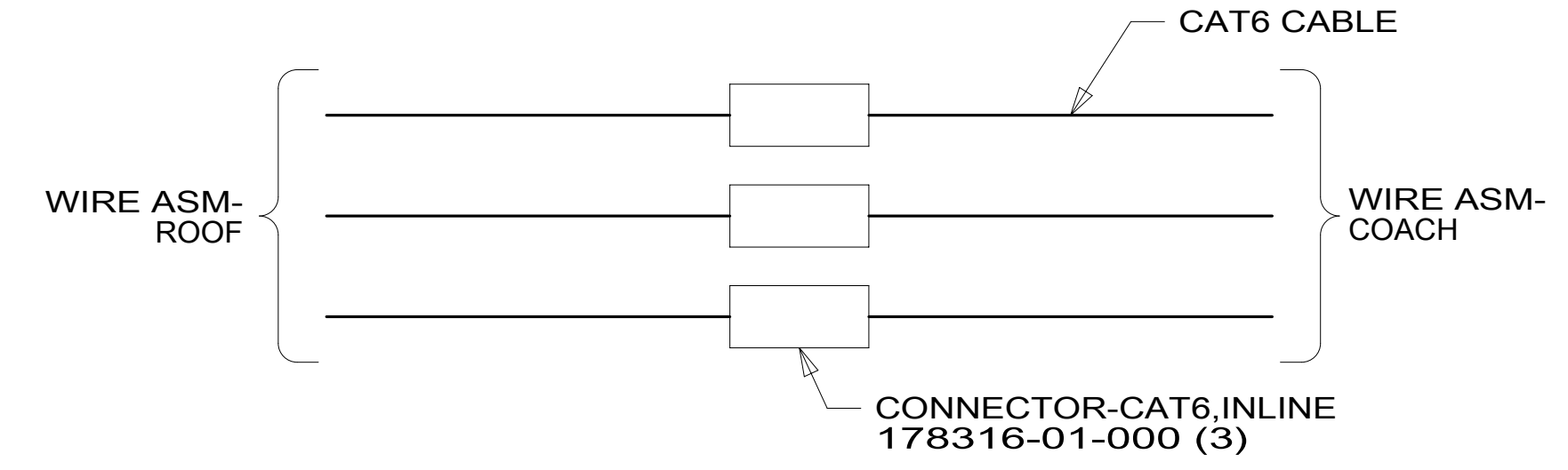

DETAIL GD

1 WRAP BOTH ENDS WITH TAPE 8363-01-000 TO SECURE CONNECTION.

NOTES:

FOR ELECTRICAL TORQUE SPECIFICATIONS SEE DWG NO. 128783-01-000

FOR ELECTRICAL CALLOUTS SEE DWG NO. 121339-01-000

- 401 INVERTER-DC/AC, 1000 WATT
- 265 CODES/STANDARDS-CSA/CMVSS
- 1B1 CODES/STANDARDS USA

DESCRIPTION:		1B1 265	
WIRING INSTL-BODY, 12V			
SHEET:	ITEM/PART NO.:	REV	
7 OF 7	000179485 / 30036501000		