

8 7 6 5 4 3 2 1

D
C
B
A

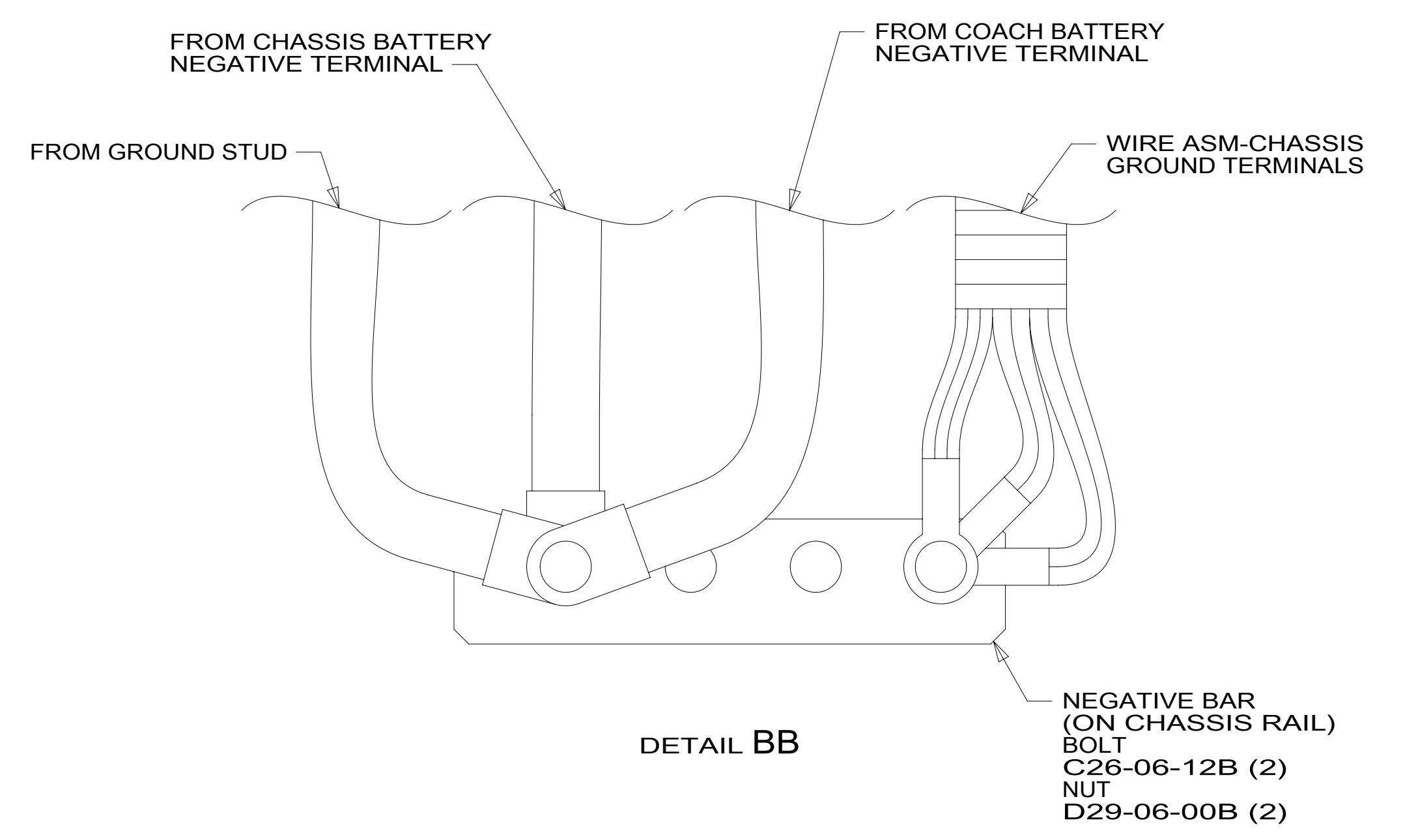
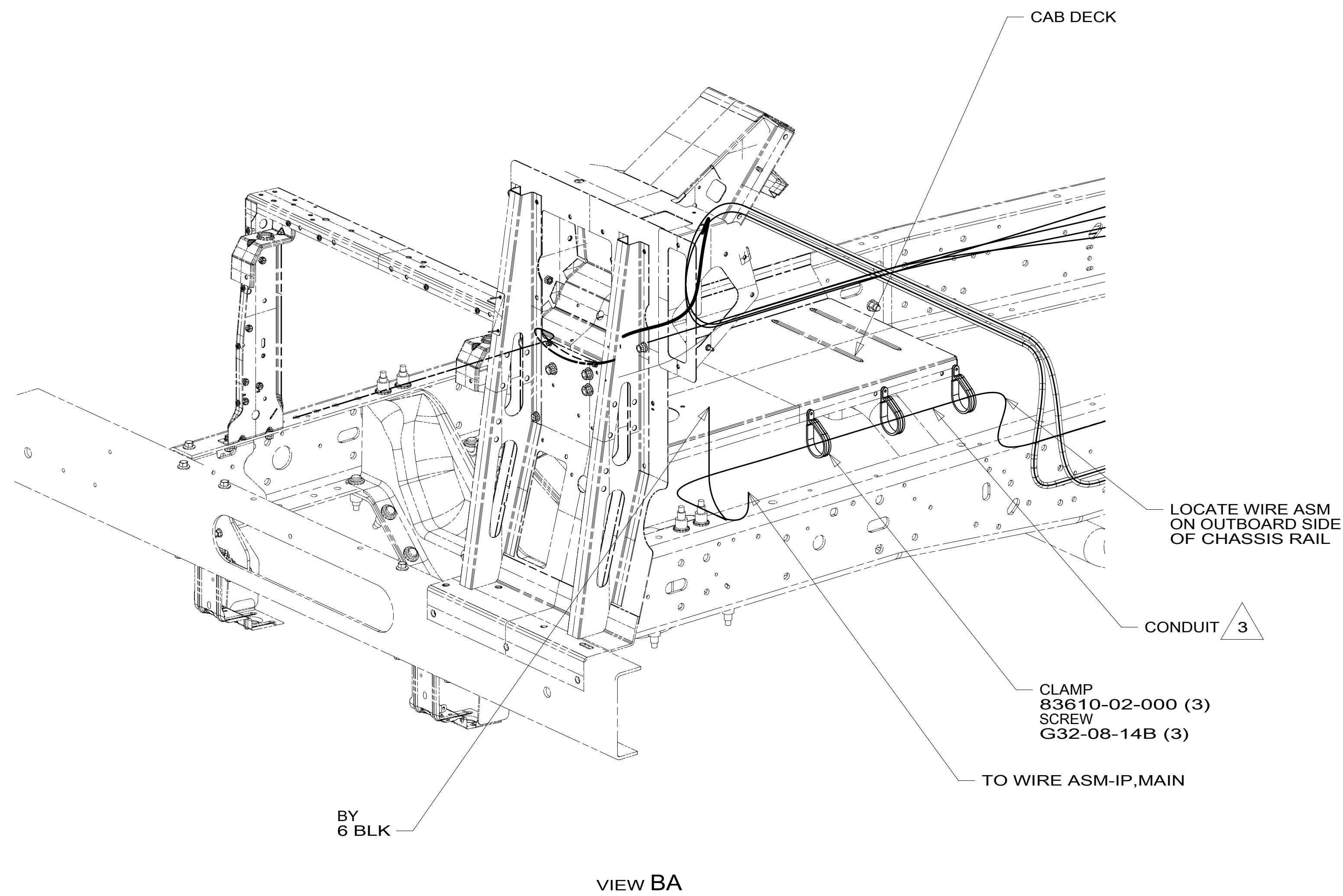

3 COVER WITH CONDUIT 41953-10-000 AND 41953-11-000 AS REQUIRED.

- 2. CONNECT CABLES TO COACH SIDE OF BATTERY DISCONNECT WHEN BATTERY DISCONNECT IS USED.
- 1. CUT OFF EXCESS END OF WIRE TIE.

NOTES:

FOR ELECTRICAL TORQUE SPECIFICATIONS SEE DWG NO. 128783-01-000

FOR ELECTRICAL CALLOUTS SEE DWG NO. 121339-01-000

265 CODES/STANDARDS-CSA/CMVSS
1B1 CODES/STANDARDS USA

DESCRIPTION:		1B1 265
WIRING INSTL-CHASSIS		
SHEET:	ITEM/PART NO.:	REV
2 OF 2	000179415 / 30014001000	

8 7 6 5 4 3 2 1 20-Sep-2016