

- NOTES:
- 1. AT MINIMUM ALL WIRES TO BE SUPPORTED AND SECURED PER CODE REQUIREMENTS. USE CLAMP 10495 OR 10497 OR WIRE TIE 8343 OR 108046 AND SCREW G67-XX-XXX OR G56-XX-XXX AS APPROPRIATE FOR INSTALLATION.
 - 2. ROUTE TANK SENSOR WIRES SO THEY DO NOT PASS OVER SENSORS. USE WIRE TIE MOUNT 155366-01-000 AND WIRE TIE 8343-01-000 AS NEEDED. TANK SURFACE MUST BE CLEANED USING ISOPROPYL ALCOHOL AND PRIMED WITH PRIMER 94.
- 7 WIRING IS PART OF WIRE ASM-CHASSIS.
- 6 WITH 1D3 ROUTE YELLOW COAX TO SLIDEOUT WITH WIRE ASM-COACH.
- 5 NOT USED WITH 1D3
- 4 WIRE PASSES THROUGH FLOOR IN THIS AREA.
- 3 PLACE CROSS LOCATOR ON SENSORS OVER DIMPLES ON TANK.

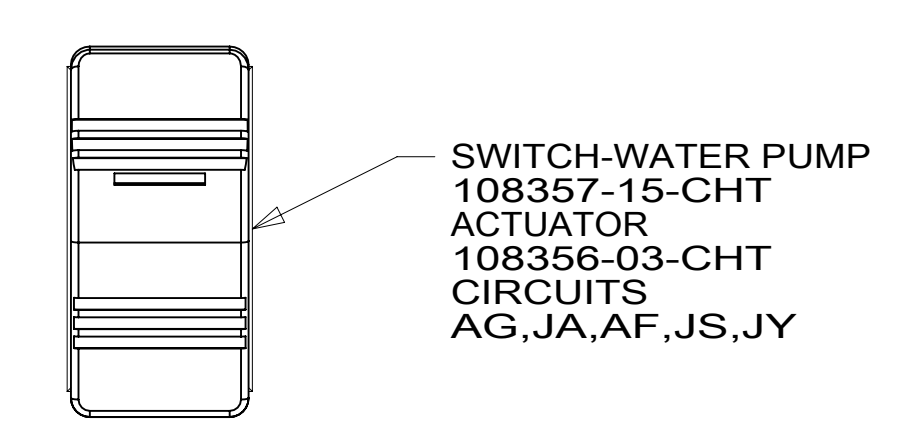
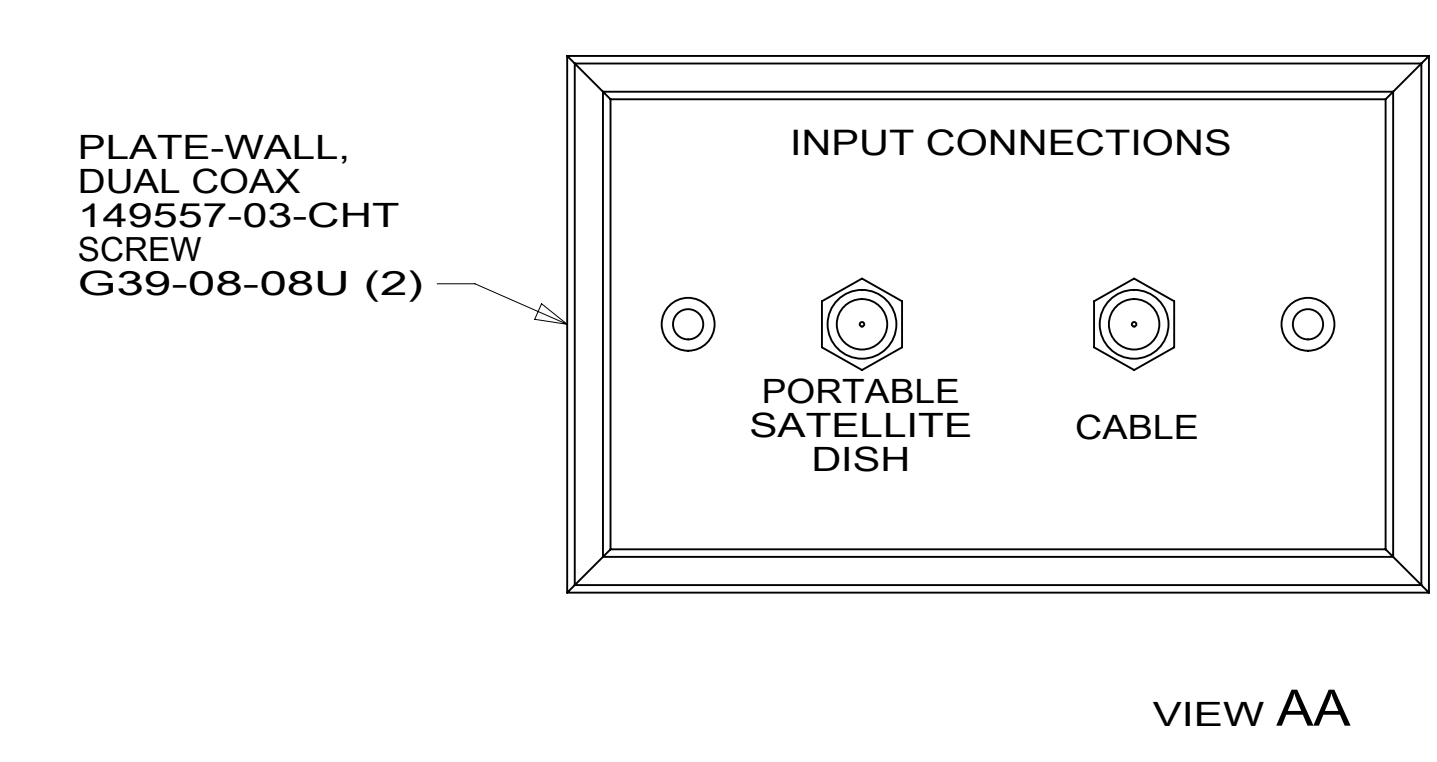

FOR ELECTRICAL TORQUE SPECIFICATIONS SEE DWG NO. 128783-01-000

FOR ELECTRICAL CALLOUTS SEE DWG NO. 121339-01-000

1D3 ENTERTAIN CENTR/EXT TV-DVD

265 CODES/STANDARDS-CSA/CMVSS

1B1 CODES/STANDARDS USA

1B1 265

COPYRIGHT 2016 WINNEBAGO INDUSTRIES, INC.

DSNR:		ALL DIMENSIONS ARE IN MILLIMETERS	
DIFFR:			
UNSPECIFIED TOLERANCES:		MATERIAL:	
WHOLE DIM (X)	: 3		
ONE-PLACE (X.X)	: 1.5		
TWO-PLACE (X.XX)	: 0.50		
ANGLE	: 1°		
REFER TO ES0018 FOR FASTENER TIGHTENING GUIDELINES		WEIGHT: (LBS)	FIRST USED:
			16 E27N
DESCRIPTION: WIRING INSTL-BODY, 12V			
SHEET: 1 OF 7	ITEM/PART NO: 000177076 / 30044901000	REV	

REF: 1 20-Sep-2016

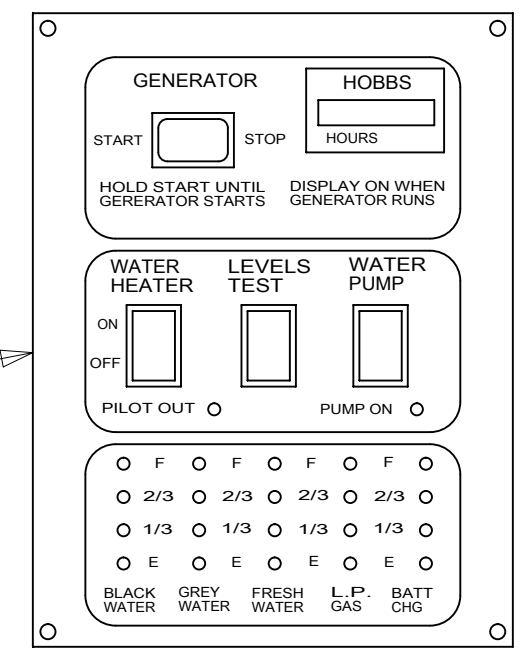
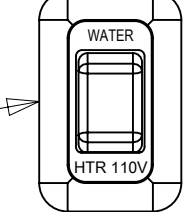
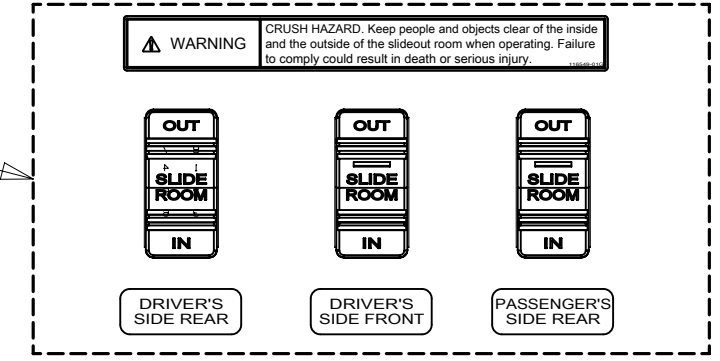
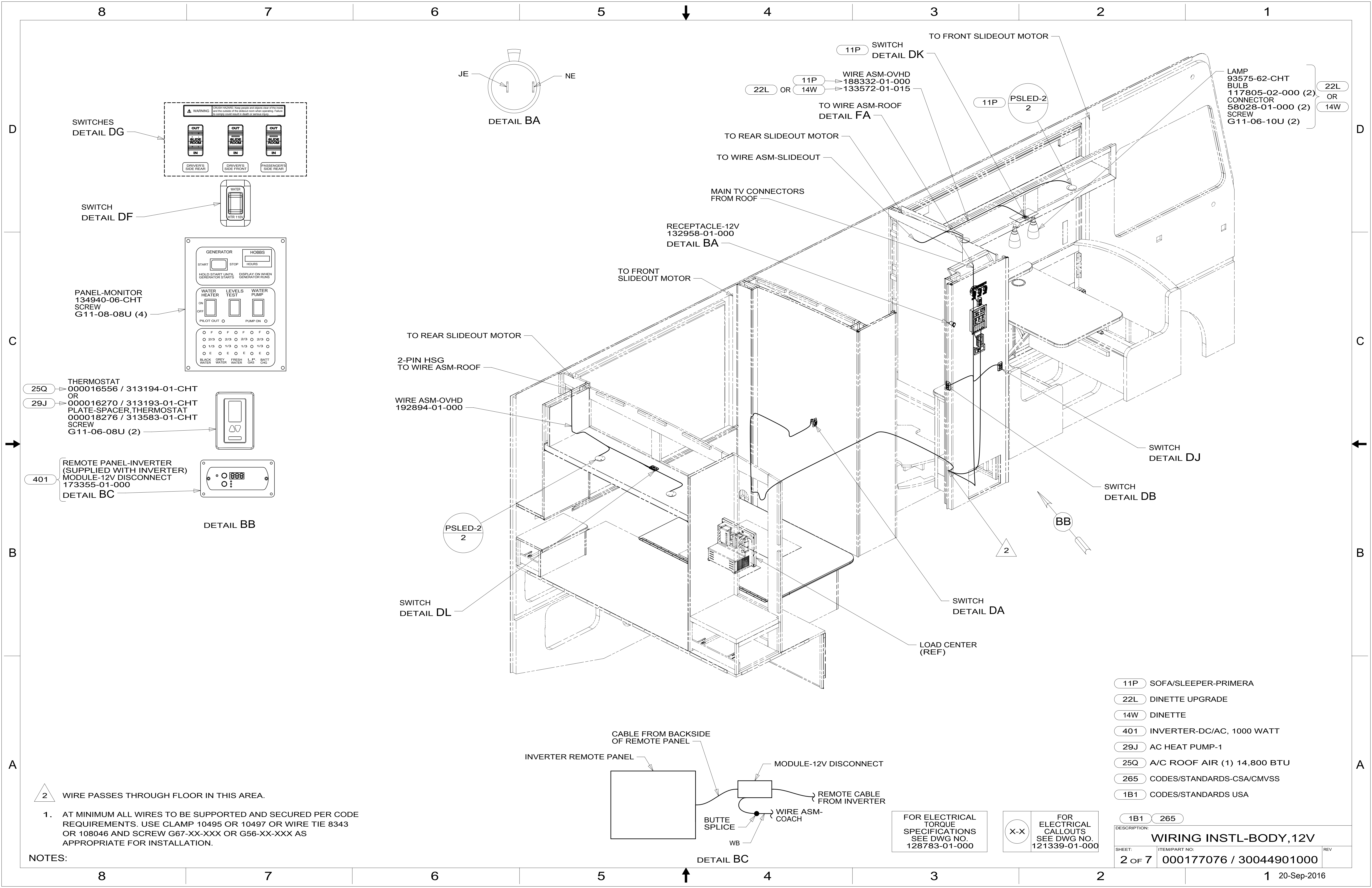

25Q → THERMOSTAT
000016556 / 313194-01-CHT
OR
29J → 000016270 / 313193-01-CHT
000018276 / 313583-01-CHT
SCREW
G11-06-08U (2)

401 → REMOTE PANEL-INVERTER
(SUPPLIED WITH INVERTER)
MODULE-12V DISCONNECT
173355-01-000
DETAIL BC

DETAIL BB

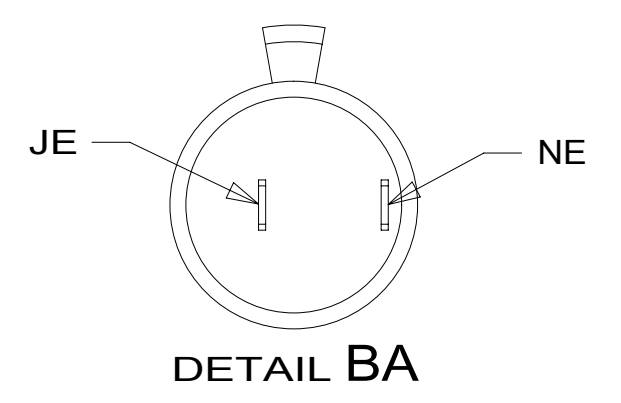

11P SWITCH
DETAIL DK
TO FRONT SLIDEOUT MOTOR
WIRE ASM-OVHD
188332-01-000
22L OR 14W → 133572-01-015
11P PSLED-2
2
LAMP
93575-62-CHT
BULB
117805-02-000 (2)
CONNECTOR
58028-01-000 (2)
SCREW
G11-06-10U (2)
22L OR 14W

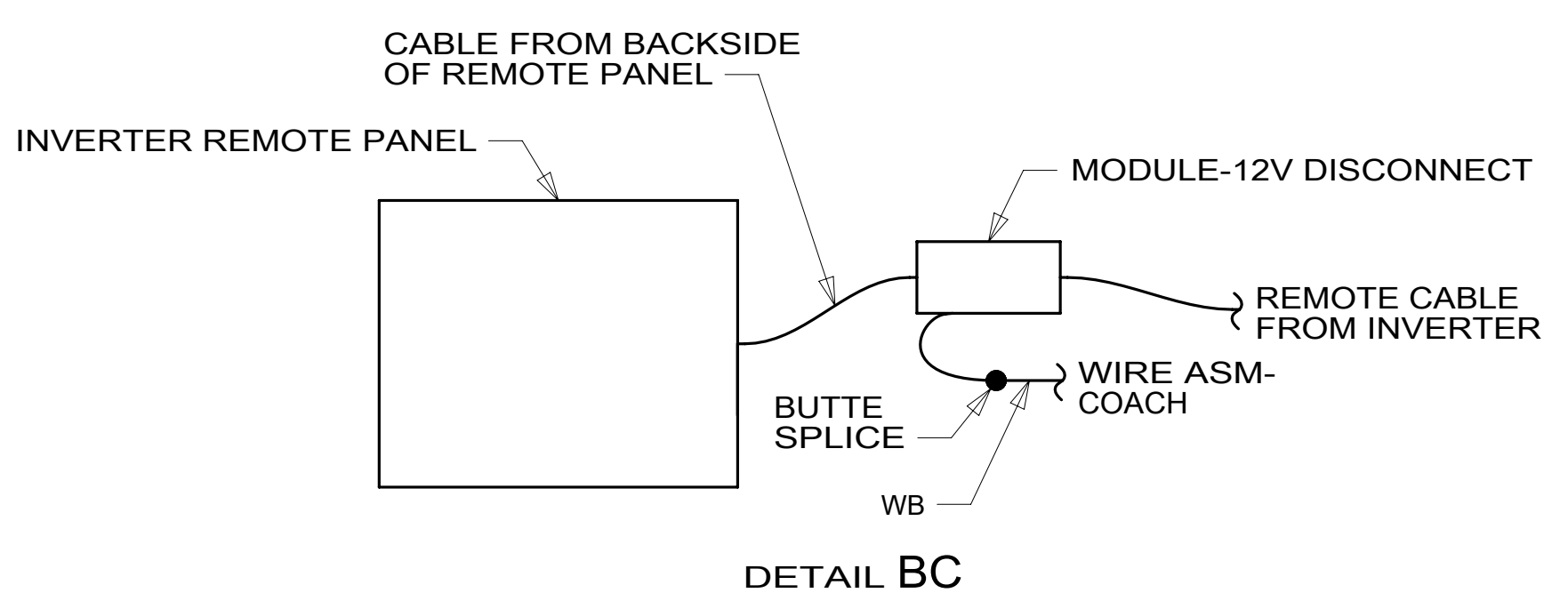
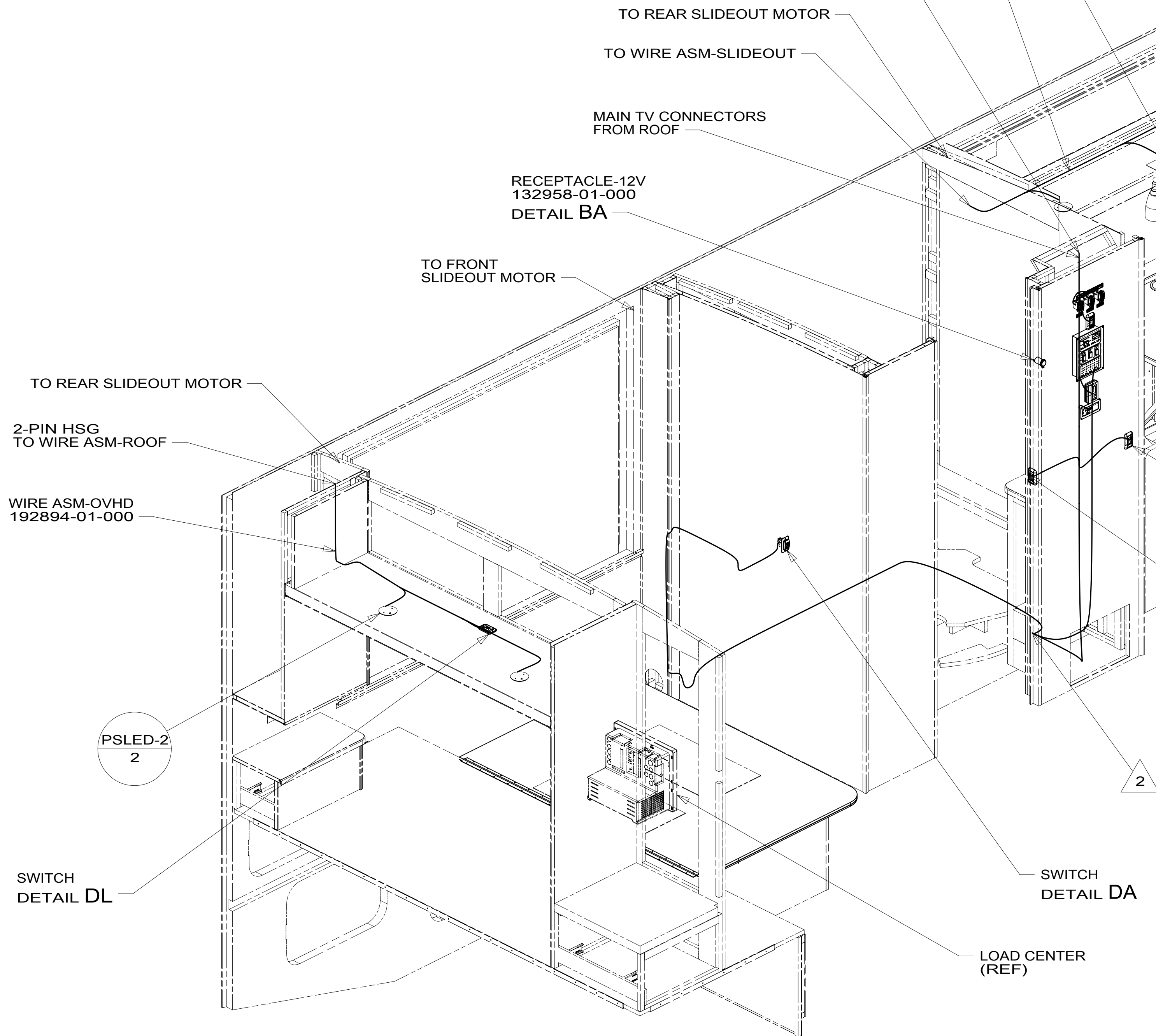

- 11P SOFA/SLEEPER-PRIMERA
- 22L DINETTE UPGRADE
- 14W DINETTE
- 401 INVERTER-DC/AC, 1000 WATT
- 29J AC HEAT PUMP-1
- 25Q A/C ROOF AIR (1) 14,800 BTU
- 265 CODES/STANDARDS-CSA/CMVSS
- 1B1 CODES/STANDARDS USA

2 WIRE PASSES THROUGH FLOOR IN THIS AREA.

1. AT MINIMUM ALL WIRES TO BE SUPPORTED AND SECURED PER CODE REQUIREMENTS. USE CLAMP 10495 OR 10497 OR WIRE TIE 8343 OR 108046 AND SCREW G67-XX-XXX OR G56-XX-XXX AS APPROPRIATE FOR INSTALLATION.

FOR ELECTRICAL TORQUE SPECIFICATIONS SEE DWG NO. 128783-01-000

FOR ELECTRICAL CALLOUTS SEE DWG NO. 121339-01-000

DESCRIPTION:		1B1 265	
WIRING INSTL-BODY, 12V			
SHEET:	ITEM/PART NO.:	REV:	
2 OF 7	000177076 / 30044901000		

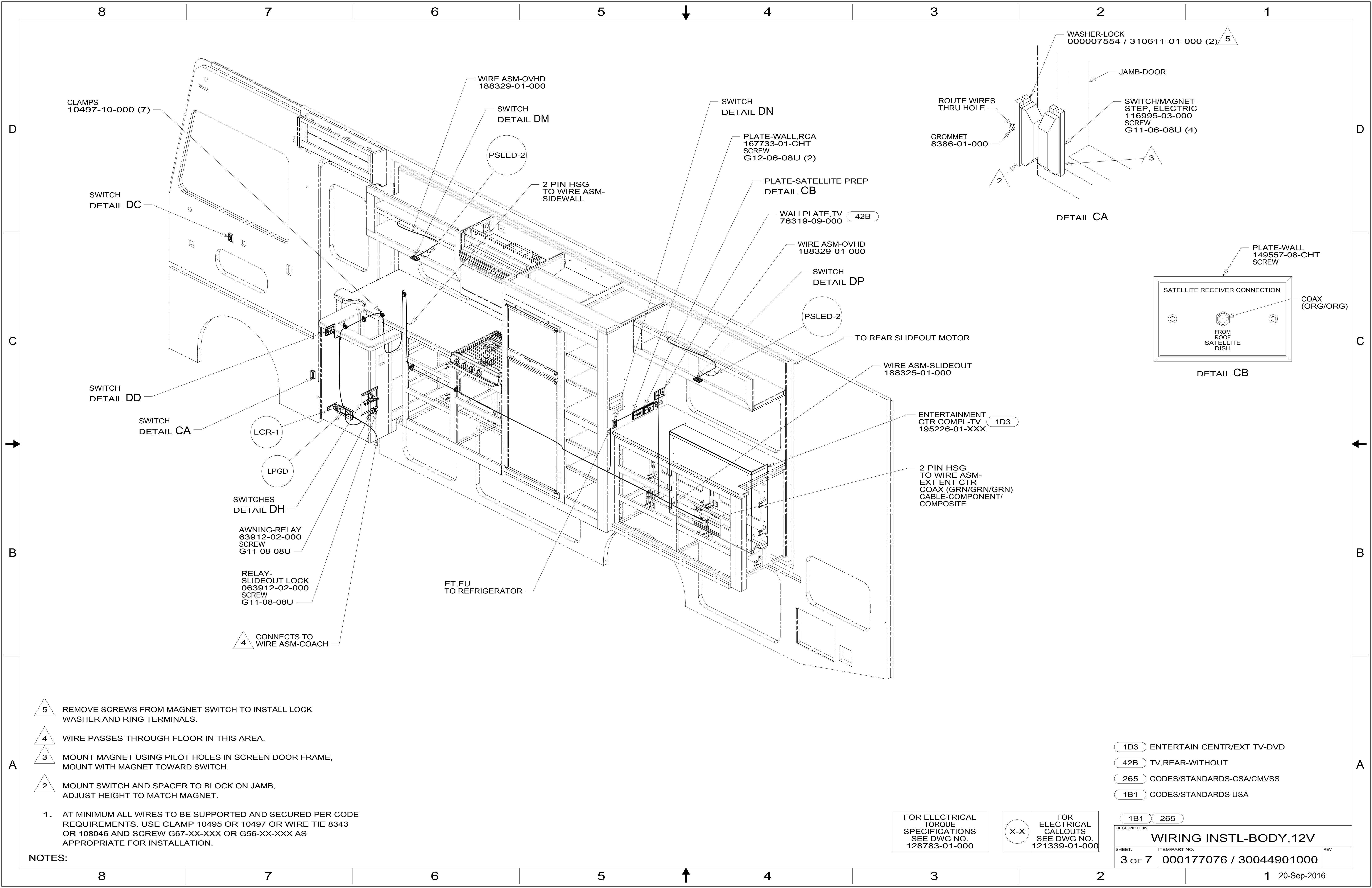

CLAMPS
10497-10-000 (7)

SWITCH
DETAIL DC

SWITCH
DETAIL DD

SWITCH
DETAIL CA

LCR-1

LPGD

SWITCHES
DETAIL DH

AWNING-RELAY
63912-02-000
SCREW
G11-08-08U

RELAY-
SLIDEOUT LOCK
063912-02-000
SCREW
G11-08-08U

4 CONNECTS TO
WIRE ASM-COACH

WIRE ASM-OVHD
188329-01-000

SWITCH
DETAIL DM

PSLED-2

2 PIN HSG
TO WIRE ASM-
SIDEWALL

ET,EU
TO REFRIGERATOR

SWITCH
DETAIL DN

PLATE-WALL,RCA
167733-01-CHT
SCREW
G12-06-08U (2)

PLATE-SATELLITE PREP
DETAIL CB

WALLPLATE,TV
76319-09-000 42B

WIRE ASM-OVHD
188329-01-000

SWITCH
DETAIL DP

PSLED-2

TO REAR SLIDEOUT MOTOR

WIRE ASM-SLIDEOUT
188325-01-000

ENTERTAINMENT
CTR COMPL-TV
195226-01-XXX 1D3

2 PIN HSG
TO WIRE ASM-
EXT ENT CTR
COAX (GRN/GRN/GRN)
CABLE-COMPONENT/
COMPOSITE

ROUTE WIRES
THRU HOLE

GROMMET
8386-01-000

WASHER-LOCK
00007554 / 310611-01-000 (2) 5

JAMB-DOOR

SWITCH/MAGNET-
STEP, ELECTRIC
116995-03-000
SCREW
G11-06-08U (4)

DETAIL CA

PLATE-WALL
149557-08-CHT
SCREW

SATELLITE RECEIVER CONNECTION

COAX
(ORG/ORG)

FROM ROOF
SATELLITE
DISH

DETAIL CB

5 REMOVE SCREWS FROM MAGNET SWITCH TO INSTALL LOCK WASHER AND RING TERMINALS.

4 WIRE PASSES THROUGH FLOOR IN THIS AREA.

3 MOUNT MAGNET USING PILOT HOLES IN SCREEN DOOR FRAME, MOUNT WITH MAGNET TOWARD SWITCH.

2 MOUNT SWITCH AND SPACER TO BLOCK ON JAMB, ADJUST HEIGHT TO MATCH MAGNET.

1. AT MINIMUM ALL WIRES TO BE SUPPORTED AND SECURED PER CODE REQUIREMENTS. USE CLAMP 10495 OR 10497 OR WIRE TIE 8343 OR 108046 AND SCREW G67-XX-XXX OR G56-XX-XXX AS APPROPRIATE FOR INSTALLATION.

NOTES:

FOR ELECTRICAL
TORQUE
SPECIFICATIONS
SEE DWG NO.
128783-01-000

FOR
ELECTRICAL
CALLOUTS
SEE DWG NO.
121339-01-000

1D3 ENTERTAIN CENTR/EXT TV-DVD

42B TV,REAR-WITHOUT

265 CODES/STANDARDS-CSA/CMVSS

1B1 CODES/STANDARDS USA

1B1 265

DESCRIPTION:
WIRING INSTL-BODY, 12V

SHEET: 3 OF 7 ITEM/PART NO: 000177076 / 30044901000 REV

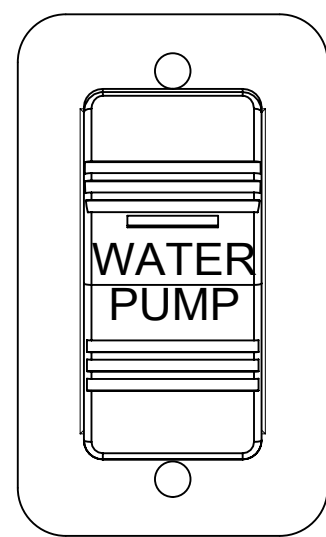

SWITCH-PUMP
108357-15-000
ACTUATOR
108356-23-CHT
PLATE
98351-07-CHT
SCREW
G11-06-10U (2)

DETAIL DA
(2 PLACES)

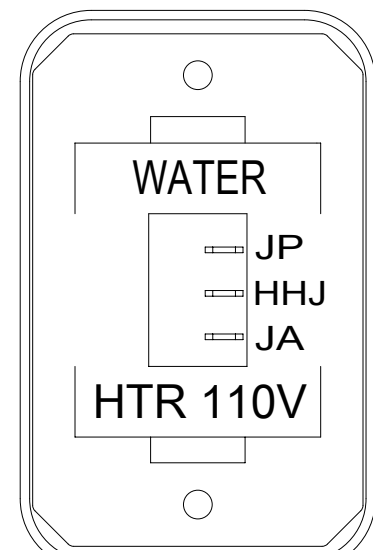

SWITCH-ROCKER
135740-06-CHT
SWITCH-BASE
135741-01-CHT
SWITCH-BEZEL
135742-35-CHT
SCREW
G11-08-08U (2)

DETAIL DF

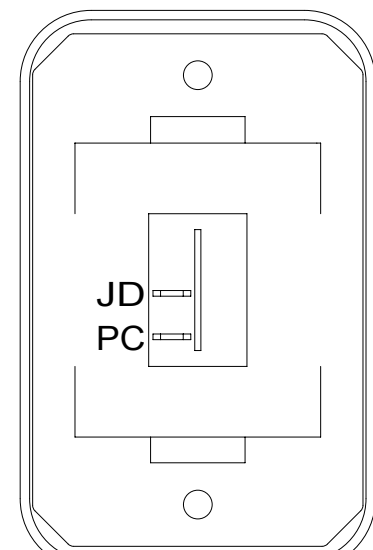

SWITCH-ROCKER
135740-01-CHT
SWITCH-BASE
135741-01-CHT
SWITCH-BEZEL
135742-01-CHT
SCREW
G11-08-08U (2)

DETAIL DN

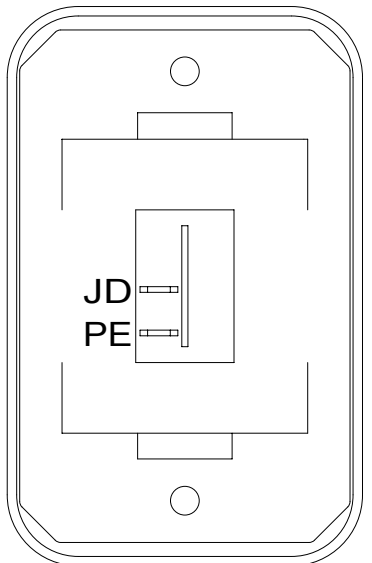

SWITCH-ROCKER
135740-01-CHT
SWITCH-BASE
135741-01-CHT
SWITCH-BEZEL
135742-01-CHT
SCREW
G11-08-08U (2)

DETAIL DB

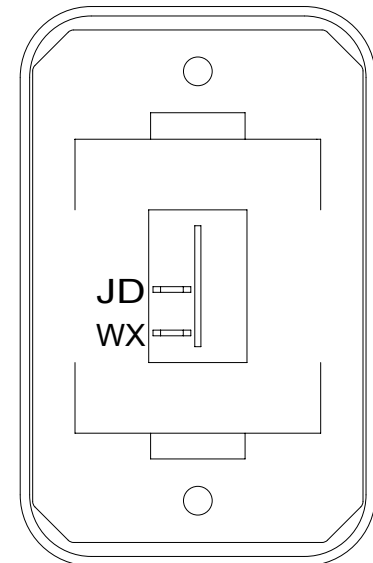

SWITCH-ROCKER
135740-01-CHT
SWITCH-BASE
135741-01-CHT
SWITCH-BEZEL
135742-01-CHT
SCREW
G11-08-08U (2)

DETAIL DJ

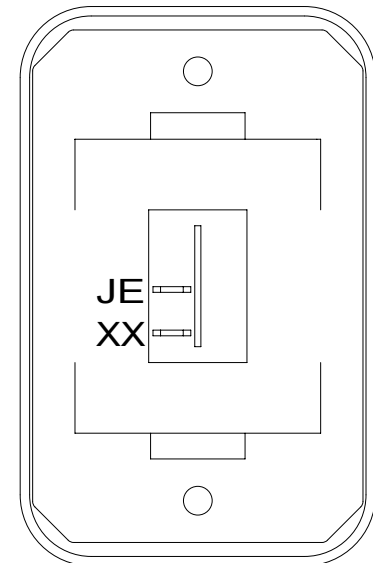

SWITCH-ROCKER
135740-01-CHT
SWITCH-BASE
135741-01-CHT
SWITCH-BEZEL
135742-01-CHT
SCREW
G11-08-08U (2)

DETAIL DP

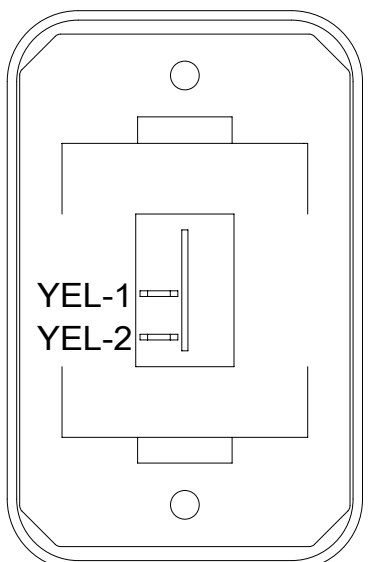

SWITCH-ROCKER
135740-01-CHT
SWITCH-BASE
135741-01-CHT
SWITCH-BEZEL
135742-01-CHT
SCREW
G11-08-08U (2)

DETAIL DC

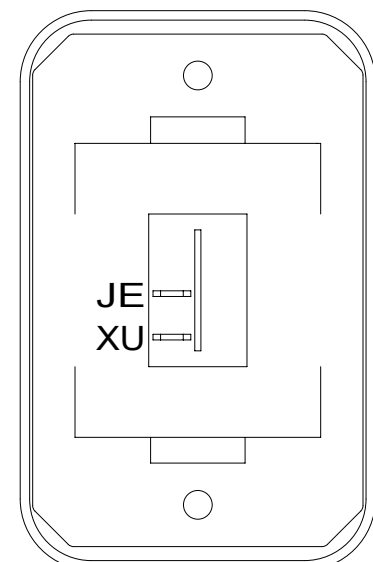

SWITCH-ROCKER
135740-01-CHT
SWITCH-BASE
135741-01-CHT
SWITCH-BEZEL
135742-01-CHT
SCREW
G11-08-08U (2)

DETAIL DK

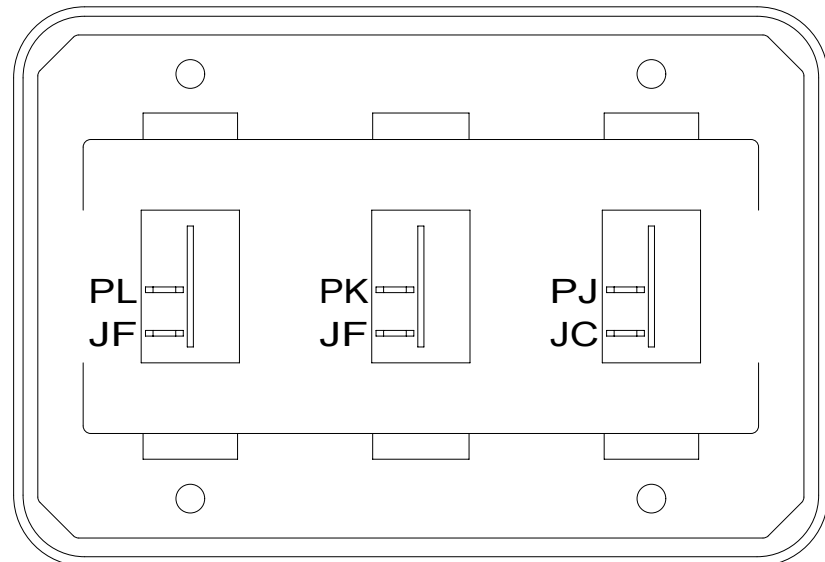

SWITCH-ROCKER
135740-01-CHT (3)
SWITCH-BASE
135741-03-CHT
SWITCH-BEZEL
135742-03-CHT
SCREW
G11-08-08U (4)

DETAIL DD

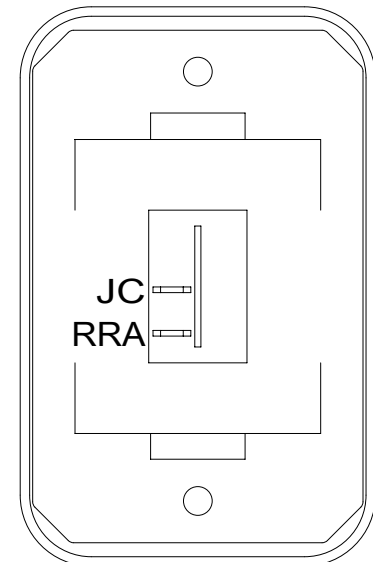

SWITCH-ROCKER
135740-01-CHT
SWITCH-BASE
135741-01-CHT
SWITCH-BEZEL
135742-01-CHT
SCREW
G11-08-08U (2)

DETAIL DL

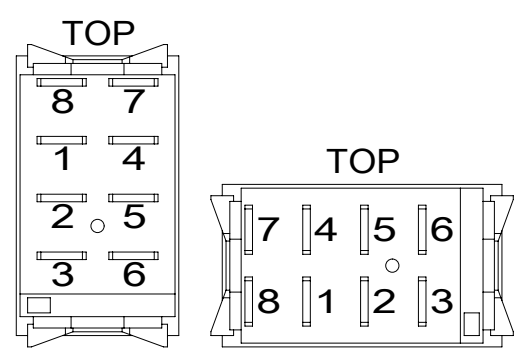

DETAIL DE

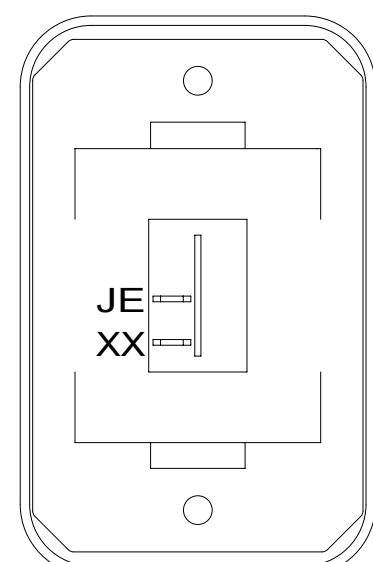

SWITCH-ROCKER
135740-01-CHT
SWITCH-BASE
135741-01-CHT
SWITCH-BEZEL
135742-01-CHT
SCREW
G11-08-08U (2)

DETAIL DM

LABEL-WARNING,SLIDEOUT
116549-01-000

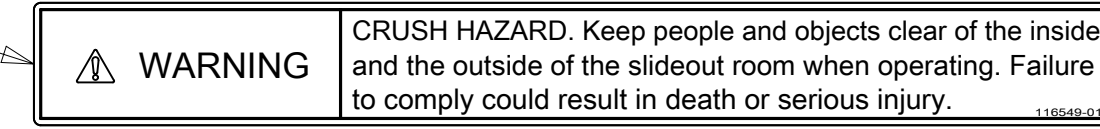

SWITCH-ROCKER
108357-07-000
ACTUATOR-SWITCH
108356-24-CHT
CIRCUITS
BBM,DT,BBN

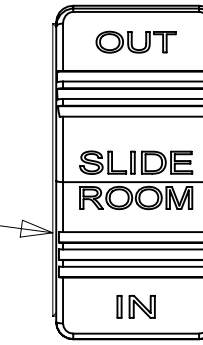

DRIVER'S
SIDE REAR

LABEL-SLIDEOUT,
DRIVER,REAR
163992-02-CHT

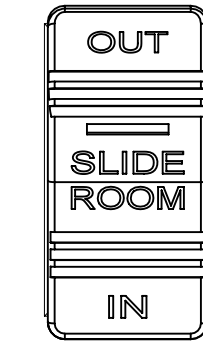

DRIVER'S
SIDE FRONT

LABEL-SLIDEOUT,
DRIVER,FRONT
163992-01-CHT



PASSENGER'S
SIDE REAR

SWITCH
108357-18-000
ACTUATOR
108356-31-CHT
CIRCUITS
DU,KE,DR,ABY,ABZ

SWITCH
108357-18-000
ACTUATOR
108356-31-CHT
CIRCUITS
HHH,KE,HHG,ACC,ACD

LABEL-SLIDEOUT
PASS,REAR
163992-03-CHT

DETAIL DG

SWITCH-AWNING
108357-06-000
ACTUATOR-SWITCH
108356-12-CHT
CIRCUITS
FFD,FFR,FFE,
FFE,JJR,FFD

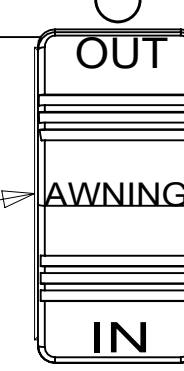

SWITCH-COACH BATT
108357-18-000
ACTUATOR-SWITCH
108356-19-CHT
CIRCUITS
KF,LG,LJ,LH,WC
WIRE ASM-THERM
186796-01-000

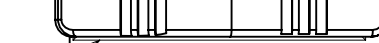

PLATE-SWITCH
158431-29-CHT
SEAL-FUSE BOX
092492-25-000
SCREW
000G11-06-10U (6)

SWITCH-CHASSIS BATTERY
108357-18-000
ACTUATOR-SWITCH
108356-20-CHT
CIRCUITS
UUC,TTY,UUB
UUB,TTZ,MK
WIRE ASM-THERM
186796-01-000

SWITCH-STEP
108357-19-000
CIRCUITS
ER,ES

DETAIL DH 1

2 PLACE AROUND ENTIRE PERIMETER WITH SEAM AT BOTTOM.

1 FOR SWITCH ORIENTATION SEE DETAIL DE

NOTES:

265 CODES/STANDARDS-CSA/CMVSS

1B1 CODES/STANDARDS USA

1B1 265

FOR ELECTRICAL TORQUE SPECIFICATIONS SEE DWG NO. 128783-01-000

FOR ELECTRICAL CALLOUTS SEE DWG NO. 121339-01-000

DESCRIPTION:
WIRING INSTL-BODY, 12V

SHEET: 4 OF 7 ITEM/PART NO.: 000177076 / 30044901000 REV:

8 7 6 5 4 3 2 1

D

D

C

C

B

B

A

A

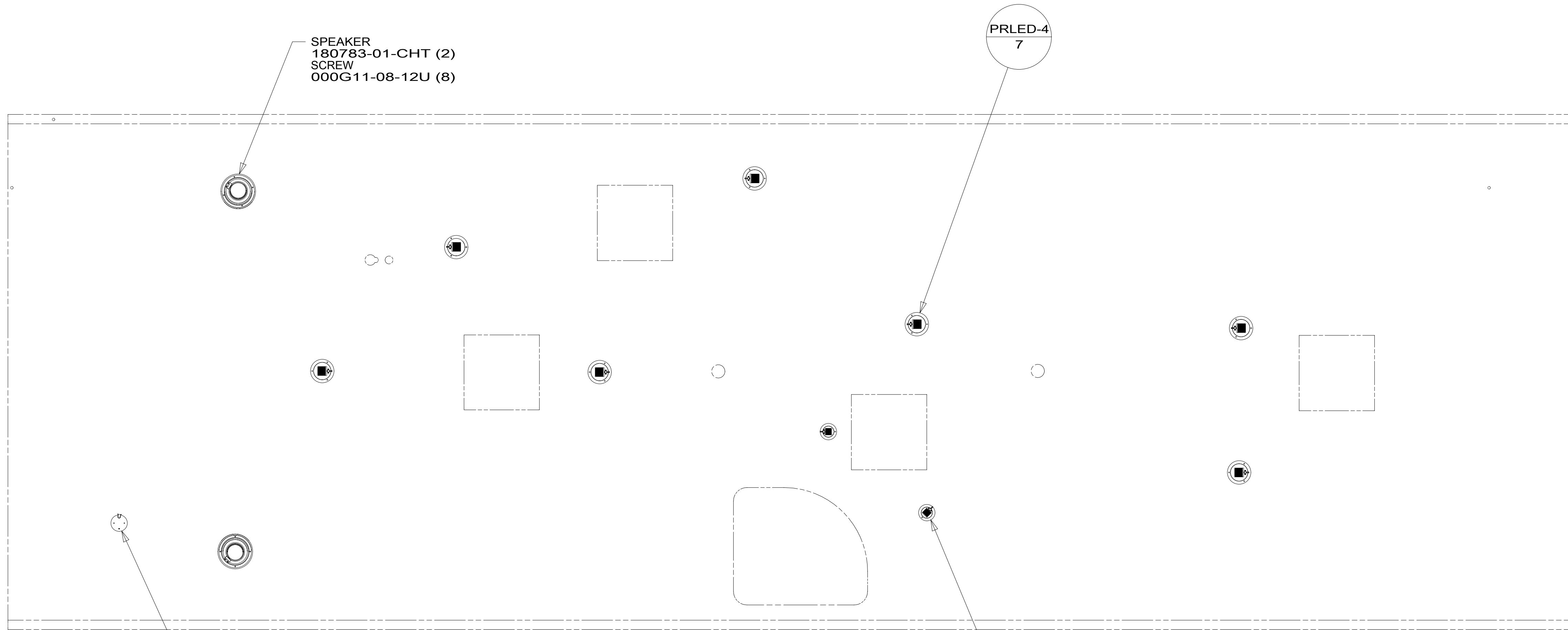

SPEAKER
 180783-01-CHT (2)
 SCREW
 000G11-08-12U (8)

PRLED-4
 7

PSSLED-2 45B

PRLED-2
 2

- 45B LOFT BED
- 265 CODES/STANDARDS-CSA/CMVSS
- 1B1 CODES/STANDARDS USA

FOR ELECTRICAL
 TORQUE
 SPECIFICATIONS
 SEE DWG NO.
 128783-01-000

FOR
 ELECTRICAL
 CALLOUTS
 SEE DWG NO.
 121339-01-000

DESCRIPTION:	1B1 265	
WIRING INSTL-BODY, 12V		
SHEET:	ITEM/PART NO:	REV
5 OF 7	000177076 / 30044901000	

8 7 6 5 4 3 2 1

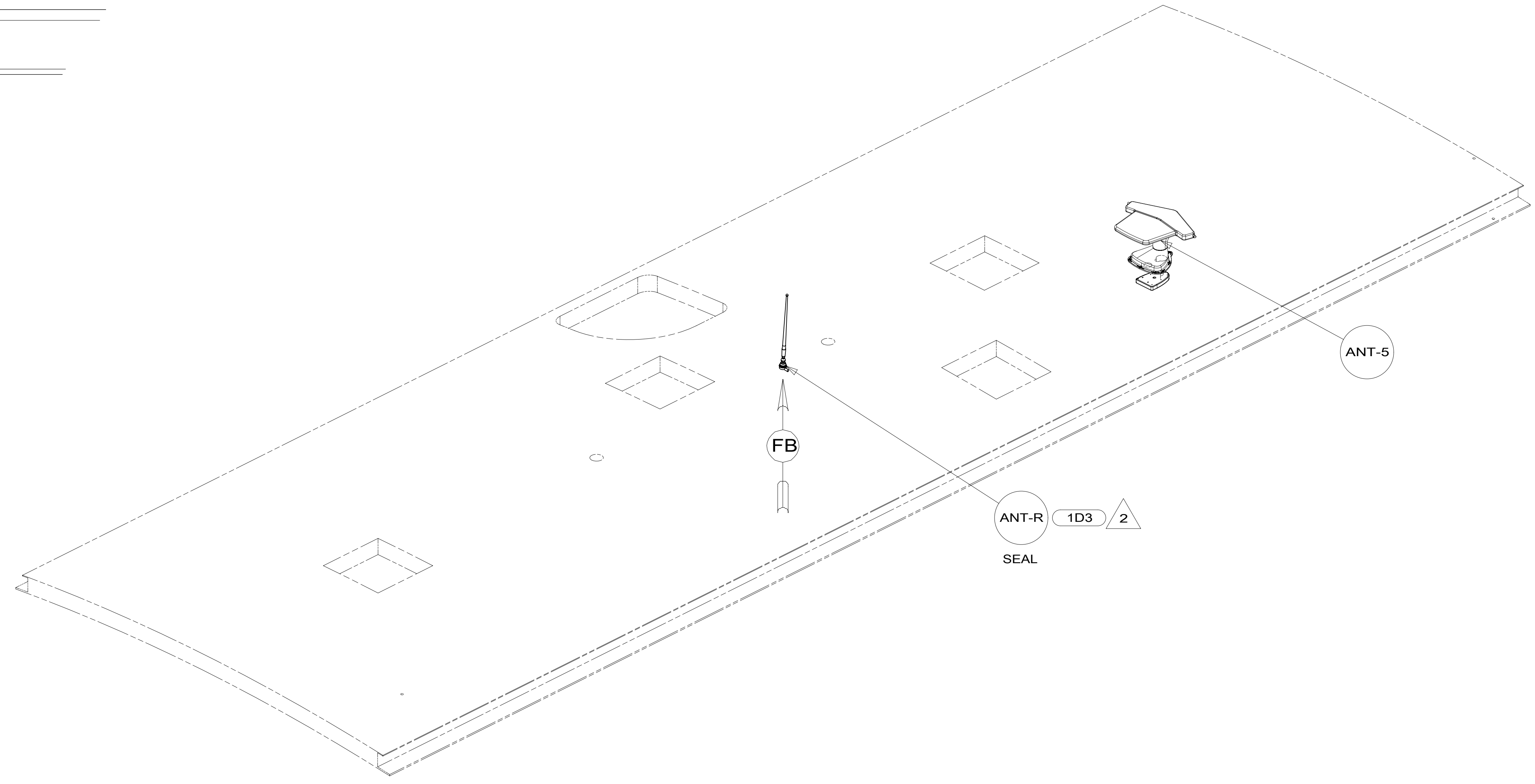
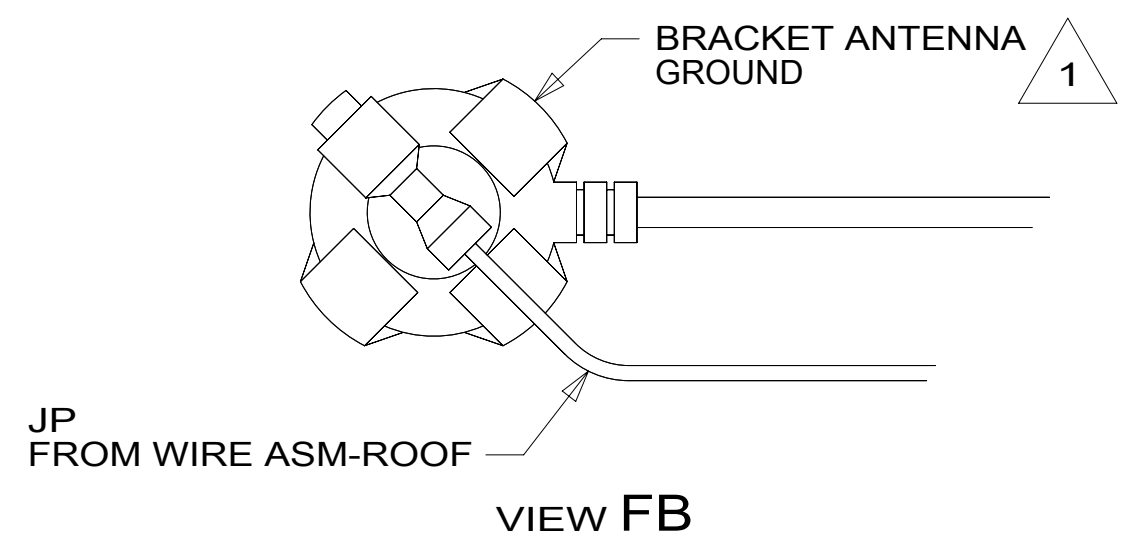
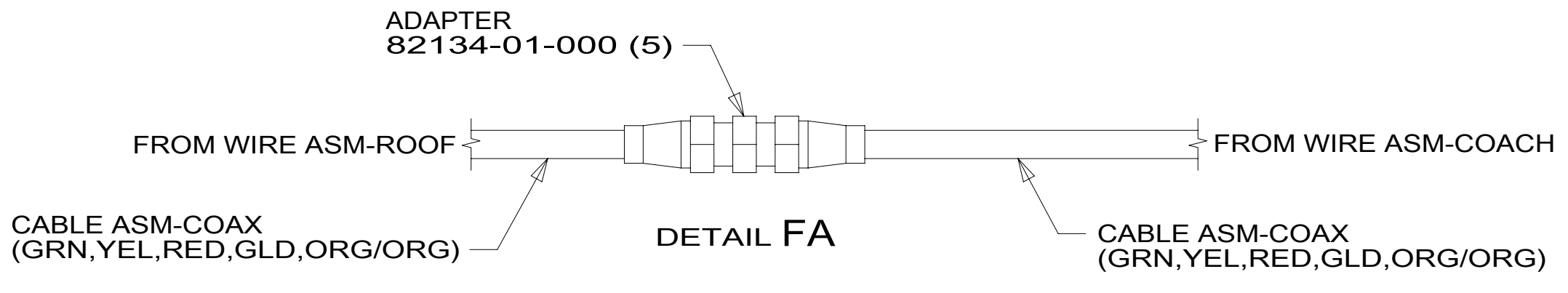

- NOTES:
- 2 REMOVE GROUND WIRE FROM ANTENNA BASE.
 - 1 WRAP LEGS AROUND ANTENNA BASE.

FOR ELECTRICAL
TORQUE
SPECIFICATIONS
SEE DWG NO.
128783-01-000

FOR
ELECTRICAL
CALLOUTS
SEE DWG NO.
121339-01-000

- 1D3 ENTERTAIN CENTR/EXT TV-DVD
- 265 CODES/STANDARDS-CSA/CMVSS
- 1B1 CODES/STANDARDS USA

DESCRIPTION:		1B1 265	
WIRING INSTL-BODY, 12V			
SHEET:	ITEM/PART NO.:	REV	
6 OF 7	000177076 / 30044901000		

8 7 6 5 4 3 2 1 20-Sep-2016

8 7 6 5 4 3 2 1

D
C
B
A

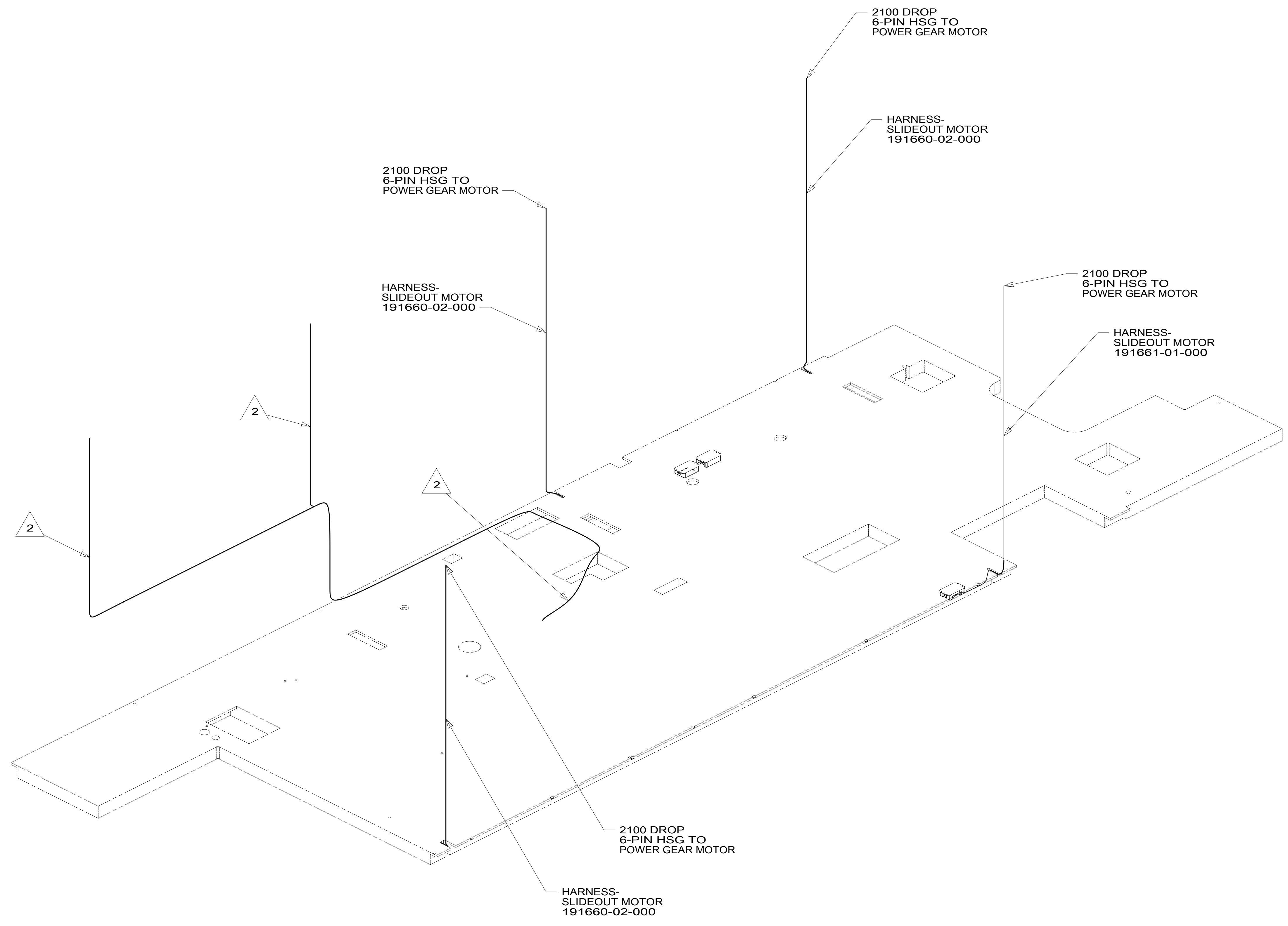

2 WIRING PART OF WIRE ASM-CHASSIS.

1. AT MINIMUM ALL WIRES TO BE SUPPORTED AND SECURED PER CODE REQUIREMENTS. USE CLAMP 10495 OR 10497 OR WIRE TIE 8343 OR 108046 AND SCREW G67-XX-XXX OR G56-XX-XXX AS APPROPRIATE FOR INSTALLATION.

NOTES:

265 CODES/STANDARDS-CSA/CMVSS
 1B1 CODES/STANDARDS USA

FOR ELECTRICAL TORQUE SPECIFICATIONS SEE DWG NO. 128783-01-000

FOR ELECTRICAL CALLOUTS SEE DWG NO. 121339-01-000

1B1 265	
DESCRIPTION: WIRING INSTL-BODY, 12V	
SHEET: 7 OF 7	ITEM/PART NO: 000177076 / 30044901000

8 7 6 5 4 3 2 1 20-Sep-2016