

- 1D3 PANEL-RECEPTACLE 151376-01-CHT SCREW G67-10-12U (4)
- 299 PANEL-RECEPTACLE 151376-02-CHT LABEL-COAX 157486-01-CHT ADAPTER 82134-01-000 NUT 82136-01-000 SCREW G67-10-12U (4)

- 299 ENTERTAINMENT CENTER EXT. W/O
- 1D3 ENTERTAIN CENTR/EXT TV-DVD
- 401 INVERTER-DC/AC, 1000 WATT
- 265 CODES/STANDARDS-CSA/CMVSS
- 1B1 CODES/STANDARDS USA

WINNEBAGO
COPYRIGHT 2016 WINNEBAGO INDUSTRIES, INC.

DSNR:	ALL DIMENSIONS ARE IN MILLIMETERS
DIFTR:	MATERIAL:
UNSPECIFIED TOLERANCES:	WEIGHT: (LBS)
WHOLE DIM (X) : 3	FIRST USED: 16 E35F
ONE-PLACE (X.X) : 1.5	
TWO-PLACE (X.XX) : 0.50	
ANGLE : 1°	
REFER TO ES0018 FOR FASTENER TIGHTENING GUIDELINES	
DESCRIPTION:	
WIRING INSTL-BODY, 12V	
SHEET: 1 OF 8	ITEM/PART NO: 000173537 / 30055501000
REF:	1 19-Sep-2016

- 4 WIRE PASSES THROUGH FLOOR IN THIS AREA.
 - 3 PLACE CROSS LOCATOR ON SENSORS OVER DIMPLES ON TANK.
2. ROUTE TANK SENSOR WIRES SO THEY DO NOT PASS OVER SENSORS. USE WIRE TIE MOUNT 155366-01-000 AND WIRE TIE 8343-01-000 AS NEEDED. TANK SURFACE MUST BE CLEANED USING ISOPROPYL ALCOHOL AND PRIMED WITH PRIMER 94.
 1. AT MINIMUM ALL WIRES TO BE SUPPORTED AND SECURED PER CODE REQUIREMENTS. USE CLAMP 10495 OR 10497 OR WIRE TIE 8343 OR 108046 AND SCREW G67-XX-XXX OR G56-XX-XXX AS APPROPRIATE FOR INSTALLATION.

FOR ELECTRICAL TORQUE SPECIFICATIONS SEE DWG NO. 128783-01-000

X-X FOR ELECTRICAL CALLOUTS SEE DWG NO. 121339-01-000

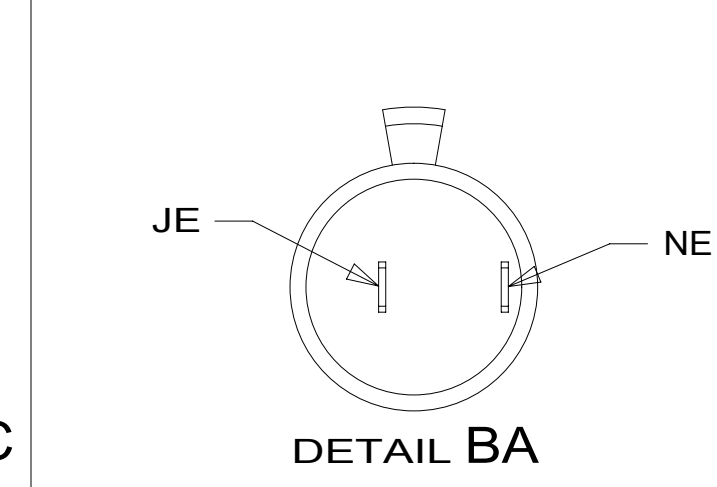
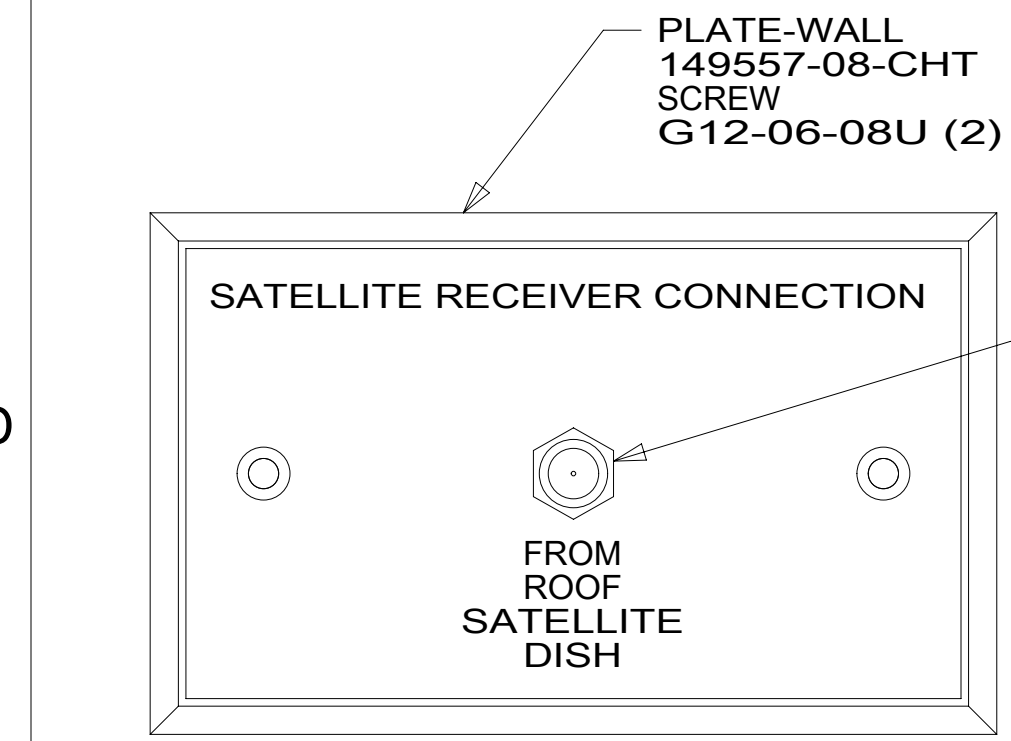
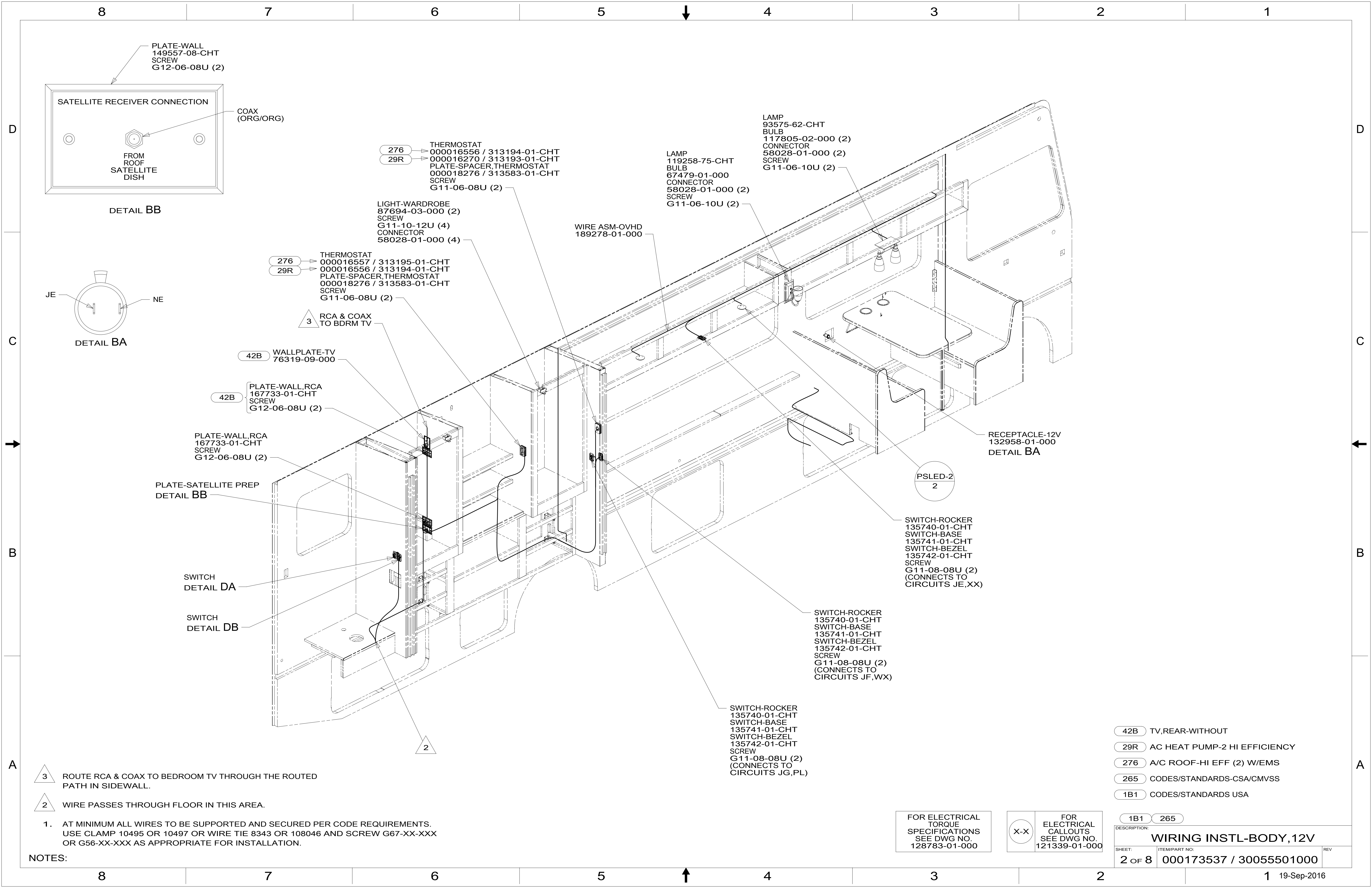

- 3 ROUTE RCA & COAX TO BEDROOM TV THROUGH THE ROUTED PATH IN SIDEWALL.
- 2 WIRE PASSES THROUGH FLOOR IN THIS AREA.

NOTES:
 1. AT MINIMUM ALL WIRES TO BE SUPPORTED AND SECURED PER CODE REQUIREMENTS. USE CLAMP 10495 OR 10497 OR WIRE TIE 8343 OR 108046 AND SCREW G67-XX-XXX OR G56-XX-XXX AS APPROPRIATE FOR INSTALLATION.

- 42B TV,REAR-WITHOUT
- 29R AC HEAT PUMP-2 HI EFFICIENCY
- 276 A/C ROOF-HI EFF (2) W/EMS
- 265 CODES/STANDARDS-CSA/CMVSS
- 1B1 CODES/STANDARDS USA

FOR ELECTRICAL TORQUE SPECIFICATIONS SEE DWG NO. 128783-01-000

X-X FOR ELECTRICAL CALLOUTS SEE DWG NO. 121339-01-000

DESCRIPTION:		1B1 265	
WIRING INSTL-BODY, 12V			
SHEET:	ITEM/PART NO.:	REV:	
2 OF 8	000173537 / 30055501000		

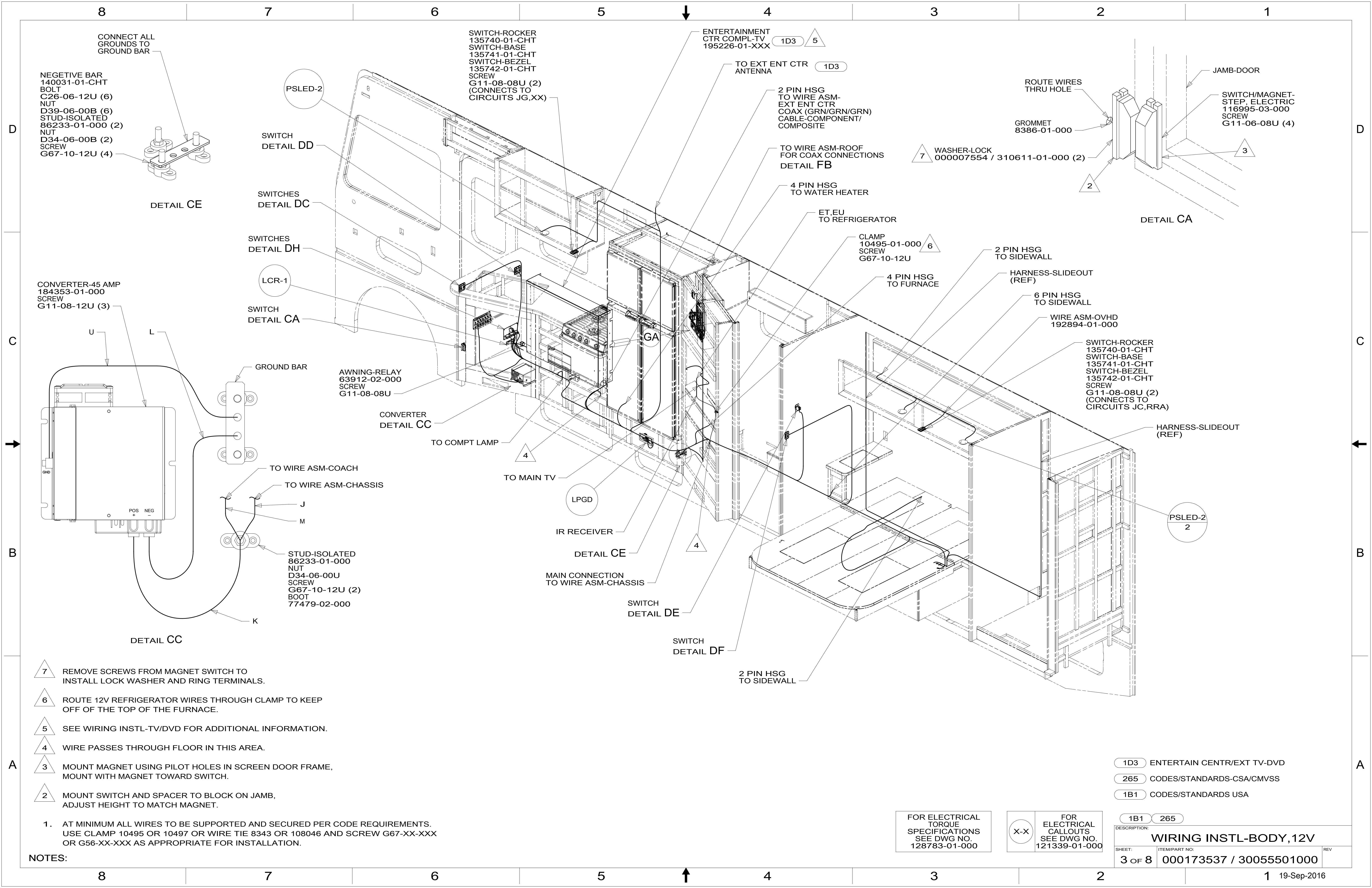

CONNECT ALL GROUNDS TO GROUND BAR

NEGATIVE BAR
140031-01-CHT
BOLT
C26-06-12U (6)
NUT
D39-06-00B (6)
STUD-ISOLATED
86233-01-000 (2)
NUT
D34-06-00B (2)
SCREW
G67-10-12U (4)

DETAIL CE

CONVERTER-45 AMP
184353-01-000
SCREW
G11-08-12U (3)

GROUND BAR

AWNING-RELAY
63912-02-000
SCREW
G11-08-08U

CONVERTER
DETAIL CC

TO WIRE ASM-COACH

TO WIRE ASM-CHASSIS

J

M

STUD-ISOLATED
86233-01-000
NUT
D34-06-00U
SCREW
G67-10-12U (2)
BOOT
77479-02-000

K

DETAIL CC

SWITCH-ROCKER
135740-01-CHT
SWITCH-BASE
135741-01-CHT
SWITCH-BEZEL
135742-01-CHT
SCREW
G11-08-08U (2)
(CONNECTS TO
CIRCUITS JG,XX)

PSLED-2

SWITCH
DETAIL DD

SWITCHES
DETAIL DC

SWITCHES
DETAIL DH

SWITCH
DETAIL CA

GROUND BAR

AWNING-RELAY
63912-02-000
SCREW
G11-08-08U

CONVERTER
DETAIL CC

TO COMPT LAMP

TO MAIN TV

LPGD

IR RECEIVER

DETAIL CE

MAIN CONNECTION
TO WIRE ASM-CHASSIS

SWITCH
DETAIL DE

SWITCH
DETAIL DF

2 PIN HSG
TO SIDEWALL

ENTERTAINMENT
CTR COMPL-TV
195226-01-XXX

1D3 5

TO EXT ENT CTR
ANTENNA

1D3

2 PIN HSG
TO WIRE ASM-
EXT ENT CTR
COAX (GRN/GRN/GRN)
CABLE-COMPONENT/
COMPOSITE

TO WIRE ASM-ROOF
FOR COAX CONNECTIONS
DETAIL FB

4 PIN HSG
TO WATER HEATER

ET,EU
TO REFRIGERATOR

CLAMP
10495-01-000
SCREW
G67-10-12U

4 PIN HSG
TO FURNACE

2 PIN HSG
TO SIDEWALL

HARNESS-SLIDEOUT
(REF)

6 PIN HSG
TO SIDEWALL

WIRE ASM-OVHD
192894-01-000

SWITCH-ROCKER
135740-01-CHT
SWITCH-BASE
135741-01-CHT
SWITCH-BEZEL
135742-01-CHT
SCREW
G11-08-08U (2)
(CONNECTS TO
CIRCUITS JC,RRA)

HARNESS-SLIDEOUT
(REF)

ROUTE WIRES
THRU HOLE

GROMMET
8386-01-000

WASHER-LOCK
000007554 / 310611-01-000 (2)

DETAIL CA

JAMB-DOOR

SWITCH/MAGNET-
STEP, ELECTRIC
116995-03-000
SCREW
G11-06-08U (4)

PSLED-2
2

- 7 REMOVE SCREWS FROM MAGNET SWITCH TO INSTALL LOCK WASHER AND RING TERMINALS.
- 6 ROUTE 12V REFRIGERATOR WIRES THROUGH CLAMP TO KEEP OFF OF THE TOP OF THE FURNACE.
- 5 SEE WIRING INSTL-TV/DVD FOR ADDITIONAL INFORMATION.
- 4 WIRE PASSES THROUGH FLOOR IN THIS AREA.
- 3 MOUNT MAGNET USING PILOT HOLES IN SCREEN DOOR FRAME, MOUNT WITH MAGNET TOWARD SWITCH.
- 2 MOUNT SWITCH AND SPACER TO BLOCK ON JAMB, ADJUST HEIGHT TO MATCH MAGNET.

1. AT MINIMUM ALL WIRES TO BE SUPPORTED AND SECURED PER CODE REQUIREMENTS. USE CLAMP 10495 OR 10497 OR WIRE TIE 8343 OR 108046 AND SCREW G67-XX-XXX OR G56-XX-XXX AS APPROPRIATE FOR INSTALLATION.

NOTES:

- 1D3 ENTERTAIN CENTR/EXT TV-DVD
- 265 CODES/STANDARDS-CSA/CMVSS
- 1B1 CODES/STANDARDS USA

FOR ELECTRICAL
TORQUE
SPECIFICATIONS
SEE DWG NO.
128783-01-000

FOR ELECTRICAL
CALLOUTS
SEE DWG NO.
121339-01-000

DESCRIPTION: WIRING INSTL-BODY, 12V	
SHEET: 3 OF 8	ITEM/PART NO: 000173537 / 30055501000
REV 19-Sep-2016	

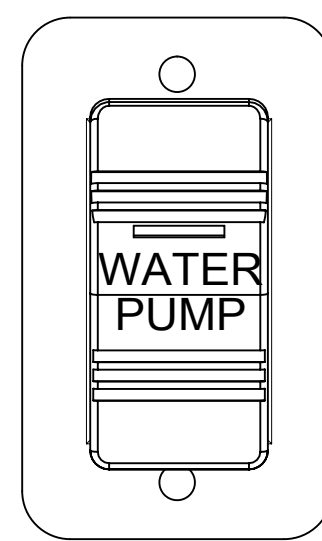

SWITCH-PUMP
108357-15-000
ACTUATOR
108356-23-CHT
PLATE
98351-07-CHT
SCREW
G11-06-10U (2)

DETAIL DA

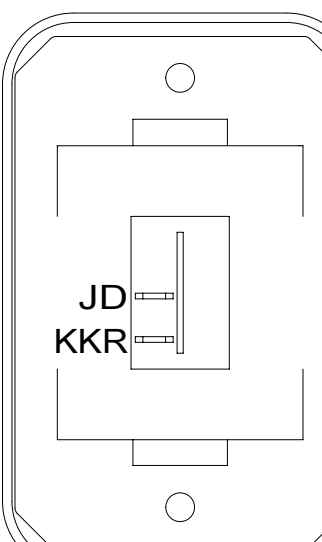

SWITCH-ROCKER
135740-01-CHT
SWITCH-BASE
135741-01-CHT
SWITCH-BEZEL
135742-01-CHT
SCREW
G11-08-08U (2)

DETAIL DB

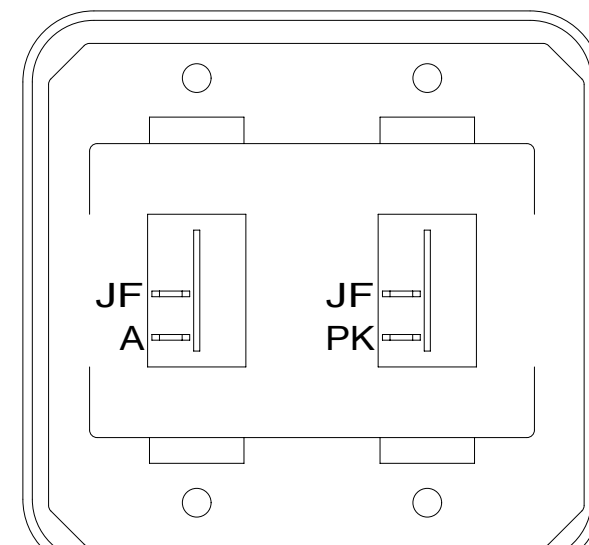

SWITCH-ROCKER
135740-01-CHT (2)
SWITCH-BASE
135741-02-CHT
SWITCH-BEZEL
135742-02-CHT
SCREW
G11-08-08U (4)

DETAIL DC

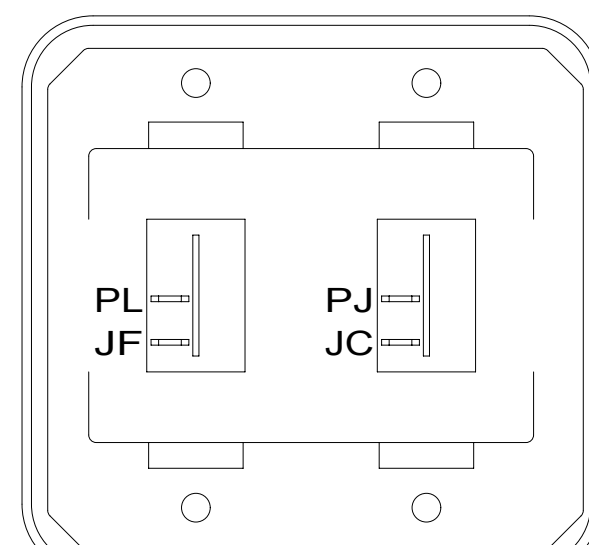

SWITCH-ROCKER
135740-01-CHT (2)
SWITCH-BASE
135741-02-CHT
SWITCH-BEZEL
135742-02-CHT
SCREW
G11-08-08U (4)

DETAIL DD

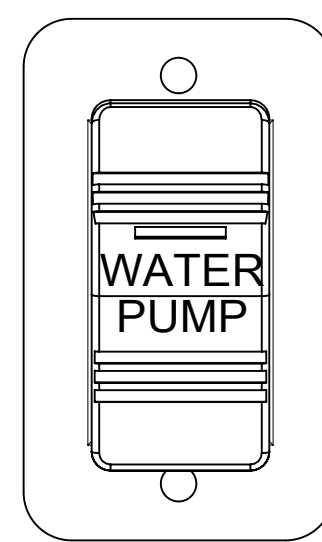

SWITCH-PUMP
108357-15-000
ACTUATOR
108356-23-CHT
PLATE
98351-07-CHT
SCREW
G11-06-10U (2)

DETAIL DE

SWITCH-CHASSIS BATTERY
108357-18-000
ACTUATOR-SWITCH
108356-20-CHT
CIRCUITS TTZ,UUB,
TTY,UUC,MK
WIRE ASM-THERM
186796-01-000

SWITCH-COACH BATT
108357-18-000
ACTUATOR-SWITCH
108356-19-CHT
CIRCUITS LH,LJ,
LG,KF,WC
WIRE ASM-THERM
186796-01-000

SWITCH-AWNING
108357-06-000
ACTUATOR-SWITCH
108356-12-CHT
CIRCUITS
FFD,FFR,FFE,
FFE,JJR,FFD

PLATE-SWITCH
158431-15-CHT
SCREW
G11-06-10U (6)

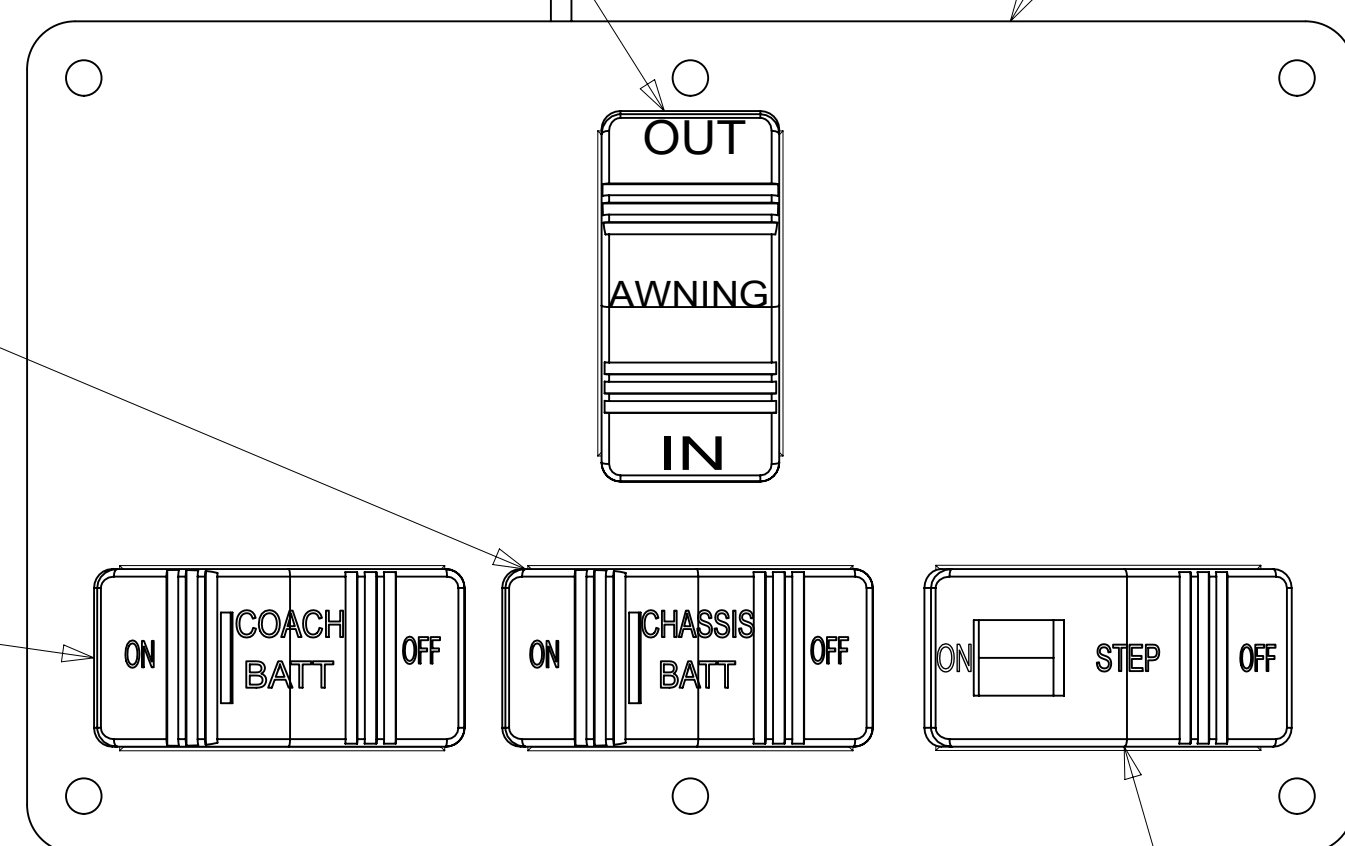

DETAIL DH 1

SCREW
G11-10-12U (4)

SCREW
G52-06-04B (12)

M
6 BLK

PLATE
139067-02-CHT

SCREW
G39-08-06B (2)

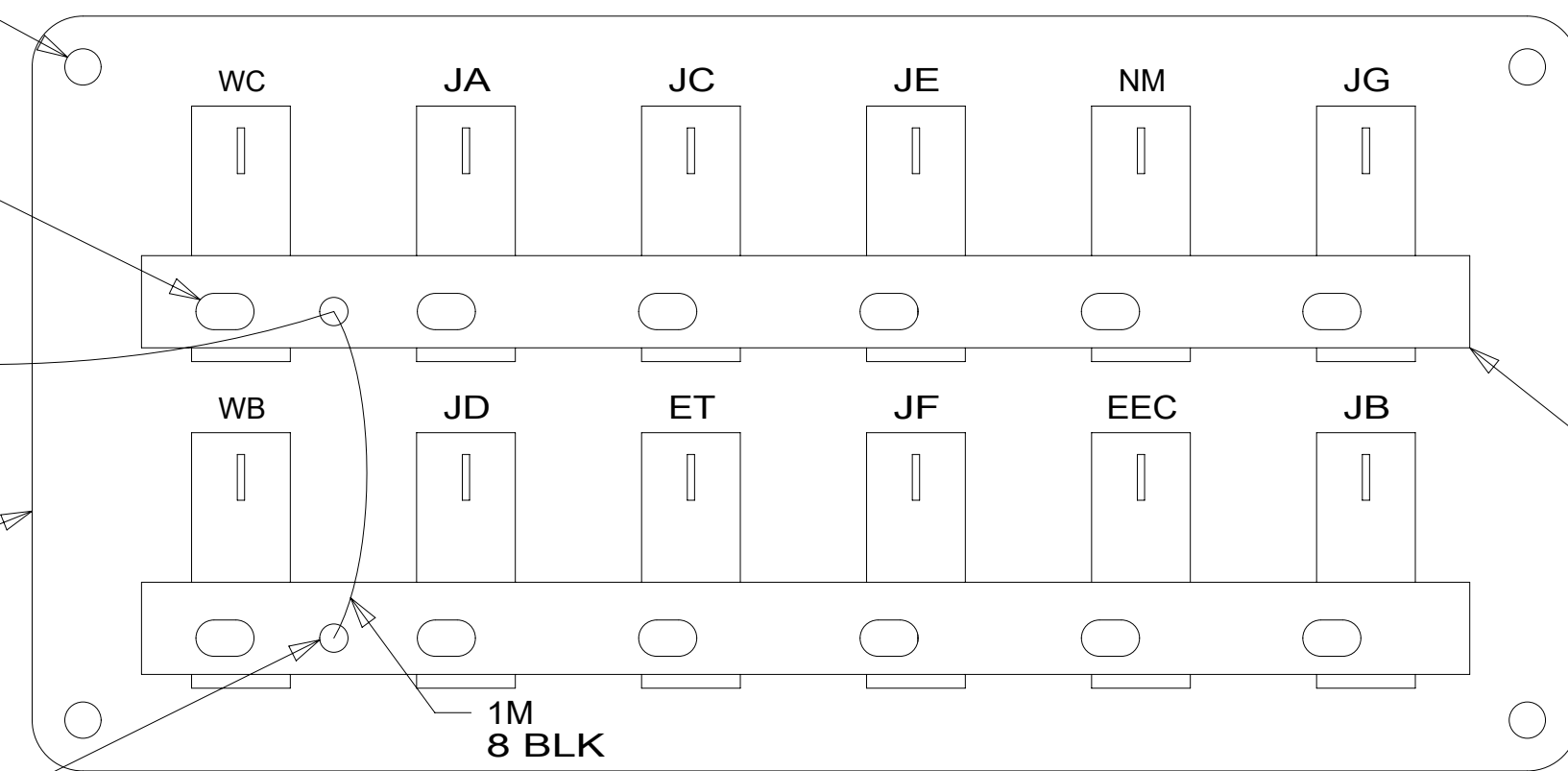

DETAIL DK
(BACK VIEW)

DL

DL

BUSS BAR
92786-05-000 (2)

HOUSING 12V CIRCUIT BREAKERS

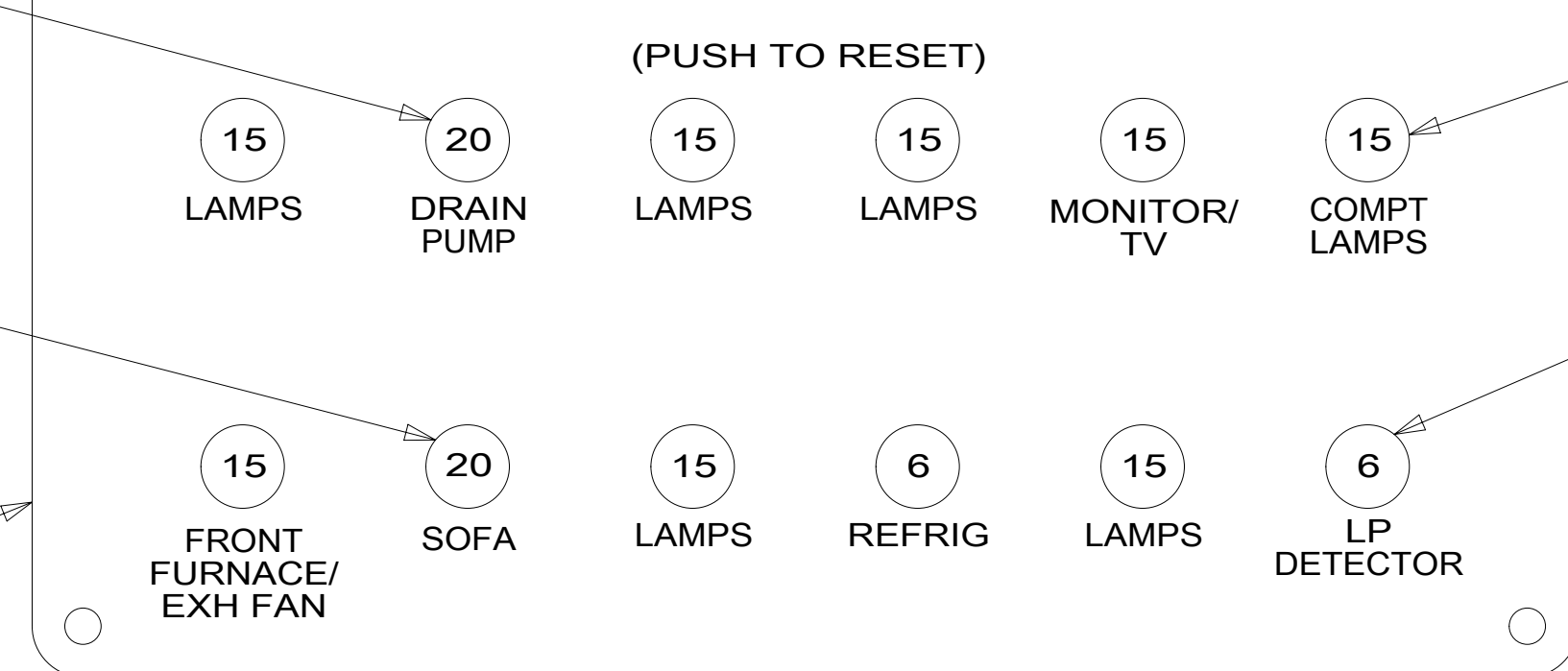

DETAIL DK
(FRONT VIEW)

CIRCUIT BREAKER
93654-02-000 (8)

CIRCUIT BREAKER
93654-01-000 (2)

PLUG
81211-06-000
CIRCUIT BREAKER
93654-03-000

LABEL
92547-16-000

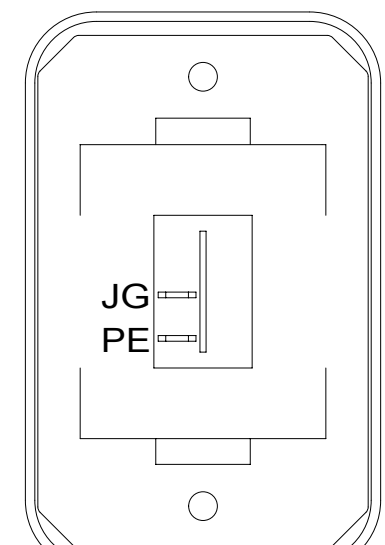

SWITCH-ROCKER
135740-01-CHT
SWITCH-BASE
135741-01-CHT
SWITCH-BEZEL
135742-01-CHT
SCREW
G11-08-08U (2)

DETAIL DF

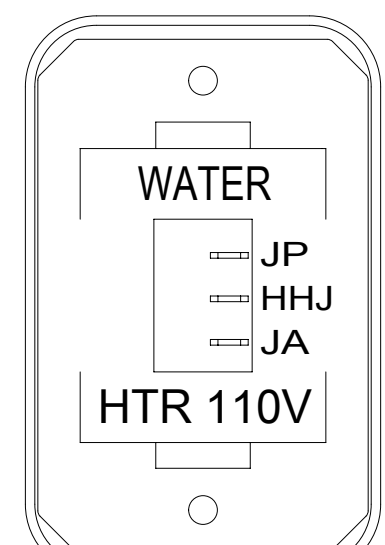

SWITCH-ROCKER
135740-06-CHT
SWITCH-BASE
135741-01-CHT
SWITCH-BEZEL
135742-35-CHT
SCREW
G11-08-08U (2)

DETAIL DG

LABEL-SLIDEOUT,
DRIVER,FRONT
163992-01-CHT

SWITCH
108357-18-000
ACTUATOR
108356-31-CHT
(CIRCUITS:DR,DU,
KE,ABY,ABZ)

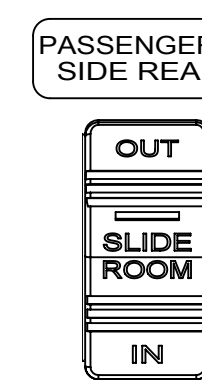
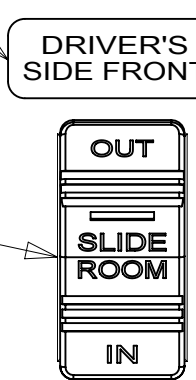

LABEL-SLIDEOUT,
PASS,REAR
163992-03-CHT

SWITCH
108357-18-000
ACTUATOR
108356-31-CHT
(CIRCUITS:HHH,KE,
HHG,ACC,ACD)

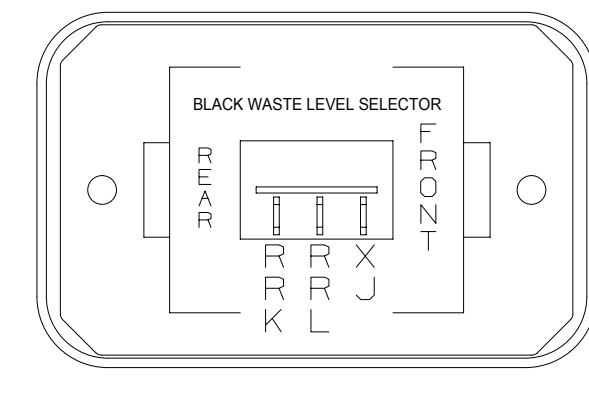

DETAIL DM

SWITCH-ROCKER
135740-02-CHT
SWITCH-BASE
135741-01-CHT
SWITCH-BEZEL
135742-61-CHT
SCREW
G11-08-08U (2)

WARNING CRUSH HAZARD. Keep people and objects clear of the inside and the outside of the slideout room when operating. Failure to comply could result in death or serious injury.

LABEL-WARNING,SLIDEOUT
116549-01-000

DETAIL DJ

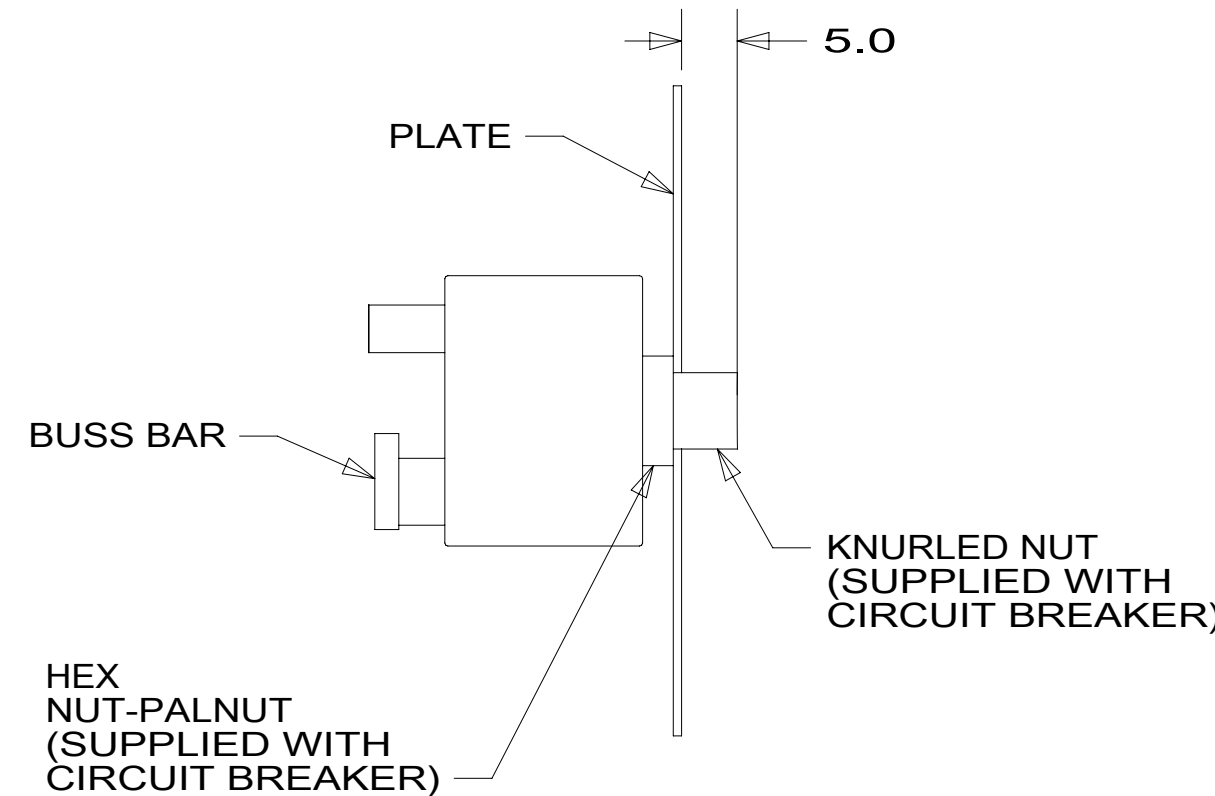

VIEW DL-DL

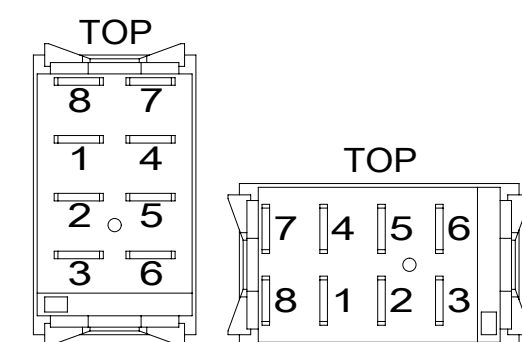

DETAIL DN

- 45B LOFT BED
- 45D LOFT BED - WITHOUT
- 265 CODES/STANDARDS-CSA/CMVSS
- 1B1 CODES/STANDARDS USA

FOR ELECTRICAL
TORQUE
SPECIFICATIONS
SEE DWG NO.
128783-01-000

FOR ELECTRICAL
CALLOUTS
SEE DWG NO.
121339-01-000

DESCRIPTION:	1B1 265	
WIRING INSTL-BODY, 12V		
SHEET:	ITEM/PART NO:	REV
4 OF 8	000173537 / 30055501000	

NOTES:
1 FOR SWITCH ORIENTATION SEE DETAIL DN

8 7 6 5 4 3 2 1

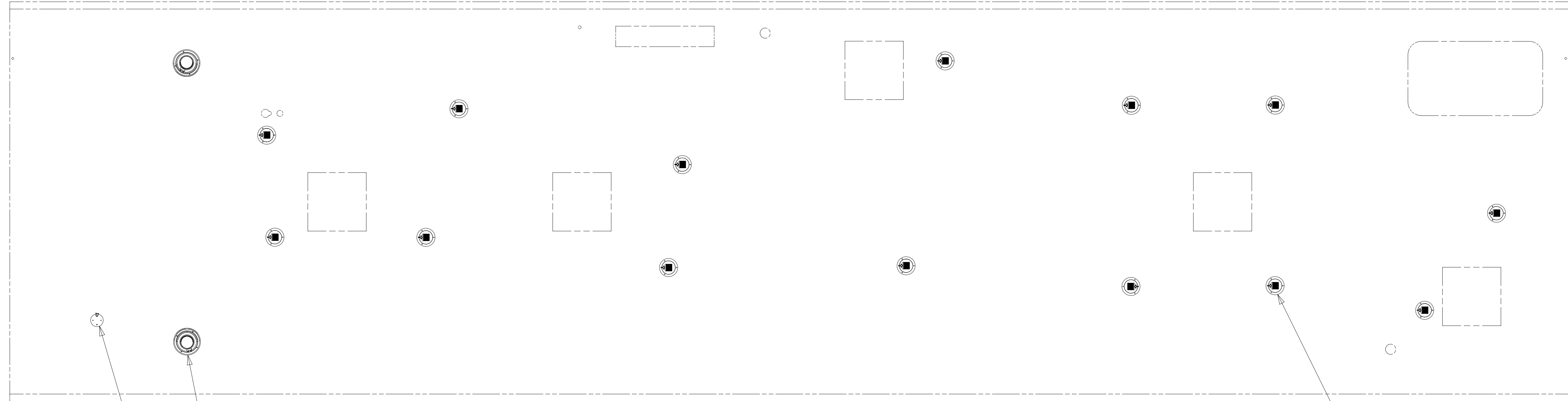

PSSLED-2
 SPEAKER-ROUND, CEILING
 180783-01-CHT (2)
 SCREW
 000G11-08-12U (8)

PRLED-4
 14

LO1-3

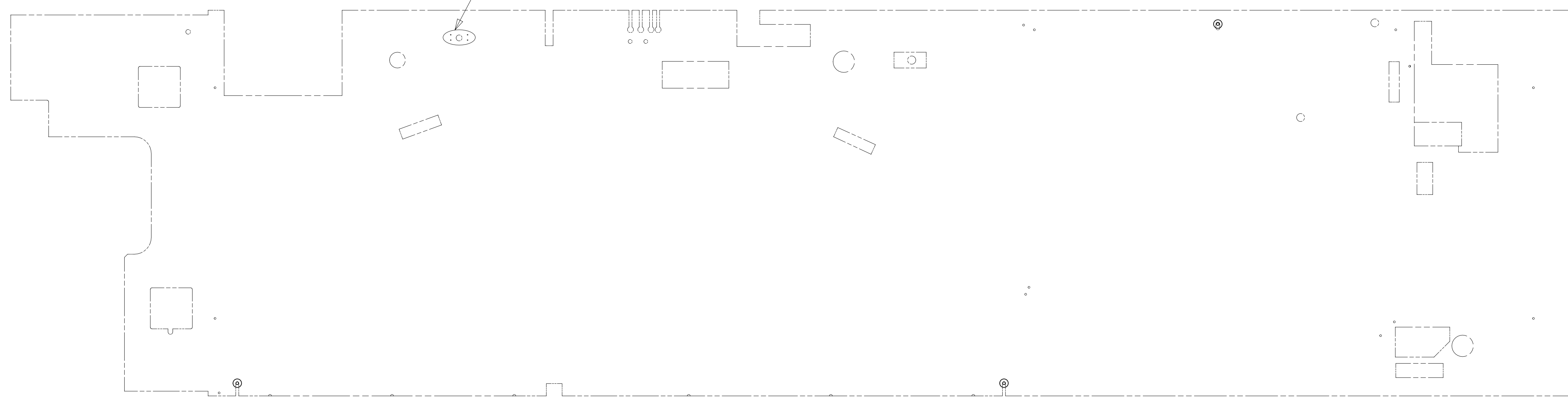

- 45B LOFT BED
- 265 CODES/STANDARDS-CSA/CMVSS
- 1B1 CODES/STANDARDS USA

FOR ELECTRICAL
 TORQUE
 SPECIFICATIONS
 SEE DWG NO.
 128783-01-000

X-X
 FOR
 ELECTRICAL
 CALLOUTS
 SEE DWG NO.
 121339-01-000

DESCRIPTION:		1B1 265
WIRING INSTL-BODY, 12V		
SHEET:	ITEM/PART NO.:	REV
5 OF 8	000173537 / 30055501000	

8 7 6 5 4 3 2 1 19-Sep-2016

8 7 6 5 4 3 2 1

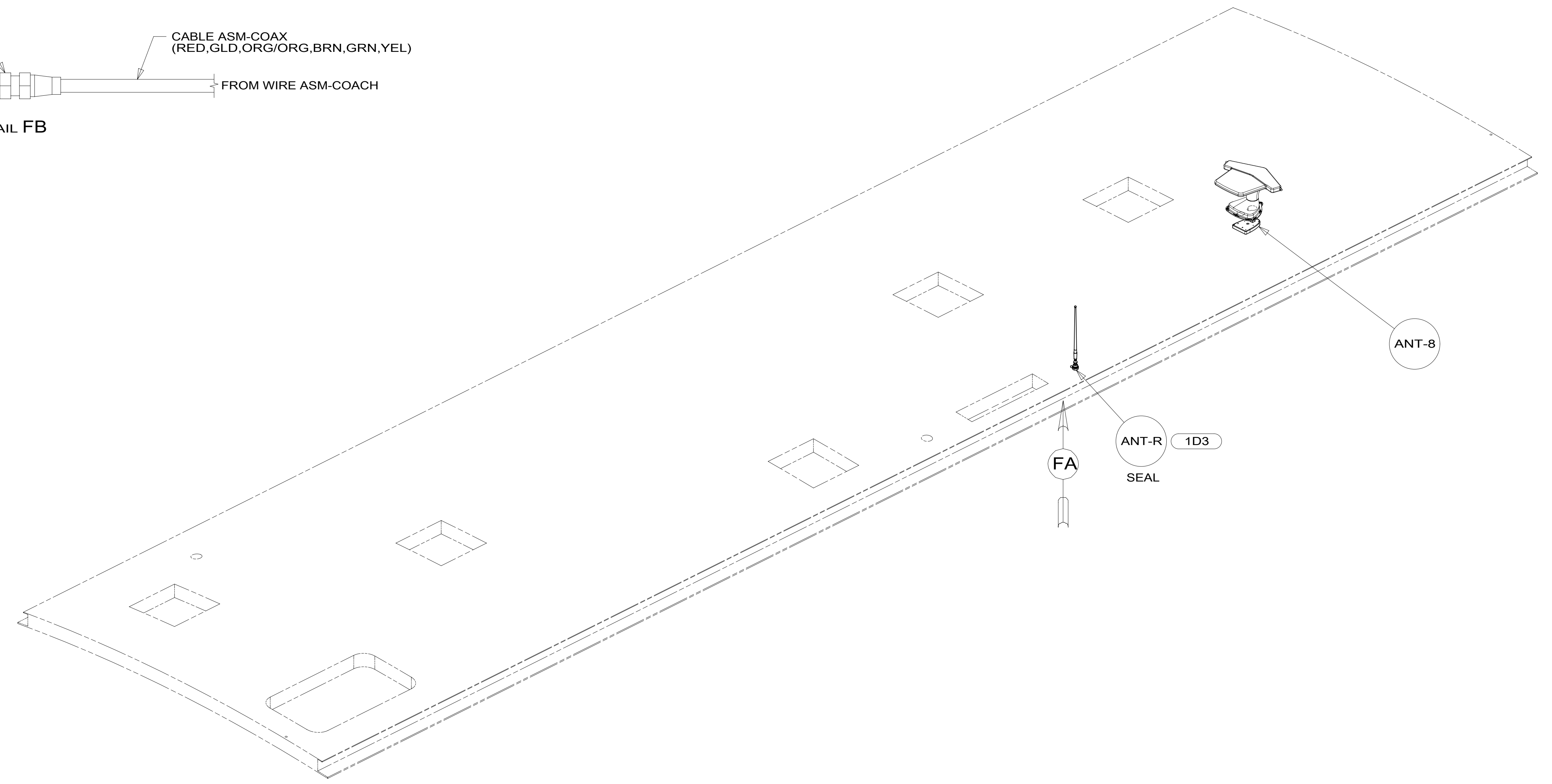
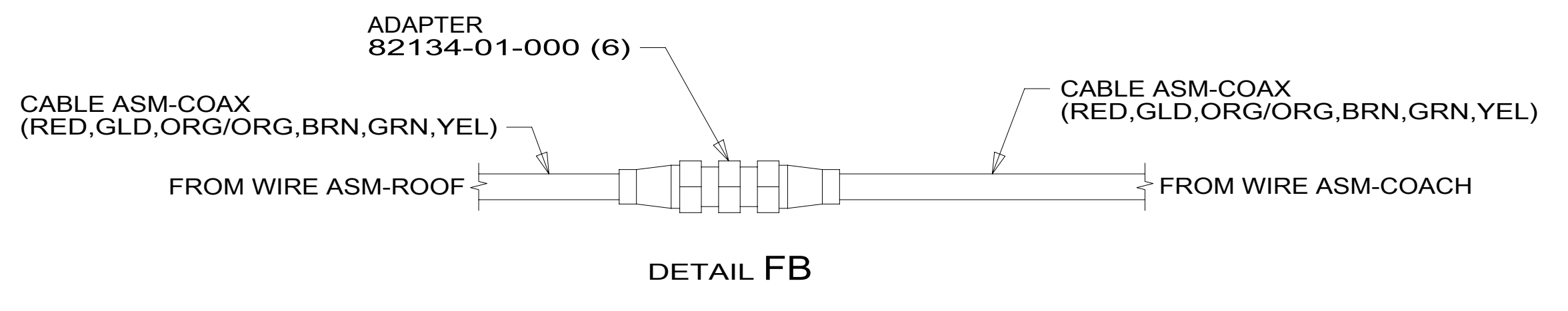
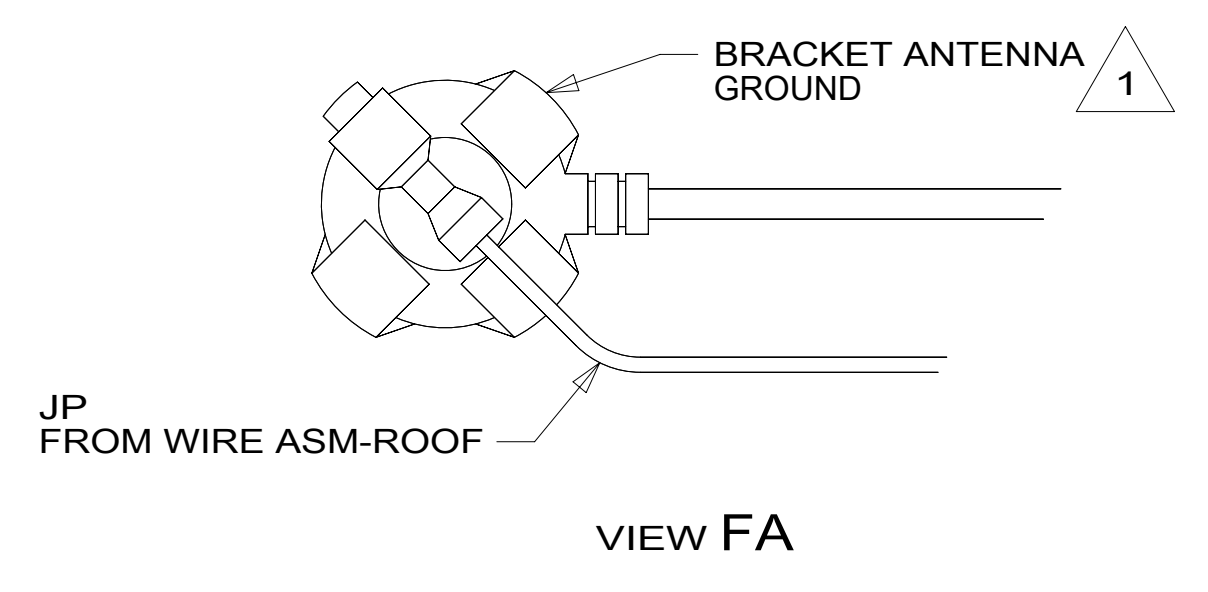

NOTES:

1 WRAP LEGS AROUND ANTENNA BASE.

FOR ELECTRICAL TORQUE SPECIFICATIONS SEE DWG NO. 128783-01-000

FOR ELECTRICAL CALLOUTS SEE DWG NO. 121339-01-000

- 1D3 ENTERTAIN CENTR/EXT TV-DVD
- 265 CODES/STANDARDS-CSA/CMVSS
- 1B1 CODES/STANDARDS USA

DESCRIPTION:		1B1 265	
WIRING INSTL-BODY, 12V			
SHEET:	ITEM/PART NO.:	REV	
6 OF 8	000173537 / 30055501000		

8 7 6 5 4 3 2 1 19-Sep-2016

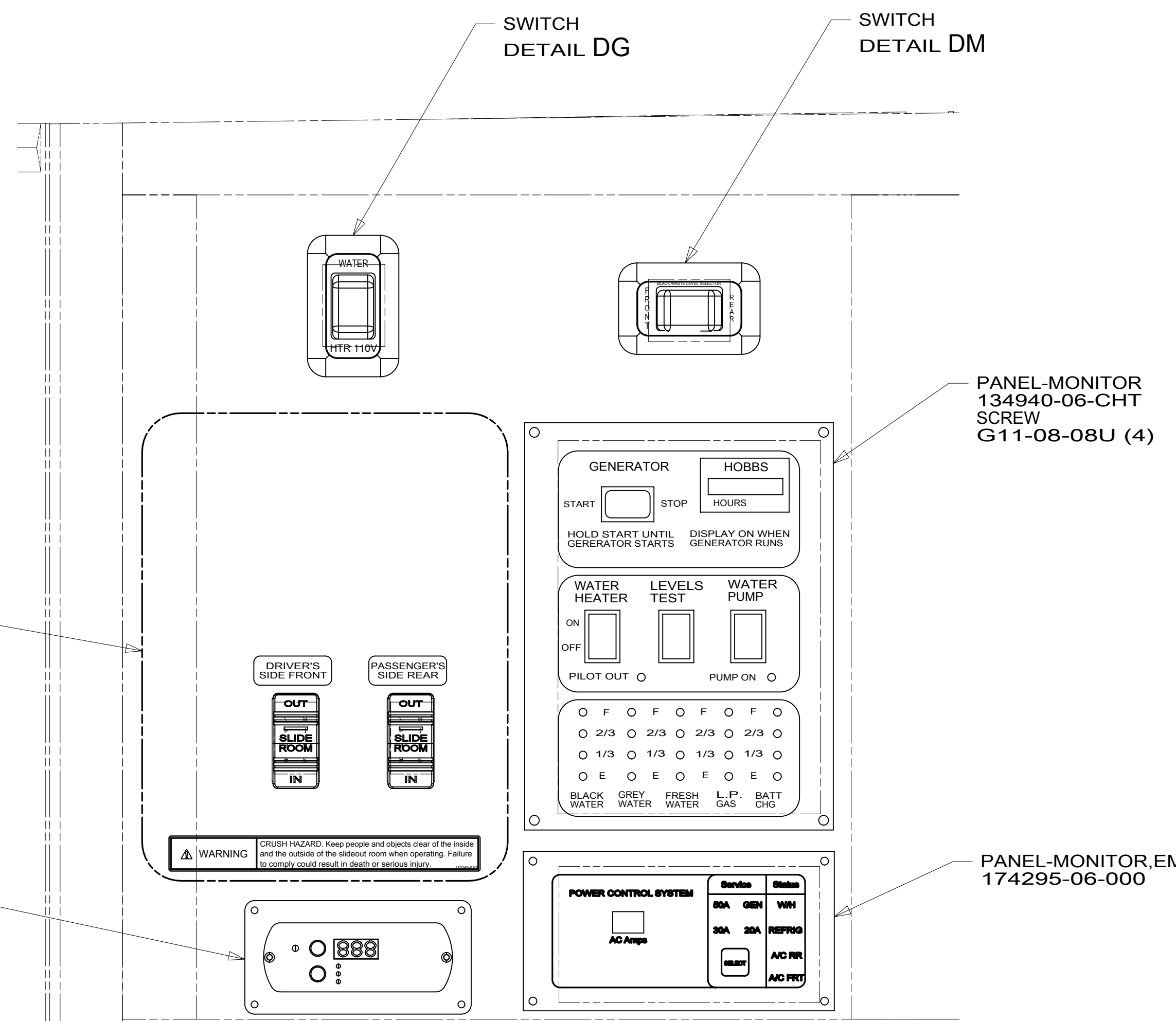

VIEW GA

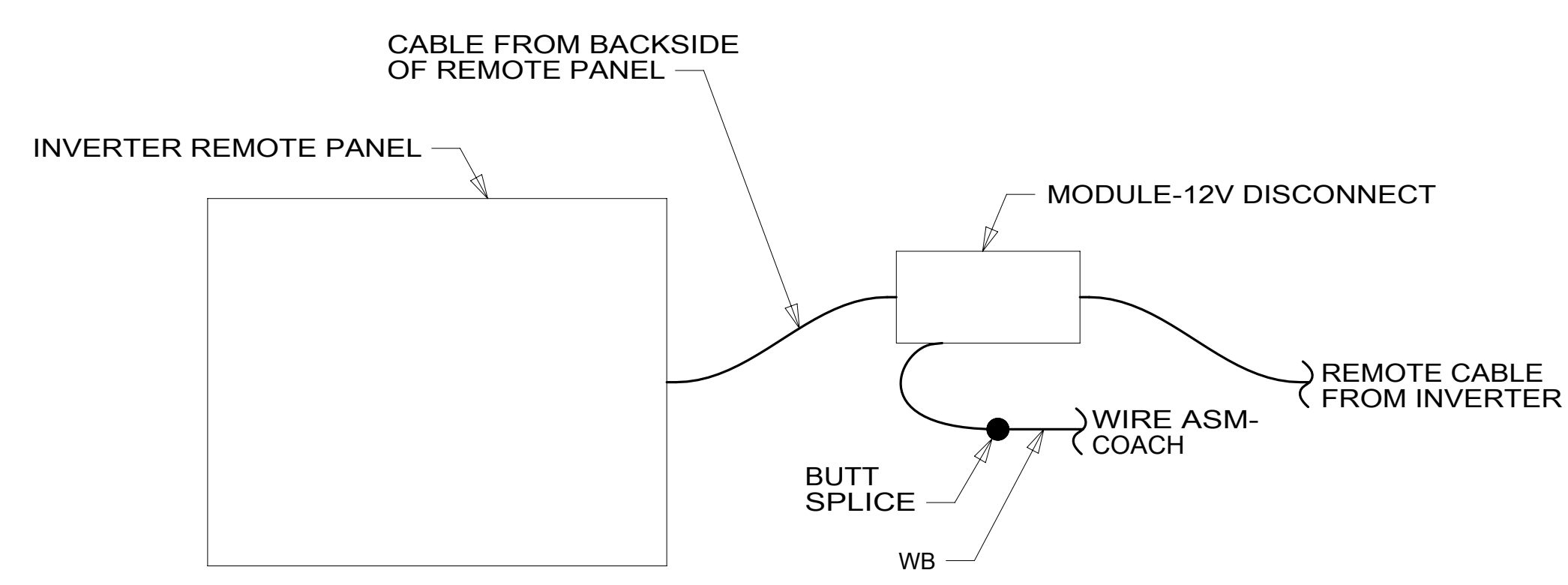

2 DATA CABLE FOR EMS PANEL IS MARKED WITH RED TAPE.

1. AT MINIMUM ALL WIRES TO BE SUPPORTED AND SECURED PER CODE REQUIREMENTS. USE CLAMP 10495 OR 10497 OR WIRE TIE 8343 OR 108046 AND SCREW G67-XX-XXX OR G56-XX-XXX AS APPROPRIATE FOR INSTALLATION.

NOTES:

FOR ELECTRICAL TORQUE SPECIFICATIONS SEE DWG NO. 128783-01-000

FOR ELECTRICAL CALLOUTS SEE DWG NO. 121339-01-000

- 401 INVERTER-DC/AC, 1000 WATT
- 265 CODES/STANDARDS-CSA/CMVSS
- 1B1 CODES/STANDARDS USA

DESCRIPTION:		1B1 265	
WIRING INSTL-BODY, 12V			
SHEET:	ITEM/PART NO.:	REV	
7 OF 8	000173537 / 30055501000		

8 7 6 5 4 3 2 1

D

D

C

C

B

B

A

A

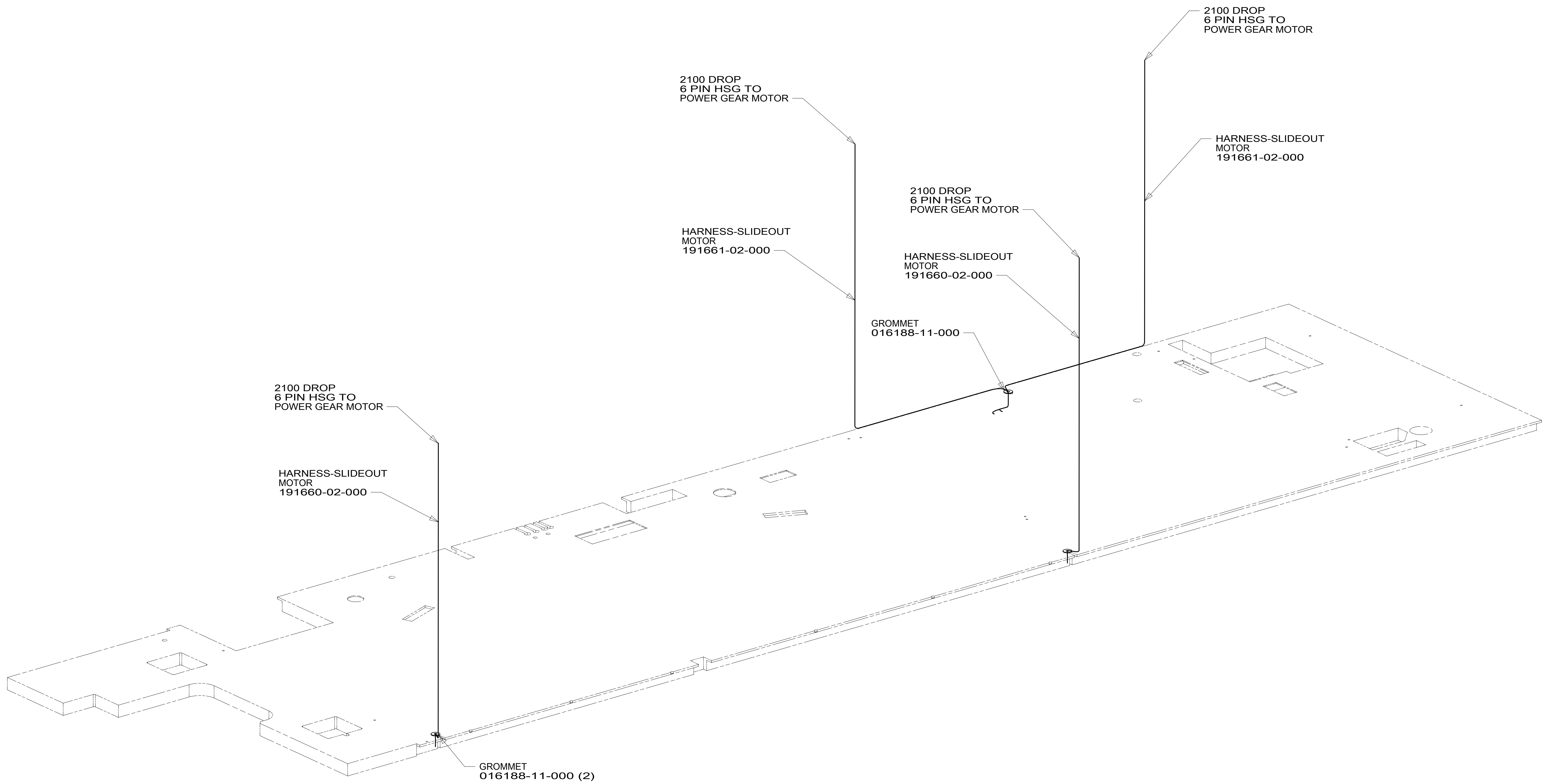

265 CODES/STANDARDS-CSA/CMVSS
 1B1 CODES/STANDARDS USA

FOR ELECTRICAL TORQUE SPECIFICATIONS SEE DWG NO. 128783-01-000

X-X FOR ELECTRICAL CALLOUTS SEE DWG NO. 121339-01-000

1B1 265	
DESCRIPTION: WIRING INSTL-BODY, 12V	
SHEET: 8 OF 8	ITEM/PART NO: 000173537 / 30055501000
REV	