



**DANGER**

**Danger of electrical shock, burns or death.** Always remove all power sources before attempting any repair, service or diagnostic work. Power can be present from shore power, generator, inverter or battery. All power sources must be disabled and secured before performing any service.



**CAUTION**

If you lack the skills, tools or equipment to perform diagnostic or repair work leave such work to an authorized Winnebago Industries dealer or other qualified shop.

DRAWING NO.	FEATURES
190243-01	-----
190243-11	1B1 12D
190243-15	265 12D

RELEASE	REV/DATE	DWG NO	190243
REV ZONE	REVISION RECORD	DATE	DFT-ORIG

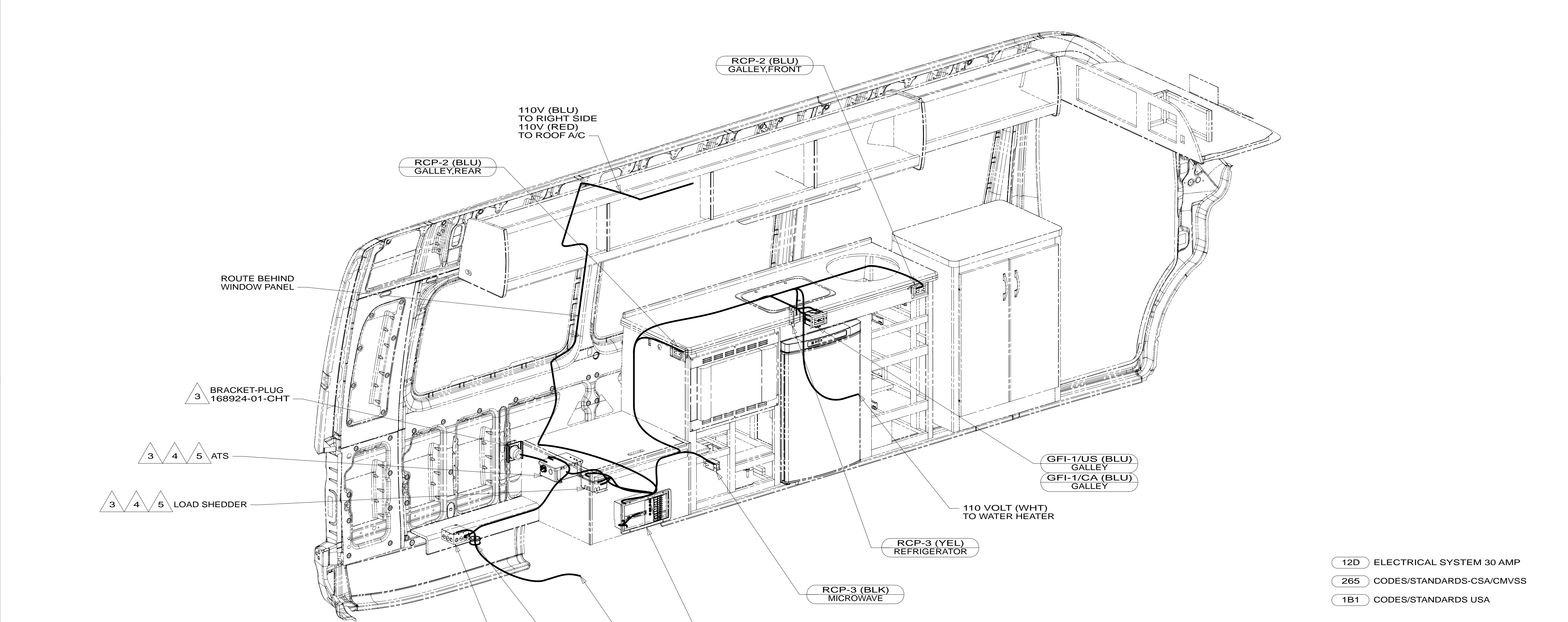

- 5 LOAD CENTER AND ATS GROUND WIRES MUST BE ATTACHED DIRECTLY TO CHASSIS GROUND.
- 4 GROUND WIRES (8 GA WIRE) FROM LOAD CENTER AND ATS ROUTES THROUGH FLOOR TO GROUND BOLT UNDER DRIVER'S SEAT.
- 3 SEE LOAD CENTER/ATS ASM FOR ADDITIONAL INFORMATION.
2. ALL 110V WIRES TO BE CLAMPED WITH CLAMP 10497-05-000 WITHIN 200MM OF OUTLET BOXES, USE SCREW G67-10-12B.
1. AT MINIMUM ALL WIRES TO BE SUPPORTED AND SECURED PER CODE REQUIREMENTS. USE CLAMP 10495 OR 10497 OR WIRE TIE 8343 OR 108046 AND SCREW G67-XX-XXX OR G56-XX-XXX AS APPROPRIATE FOR INSTALLATION.

NOTES:

- 12D ELECTRICAL SYSTEM 30 AMP
- 265 CODES/STANDARDS-CSA/CMVSS
- 1B1 CODES/STANDARDS USA

1B1 265 12D



DFT-ORIG	ORIG. DATE
CHKR	ALL DIMENSIONS ARE IN MILLIMETERS
P.E.	
M.E.	
DSNR	FIRST USED
<b>15 170X</b>	
UNSPECIFIED TOLERANCES ARE:	
WHOLE DIM (X)	: 3
ONE-PLACE (X.X)	: 1.5
TWO-PLACE (X.XX)	: 0.50
ANGLE	: 1°
THIRD ANGLE PROJECTION	
DO NOT SCALE DRAWING REFER TO ES0018 FOR FASTENER TIGHTENING GUIDELINES	

FOR ELECTRICAL TORQUE SPECIFICATIONS SEE DWG NO. 128783-01-000

FOR ELECTRICAL CALLOUTS SEE DWG NO. 121339-01-000

TITLE: <b>WIRING INSTL-BODY, 110V</b>	
SHEET 1 OF 3	PART NO <b>190243</b> REV

\* 190243 \* A

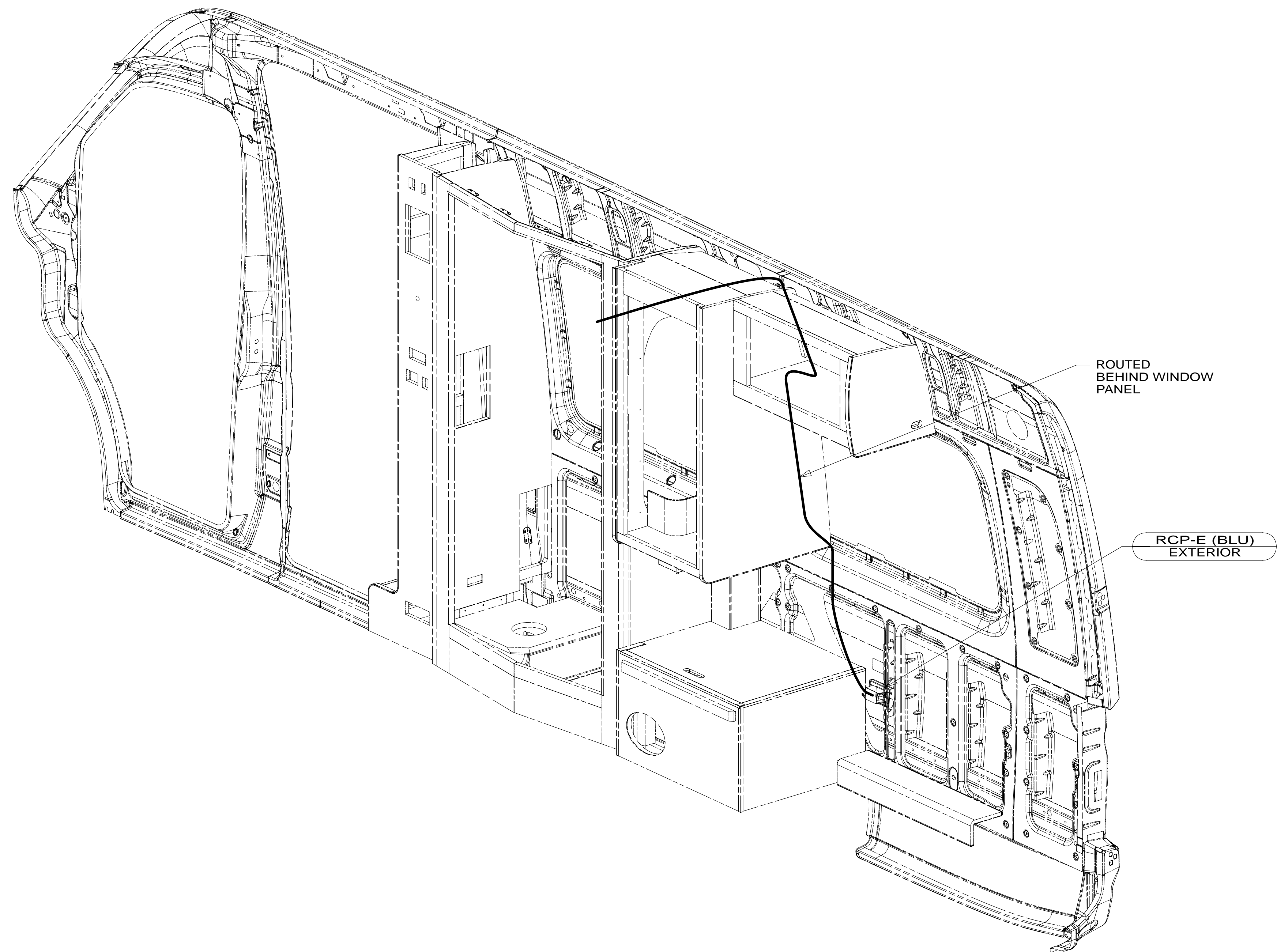

- NOTES:
1. AT MINIMUM ALL WIRES TO BE SUPPORTED AND SECURED PER CODE REQUIREMENTS. USE CLAMP 10495 OR 10497 OR WIRE TIE 8343 OR 108046 AND SCREW G67-XX-XXX OR G56-XX-XXX AS APPROPRIATE FOR INSTALLATION.
  2. ALL 110V WIRES TO BE CLAMPED WITH CLAMP 10497-05-000 WITHIN 200MM OF OUTLET BOXES, USE SCREW G67-10-12B.

- 12D ELECTRICAL SYSTEM 30 AMP
- 265 CODES/STANDARDS-CSA/CMVSS
- 1B1 CODES/STANDARDS USA

1B1 265 12D

FIRST USED	
<b>15 170X</b>	
DO NOT SCALE DRAWING	
TITLE: <b>WIRING INSTL-BODY, 110V</b>	
SHEET 2	PART NO <b>190243</b> REV

FOR ELECTRICAL TORQUE SPECIFICATIONS SEE DWG NO. 128783-01-000

FOR ELECTRICAL CALLOUTS SEE DWG NO. 121339-01-000

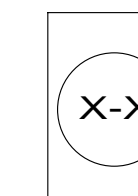

\* 190243 \* A

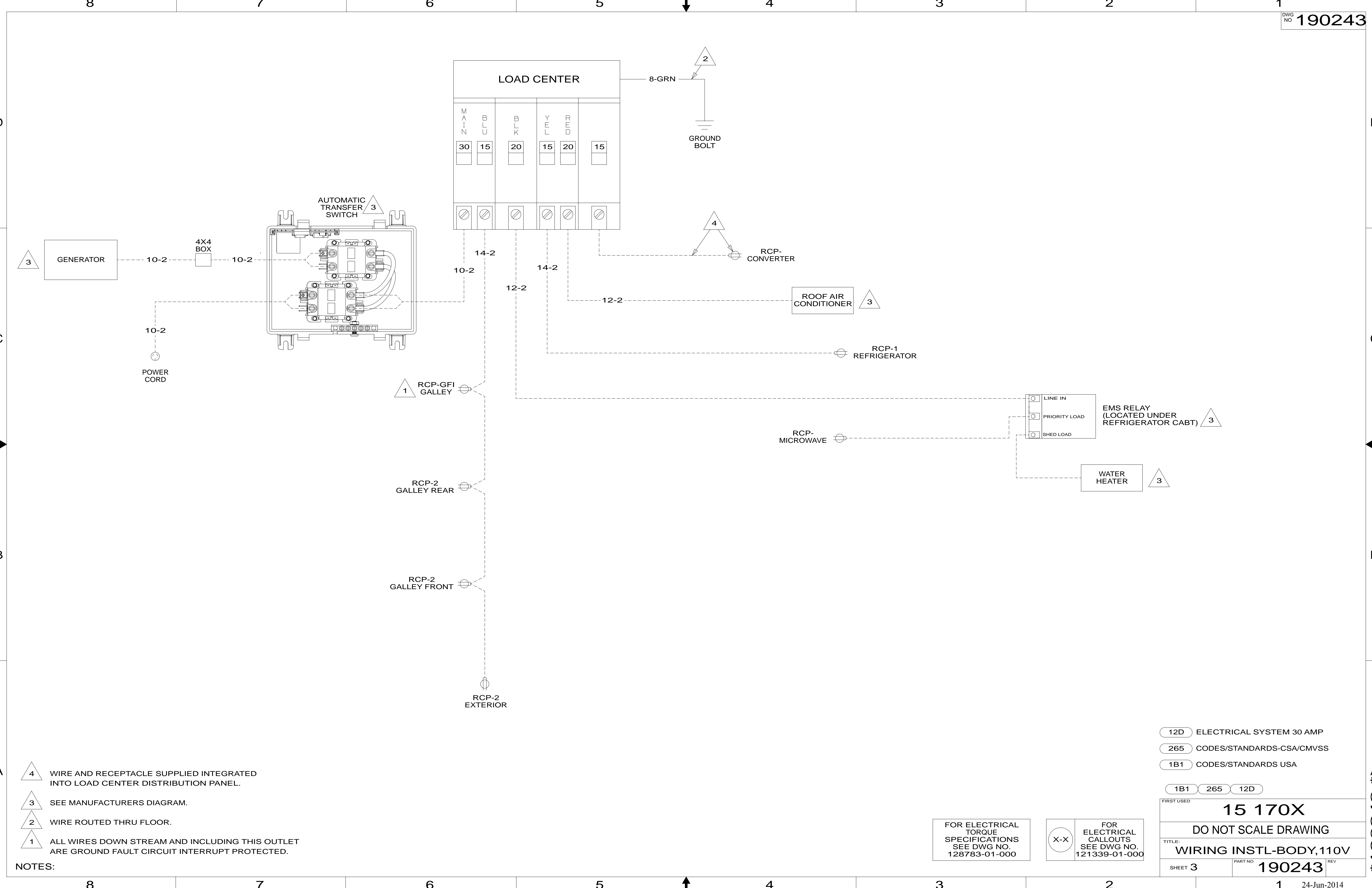

- NOTES:
- 4 WIRE AND RECEPTACLE SUPPLIED INTEGRATED INTO LOAD CENTER DISTRIBUTION PANEL.
  - 3 SEE MANUFACTURERS DIAGRAM.
  - 2 WIRE ROUTED THRU FLOOR.
  - 1 ALL WIRES DOWN STREAM AND INCLUDING THIS OUTLET ARE GROUND FAULT CIRCUIT INTERRUPT PROTECTED.

- 12D ELECTRICAL SYSTEM 30 AMP
- 265 CODES/STANDARDS-CSA/CMVSS
- 1B1 CODES/STANDARDS USA

1B1 265 12D

FIRST USED **15 170X**

DO NOT SCALE DRAWING

TITLE: **WIRING INSTL-BODY, 110V**

SHEET 3 PART NO **190243** REV

FOR ELECTRICAL TORQUE SPECIFICATIONS SEE DWG NO. 128783-01-000

FOR ELECTRICAL CALLOUTS SEE DWG NO. 121339-01-000

\* 190243 \* A