



**DANGER**

**Danger of electrical shock, burns or death.** Always remove all power sources before attempting any repair, service or diagnostic work. Power can be present from shore power, generator, inverter or battery. All power sources must be disabled and secured before performing any service.



**CAUTION**

If you lack the skills, tools or equipment to perform diagnostic or repair work leave such work to an authorized Winnebago Industries dealer or other qualified shop.

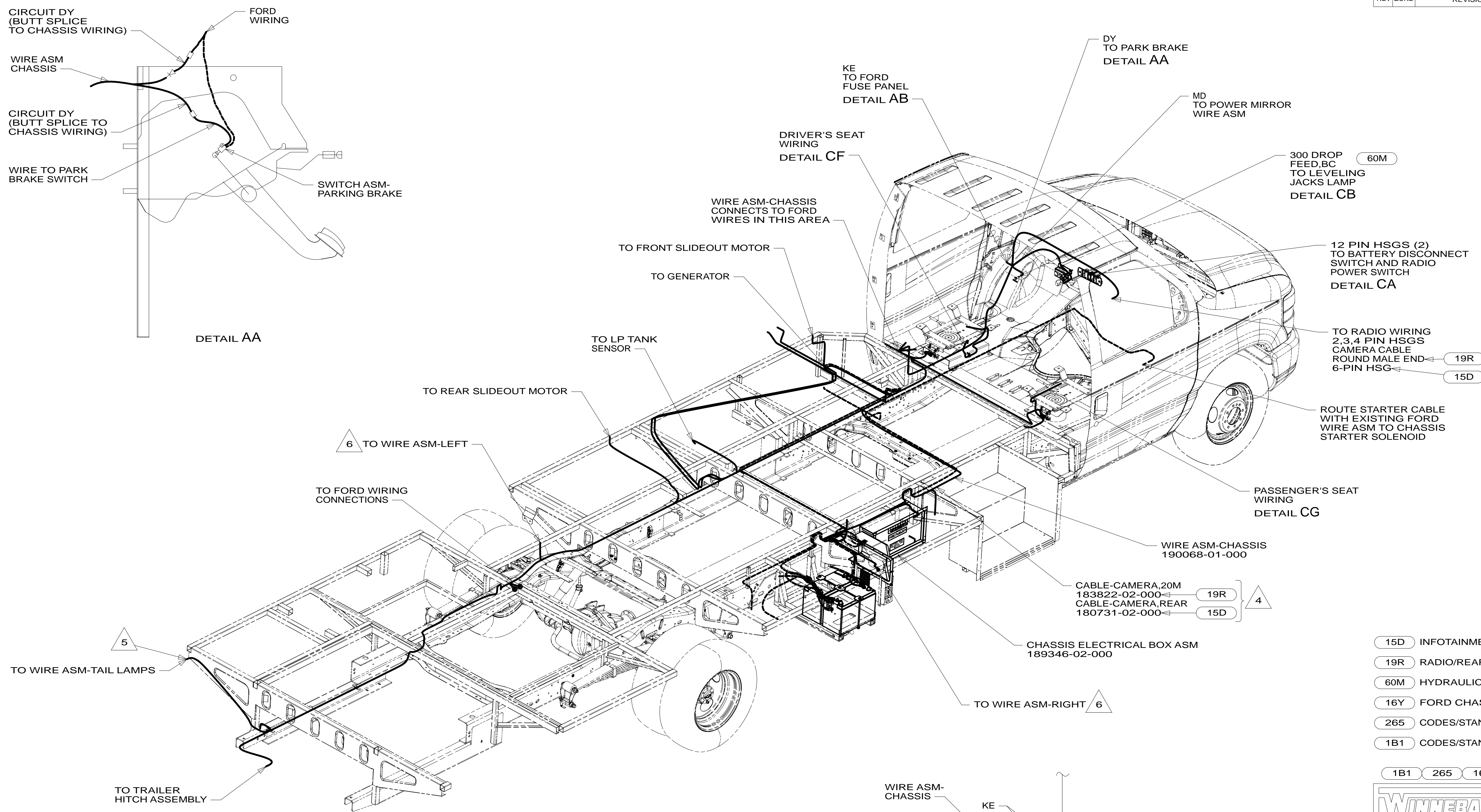

- 15D INFOTAINMENT CENTER/GPS
- 19R RADIO/REARVIEW MONITOR SYS
- 60M HYDRAULIC LEVEL JACKS-AUTO
- 16Y FORD CHASSIS - 14,500#\_GVWR
- 265 CODES/STANDARDS-CSA/CMVSS
- 1B1 CODES/STANDARDS USA

**WINNEBAGO** COPYRIGHT 2014 WINNEBAGO INDUSTRIES, INC.

ALL DIMENSIONS ARE IN MILLIMETERS

15 727D

UNSPECIFIED TOLERANCES ARE:  
 WHOLE DIM (X) : 3  
 ONE-PLACE (X.X) : 1.5  
 TWO-PLACE (X.XX) : 0.50  
 ANGLE : 1'

THIRD ANGLE PROJECTION

DO NOT SCALE DRAWING REFER TO ES0018 FOR FASTENER TIGHTENING GUIDELINES

TITLE: **WIRING INSTL-CHASSIS**

SHEET 1 OF 3 PART NO **190063** REV

REF: 1 26-Sep-2014

- 6 WIRES PASS THROUGH FLOOR IN THIS AREA.
- 5 COIL EXCESS CAMERA CABLE HERE FOR TRANSPORTATION PURPOSES.
- 4 ROUTE WITH WIRE ASM-CHASSIS.
- 3 CUT WIRE AND RECONNECT AS SHOWN.
2. SECURE WIRE ASM AND CABLES WITH WIRE TIE 8343-01-000 OR 116673-01-000 AT NO MORE THAN 600MM CENTER ALONG ENTIRE ROUTED PATH.
1. SECURE CONDUIT 41953, TAB AS REQUIRED, OVER ALL WIRES IN CONTACT WITH SHARP EDGES.

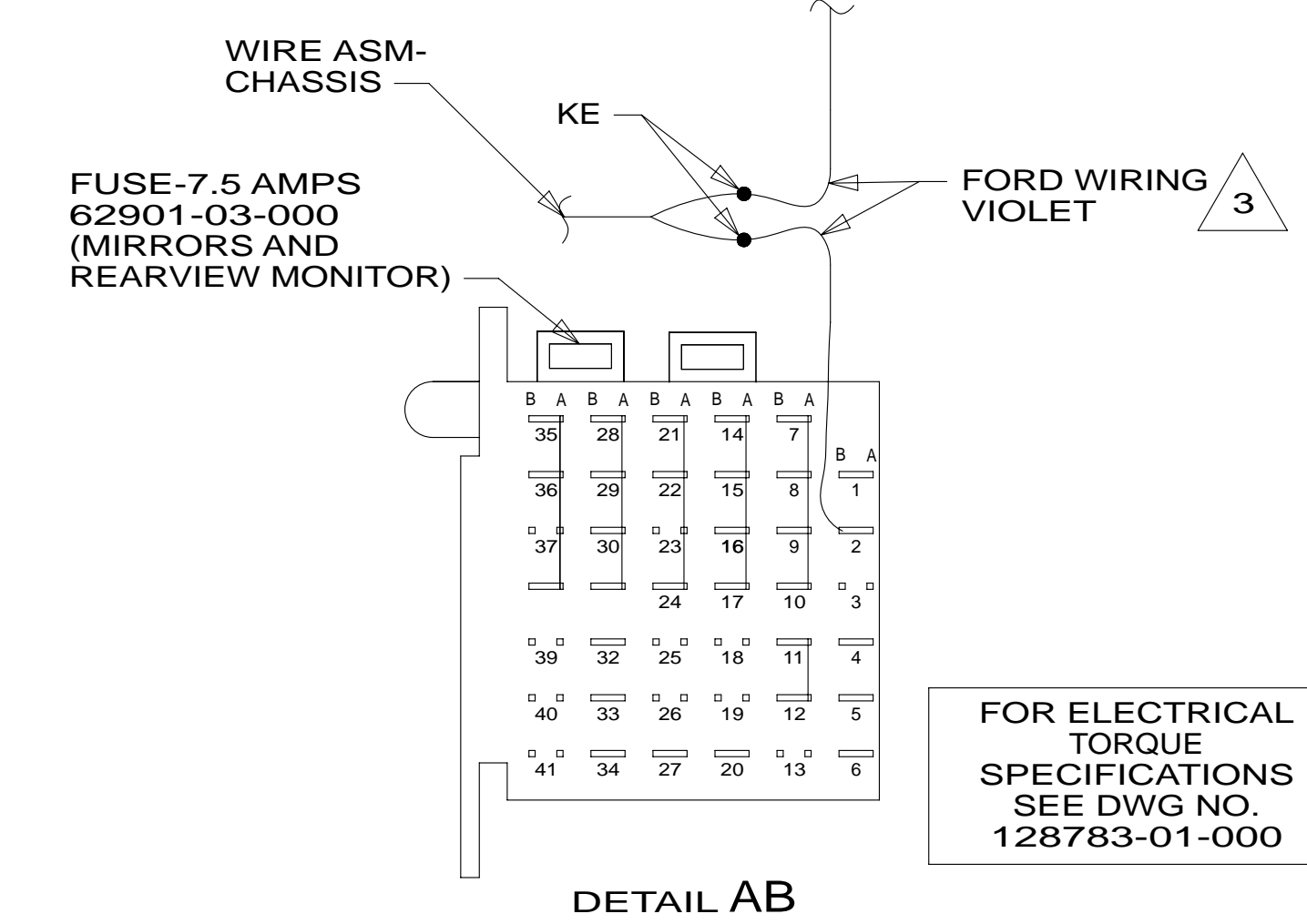

FOR ELECTRICAL TORQUE SPECIFICATIONS SEE DWG NO. 128783-01-000

FOR ELECTRICAL CALLOUTS SEE DWG NO. 121339-01-000

\* 190063 \*

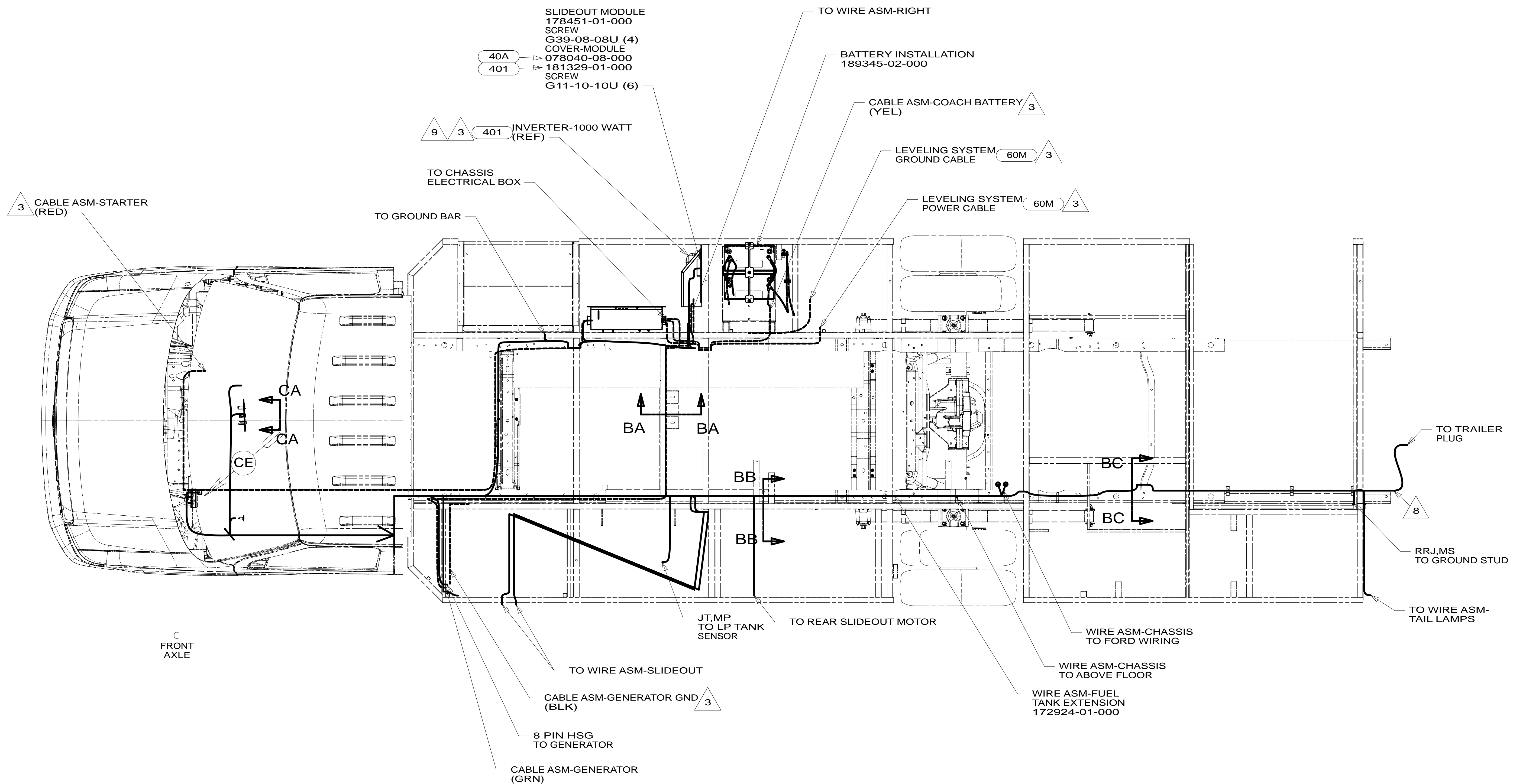

- 9 SEE LOAD CENTER/ATS ASM FOR ADDITIONAL INFORMATION.
- 8 COIL UP EXCESS MONITOR CABLE HERE.
- 7 WIRES TO BE TIED TO TOP OF RAIL USING EXISTING HOLES.
- 6 CUT OFF EXCESS END OF WIRE TIE.
- 5 WIRES TO BE TIED TO INSIDE OF RAIL USING EXISTING HOLES.
- 4 WIRES TO BE TIED TO CROSS MEMBER USING EXISTING HOLES.
- 3 SEE BATTERY INSTALLATION FOR ADDITIONAL INFORMATION.

2. SECURE WIRE ASM AND CABLES WITH WIRE TIE 8343-01-000 OR 116673-01-000 AT NO MORE THAN 600MM CENTER ALONG ENTIRE ROUTED PATH.
1. SECURE CONDUIT 41953, TAB AS REQUIRED, OVER ALL WIRES IN CONTACT WITH SHARP EDGES.

NOTES:

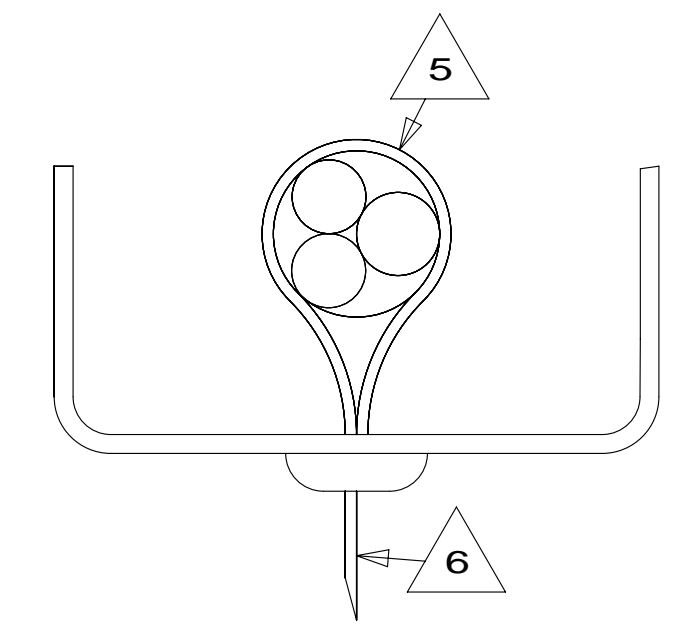
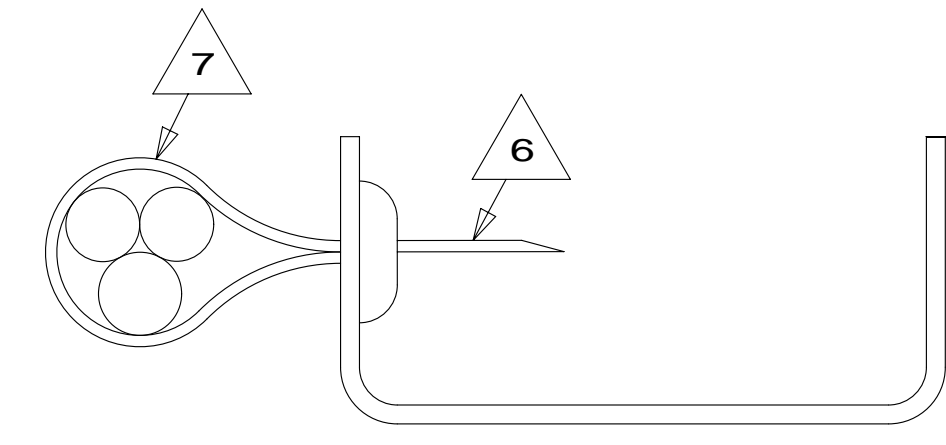
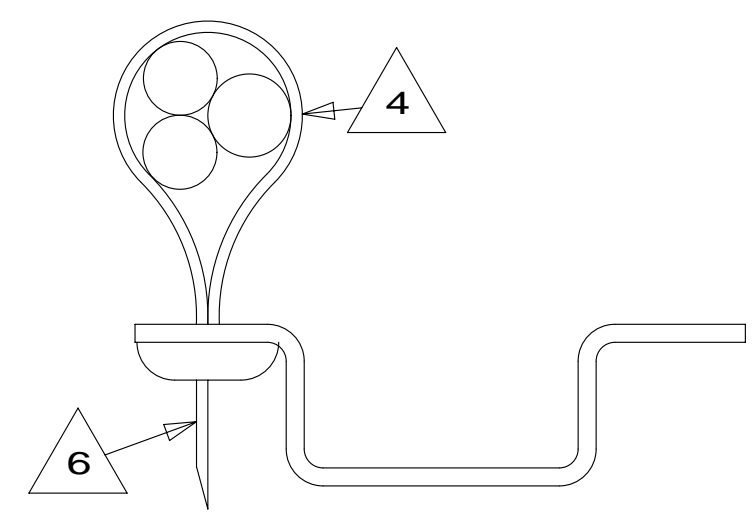

- 40A INVERTER-DC/AC WITHOUT
- 401 INVERTER-DC/AC, 1000 WATT
- 60M HYDRAULIC LEVEL JACKS-AUTO
- 16Y FORD CHASSIS - 14,500#\_GVWR
- 265 CODES/STANDARDS-CSA/CMVSS
- 1B1 CODES/STANDARDS USA

1B1 265 16Y

FIRST USED	<b>15 727D</b>	
<b>DO NOT SCALE DRAWING</b>		
<b>TITLE: WIRING INSTL-CHASSIS</b>		
SHEET 2	PART NO <b>190063</b>	REV

FOR ELECTRICAL TORQUE SPECIFICATIONS SEE DWG NO. 128783-01-000

FOR ELECTRICAL CALLOUTS SEE DWG NO. 121339-01-000

\* 190063

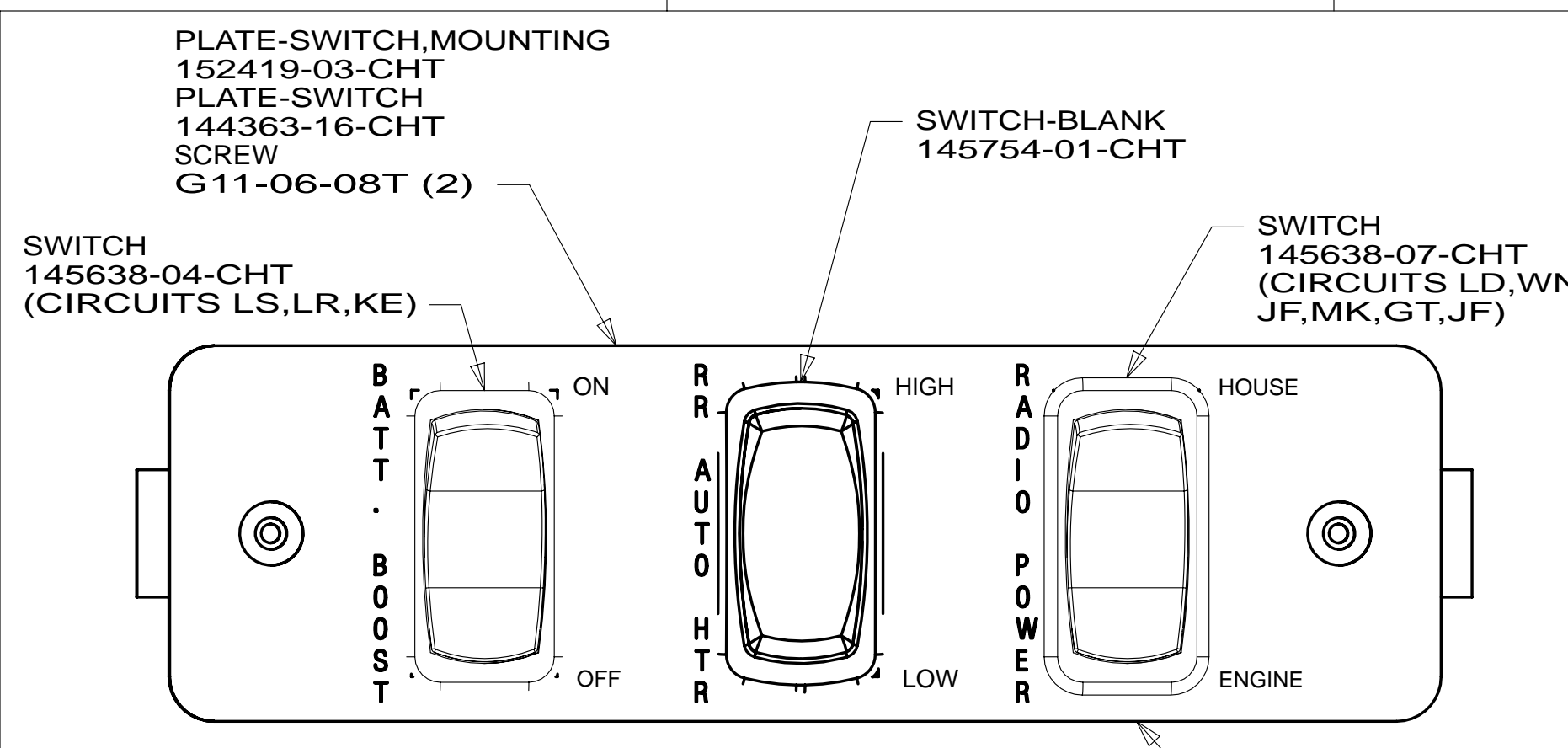

DETAIL CA

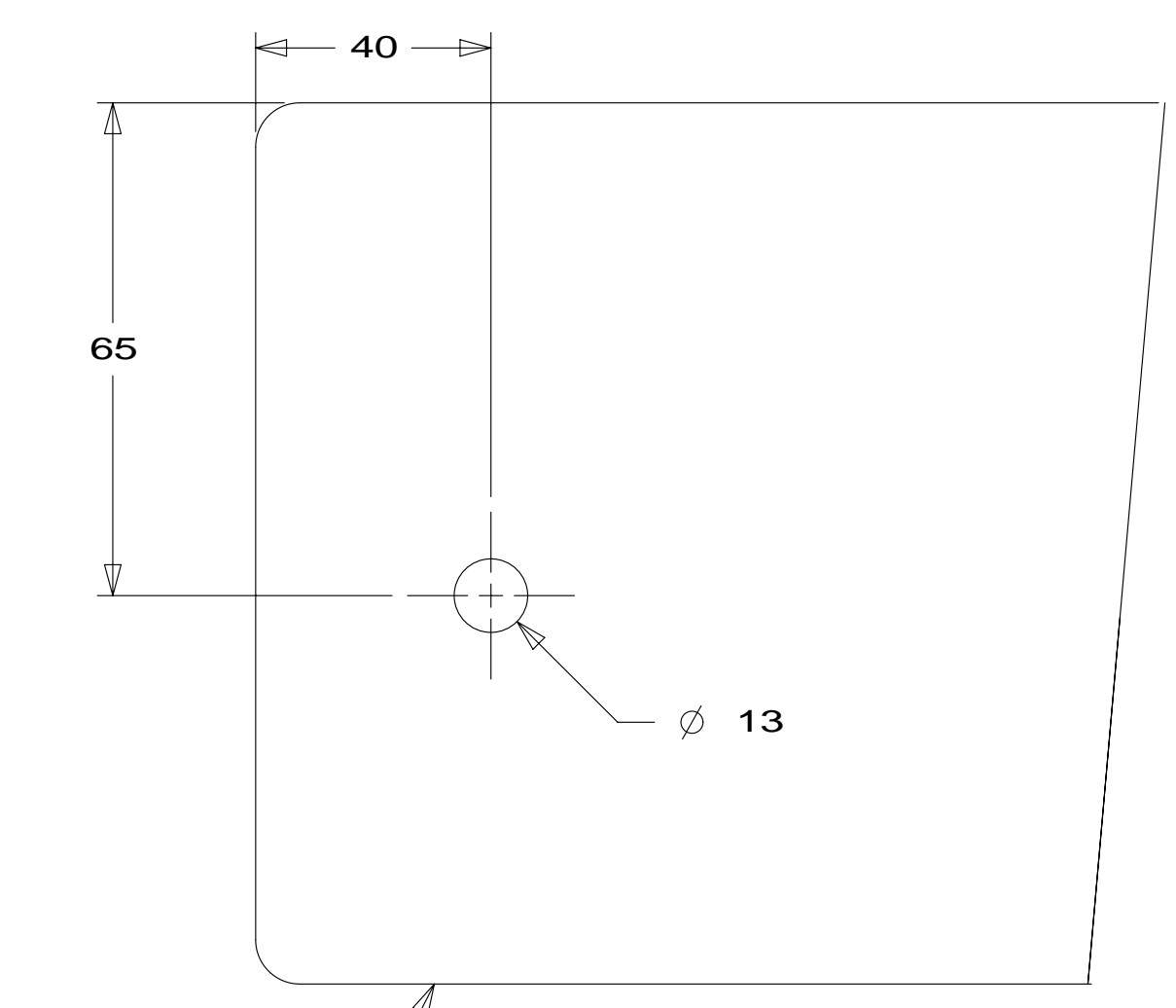

DETAIL CD

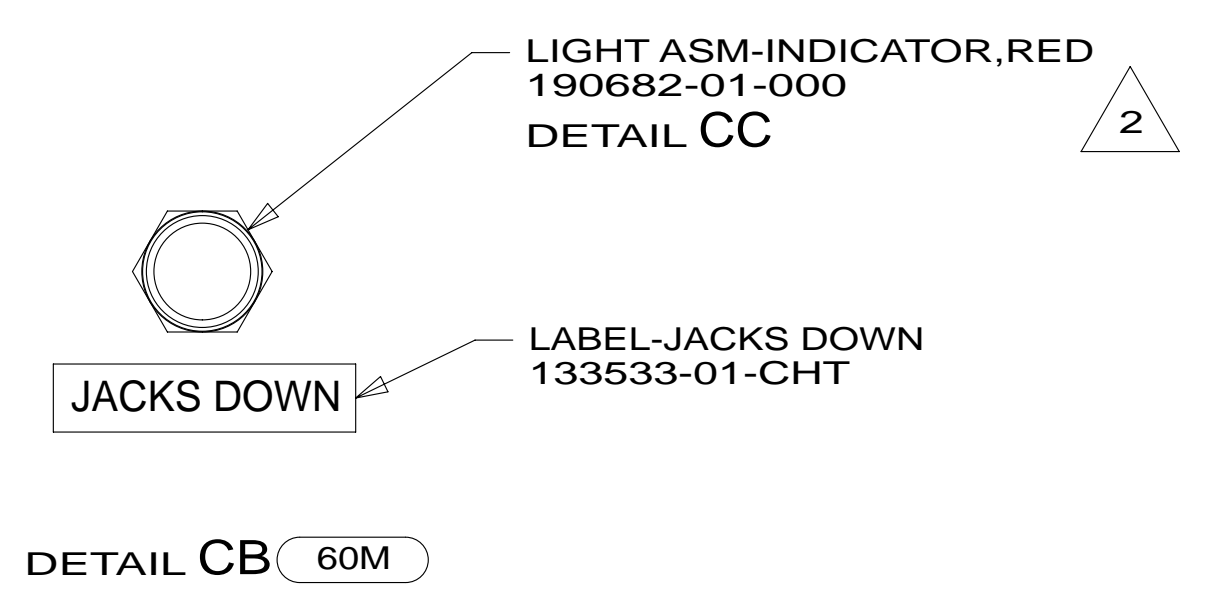

DETAIL CB

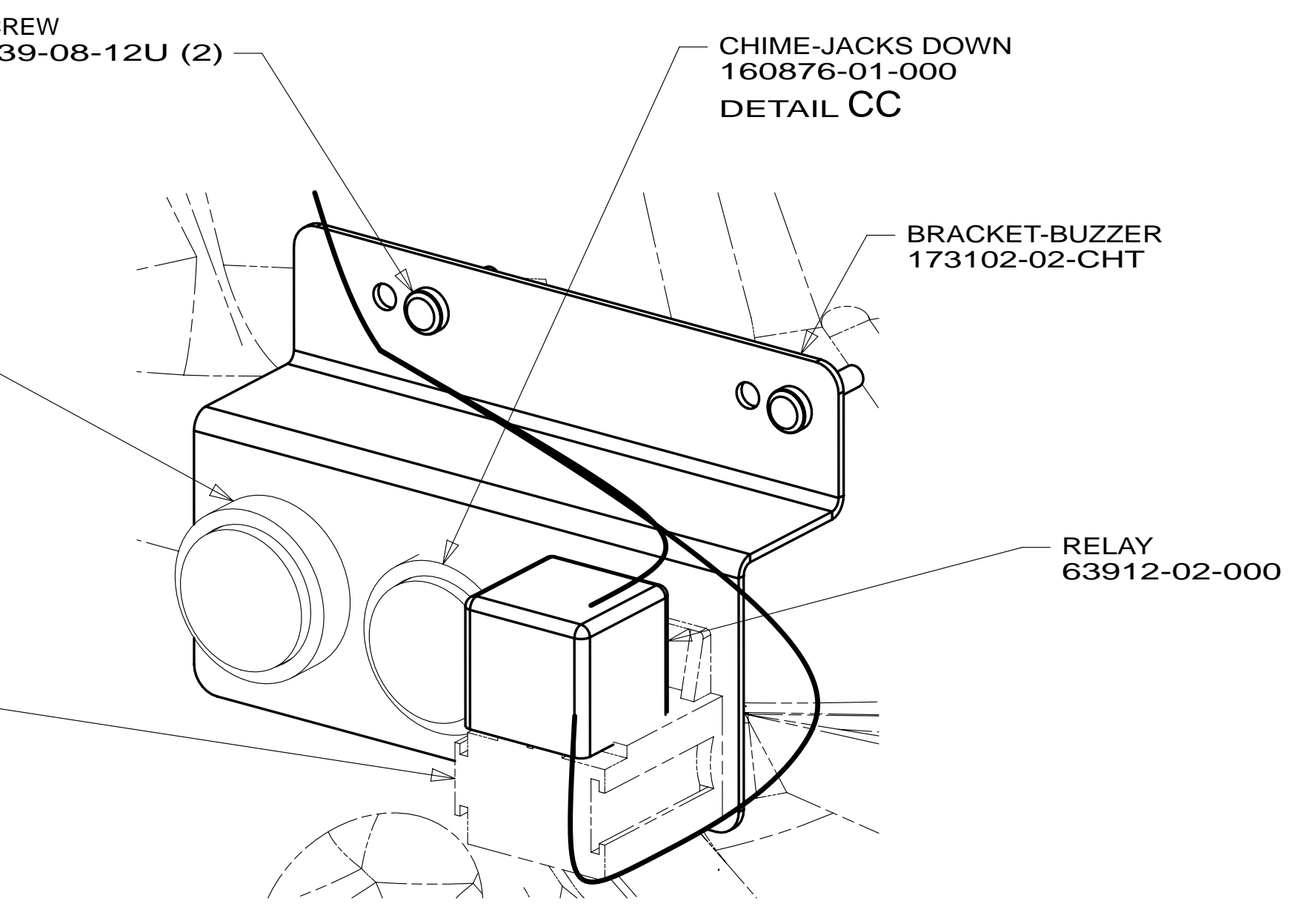

DETAIL CE

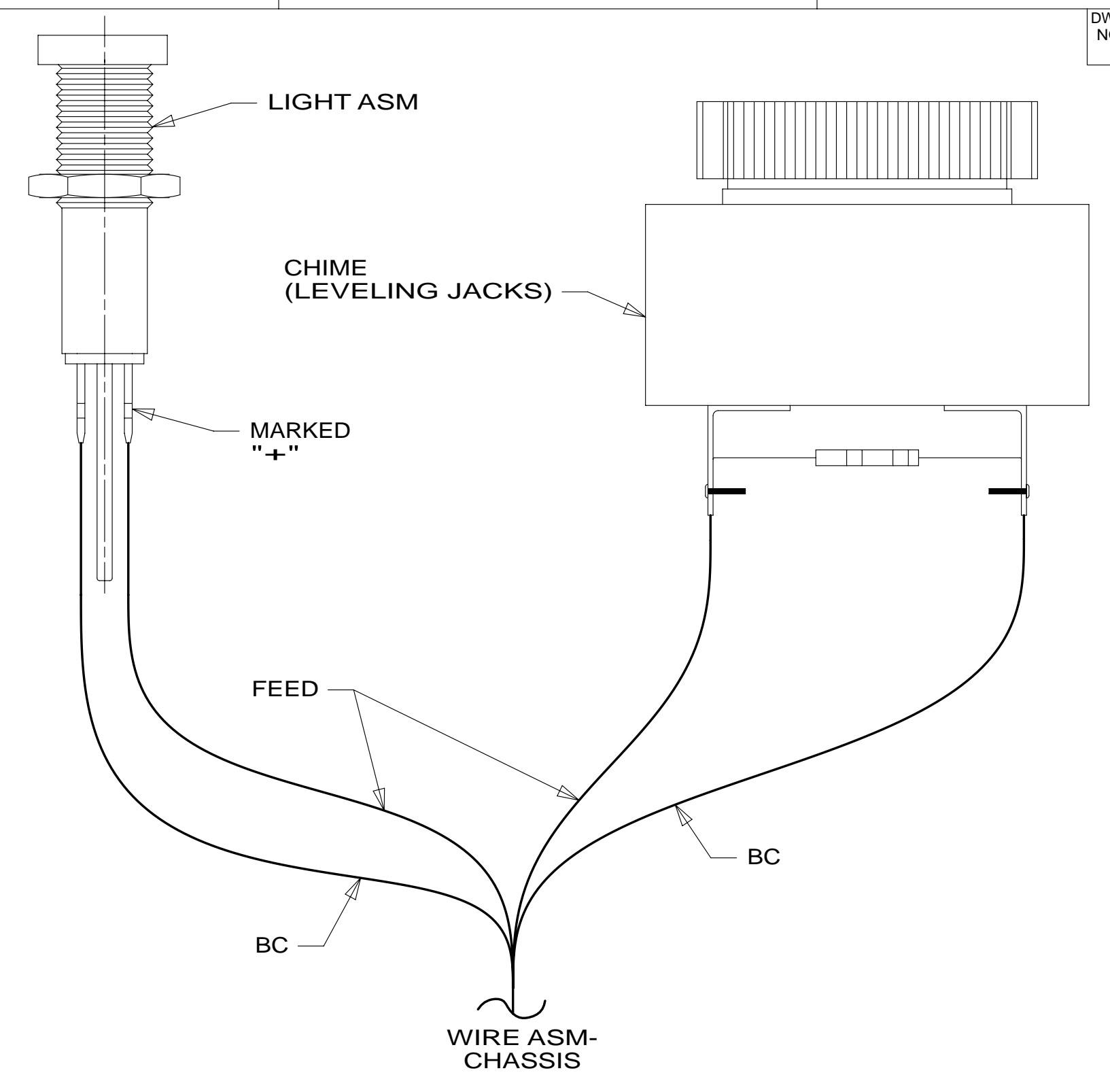

DETAIL CC

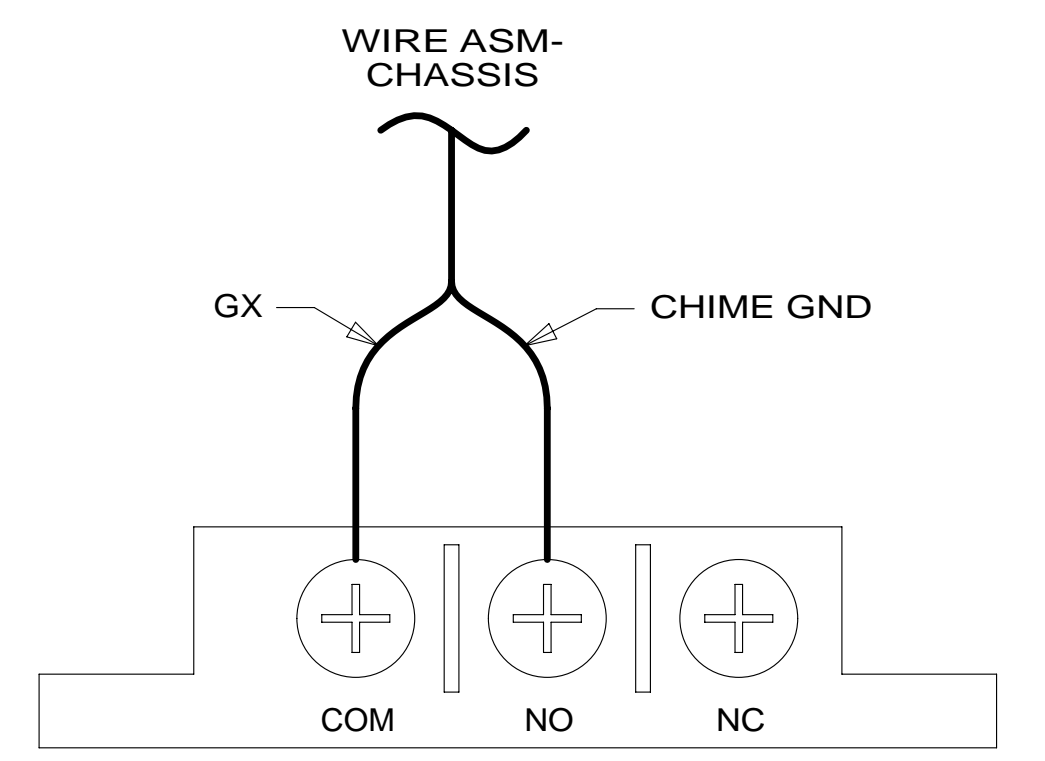

DETAIL CH

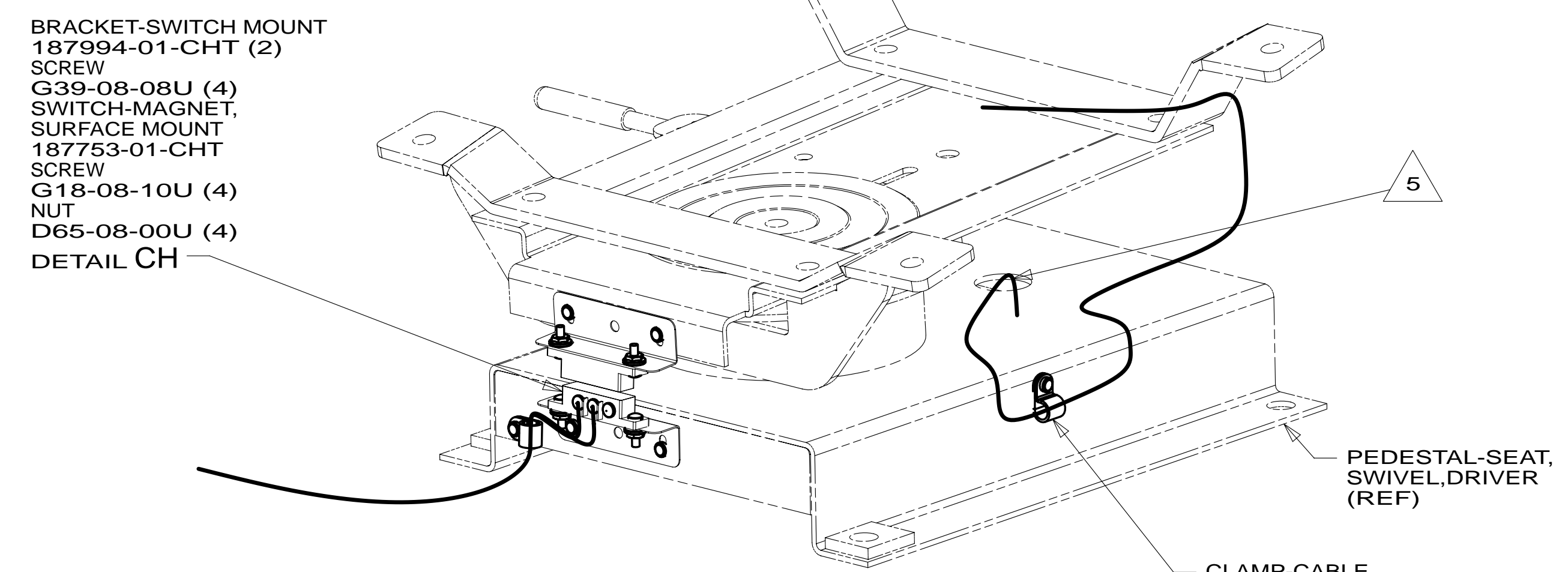

DETAIL CF

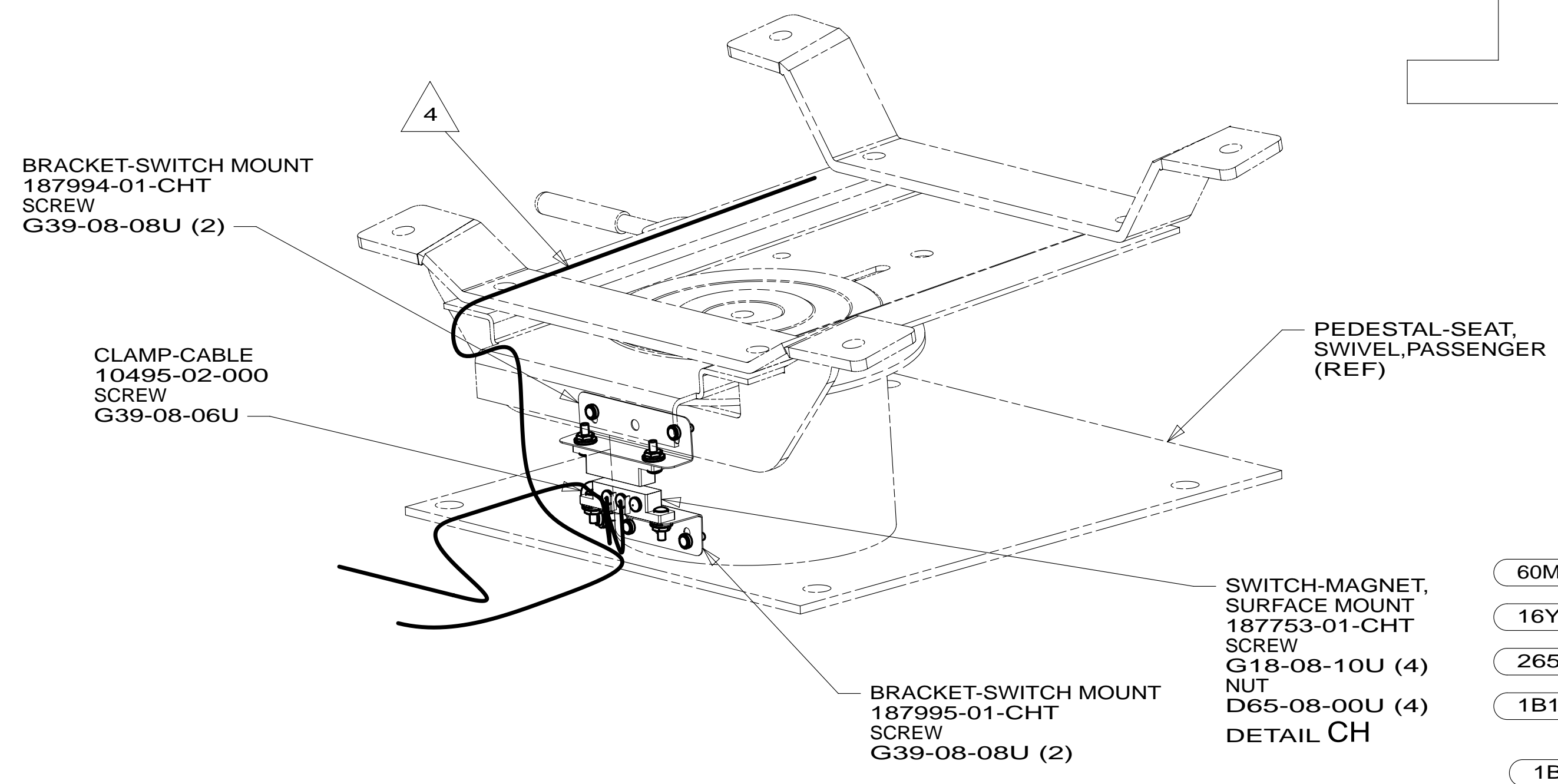

DETAIL CG

- NOTES:
- 3 INSTALL CLAMP FOR FORD SEAT WIRING.
  - 2 FOR HOLE SIZE AND LOCATION SEE DETAIL CD.
  - 1 PART OF WIRE ASM-CHASSIS.
  - 5 COVER WIRING WITH CONVOLUTE 41953-01-000 (150 MM) TO PROTECT WIRES FROM SHARP EDGES WHERE THEY PASS THROUGH SEAT PEDESTAL. SECURE BOTH ENDS TO WIRES WITH TAPE 8363-01-000.
  - 4 ATTACH WIRE TIE 116673-01-000 TO FORD SEAT WIRING.

- 60M HYDRAULIC LEVEL JACKS-AUTO
- 16Y FORD CHASSIS - 14,500#\_GVVWR
- 265 CODES/STANDARDS-CSA/CMVSS
- 1B1 CODES/STANDARDS USA

FOR ELECTRICAL TORQUE SPECIFICATIONS SEE DWG NO. 128783-01-000

FOR ELECTRICAL CALLOUTS SEE DWG NO. 121339-01-000

FIRST USED

**15 727D**

DO NOT SCALE DRAWING

TITLE: **WIRING INSTL-CHASSIS**

SHEET 3 PART NO **190063** REV

26-Sep-2014

\* 190063