



DANGER

Danger of electrical shock, burns or death. Always remove all power sources before attempting any repair, service or diagnostic work. Power can be present from shore power, generator, inverter or battery. All power sources must be disabled and secured before performing any service.



CAUTION

If you lack the skills, tools or equipment to perform diagnostic or repair work leave such work to an authorized Winnebago Industries dealer or other qualified shop.

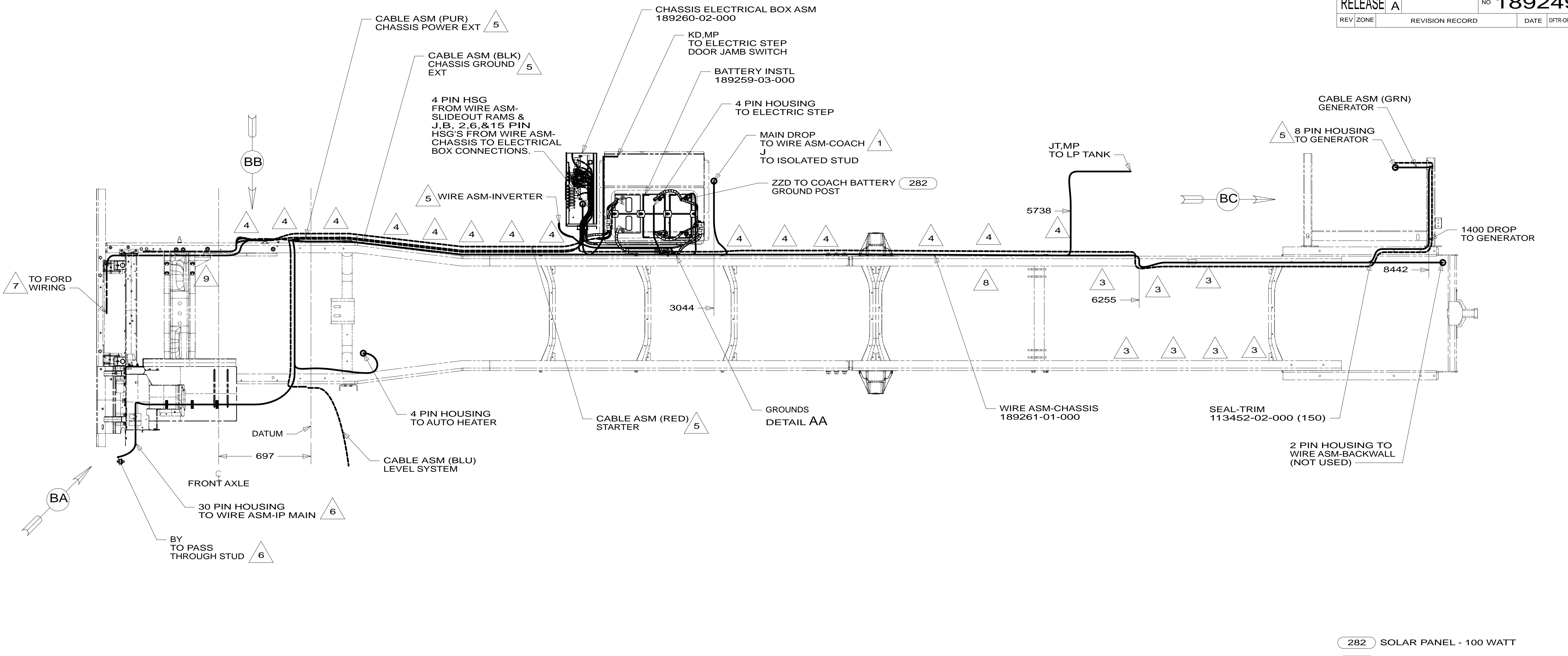

- 8 SECURE SO WIRES DO NOT CONTACT EXHAUST.
 - 7 SUPPLIED WITH CHASSIS.
 - 6 SEE WIRING INSTL-FRONT END FOR ADDITIONAL INFORMATION.
 - 5 SEE BATTERY INSTL FOR ADDITIONAL INFORMATION.
 - 4 CLAMP 83610-03-000, SCREW G39-08-12U.
 - 3 CLAMP 83610-01-000, SCREW G39-08-12U.
 - 2. SECURE CONDUIT 41953-09, -10, -11, -13, AND -14 OVER ALL WIRES IN CONTACT WITH SHARP EDGES.
 - 1 SEE WIRING INSTL-BODY, 12V FOR ADDITIONAL INFORMATION.
- NOTES:

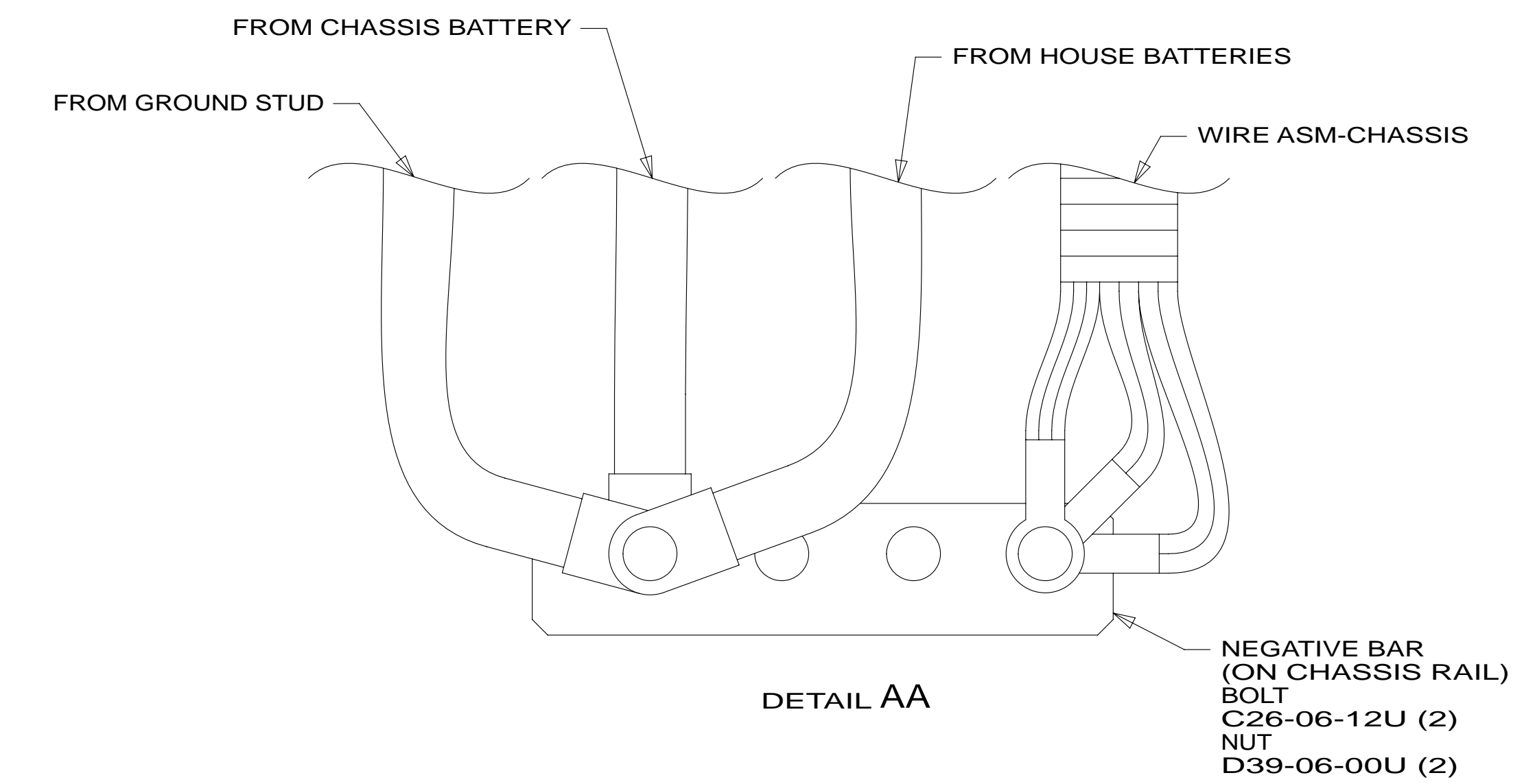

282 SOLAR PANEL - 100 WATT
 16Z FORD 24,000#-22.5 ALUM WHEEL
 16L FORD 22,000#-22.5 AL WHL
 265 CODES/STANDARDS-CSA/CMVSS
 1B1 CODES/STANDARDS USA

1B1 265 16L 16Z

WINNEBAGO
 COPYRIGHT 2014 WINNEBAGO INDUSTRIES, INC.

DFTR	ORIG. DATE
CHKR	ALL DIMENSIONS ARE IN MILLIMETERS
P.E.	
M.E.	FIRST USED
DSNR	15 J35P

UNSPECIFIED TOLERANCES ARE:
 WHOLE DIM (X) : 3
 ONE-PLACE (X.X) : 1.5
 TWO-PLACE (X.XX) : 0.50
 ANGLE : 1°

THIRD ANGLE PROJECTION

DO NOT SCALE DRAWING REFER TO ES0018 FOR FASTENER TIGHTENING GUIDELINES

TITLE: **WIRING INSTL-CHASSIS**

SHEET 1 OF 2 PART NO **189249** REV

REF: 1 26-Feb-2014

FOR ELECTRICAL TORQUE SPECIFICATIONS SEE DWG NO. 128783-01-000

X-X FOR ELECTRICAL CALLOUTS SEE DWG NO. 121339-01-000

* 189249 *

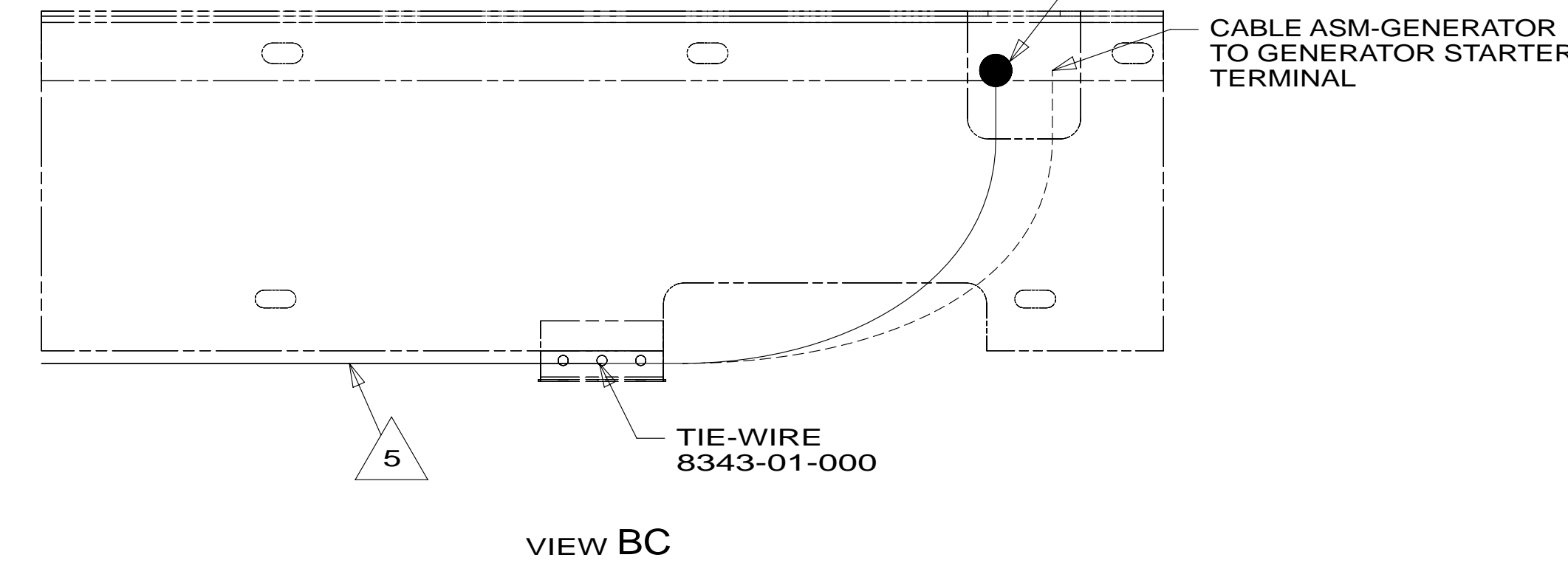
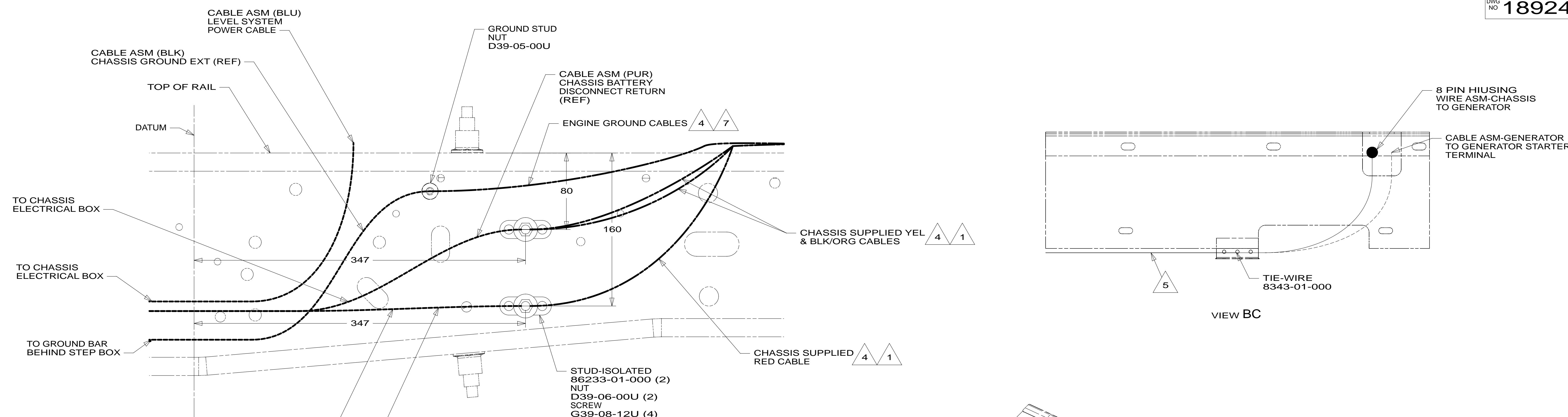

VIEW BB

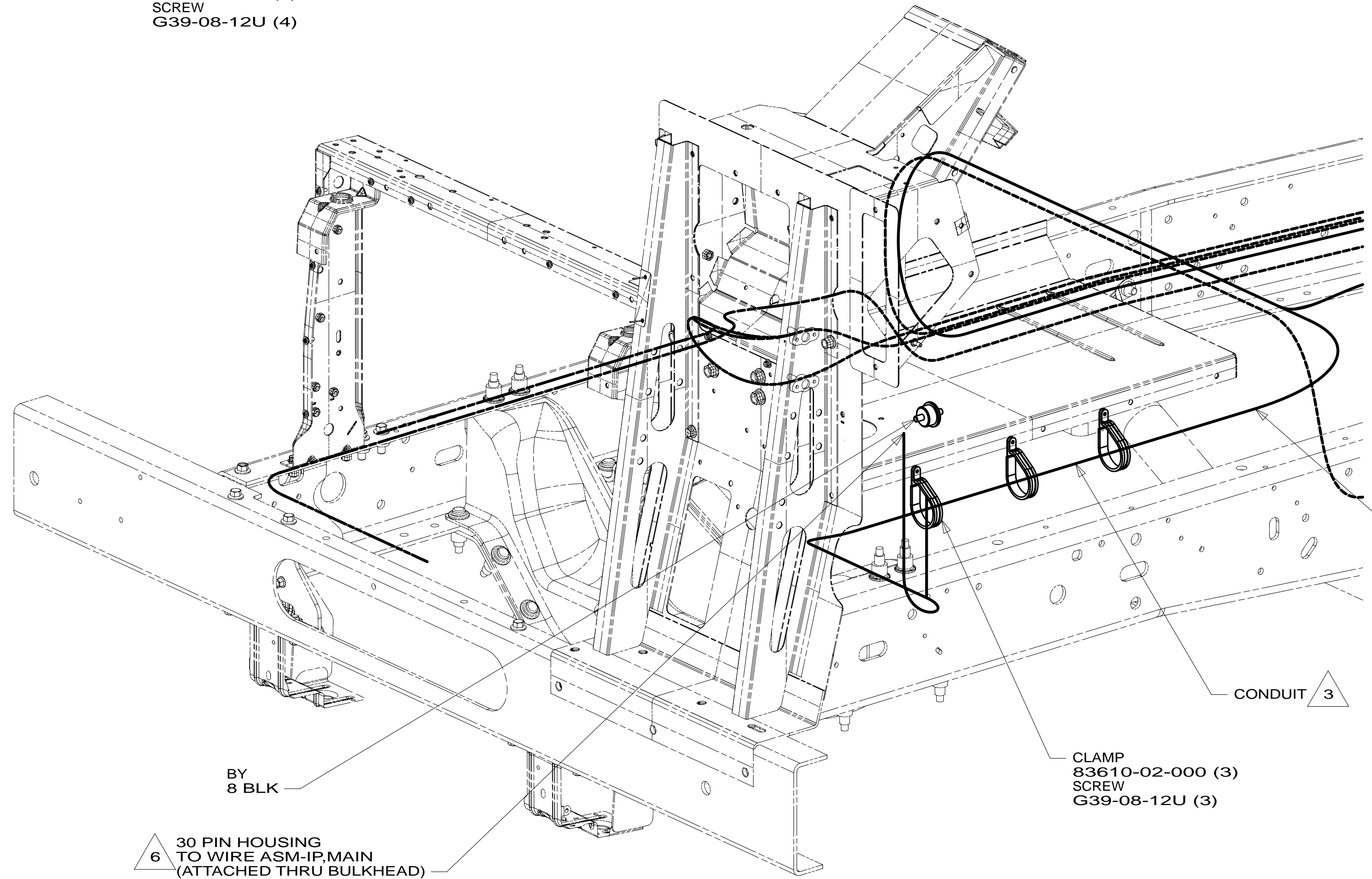

VIEW BA

- NOTES:
- 7 CUT CHASSIS SUPPLIED BATTERY CABLE 700MM FROM BATTERY TERMINAL AND ADD TERMINAL 8348-01-000 TO CUT END
 - 6 SEE WIRING INSTL-FRONT END FOR ADDITIONAL INFORMATION.
 - 5 SECURE SO WIRES DO NOT CONTACT EXHAUST.
 - 4 SUPPLIED WITH CHASSIS.
 - 3 COVER WITH CONDUIT 41953-10-000 AND 41953-11-000 AS REQUIRED.
 - 2. SECURE CONDUIT 41953-09, -10, -11, -13, AND -14 OVER ALL WIRES IN CONTACT WITH SHARP EDGES.
 - 1 CUT CHASSIS SUPPLIED POSITIVE BATTERY CABLE 150MM FROM BATTERY TERMINAL END, DISCARD TERMINAL END AND SEPARATE WIRES. ADD TERMINAL 8348-01-000 AND HEAT SHRINK 176567-04-000 TO RED CABLE (CHASSIS STARTER) AND COMBINE YELLOW (CHASSIS POWER DISTRIBUTION) AND BLACK/ORANGE (CHASSIS ALTERNATOR) WIRES TOGETHER AND ADD TERMINAL 8348-01-000 AND HEAT SHRINK 176567-02-000. COIL EXCESS CABLE ALONG FRAME RAIL JUST BEHIND RADIATOR AND TIE UP WITH TIE-WIRE 8343-04-000.

- 16Z FORD 24,000#-22.5 ALUM WHEEL
- 16L FORD 22,000#-22.5 AL WHL
- 265 CODES/STANDARDS-CSA/CMVSS
- 1B1 CODES/STANDARDS USA

1B1	265	16L	16Z
FIRST USED			
15 J35P			
DO NOT SCALE DRAWING			
TITLE: WIRING INSTL-CHASSIS			
SHEET 2	PART NO	189249	REV

FOR ELECTRICAL TORQUE SPECIFICATIONS SEE DWG NO. 128783-01-000

FOR ELECTRICAL CALLOUTS SEE DWG NO. 121339-01-000

* 189249 * A