



DANGER

Danger of electrical shock, burns or death. Always remove all power sources before attempting any repair, service or diagnostic work. Power can be present from shore power, generator, inverter or battery. All power sources must be disabled and secured before performing any service.



CAUTION

If you lack the skills, tools or equipment to perform diagnostic or repair work leave such work to an authorized Winnebago Industries dealer or other qualified shop.

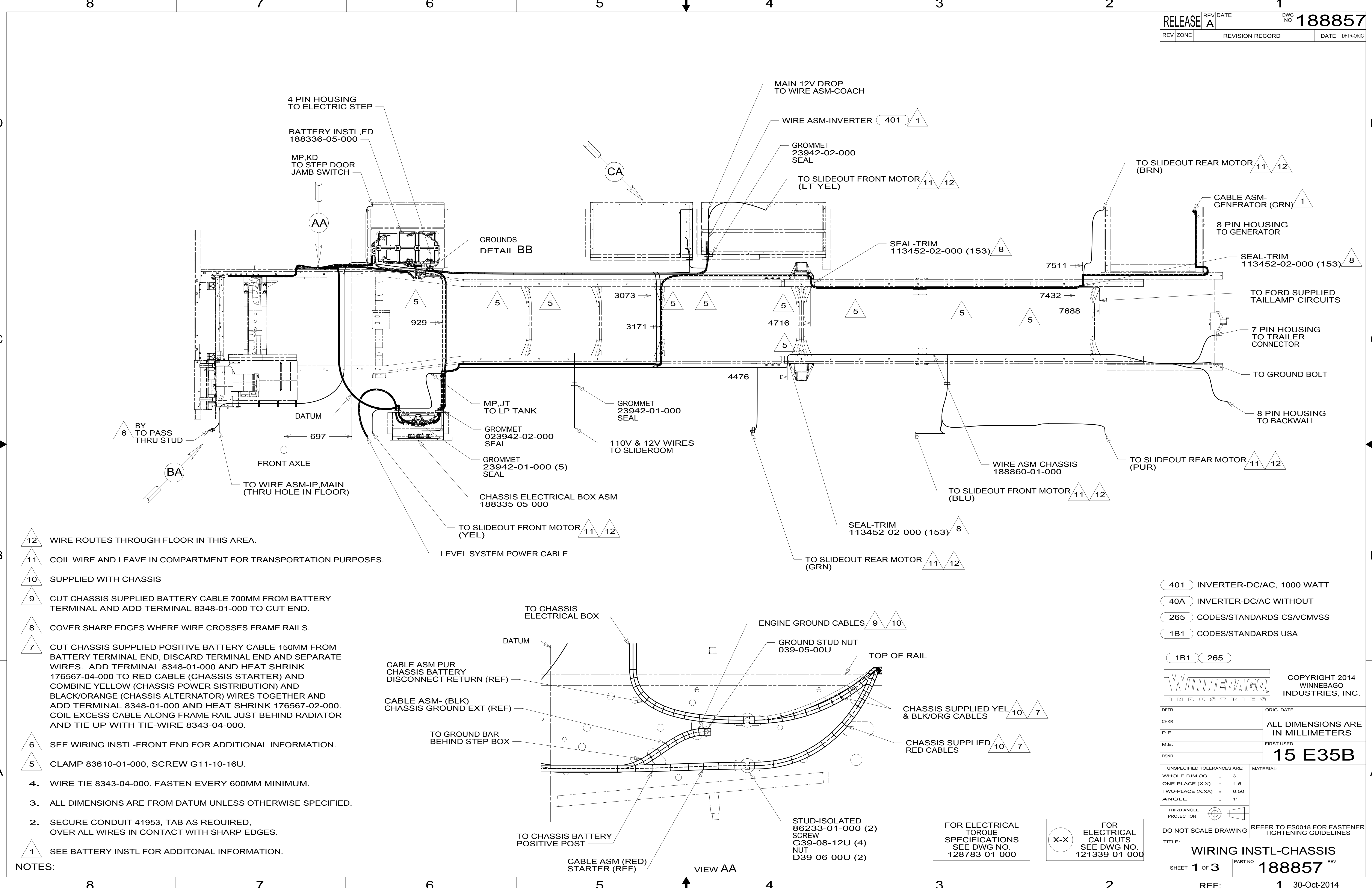

- 12 WIRE ROUTES THROUGH FLOOR IN THIS AREA.
- 11 COIL WIRE AND LEAVE IN COMPARTMENT FOR TRANSPORTATION PURPOSES.
- 10 SUPPLIED WITH CHASSIS
- 9 CUT CHASSIS SUPPLIED BATTERY CABLE 700MM FROM BATTERY TERMINAL AND ADD TERMINAL 8348-01-000 TO CUT END.
- 8 COVER SHARP EDGES WHERE WIRE CROSSES FRAME RAILS.
- 7 CUT CHASSIS SUPPLIED POSITIVE BATTERY CABLE 150MM FROM BATTERY TERMINAL END, DISCARD TERMINAL END AND SEPARATE WIRES. ADD TERMINAL 8348-01-000 AND HEAT SHRINK 176567-04-000 TO RED CABLE (CHASSIS STARTER) AND COMBINE YELLOW (CHASSIS POWER DISTRIBUTION) AND BLACK/ORANGE (CHASSIS ALTERNATOR) WIRES TOGETHER AND ADD TERMINAL 8348-01-000 AND HEAT SHRINK 176567-02-000. COIL EXCESS CABLE ALONG FRAME RAIL JUST BEHIND RADIATOR AND TIE UP WITH TIE-WIRE 8343-04-000.
- 6 SEE WIRING INSTL-FRONT END FOR ADDITIONAL INFORMATION.
- 5 CLAMP 83610-01-000, SCREW G11-10-16U.
- 4. WIRE TIE 8343-04-000. FASTEN EVERY 600MM MINIMUM.
- 3. ALL DIMENSIONS ARE FROM DATUM UNLESS OTHERWISE SPECIFIED.
- 2. SECURE CONDUIT 41953, TAB AS REQUIRED, OVER ALL WIRES IN CONTACT WITH SHARP EDGES.
- 1 SEE BATTERY INSTL FOR ADDITIONAL INFORMATION.

- 401 INVERTER-DC/AC, 1000 WATT
- 40A INVERTER-DC/AC WITHOUT
- 265 CODES/STANDARDS-CSA/CMVSS
- 1B1 CODES/STANDARDS USA

WINNEBAGO COPYRIGHT 2014 WINNEBAGO INDUSTRIES, INC.

DFTR	ORIG. DATE
CHKR	ALL DIMENSIONS ARE IN MILLIMETERS
P.E.	FIRST USED
M.E.	15 E35B
DSNR	MATERIAL:
UNSPECIFIED TOLERANCES ARE:	
WHOLE DIM (X)	: 3
ONE-PLACE (X.X)	: 1.5
TWO-PLACE (X.XX)	: 0.50
ANGLE	: 1°
THIRD ANGLE PROJECTION	
DO NOT SCALE DRAWING	REFER TO ES0018 FOR FASTENER TIGHTENING GUIDELINES
TITLE: WIRING INSTL-CHASSIS	
SHEET 1 OF 3	PART NO 188857 REV
REF:	1 30-Oct-2014

FOR ELECTRICAL TORQUE SPECIFICATIONS SEE DWG NO. 128783-01-000

X-X FOR ELECTRICAL CALLOUTS SEE DWG NO. 121339-01-000

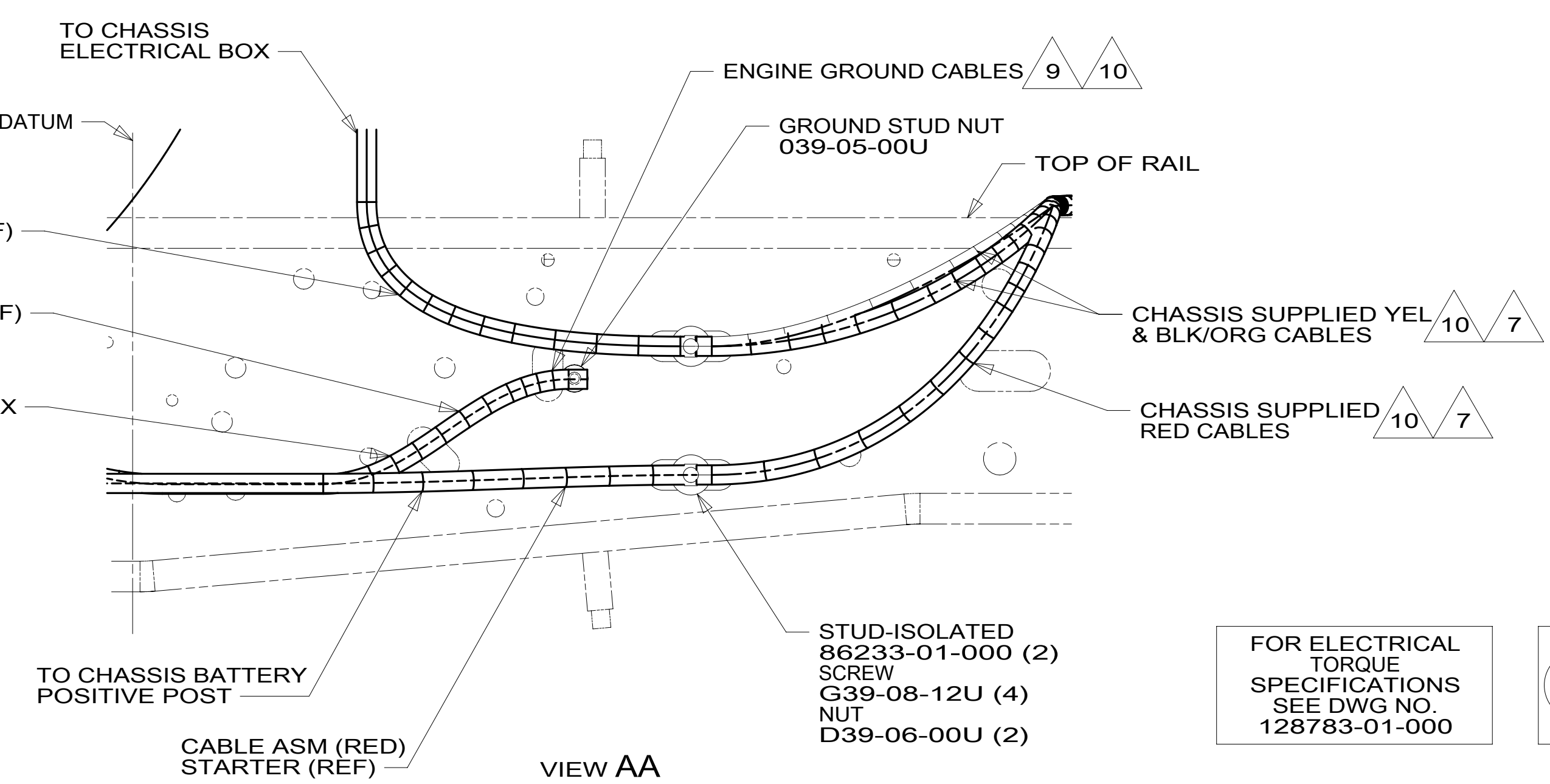

188857

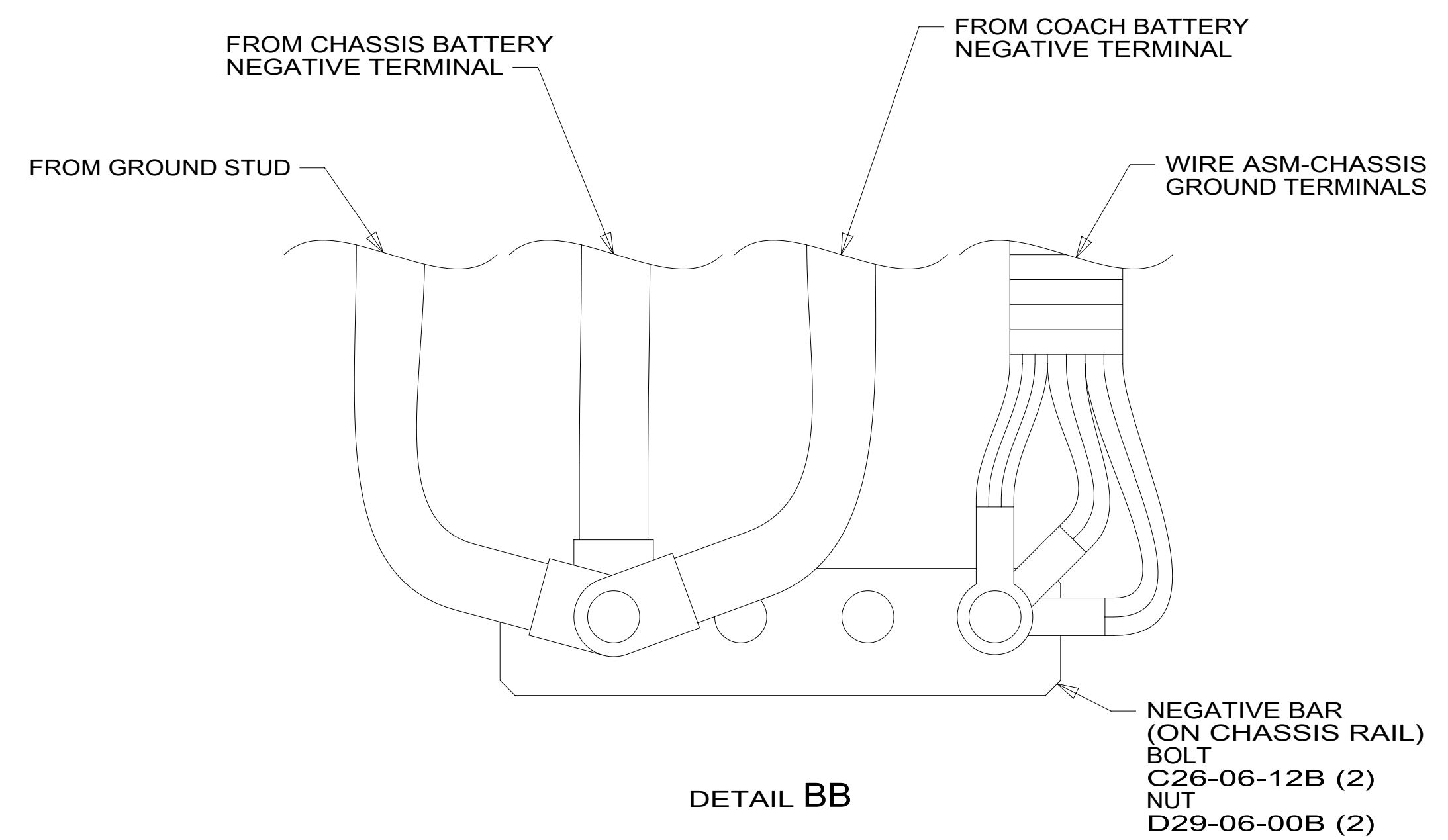
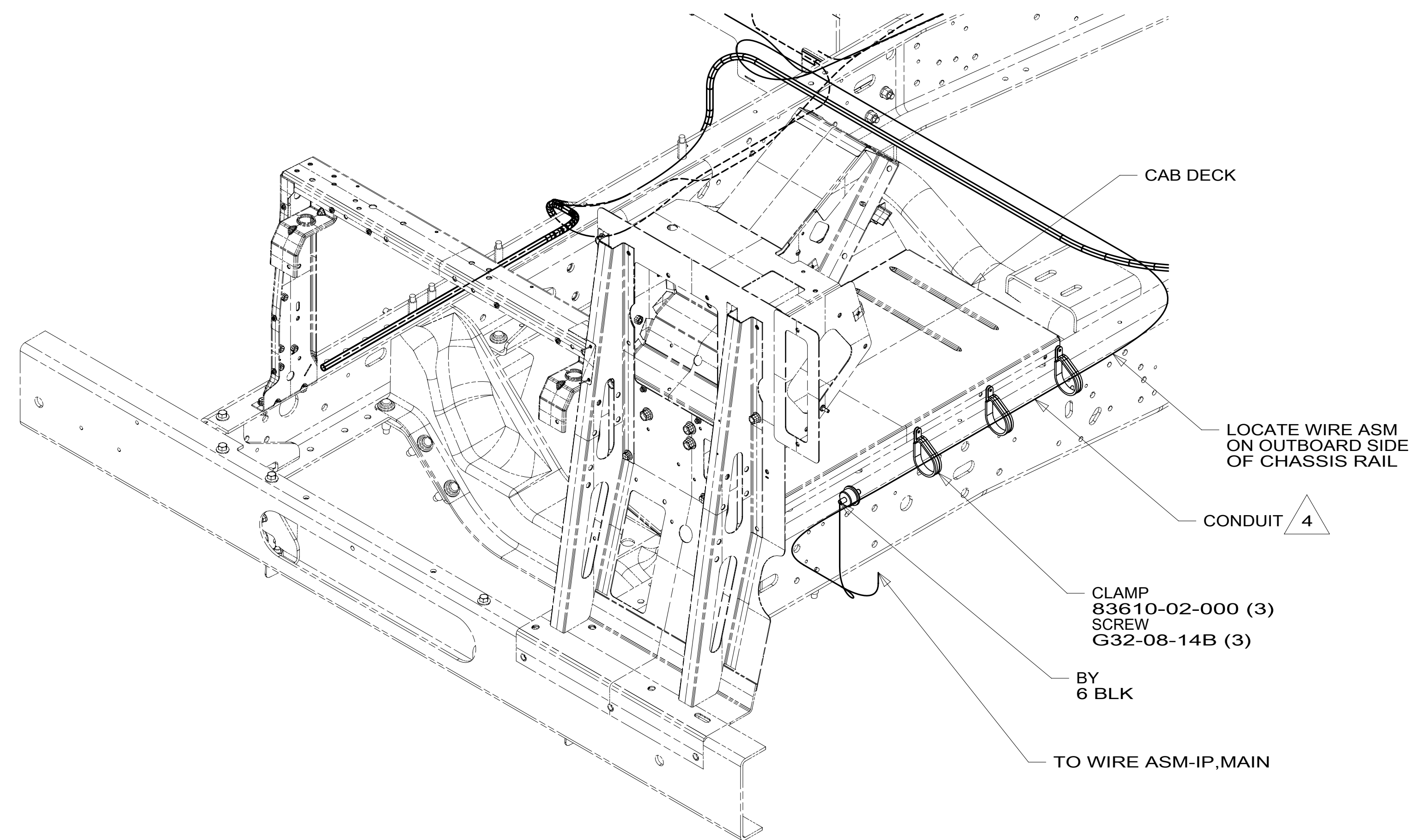

VIEW BA

4 COVER WITH CONDUIT 41953-10-000 AND 41953-11-000 AS REQUIRED.

3. CONNECT CABLES TO COACH SIDE OF BATTERY DISCONNECT WHEN BATTERY DISCONNECT IS USED.

2. ALL GROUND WIRE TO BE COVERED WITH TUBING 8041-02-000.

1. CUT OFF EXCESS END OF WIRE TIE.

NOTES:

FOR ELECTRICAL TORQUE SPECIFICATIONS SEE DWG NO. 128783-01-000

FOR ELECTRICAL CALLOUTS SEE DWG NO. 121339-01-000

265 CODES/STANDARDS-CSA/CMVSS

1B1 CODES/STANDARDS USA

1B1 265

FIRST USED **15 E35B**

DO NOT SCALE DRAWING

TITLE: **WIRING INSTL-CHASSIS**

SHEET 2 PART NO **188857** REV

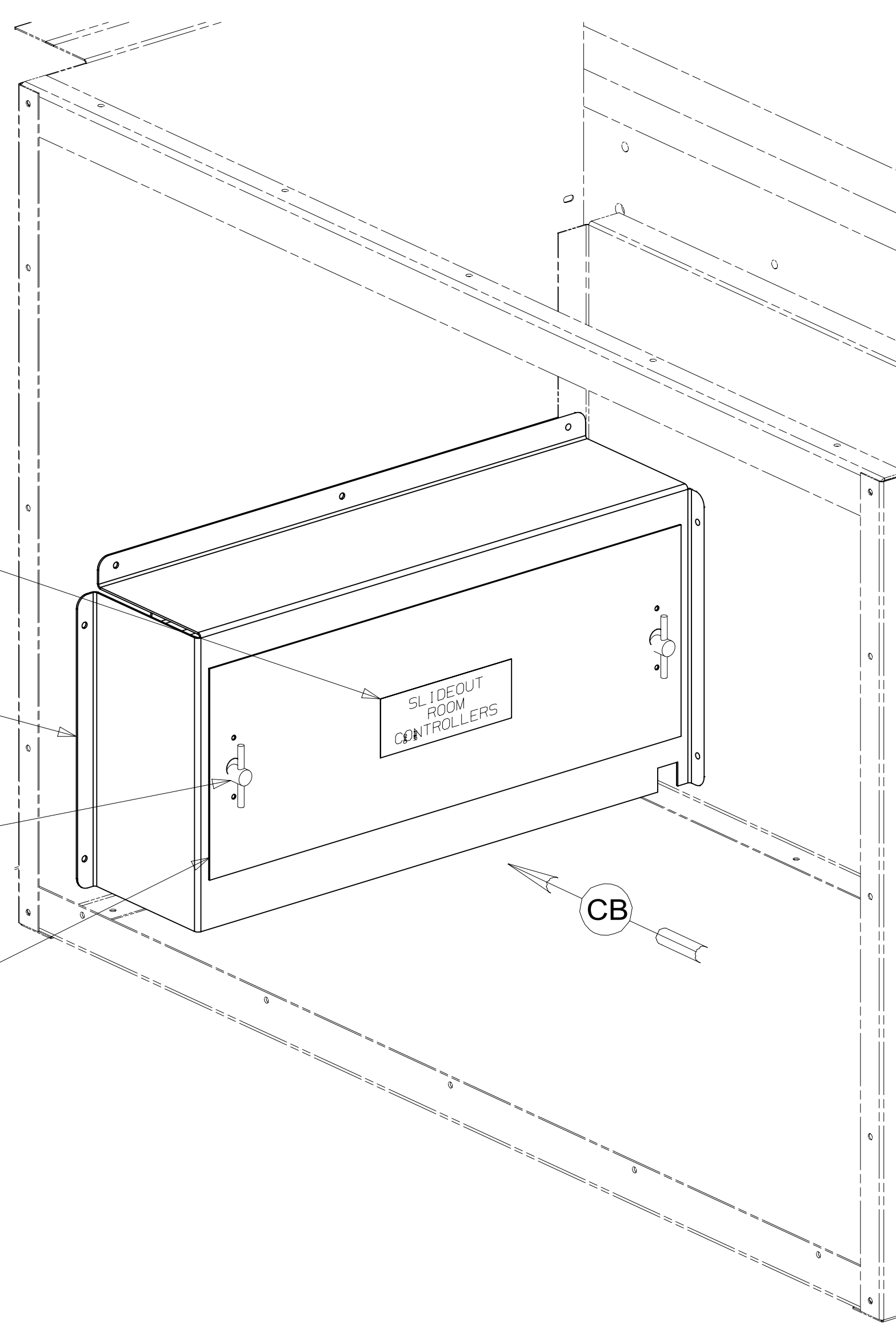

- LABEL 98379-09-000
- PANEL-COMPARTMENT 170153-04-CHT SCREW G39-08-08U (6)
- LATCH 98196-01-000 (2) RIVET H15-04-02R (4)
- DOOR ASM-ELECTRICAL BOX 142145-01-CHT SEAL 92492-11-000

VIEW CA

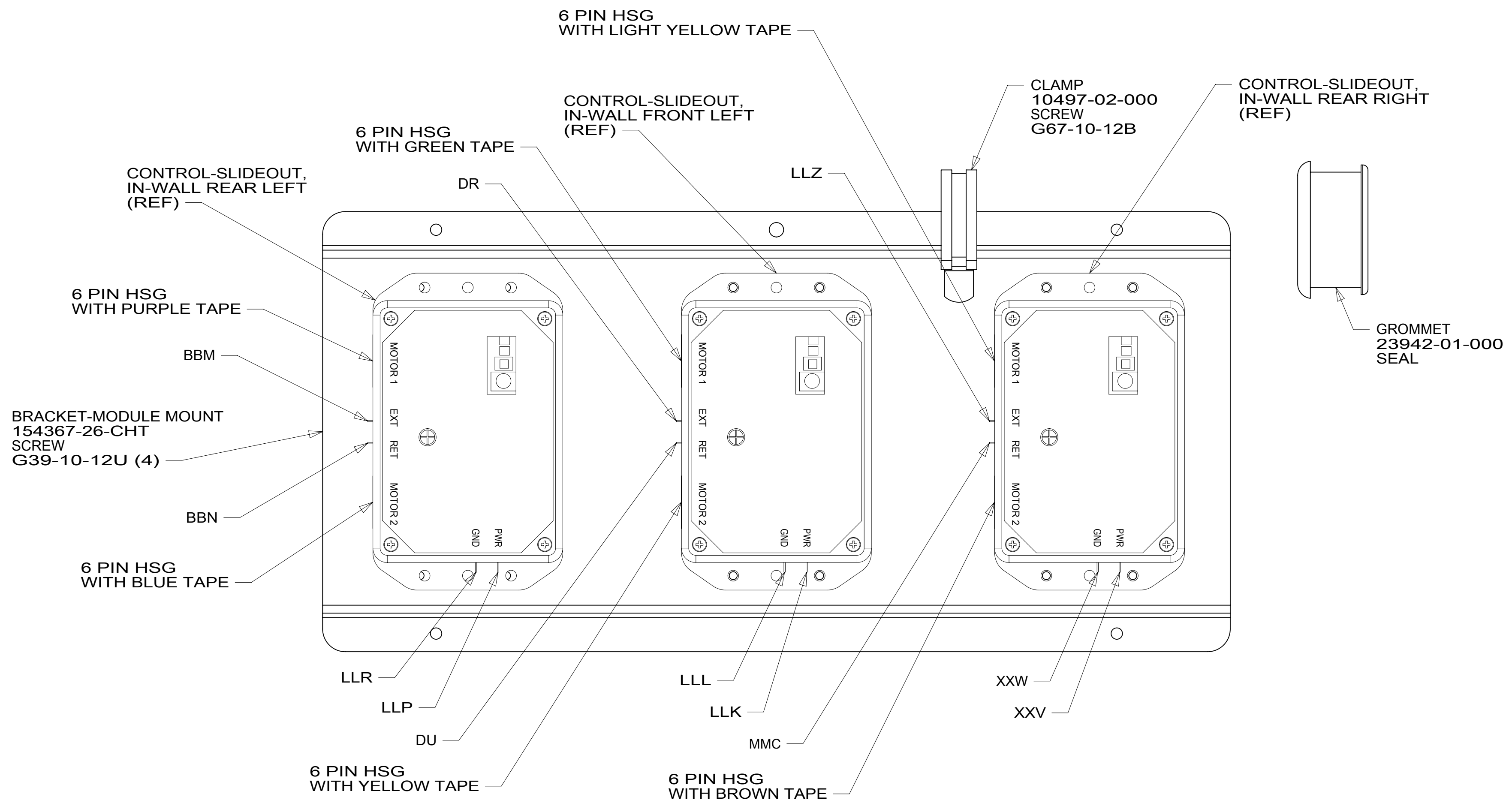

VIEW CB

NOTES:
 1 SEE CHASSIS ELECTRICAL BOX ASM FOR ADDITIONAL INFORMATION.

FOR ELECTRICAL TORQUE SPECIFICATIONS SEE DWG NO. 128783-01-000

FOR ELECTRICAL CALLOUTS SEE DWG NO. 121339-01-000

- 265 CODES/STANDARDS-CSA/CMVSS
- 1B1 CODES/STANDARDS USA
- 1B1 265

FIRST USED	
15 E35B	
DO NOT SCALE DRAWING	
TITLE: WIRING INSTL-CHASSIS	
SHEET 3	PART NO 188857 REV

188857