



**DANGER**

**Danger of electrical shock, burns or death.** Always remove all power sources before attempting any repair, service or diagnostic work. Power can be present from shore power, generator, inverter or battery. All power sources must be disabled and secured before performing any service.



**CAUTION**

If you lack the skills, tools or equipment to perform diagnostic or repair work leave such work to an authorized Winnebago Industries dealer or other qualified shop.



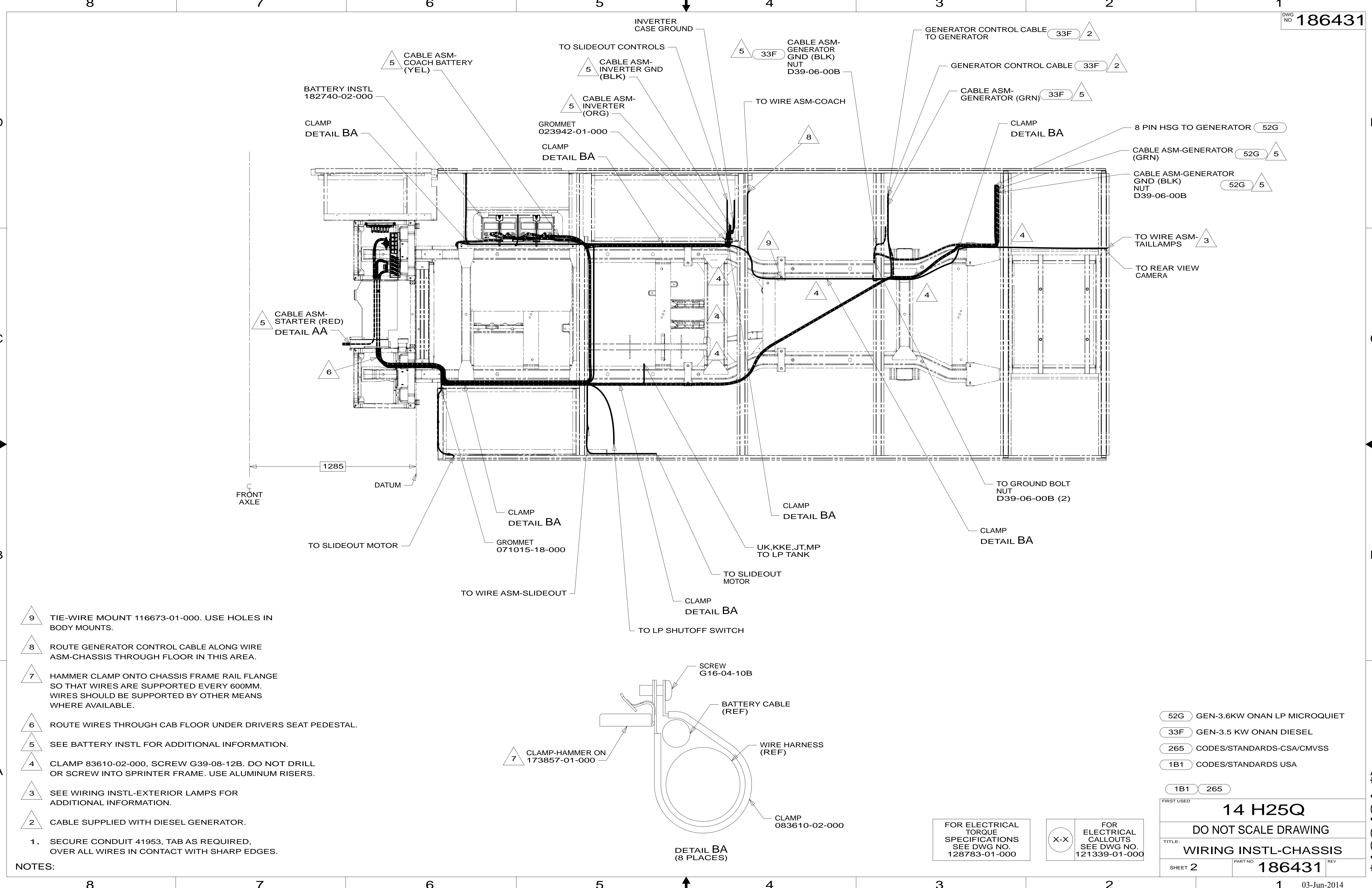

- 9 TIE-WIRE MOUNT 116673-01-000. USE HOLES IN BODY MOUNTS.
- 8 ROUTE GENERATOR CONTROL CABLE ALONG WIRE ASM-CHASSIS THROUGH FLOOR IN THIS AREA.
- 7 HAMMER CLAMP ONTO CHASSIS FRAME RAIL FLANGE SO THAT WIRES ARE SUPPORTED EVERY 600MM. WIRES SHOULD BE SUPPORTED BY OTHER MEANS WHERE AVAILABLE.
- 6 ROUTE WIRES THROUGH CAB FLOOR UNDER DRIVERS SEAT PEDESTAL.
- 5 SEE BATTERY INSTL FOR ADDITIONAL INFORMATION.
- 4 CLAMP 83610-02-000, SCREW G39-08-12B. DO NOT DRILL OR SCREW INTO SPRINTER FRAME. USE ALUMINUM RISERS.
- 3 SEE WIRING INSTL-EXTERIOR LAMPS FOR ADDITIONAL INFORMATION.
- 2 CABLE SUPPLIED WITH DIESEL GENERATOR.

NOTES:  
 1. SECURE CONDUIT 41953, TAB AS REQUIRED, OVER ALL WIRES IN CONTACT WITH SHARP EDGES.

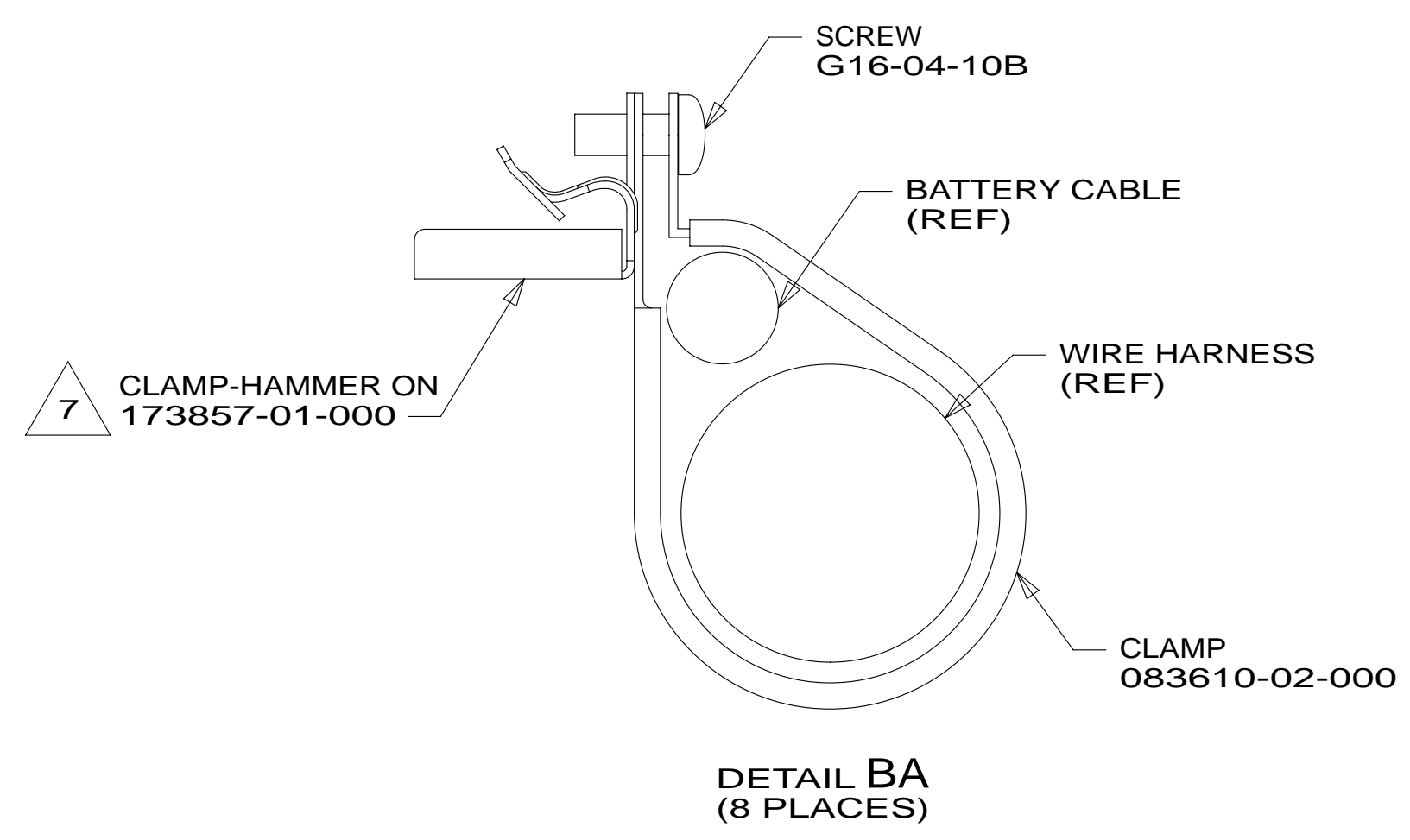

- 52G GEN-3.6KW ONAN LP MICROQUIET
- 33F GEN-3.5 KW ONAN DIESEL
- 265 CODES/STANDARDS-CSA/CMVSS
- 1B1 CODES/STANDARDS USA

FIRST USED	14 H25Q	
DO NOT SCALE DRAWING		
TITLE: WIRING INSTL-CHASSIS		
SHEET 2	PART NO 186431	REV

FOR ELECTRICAL TORQUE SPECIFICATIONS SEE DWG NO. 128783-01-000

FOR ELECTRICAL CALLOUTS SEE DWG NO. 121339-01-000