



DANGER

Danger of electrical shock, burns or death. Always remove all power sources before attempting any repair, service or diagnostic work. Power can be present from shore power, generator, inverter or battery. All power sources must be disabled and secured before performing any service.



CAUTION

If you lack the skills, tools or equipment to perform diagnostic or repair work leave such work to an authorized Winnebago Industries dealer or other qualified shop.

PANEL-CLOSEOUT,
ELECTRICAL
175347-06-CHT
SCREW
G11-08-12U (4)

CIRCUIT BREAKERS
DETAIL CA

PANEL-CLOSEOUT,
ELECTRICAL
175347-02-CHT (2)
SCREW
G39-10-12U (4)

FUSE BLOCK
(CHASSIS SUPPLIED)
(REF)

CHASSIS
BATTERIES
(REF)

FREIGHTLINER
STARTER CABLE

VIEW BA

265 CODES/STANDARDS-CSA/CMVSS

1B1 CODES/STANDARDS USA

1B1 265

FIRST USED
14 L38R

DO NOT SCALE DRAWING

TITLE:
WIRING INSTL-CHASSIS

SHEET 2 PART NO **186059** REV

FOR ELECTRICAL
TORQUE
SPECIFICATIONS
SEE DWG NO.
128783-01-000

FOR
ELECTRICAL
CALLOUTS
SEE DWG NO.
121339-01-000

X-X

A * 186059

1 CIRCUIT BREAKER-30 AMP
93655-02-000 (3)
SCREW
G52-06-05U (3)
SPACER-CIRCUIT BREAKER
141789-01-000 (3)

LABEL-CIRCUIT BREAKER
93236-77-000

PLUG-PLASTIC
81211-06-000 (6)

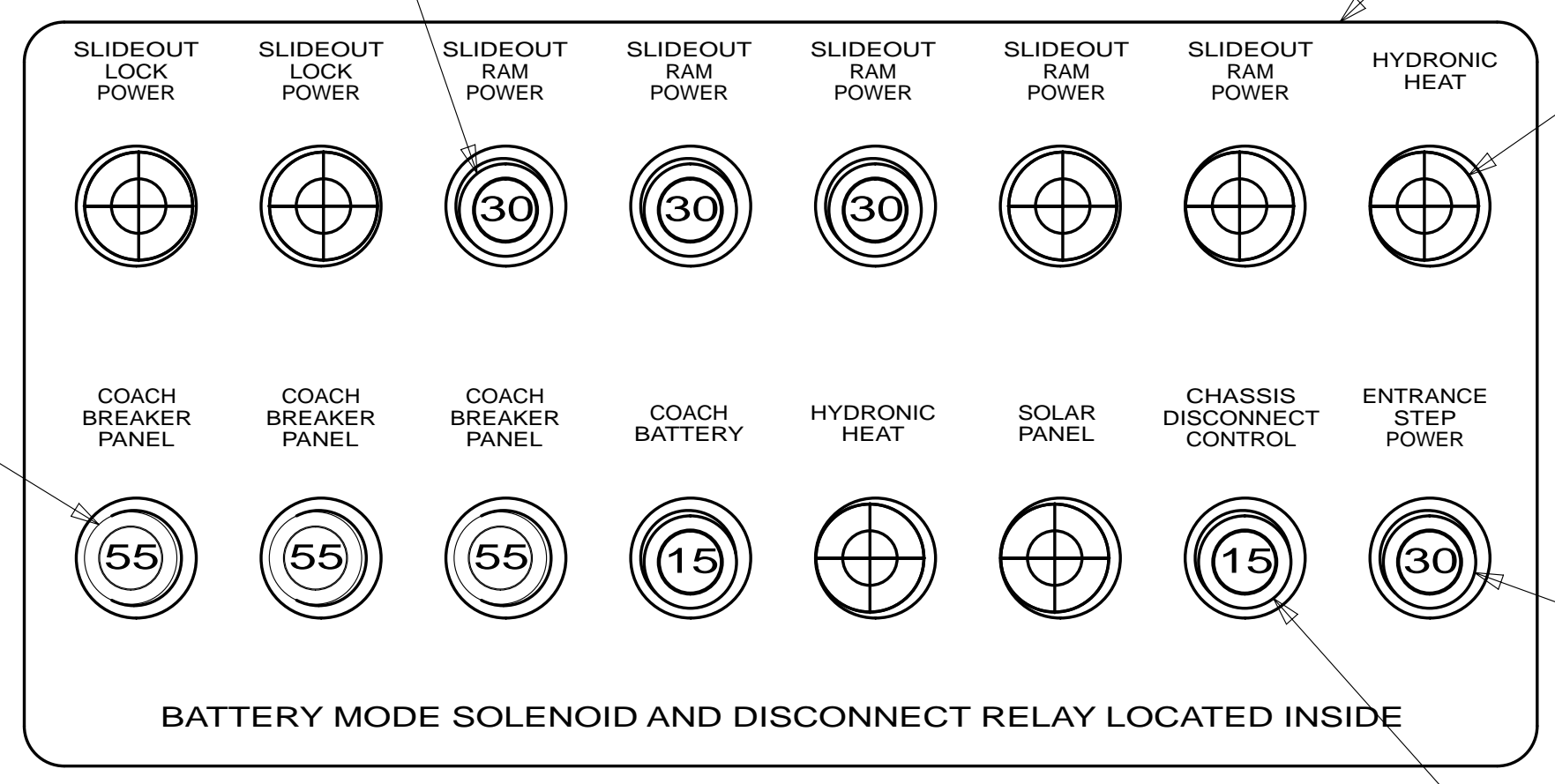

BATTERY MODE SOLENOID AND DISCONNECT RELAY LOCATED INSIDE

1 CIRCUIT BREAKER-30 AMP
93655-02-000
SCREW
G52-06-05U
SPACER-CIRCUIT BREAKER
141789-01-000

1 CIRCUIT BREAKER-15 AMP
93654-02-000 (2)
SCREW
G52-06-05U
SPACER-CIRCUIT BREAKER
141789-01-000 (2)

DETAIL CA

CIRCUIT BREAKER-55 AMP
113482-01-000 (3)

RELAY
63912-02-000
(CHASSIS BATTERY
DISCONNECT LOCKOUT)
PLUG INTO WIRE ASM-CHASSIS

CABLE ASM (RED)
FROM CHASSIS BATTERY
TO CHASSIS SIDE OF
AUX START SOLENOID

CABLE ASM (PUR)
FROM CHASSIS
BATTERY DISCONNECT
TO CHASSIS
ISOLATED STUD

CABLE ASM (YEL)
FROM STUD, JUMP START
TO COACH SIDE OF
AUX START SOLENOID

CABLE ASM (GRN)
FROM COACH BATTERY
DISCONNECT RELAY
TO PASS THRU STUD
IN FRONT LEFT COMPT

CABLE ASM (BLU)
TO LEVELING PUMP

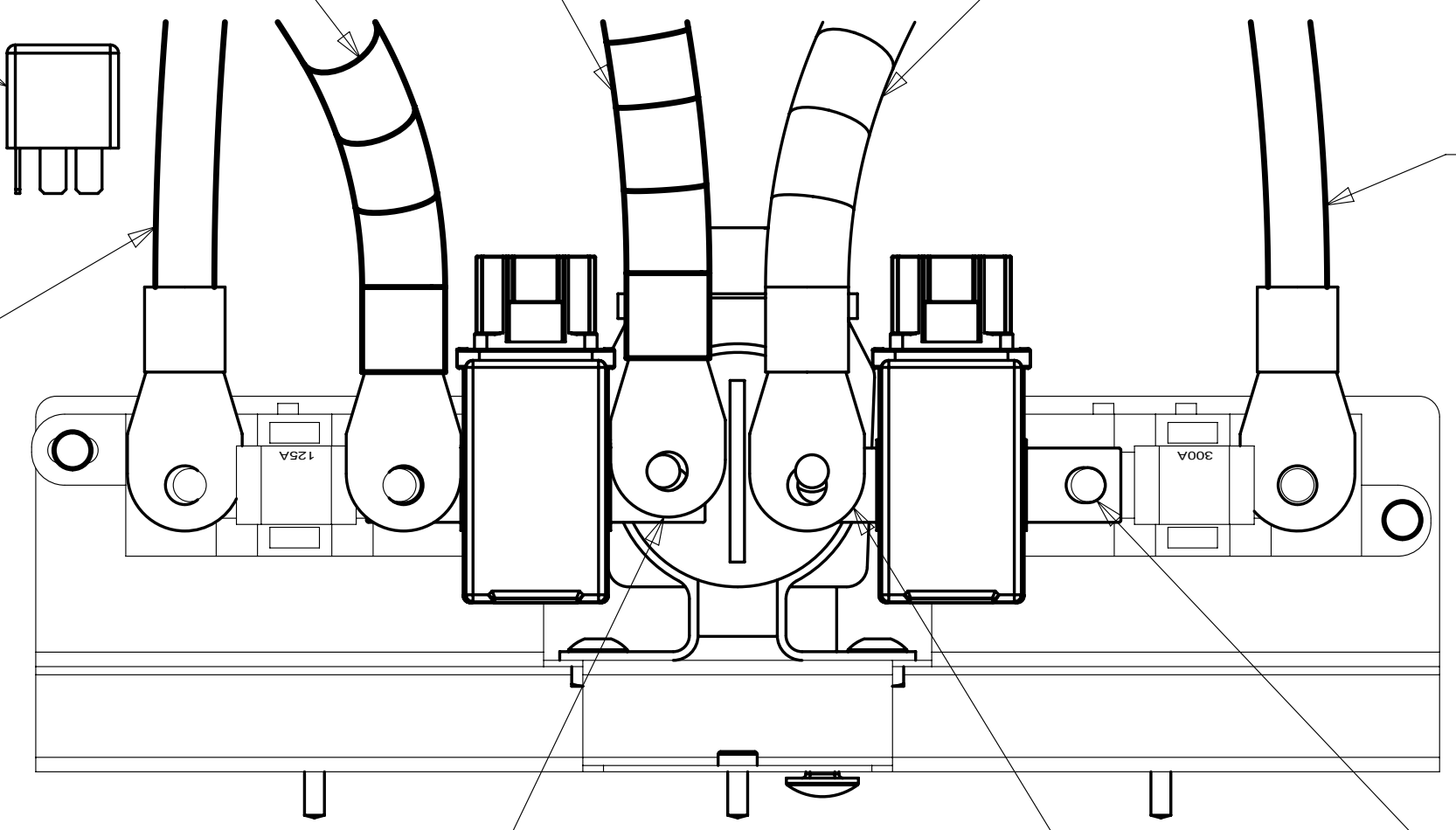

FEED-1
(CHASSIS)

VIEW CB

FEED-2
(COACH)

CONNECT COACH
BREAKER FEED HERE

TO ISOLATED
STUD

CABLE ASM-6 GA
140228-01-006

BUSS BAR
141744-02-000

BUSS BAR
141744-01-000

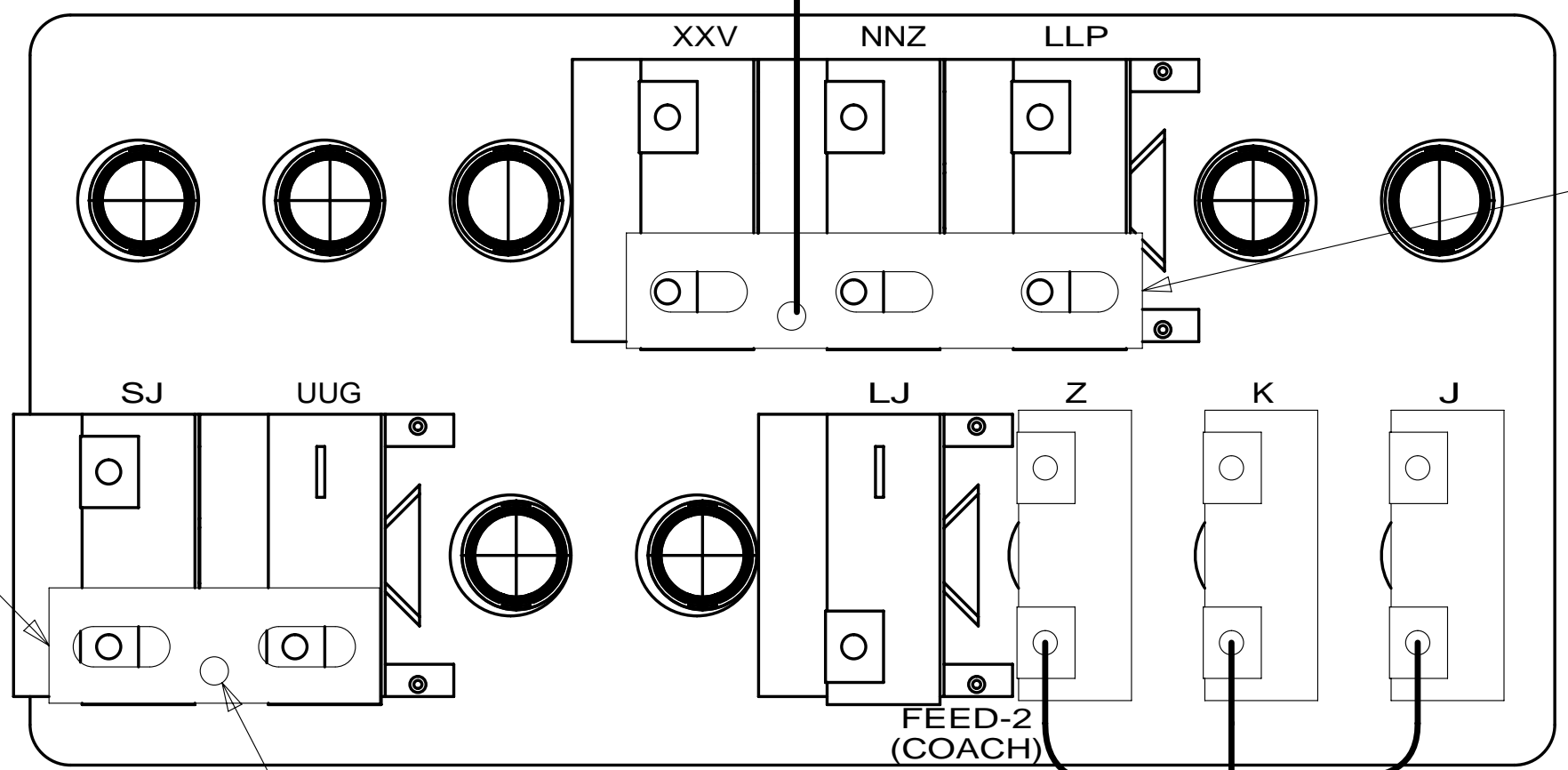

FEED-1
(CHASSIS)

FEED-2
(COACH)

WIRE ASM-BREAKERS
176775-02-009

FROM
DISCONNECTED
SIDE OF COACH
DISCONNECT
DETAIL CB

DETAIL CA
(BACK VIEW-COMPONENTS)

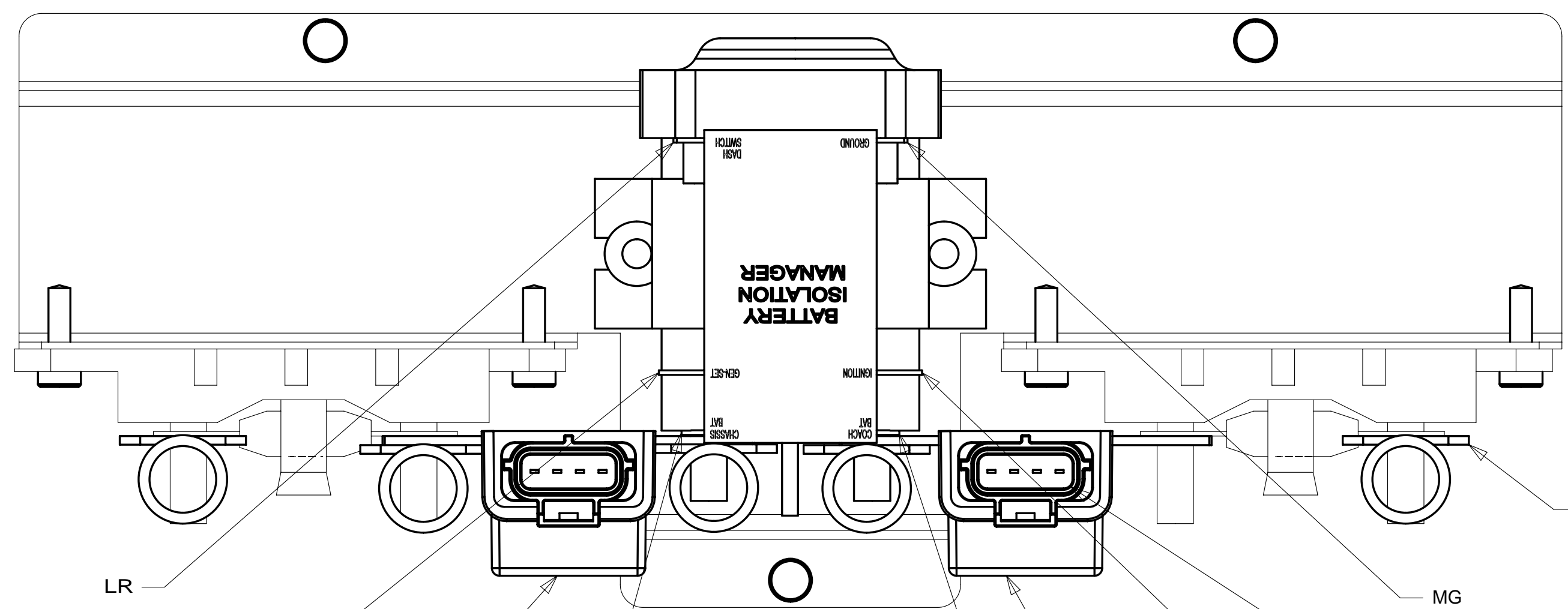

LR

LP

CHASSIS
DISCONNECT

FEED-1
(CHASSIS)

DETAIL CC

FEED-2
(COACH)

COACH
DISCONNECT

CONNECTOR WITH
YELLOW TAPE FROM
WIRE ASM-CHASSIS

JJZ

MG

CONNECT COACH
BREAKER FEED HERE

1 REPLACE EXISTING SCREW TO PROPERLY ATTACH
BREAKER TO BUSS BAR.

NOTES:

FOR ELECTRICAL
TORQUE
SPECIFICATIONS
SEE DWG NO.
128783-01-000

X-X
FOR
ELECTRICAL
CALLOUTS
SEE DWG NO.
121339-01-000

265 CODES/STANDARDS-CSA/CMVSS

1B1 CODES/STANDARDS USA

1B1 265

FIRST USED
14 L38R

DO NOT SCALE DRAWING

TITLE:
WIRING INSTL-CHASSIS

SHEET 3 PART NO **186059** REV

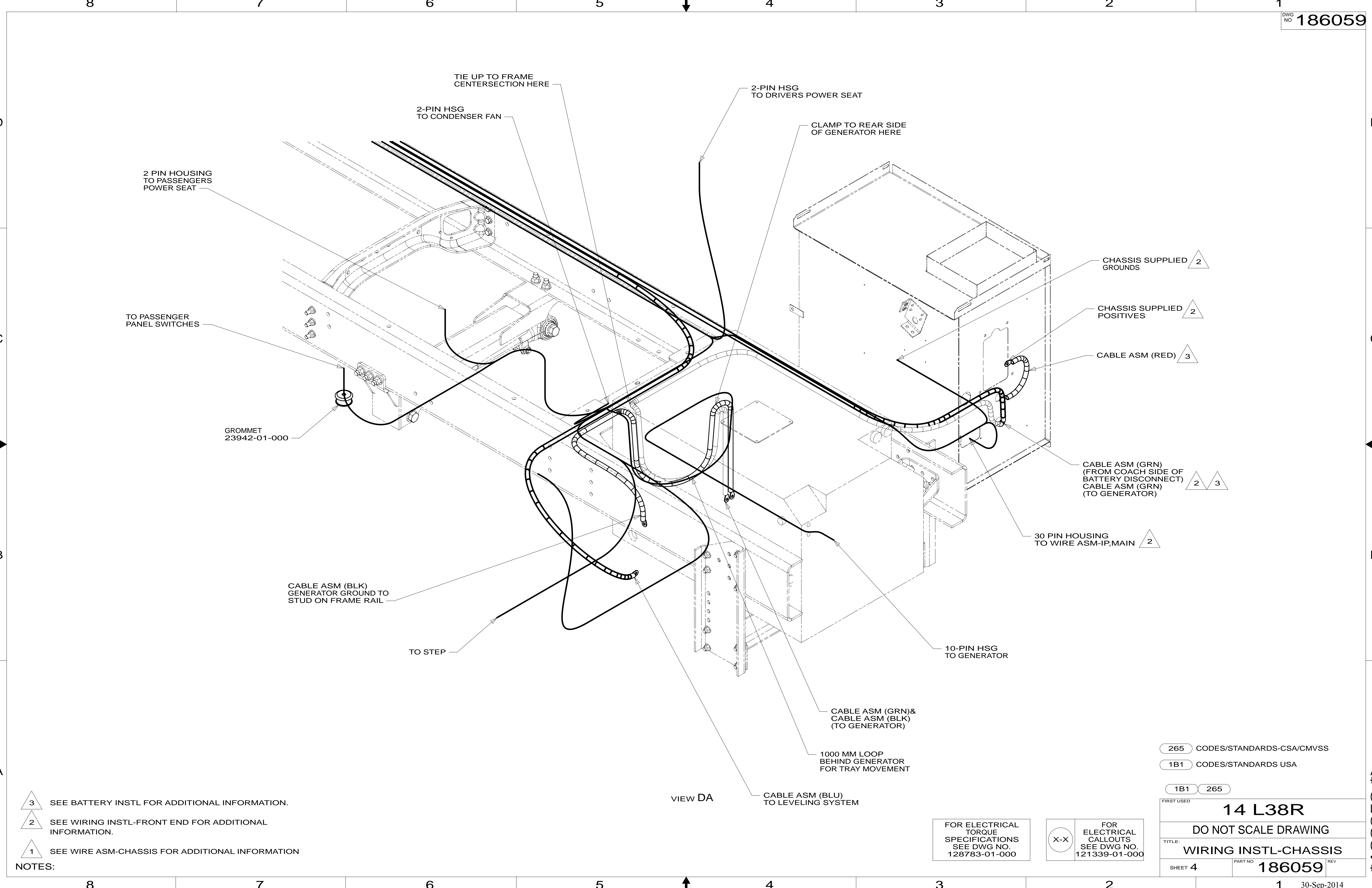

- 3 SEE BATTERY INSTL FOR ADDITIONAL INFORMATION.
- 2 SEE WIRING INSTL-FRONT END FOR ADDITIONAL INFORMATION.
- 1 SEE WIRE ASM-CHASSIS FOR ADDITIONAL INFORMATION

NOTES:

FOR ELECTRICAL TORQUE SPECIFICATIONS SEE DWG NO. 128783-01-000

FOR ELECTRICAL CALLOUTS SEE DWG NO. 121339-01-000

- 265 CODES/STANDARDS-CSA/CMVSS
- 1B1 CODES/STANDARDS USA
- 1B1 265

FIRST USED	14 L38R	
TITLE:	DO NOT SCALE DRAWING	
	WIRING INSTL-CHASSIS	
SHEET 4	PART NO 186059	REV

* 186059 *