



DANGER

Danger of electrical shock, burns or death. Always remove all power sources before attempting any repair, service or diagnostic work. Power can be present from shore power, generator, inverter or battery. All power sources must be disabled and secured before performing any service.



CAUTION

If you lack the skills, tools or equipment to perform diagnostic or repair work leave such work to an authorized Winnebago Industries dealer or other qualified shop.

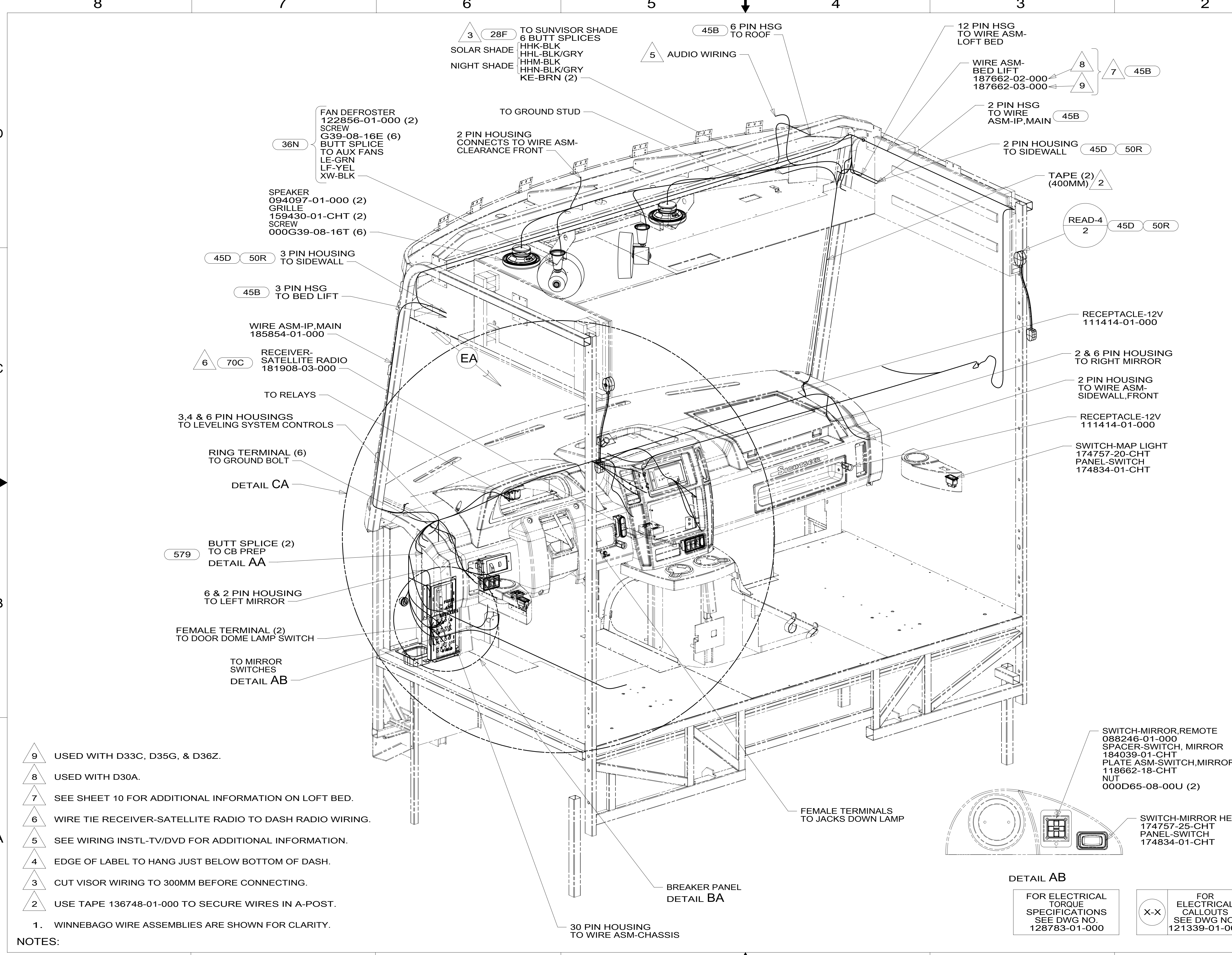

- 50R FRONT BUNK-PULL DOWN
- 45D LOFT BED - WITHOUT
- 45B LOFT BED
- 70C RADIO - SATELLITE
- 579 RADIO - CB WIRE PREP
- 36N FANS-DEFROSTER, AUXILIARY
- 28F FRONT SHADE-POWERED
- 265 CODES/STANDARDS-CSA/CMVSS
- 1B1 CODES/STANDARDS USA

1B1 265

WINNEBAGO COPYRIGHT 2014 WINNEBAGO INDUSTRIES, INC.

DFTR	ORIG. DATE
CHKR	ALL DIMENSIONS ARE IN MILLIMETERS
P.E.	FIRST USED
M.E.	
DSNR	14 D-SERIES

UNSPECIFIED TOLERANCES ARE:

WHOLE DIM (X)	: 3
ONE-PLACE (X.X)	: 1.5
TWO-PLACE (X.XX)	: 0.50
ANGLE	: 1°

THIRD ANGLE PROJECTION

DO NOT SCALE DRAWING REFER TO ES0018 FOR FASTENER TIGHTENING GUIDELINES

TITLE: **WIRING INSTL-FRONT END**

SHEET **1** OF **10** PART NO **185853** REV

REF: **1** 24-Feb-2015

- NOTES:**
1. WINNEBAGO WIRE ASSEMBLIES ARE SHOWN FOR CLARITY.
 2. USE TAPE 136748-01-000 TO SECURE WIRES IN A-POST.
 3. CUT VISOR WIRING TO 300MM BEFORE CONNECTING.
 4. EDGE OF LABEL TO HANG JUST BELOW BOTTOM OF DASH.
 5. SEE WIRING INSTL-TV/DVD FOR ADDITIONAL INFORMATION.
 6. WIRE TIE RECEIVER-SATELLITE RADIO TO DASH RADIO WIRING.
 7. SEE SHEET 10 FOR ADDITIONAL INFORMATION ON LOFT BED.
 8. USED WITH D30A.
 9. USED WITH D33C, D35G, & D36Z.

DETAIL AB

FOR ELECTRICAL TORQUE SPECIFICATIONS SEE DWG NO. 128783-01-000

FOR ELECTRICAL CALLOUTS SEE DWG NO. 121339-01-000

185853

8 7 6 5 4 3 2 1

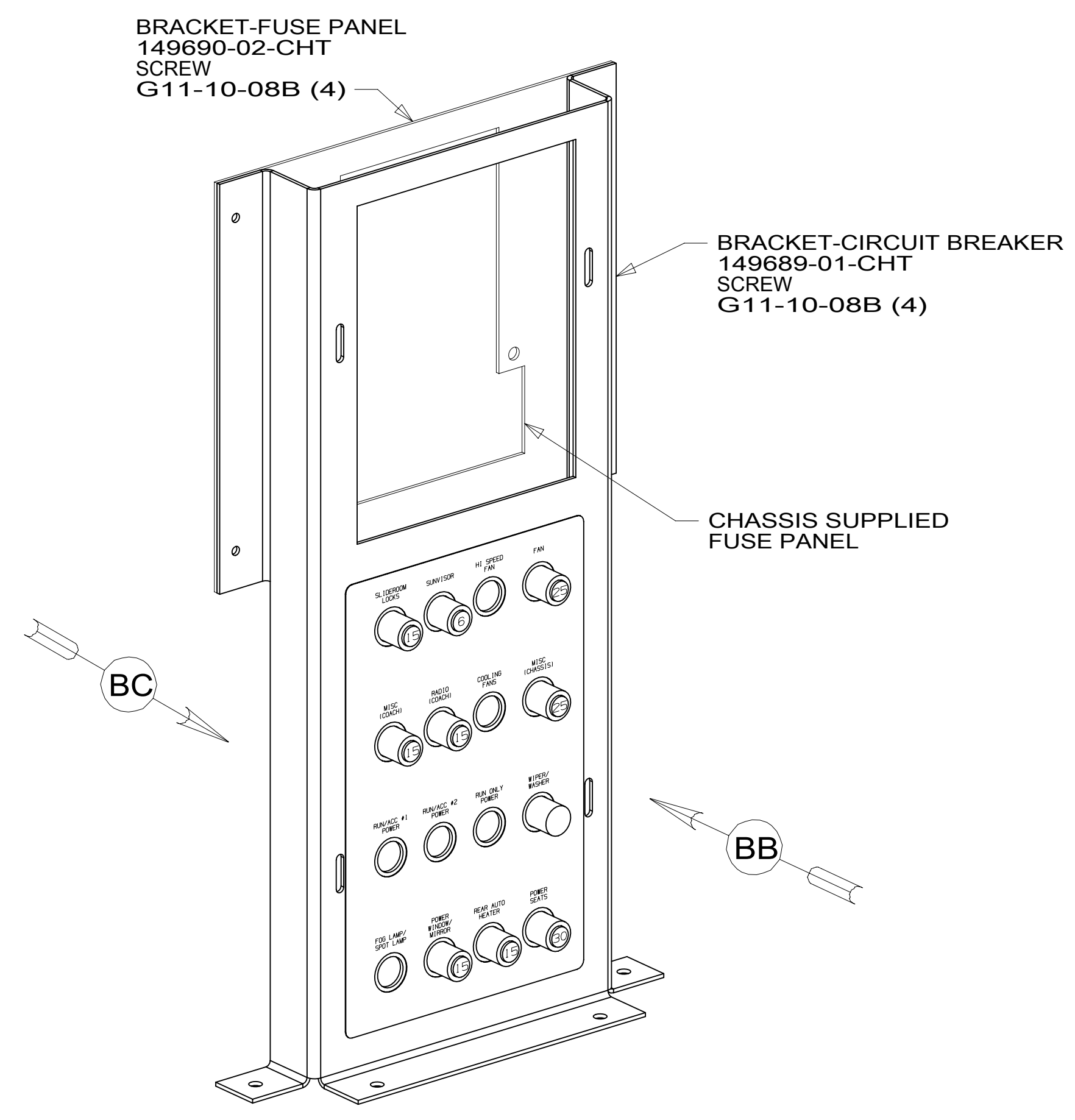
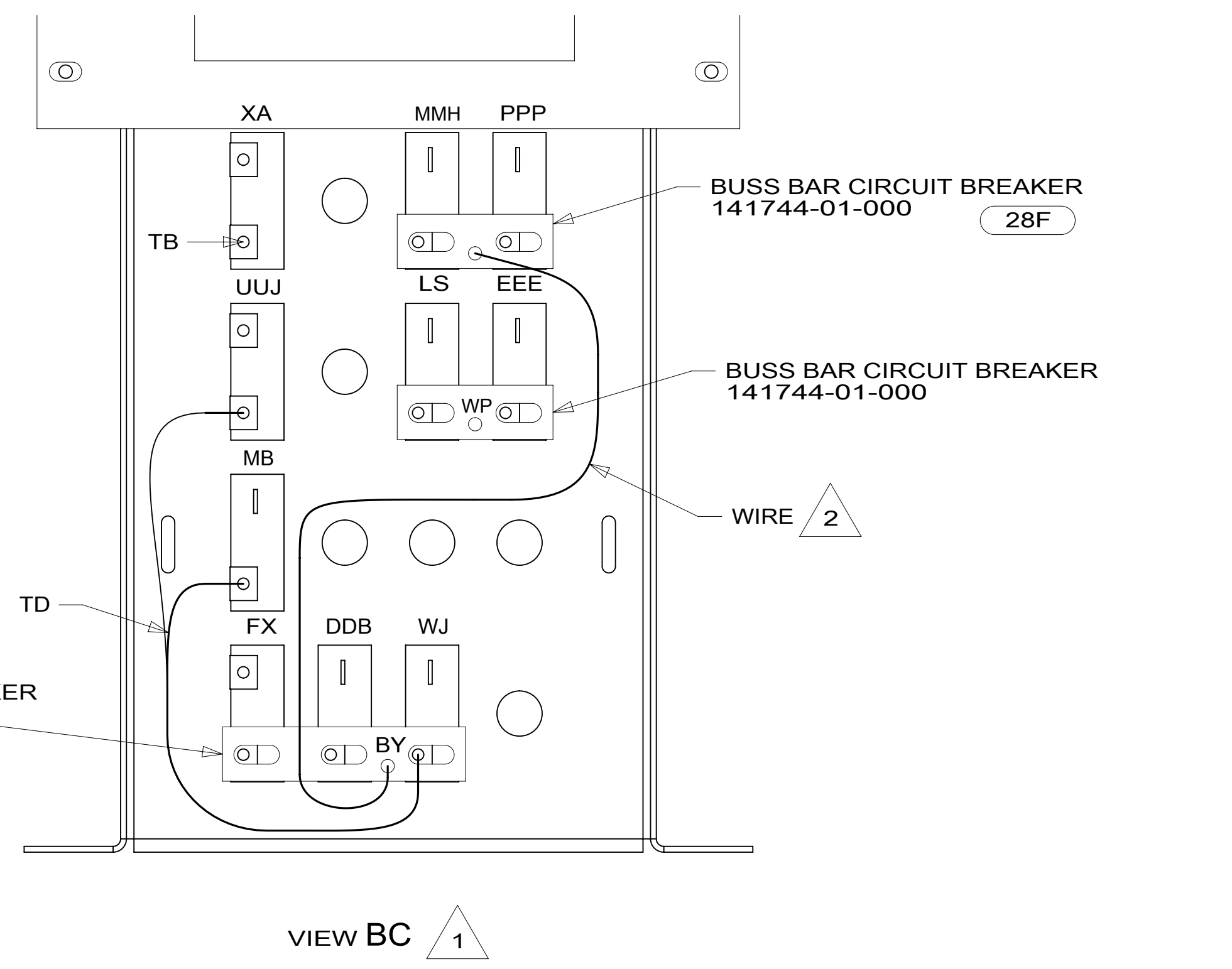
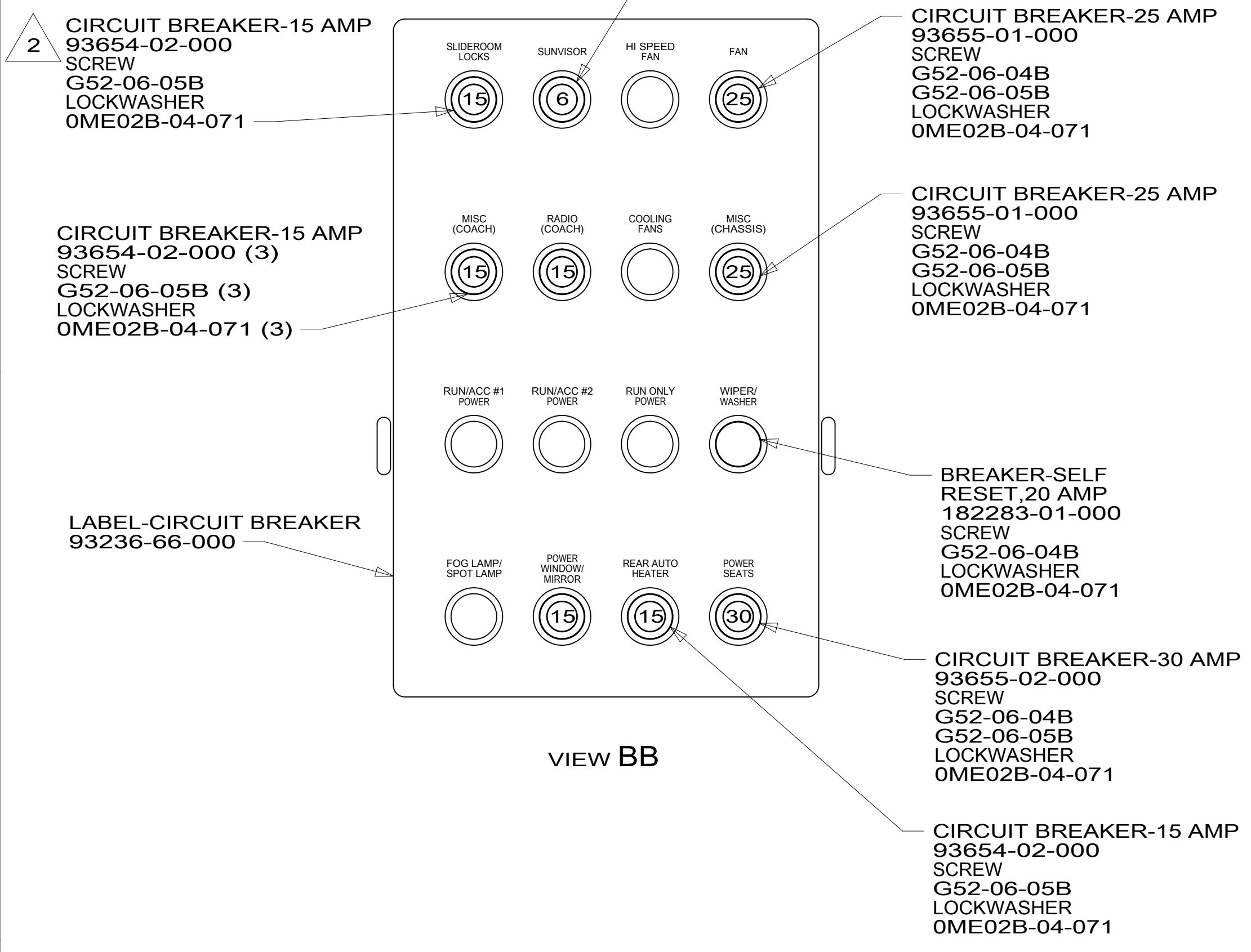

2 USED ON D33C AND D35G FOR THE SLIDEOUT LOCK.
1 ALL CIRCUITS ARE IN WIRE ASM-IP,MAIN.

NOTES:

FOR ELECTRICAL TORQUE SPECIFICATIONS SEE DWG NO. 128783-01-000

FOR ELECTRICAL CALLOUTS SEE DWG NO. 121339-01-000

- 28F FRONT SHADE-POWERED
- 265 CODES/STANDARDS-CSA/CMVSS
- 1B1 CODES/STANDARDS USA

1B1	265
FIRST USED	
14 D-SERIES	
DO NOT SCALE DRAWING	
TITLE: WIRING INSTL-FRONT END	
SHEET 2	PART NO 185853 REV

185853

8

7

6

5

4

3

2

1

RELAY
63912-02-000 (2)
SCREW
G11-08-08U (2)

PART OF WIRE
ASM-IP,MAIN

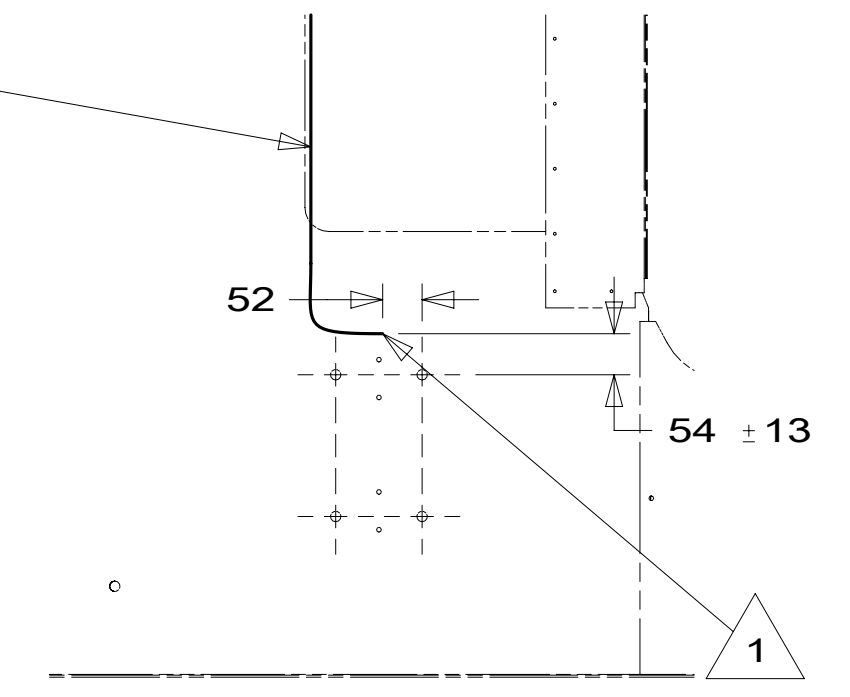

DETAIL CB 64Q

DETAIL DA

DETAIL DB

STUD-FEED THRU
118499-01-000

FUSES
AND
BREAKERS

BRACKET-MOUNTING
118571-07-000
NUT
D11-10-00B (2)

FORD DIAGNOSTIC CONNECTOR
NUT-SPEED
4092-1-03-000
SCREW
G-11-10-10U (2)

SEAL-WIRES,CAB FLOOR
134542-01-CHT (2)
SCREW
G39-10-12B (6)

2 PIN HSG TO
DRIVER'S SEAT
DETAIL CB

DETAIL CA

- 64Q SEAT PED-6-WAY POWER DRIVER
- 265 CODES/STANDARDS-CSA/CMVSS
- 1B1 CODES/STANDARDS USA

1B1 265

FIRST USED	
14 D-SERIES	
DO NOT SCALE DRAWING	
TITLE: WIRING INSTL-FRONT END	
SHEET 3	PART NO 185853 REV
1 24-Feb-2015	

FOR ELECTRICAL
TORQUE
SPECIFICATIONS
SEE DWG NO.
128783-01-000

X-X
FOR
ELECTRICAL
CALLOUTS
SEE DWG NO.
121339-01-000

1 LEAVE 675±50MM OF WIRE FOR SEAT TRAVEL.
NOTES:

8

7

6

5

4

3

2

1

*185853 *A

RADIO-AM/FM/DVD,
TOUCH,2-DIN
183820-16-000
OR
183820-17-000 (70C)
SCREW
76790-03-000(4)
DETAIL GA

PANEL-SWITCH
174834-03-CHT

SWITCH-BLANK
145754-01-CHT

SWITCH-RADIO POWER
174757-12-CHT

SWITCH-REAR
AUTO HEATER
174757-28-CHT

SWITCH-DEFROST FAN
174757-14-CHT (36N)
SWITCH-BLANK
145754-01-CHT (2)

- (70C) RADIO-SATELLITE
- (28F) FRONT SHADE-POWERED
- (36N) FANS-DEFROSTER, AUXILIARY
- (265) CODES/STANDARDS-CSA/CMVSS
- (1B1) CODES/STANDARDS USA

FIRST USED	
14 D-SERIES	
DO NOT SCALE DRAWING	
TITLE: WIRING INSTL-FRONT END	
SHEET 4	PART NO 185853 REV
1 24-Feb-2015	

FOR ELECTRICAL
TORQUE
SPECIFICATIONS
SEE DWG NO.
128783-01-000

FOR
ELECTRICAL
CALLOUTS
SEE DWG NO.
121339-01-000

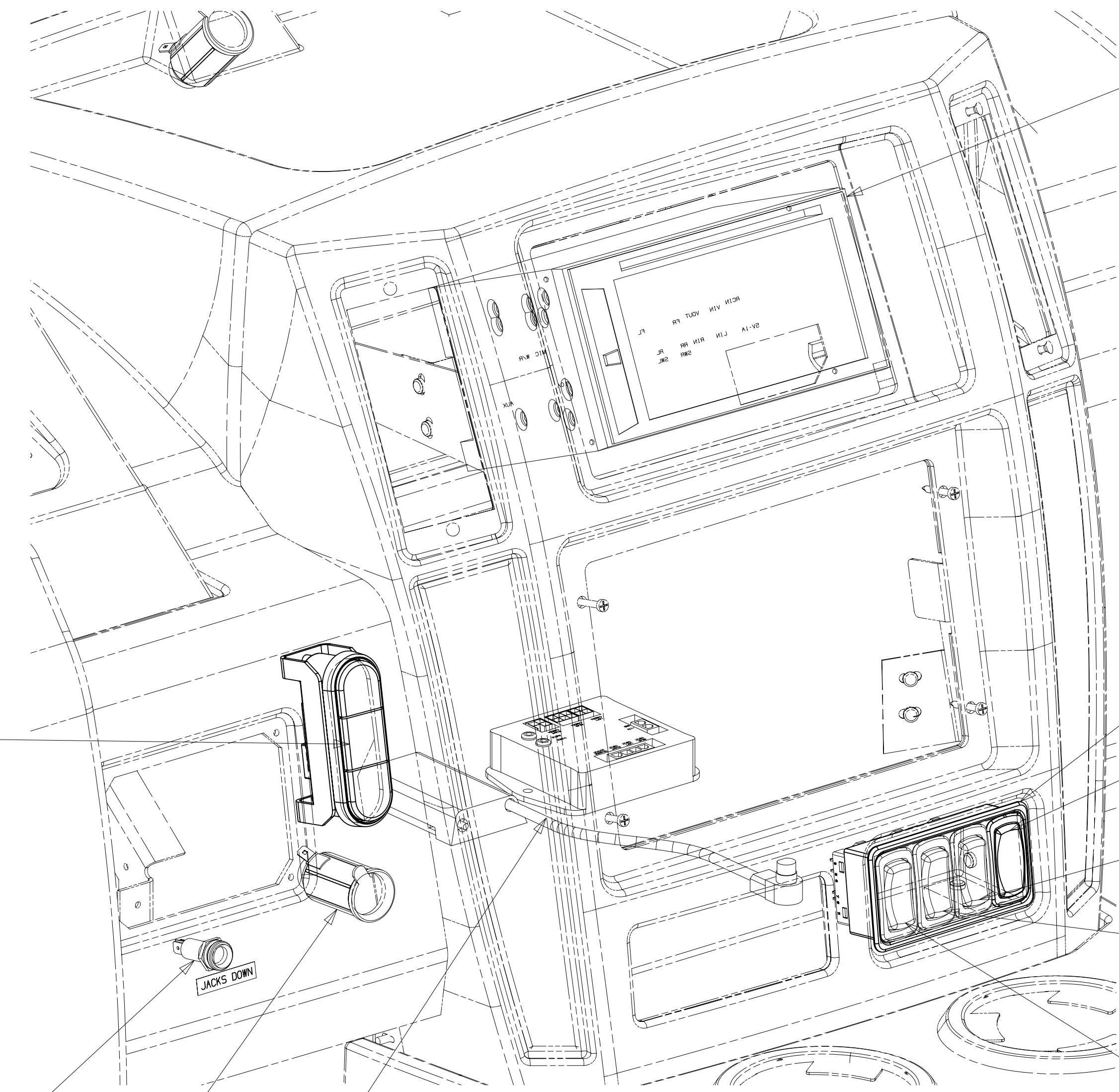

RECEPTACLE-12V
111414-01-000

SWITCH-VIDEO CAMERA
180731-07-000

(4) (5) LIGHT ASM-
INDICATOR,RED
190682-01-000
LABEL-JACKS DOWN
133533-01-CHT

(3) INFORMATION SWITCH
BEZEL-SWITCH
172173-01-CHT
CLAMP-BEZEL
172175-01-CHT
SCREW
G11-08-08U (2)

SWITCH-BATTERY BOOST
174757-31-CHT

INSERT ASM-SWITCH,HDLMP
155589-10-CHT
MOUNT-HEADLAMP-SWITCH
155516-01-CHT
SEAL
155523-01-CHT
WASHER
E13-10-00U (7)
NUT
D65-08-00U (7)

SWITCH-NIGHT SHADE
174757-11-CHT (28F)
SWITCH-BLANK
145754-01-CHT (1)

SWITCH-SOLAR SHADE
174757-10-CHT (28F)
SWITCH-BLANK
145754-01-CHT (1)

DETAIL DA

DETAIL DB

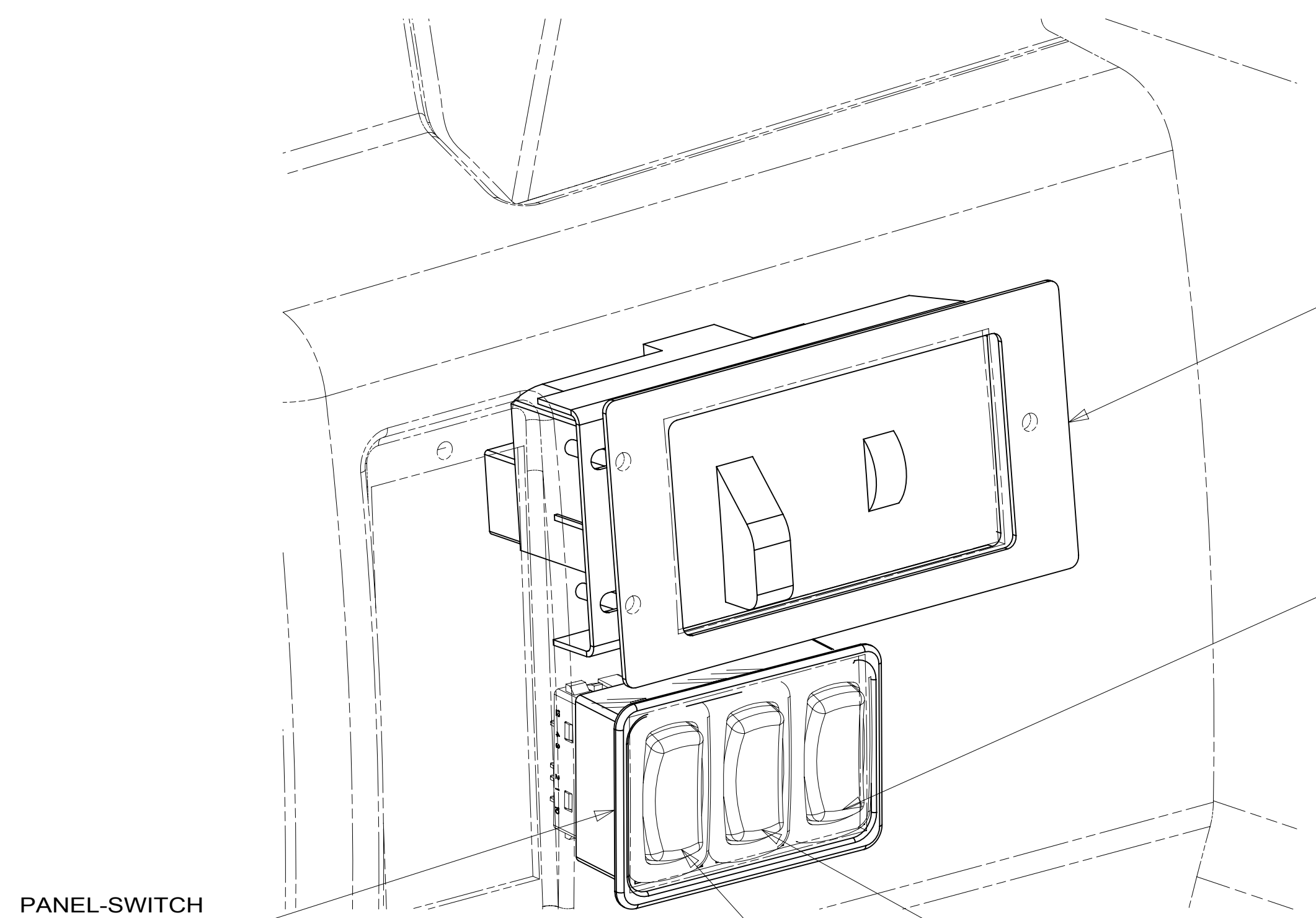

PANEL-SWITCH
174834-02-CHT

- NOTES:
- (5) WIRING FROM LEVELING SYSTEM. SEE LEVELING SYSTEM INSTL FOR ADDITIONAL INFORMATION.
 - (4) CONNECT POSITIVE WIRE TO TERMINAL MARKED WITH "RED".
 - (3) CHASSIS SUPPLIED
 - (2) WITHOUT (36N)
 - (1) WITHOUT (28F)

185853

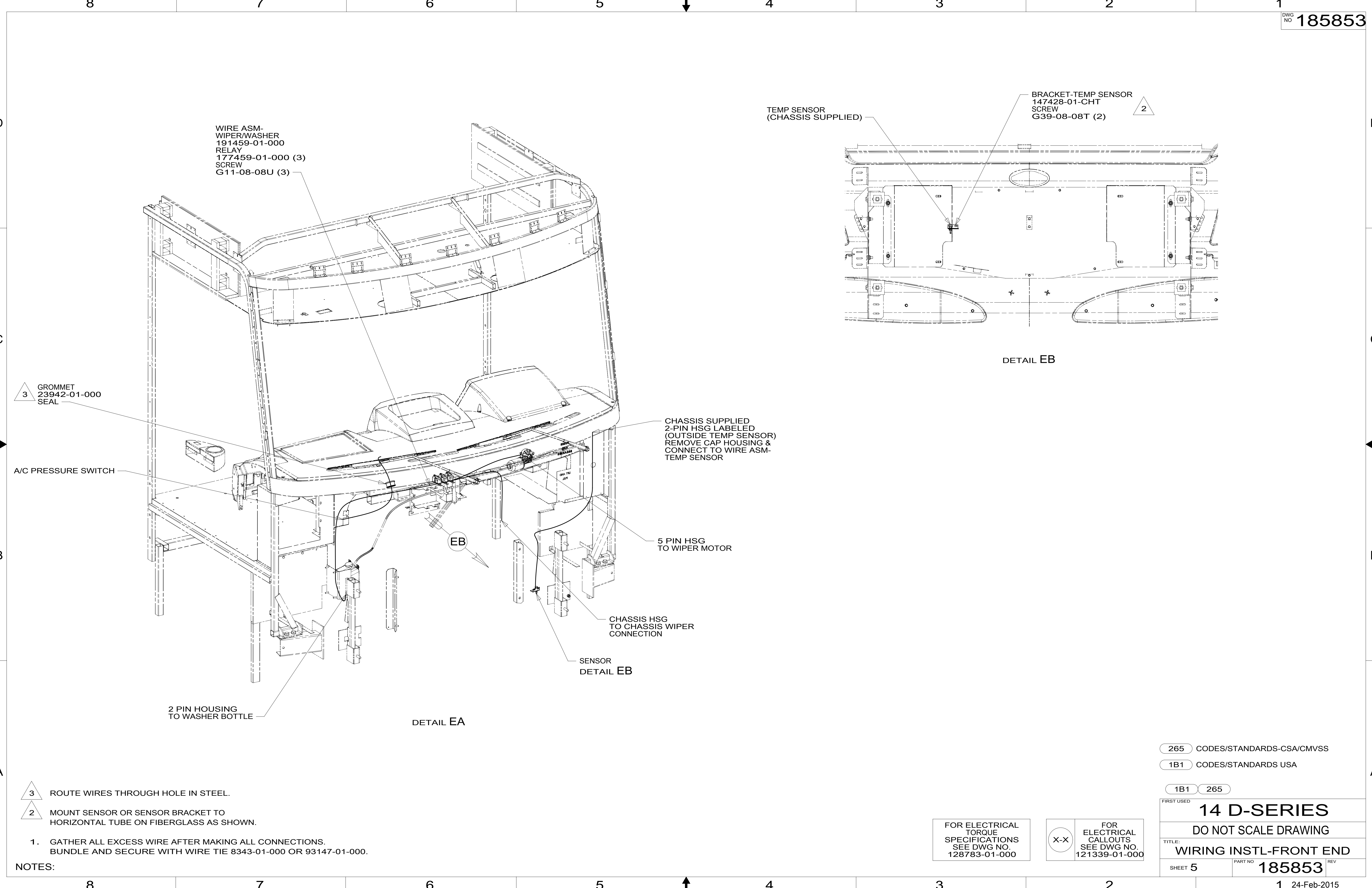

3 GROMMET 23942-01-000 SEAL

A/C PRESSURE SWITCH

2 PIN HOUSING TO WASHER BOTTLE

WIRE ASM-WIPER/WASHER 191459-01-000 RELAY 177459-01-000 (3) SCREW G11-08-08U (3)

CHASSIS SUPPLIED 2-PIN HSG LABELED (OUTSIDE TEMP SENSOR) REMOVE CAP HOUSING & CONNECT TO WIRE ASM-TEMP SENSOR

5 PIN HSG TO WIPER MOTOR

CHASSIS HSG TO CHASSIS WIPER CONNECTION

SENSOR DETAIL EB

TEMP SENSOR (CHASSIS SUPPLIED)

BRACKET-TEMP SENSOR 147428-01-CHT SCREW G39-08-08T (2)

DETAIL EB

DETAIL EA

3 ROUTE WIRES THROUGH HOLE IN STEEL.

2 MOUNT SENSOR OR SENSOR BRACKET TO HORIZONTAL TUBE ON FIBERGLASS AS SHOWN.

1. GATHER ALL EXCESS WIRE AFTER MAKING ALL CONNECTIONS. BUNDLE AND SECURE WITH WIRE TIE 8343-01-000 OR 93147-01-000.

NOTES:

FOR ELECTRICAL TORQUE SPECIFICATIONS SEE DWG NO. 128783-01-000

FOR ELECTRICAL CALLOUTS SEE DWG NO. 121339-01-000

265 CODES/STANDARDS-CSA/CMVSS

1B1 CODES/STANDARDS USA

1B1 265

14 D-SERIES

DO NOT SCALE DRAWING

TITLE: WIRING INSTL-FRONT END

SHEET 5 PART NO 185853 REV

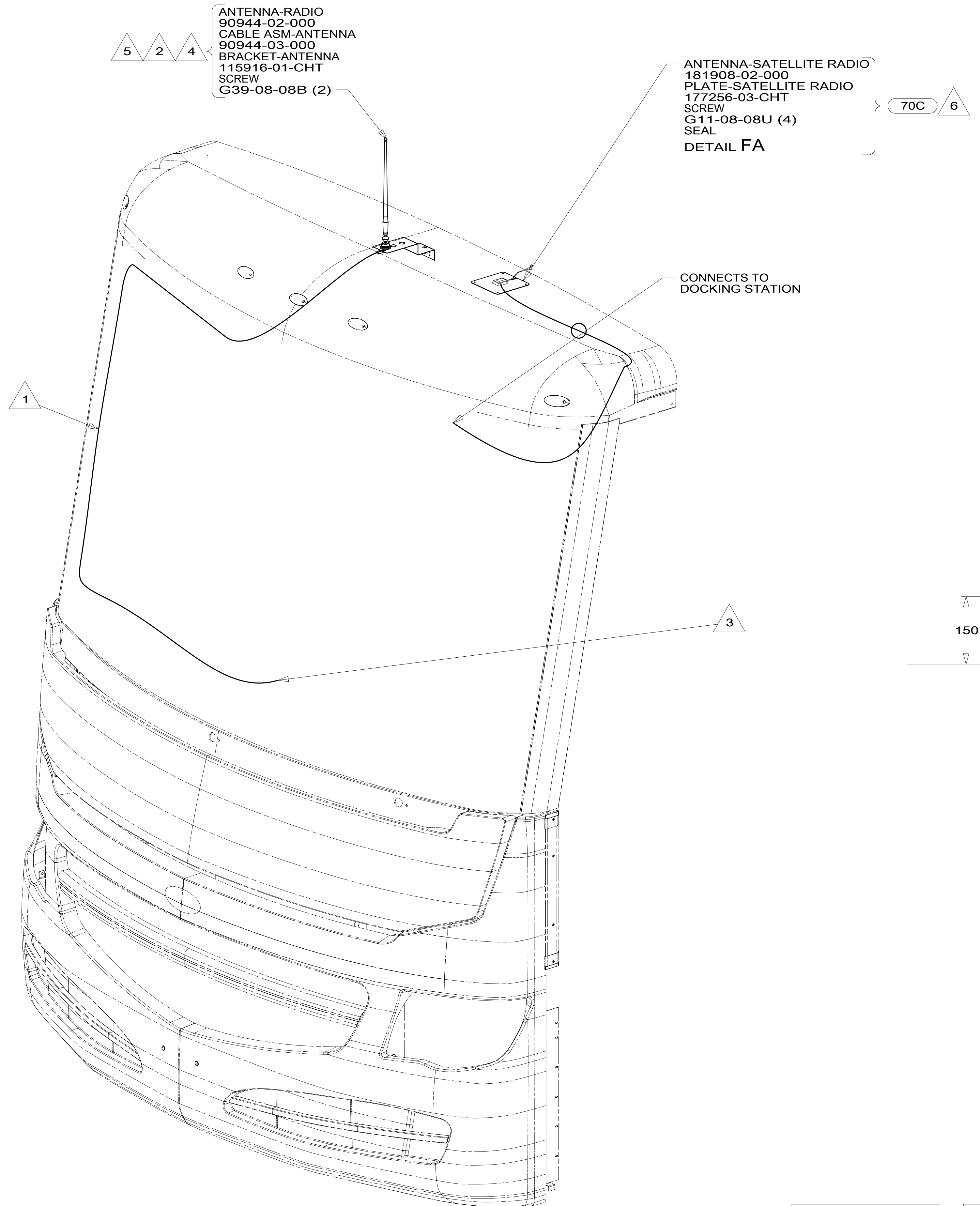

- 6 MOUNT ANTENNA SUCH THAT BASE IS SQUARE W/REAR OF ROOF CAP & HOLE IS DIRECTLY OVER HOLE IN FIBERGLASS. SEAL HOLE IN ROOF CAP, BASE AT SCREWS.
- 5 REMOVE AND REINSTALL AFTER PAINT.
- 4 USE HOLE IN BRACKET AS GUIDE TO DRILL 13 DIAMETER HOLE IN FIBERGLASS.
- 3 TO RADIO.
- 2 SEAL AROUND ANTENNA BASE.
- 1 ROUTE CABLE ALONG A-POST, UNDER TRIM COVER.

NOTES:

- 70C RADIO - SATELLITE
- 265 CODES/STANDARDS-CSA/CMVSS
- 1B1 CODES/STANDARDS USA

FIRST USED	14 D-SERIES
DO NOT SCALE DRAWING	
TITLE: WIRING INSTL-FRONT END	
SHEET 6	PART NO 185853 REV

FOR ELECTRICAL TORQUE SPECIFICATIONS SEE DWG NO. 128783-01-000

FOR ELECTRICAL CALLOUTS SEE DWG NO. 121339-01-000

*185853 *A

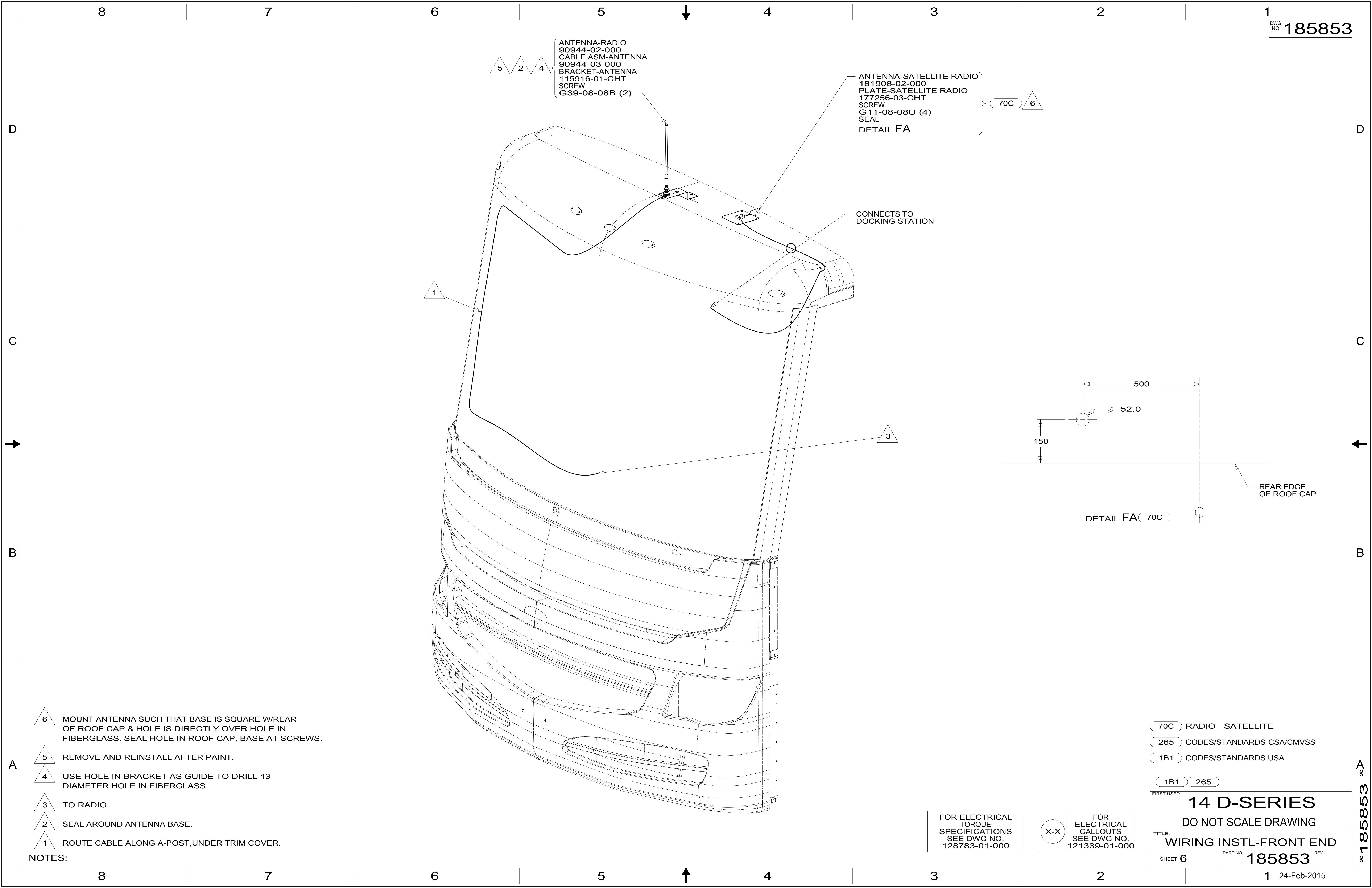

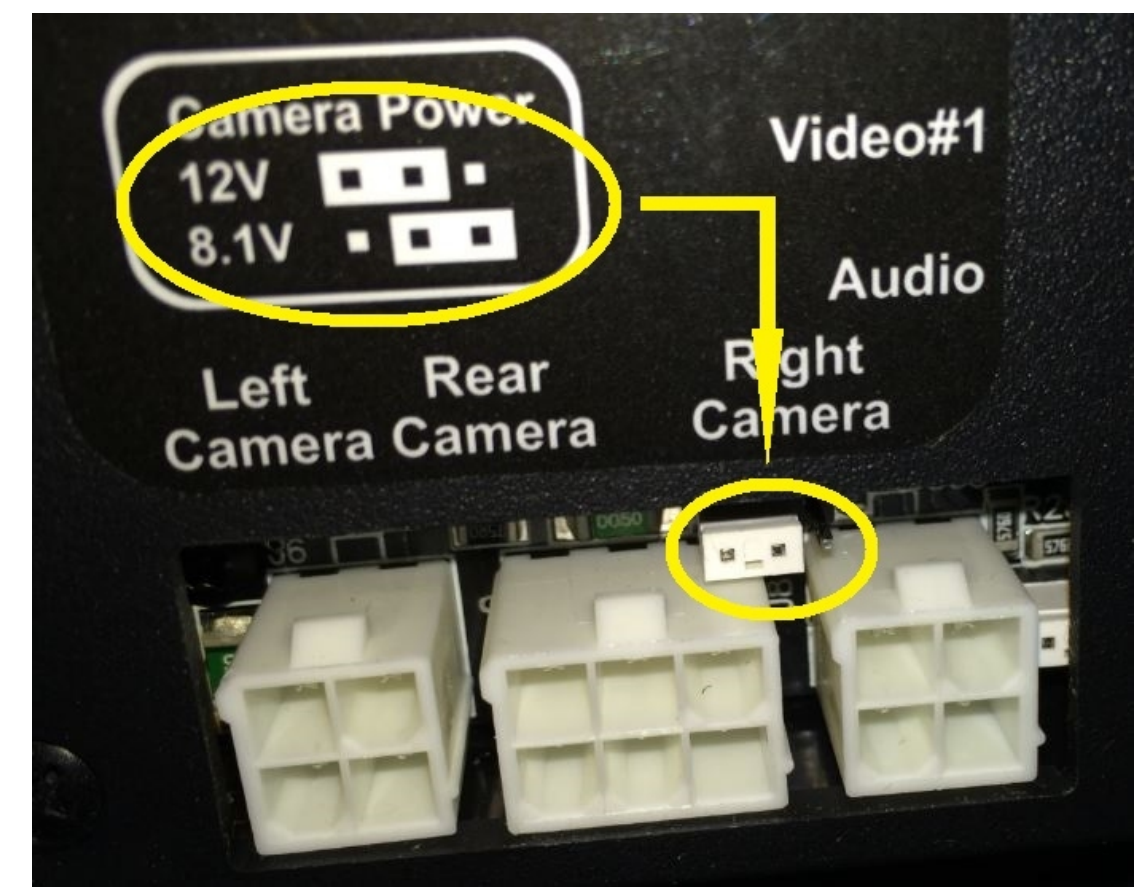
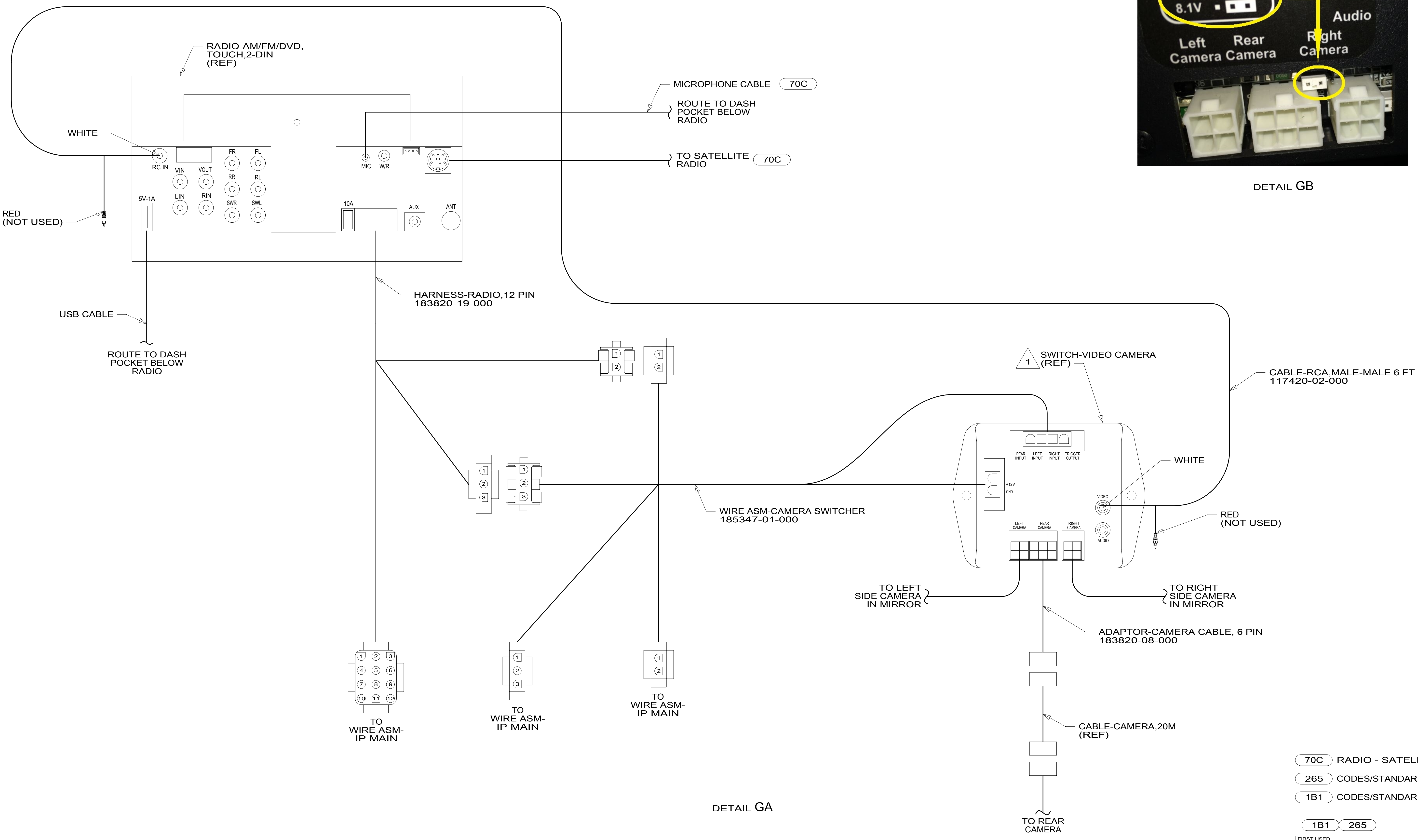

DETAIL GB

DETAIL GA

- 70C RADIO - SATELLITE
- 265 CODES/STANDARDS-CSA/CMVSS
- 1B1 CODES/STANDARDS USA

1B1	265
FIRST USED	
14 D-SERIES	
DO NOT SCALE DRAWING	
TITLE: WIRING INSTL-FRONT END	
SHEET 7	PART NO 185853 REV

FOR ELECTRICAL TORQUE SPECIFICATIONS SEE DWG NO. 128783-01-000

FOR ELECTRICAL CALLOUTS SEE DWG NO. 121339-01-000

NOTES:

185853

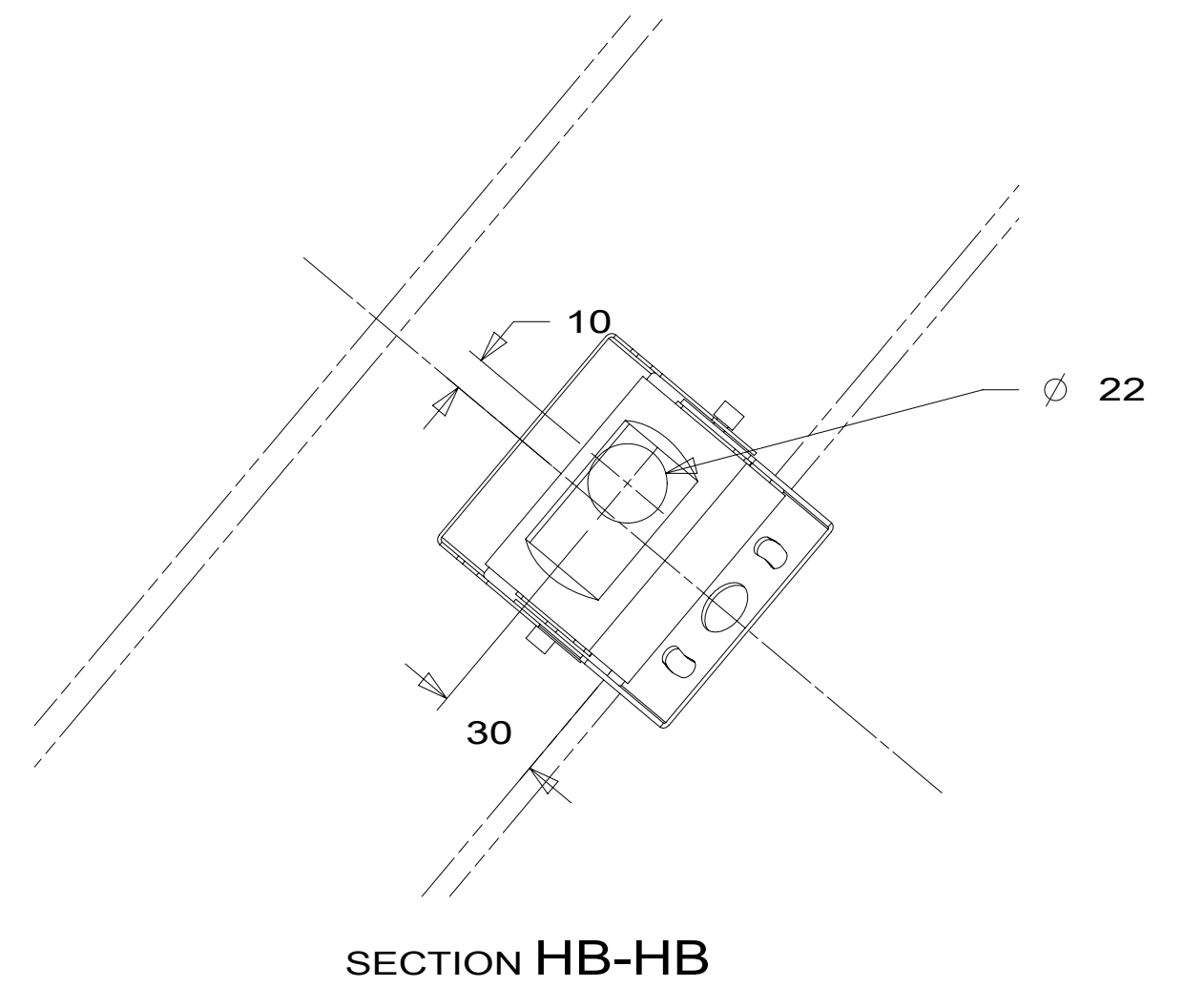
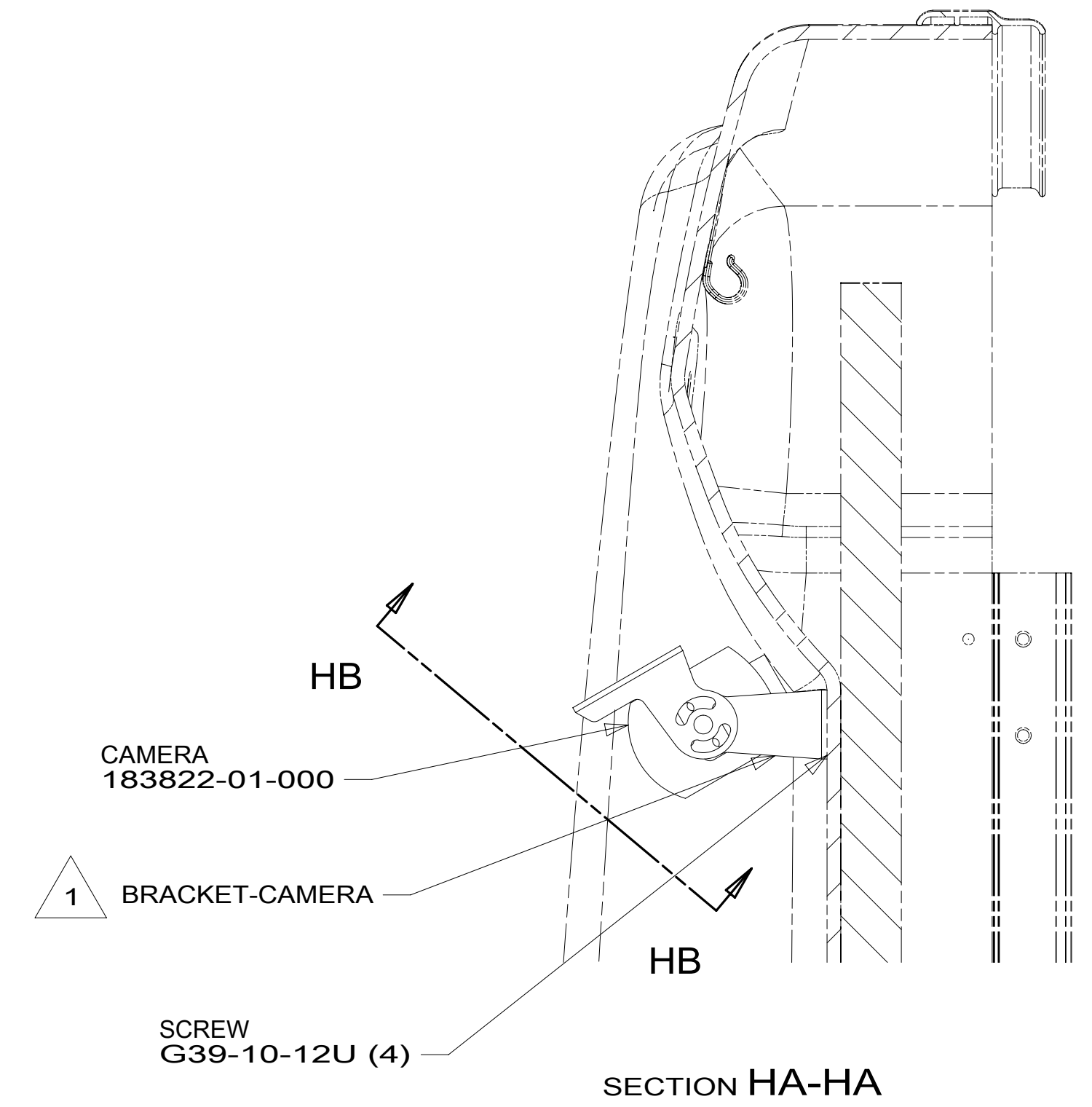
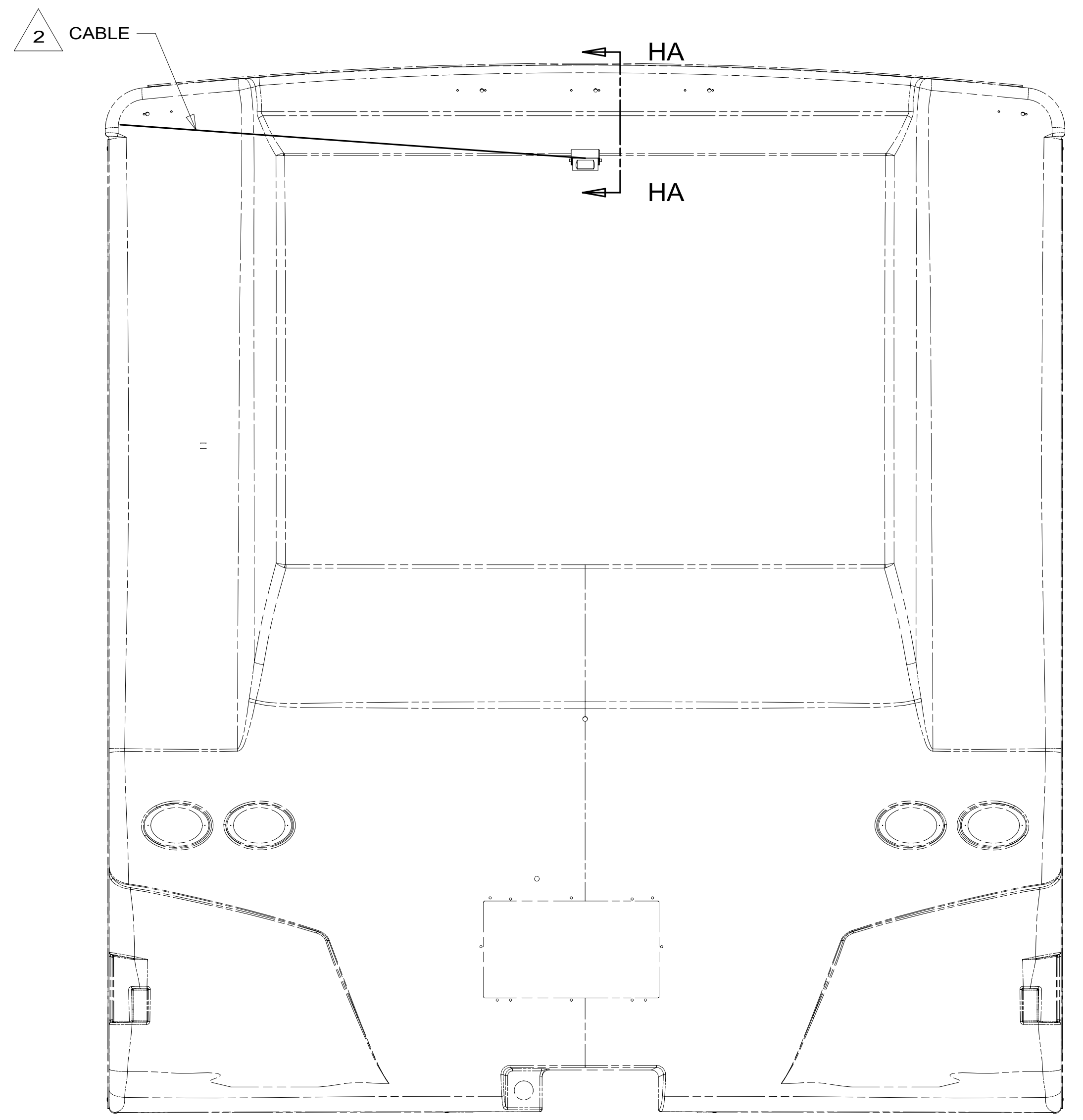
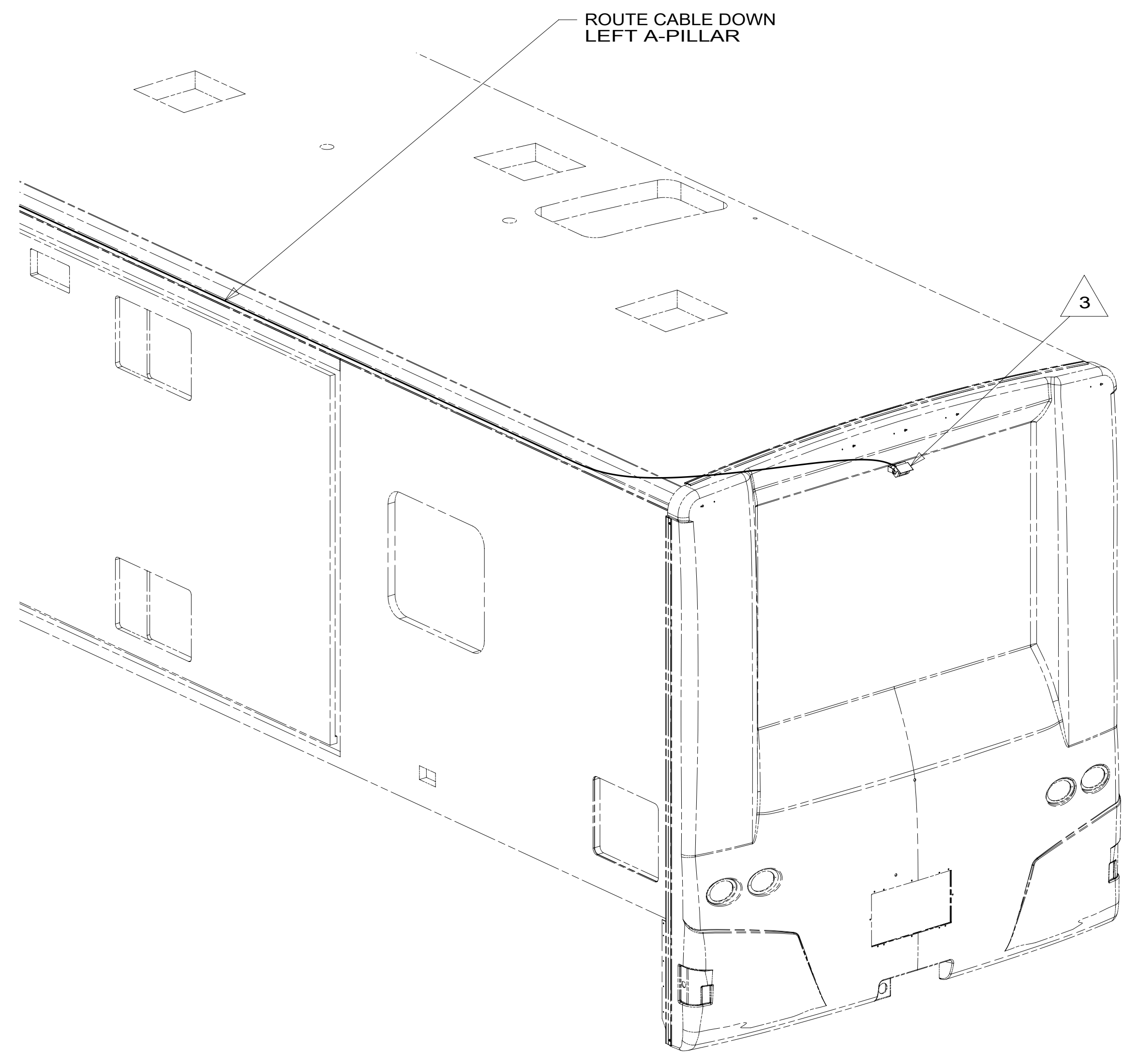

- NOTES:
- 3 ALIGN CAMERA TO CENTER OF BACKWALL AND ADJUST SO BACKWALL IS JUST VISIBLE.
 - 2 RUN CABLE THRU LEFT-HAND COVE TO REAR OF UNIT.
 - 1 PARTS SUPPLIED WITH CAMERA KIT.

- 265 CODES/STANDARDS-CSA/CMVSS
- 1B1 CODES/STANDARDS USA
- 1B1 265

FOR ELECTRICAL TORQUE SPECIFICATIONS SEE DWG NO. 128783-01-000

FOR ELECTRICAL CALLOUTS SEE DWG NO. 121339-01-000

FIRST USED	
14 D-SERIES	
DO NOT SCALE DRAWING	
TITLE: WIRING INSTL-FRONT END	
SHEET 8	PART NO. 185853 REV
1 24-Feb-2015	

*185853 *A

CABLE-MONITOR/CAMERA
183822-02-000

CABLE-SIDE CAMERA
144677-21-000 1

1 CABLE-SIDE CAMERA
144677-21-000

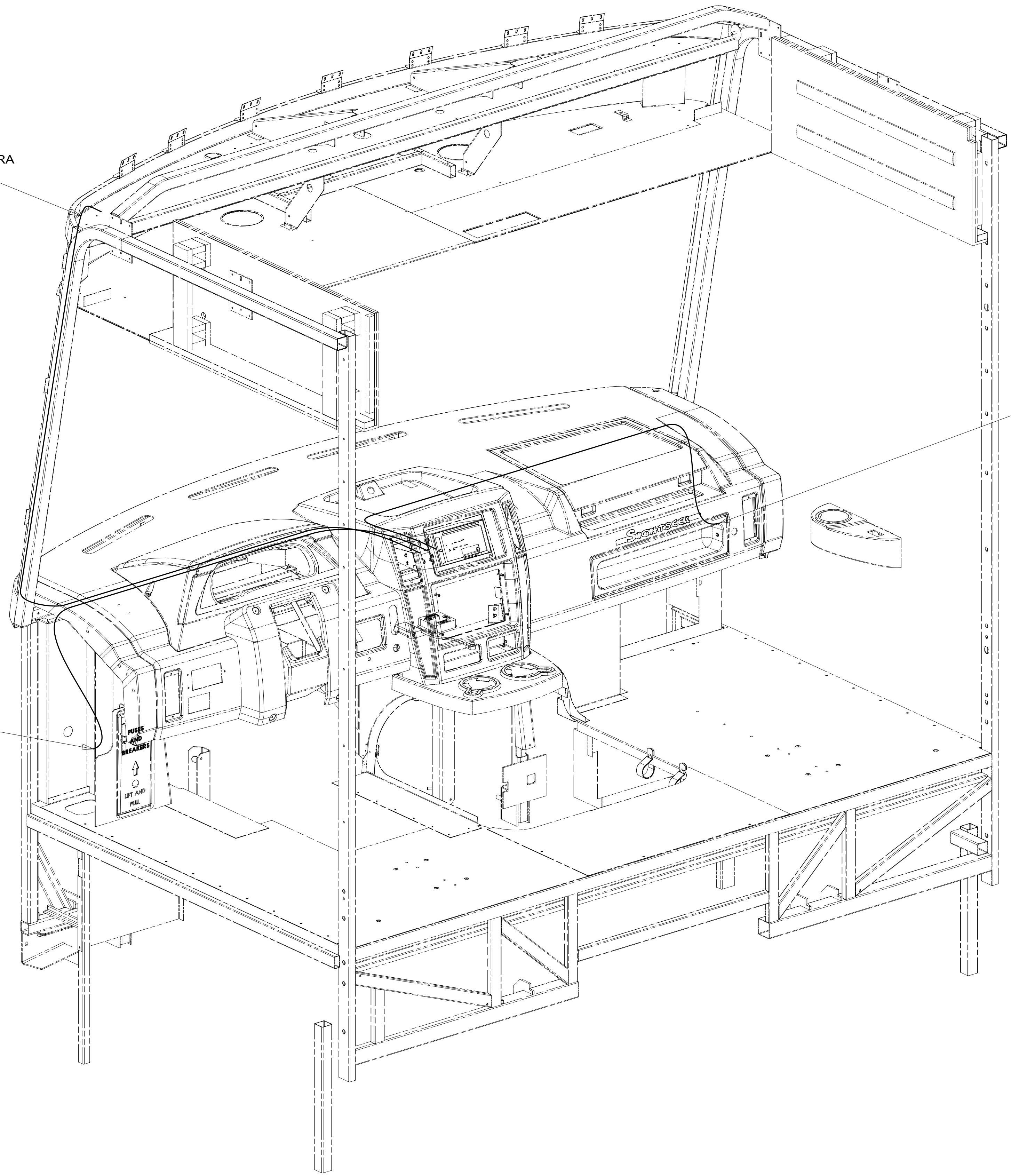

1 CONNECT CAMERA CABLE TO MIRROR.

NOTES:

FOR ELECTRICAL
TORQUE
SPECIFICATIONS
SEE DWG NO.
128783-01-000

X-X
FOR
ELECTRICAL
CALLOUTS
SEE DWG NO.
121339-01-000

265 CODES/STANDARDS-CSA/CMVSS

1B1 CODES/STANDARDS USA

1B1 265

FIRST USED
14 D-SERIES

DO NOT SCALE DRAWING

TITLE: **WIRING INSTL-FRONT END**

SHEET 9 PART NO **185853** REV

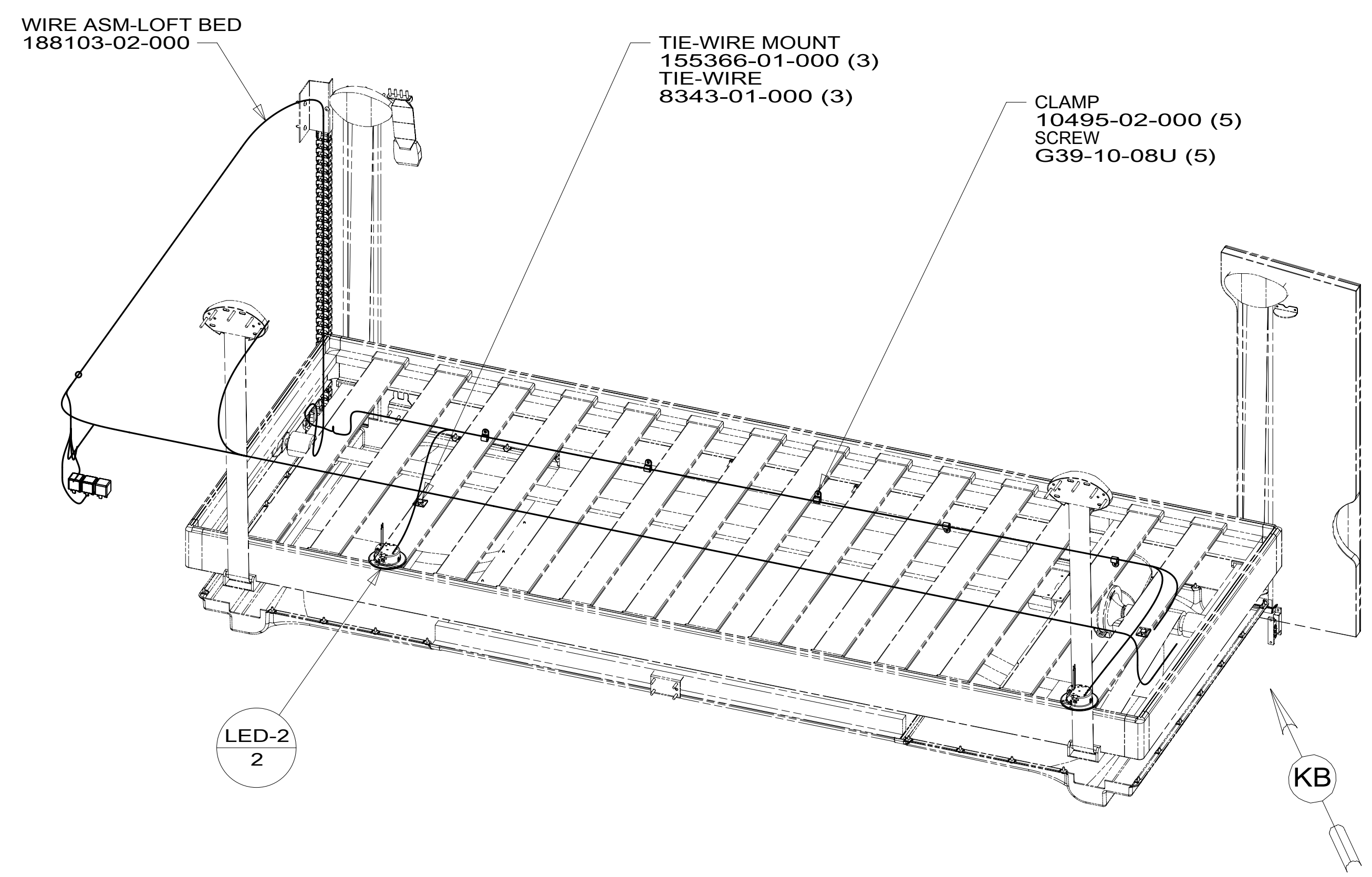

DETAIL KA 45B

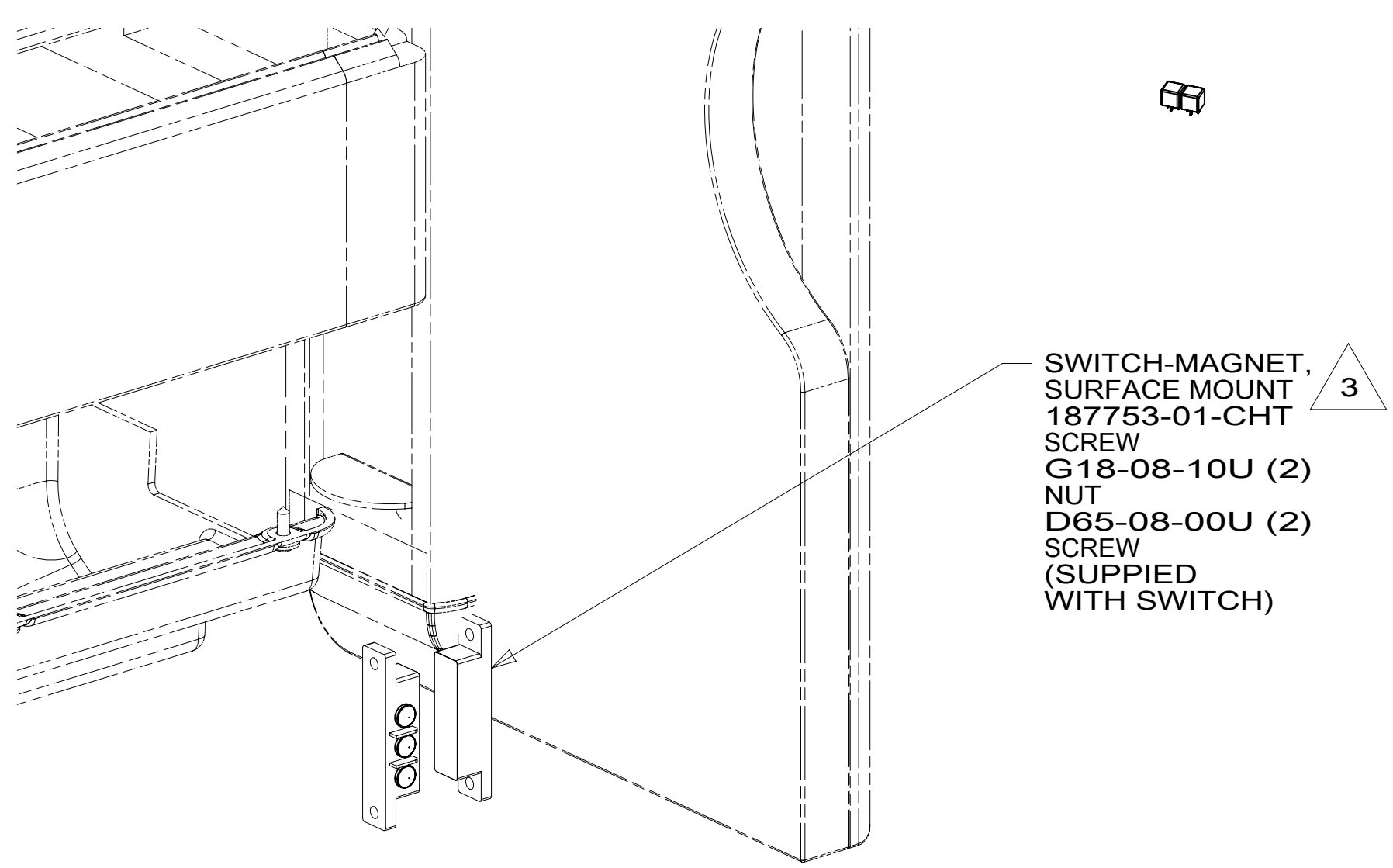

DETAIL KB 45B (SWITCH COVER NOT SHOWN)

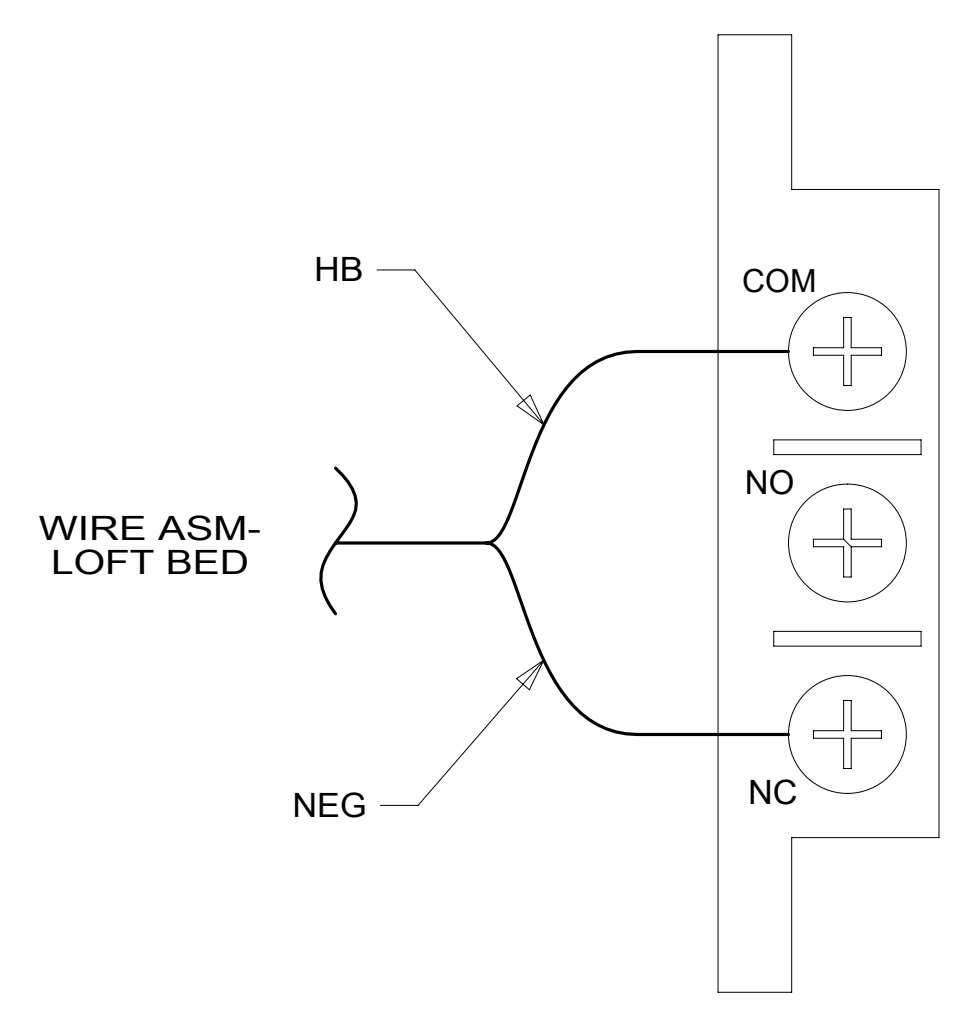

DETAIL KC

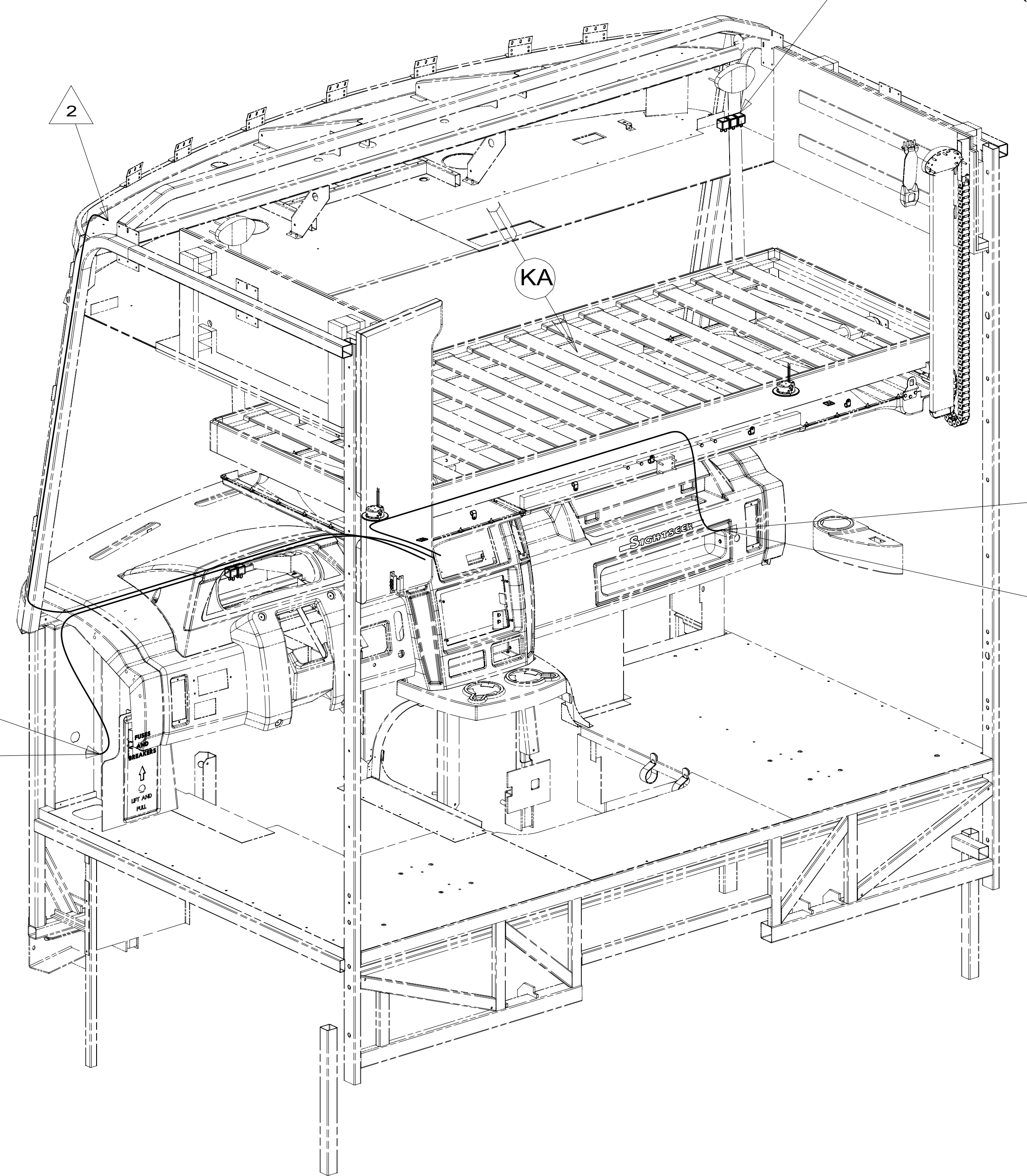

WIRE ASM-MONITOR (REF)

- NOTES:
- 3 SEE DETAIL KC FOR WIRING CONNECTIONS.
 - 2 RUN CABLE THRU LEFT-HAND COVE TO REAR OF UNIT. SEE SHEET 9.
 - 1 CONNECT CAMERA THRU HOLE IN SIDEWALL, PUSH CONNECTOR BACK THRU SIDEWALL, AND SEAL HOLE.

- 45B LOFT BED
- 265 CODES/STANDARDS-CSA/CMVSS
- 1B1 CODES/STANDARDS USA

FIRST USED	
14 D-SERIES	
DO NOT SCALE DRAWING	
TITLE: WIRING INSTL-FRONT END	
SHEET 10	PART NO. 185853 REV
1 24-Feb-2015	

FOR ELECTRICAL TORQUE SPECIFICATIONS SEE DWG NO. 128783-01-000

FOR ELECTRICAL CALLOUTS SEE DWG NO. 121339-01-000

185853