



DANGER

Danger of electrical shock, burns or death. Always remove all power sources before attempting any repair, service or diagnostic work. Power can be present from shore power, generator, inverter or battery. All power sources must be disabled and secured before performing any service.



CAUTION

If you lack the skills, tools or equipment to perform diagnostic or repair work leave such work to an authorized Winnebago Industries dealer or other qualified shop.

DRAWING NO.	FEATURES
185667-01	-----
185667-12	1B1 78J
185667-16	265 78J

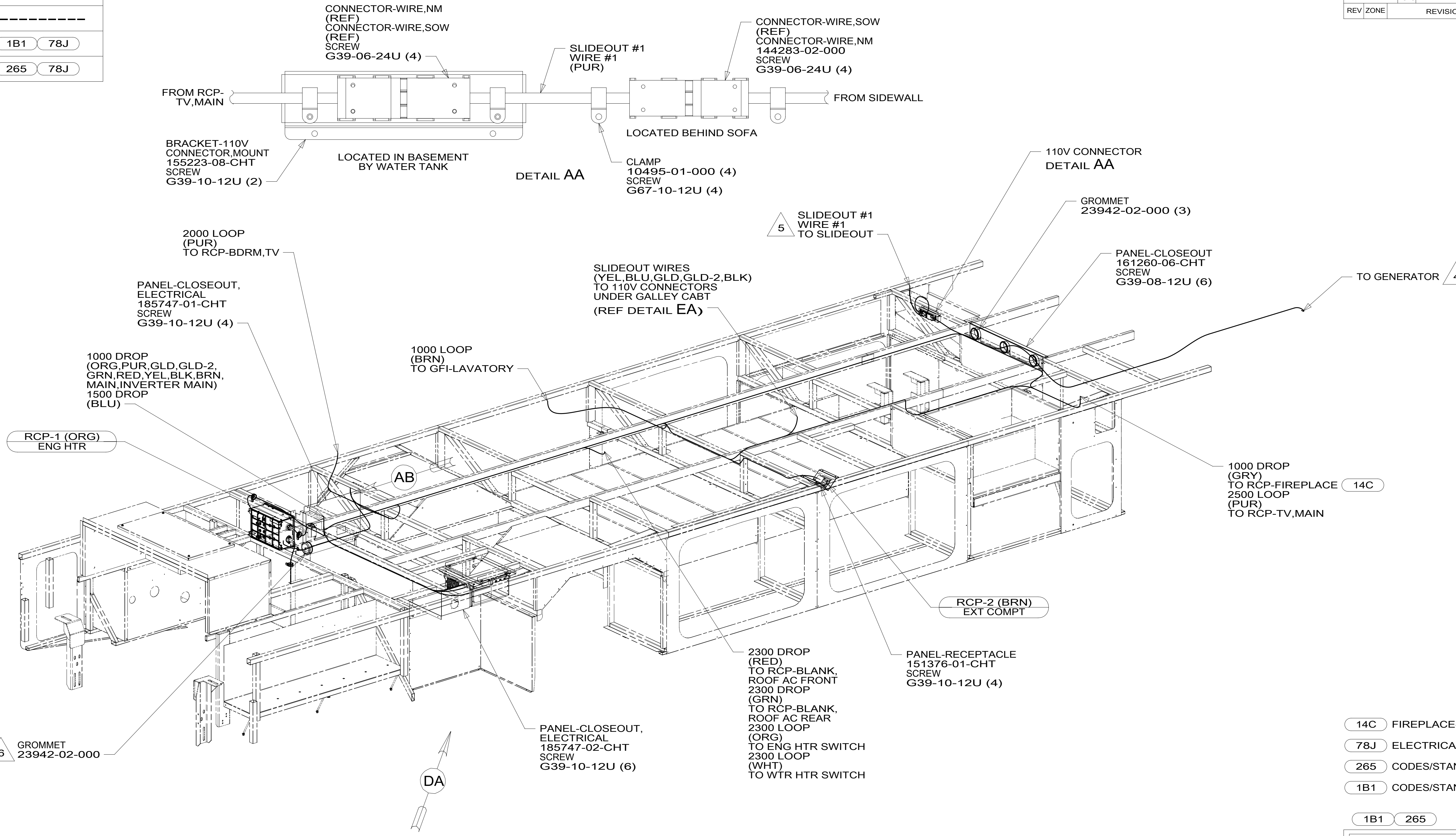

- NOTES:
- 6 ROUTE ENGINE HEATER POWER CORD THROUGH GROMMET.
 - 5 SEE LOAD CENTER/ATS ASM FOR ADDITIONAL INFORMATION.
 - 4 SEE GENERATOR INSTL FOR ADDITIONAL INFORMATION.
 - 3. WIRES THAT REST ON WIRE TRAYS ARE TO BE TIED DOWN WITH WIRE TIE 8343-04-000.
 - 2. CLAMP TO FLOOR SUPPORT TUBES AS NECESSARY WITH CLAMP 10497-01-000.
 - 1. ALL WIRES TO BE SECURED WITH CLAMP 10495 OR 10497 OR WIRE TIE 8343 OR 108046 EVERY 600 MM. USE SCREW G67-XX-XXX OR G56-XX-XXX AS APPROPRIATE FOR INSTALLATION.

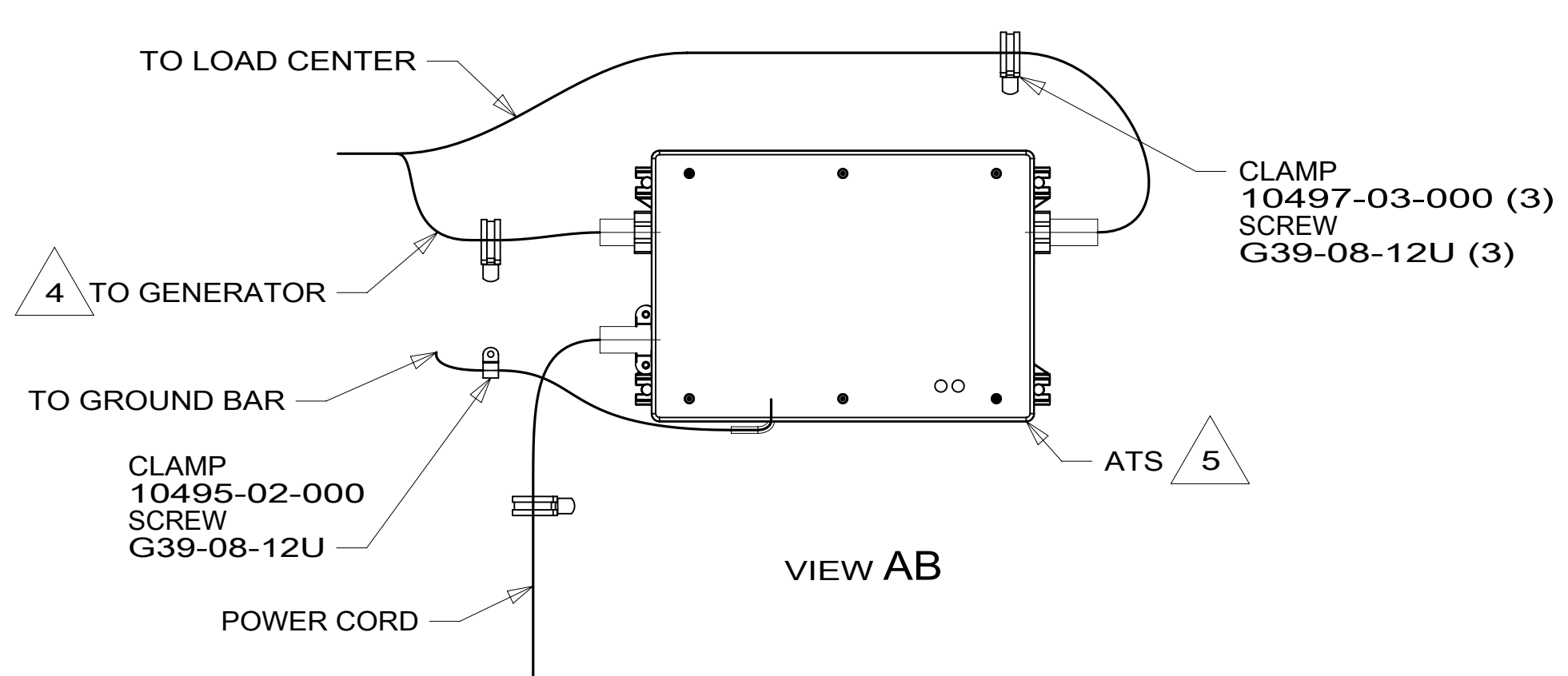

- 14C FIREPLACE-ELECTRIC
- 78J ELECTRICAL SYSTEM-50 AMP
- 265 CODES/STANDARDS-CSA/CMVSS
- 1B1 CODES/STANDARDS USA
- 1B1 265

WINNEBAGO COPYRIGHT 2014 WINNEBAGO INDUSTRIES, INC.

DFTR	ORIG. DATE
CHKR	ALL DIMENSIONS ARE IN MILLIMETERS
P.E.	FIRST USED
M.E.	14 L34T
DSNR	

UNSPECIFIED TOLERANCES ARE:
 WHOLE DIM (X) : 3
 ONE-PLACE (X.X) : 1.5
 TWO-PLACE (X.XX) : 0.50
 ANGLE : 1°

THIRD ANGLE PROJECTION

DO NOT SCALE DRAWING REFER TO ES0018 FOR FASTENER TIGHTENING GUIDELINES

TITLE: **WIRING INSTL-BODY, 110V**

SHEET 1 OF 6 PART NO. 185667 REV. 1 09-Oct-2015

FOR ELECTRICAL TORQUE SPECIFICATIONS SEE DWG NO. 128783-01-000

FOR ELECTRICAL CALLOUTS SEE DWG NO. 121339-01-000

185667

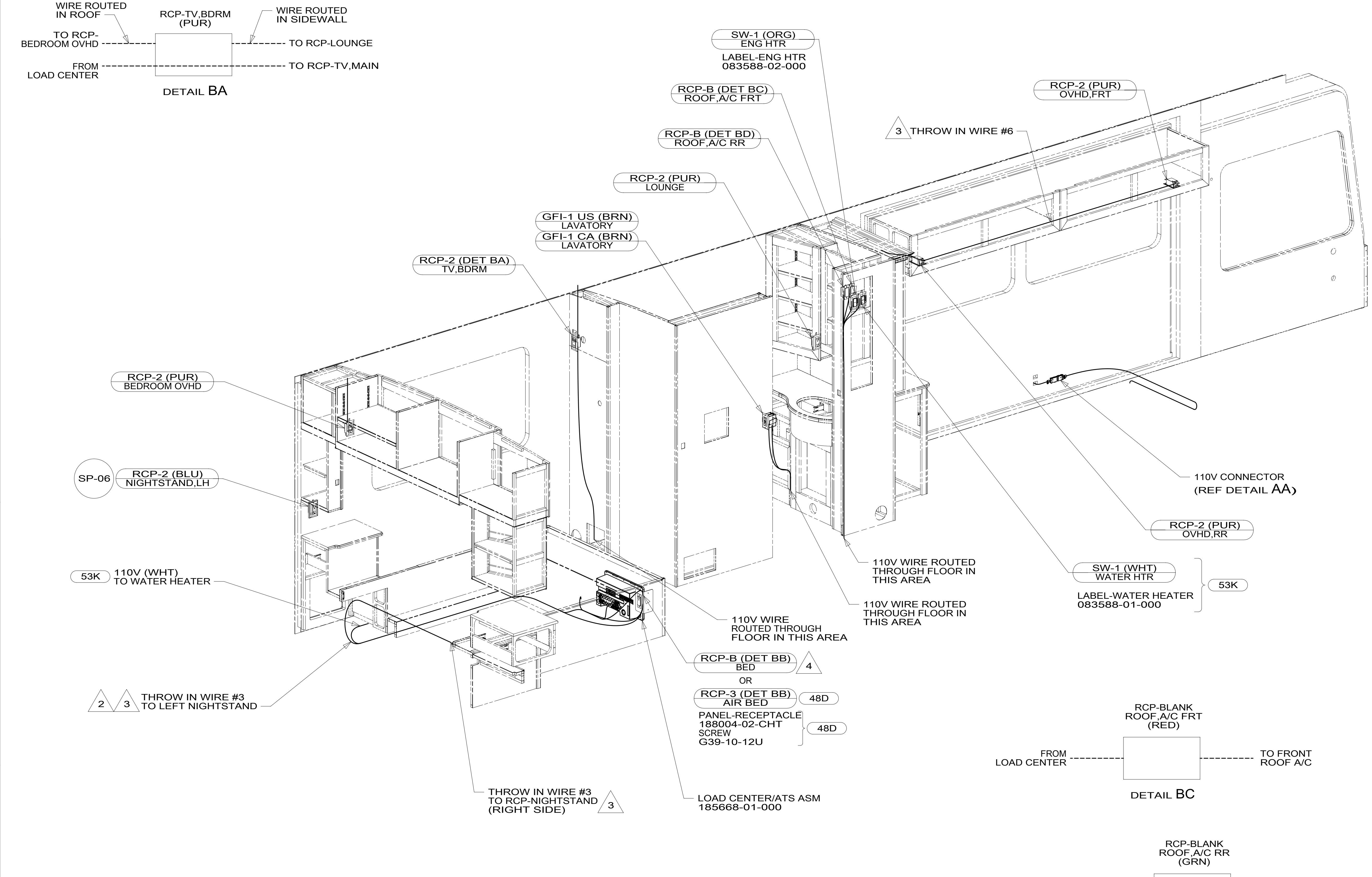

- 4 WITHOUT 48D
- 3 SEE LOAD CENTER/ATS ASM FOR ADDITIONAL INFORMATION.
- 2 PUSH WIRE THROUGH ROUTED PATH IN SIDEWALL.
1. ALL WIRES TO BE SECURED WITH CLAMP 10495 OR 10497 OR WIRE TIE 8343 OR 108046 EVERY 600 MM. USE SCREW G67-XX-XXX OR G56-XX-XXX AS APPROPRIATE FOR INSTALLATION.



53K	WTR HTR-10GAL/ELECTRIC/LPGAS
48D	BED-QUEEN, AIR SLEEP SYSTEM
265	CODES/STANDARDS-CSA/CMVSS
1B1	CODES/STANDARDS USA
1B1	265
FIRST USED	
14 L34T	
DO NOT SCALE DRAWING	
TITLE: WIRING INSTL-BODY, 110V	
SHEET 2	PART NO 185667 REV
1 09-Oct-2015	

FOR ELECTRICAL TORQUE SPECIFICATIONS SEE DWG NO. 128783-01-000

X-X FOR ELECTRICAL CALLOUTS SEE DWG NO. 121339-01-000

185667

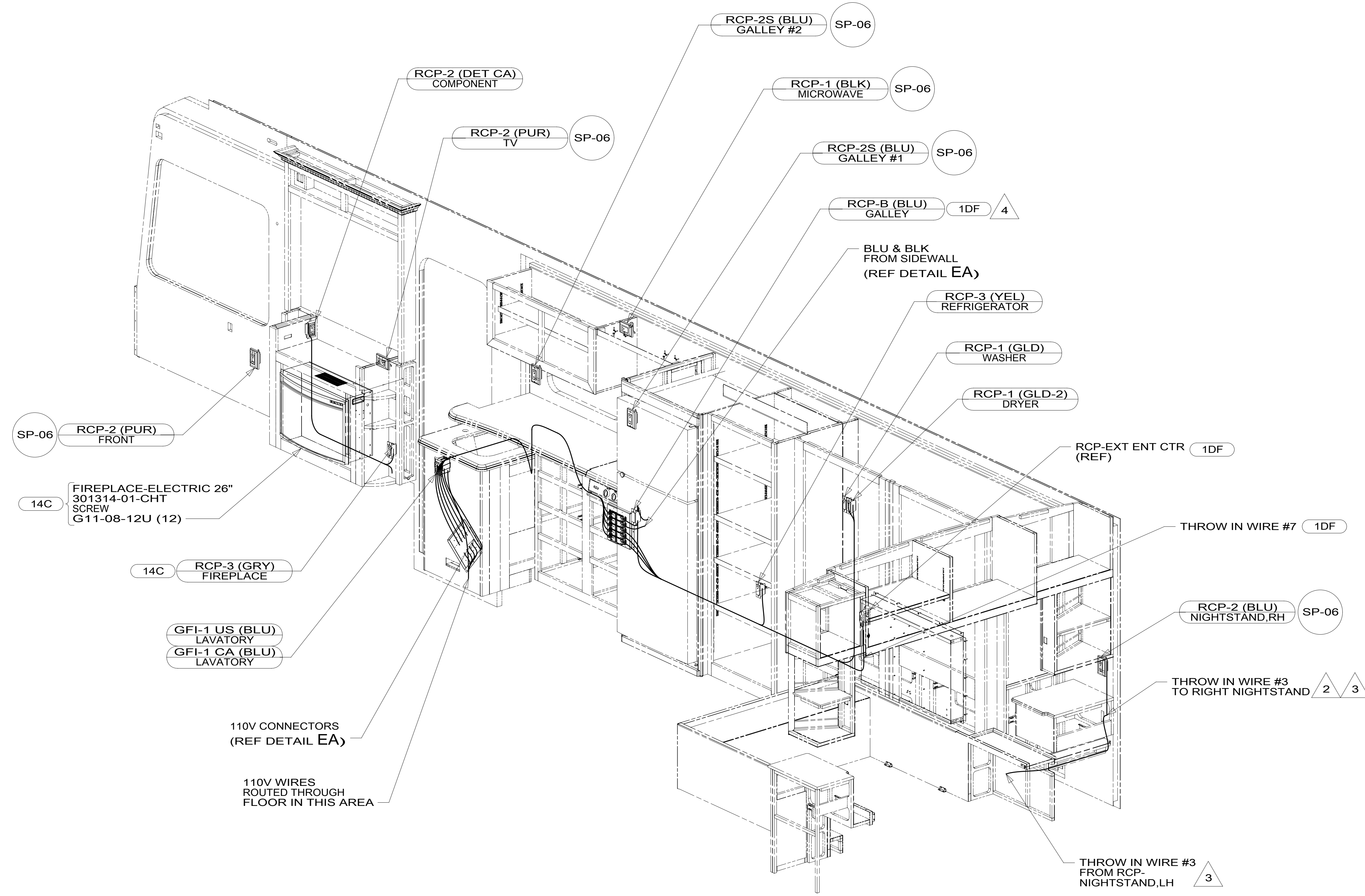

110V CONNECTORS
(REF DETAIL EA)

110V WIRES
ROUTED THROUGH
FLOOR IN THIS AREA

- 4 ADD BLANK RCP IN-LINE WITH BLUE CIRCUIT FROM SIDEWALL TO FEED EXT ENT CTR RCP WITH 1DF
- 3 SEE LOAD CENTER/ATS ASM FOR ADDITIONAL INFORMATION.
- 2 PUSH WIRE THROUGH ROUTED PATH IN SIDEWALL.
1. ALL WIRES TO BE SECURED WITH CLAMP 10495 OR 10497 OR WIRE TIE 8343 OR 108046 EVERY 600 MM. USE SCREW G67-XX-XXX OR G56-XX-XXX AS APPROPRIATE FOR INSTALLATION.

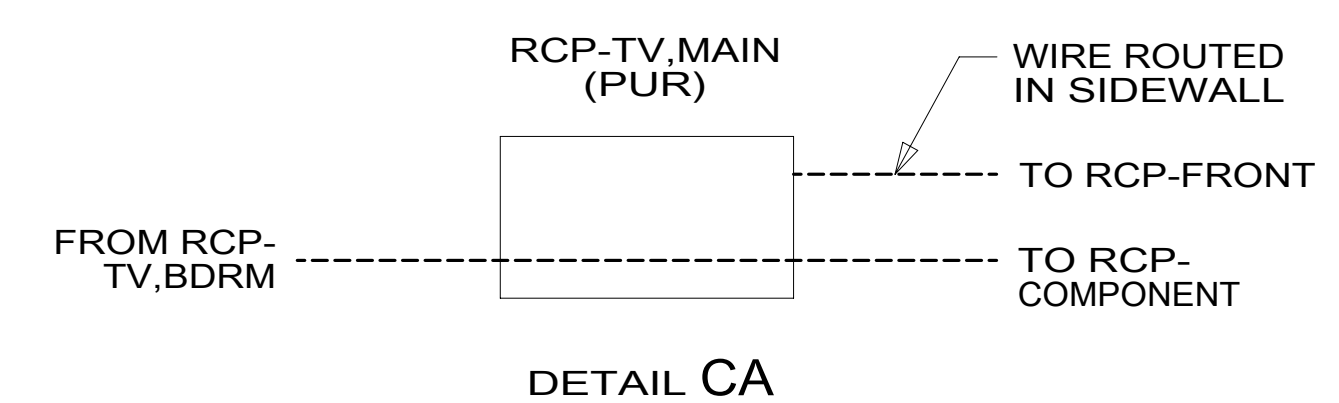

FOR ELECTRICAL TORQUE SPECIFICATIONS SEE DWG NO. 128783-01-000

FOR ELECTRICAL CALLOUTS SEE DWG NO. 121339-01-000

- 1DF EXT TV ENTERTAINMENT CENTER
- 14C FIREPLACE-ELECTRIC
- 265 CODES/STANDARDS-CSA/CMVSS
- 1B1 CODES/STANDARDS USA

FIRST USED	
14 L34T	
DO NOT SCALE DRAWING	
WIRING INSTL-BODY, 110V	
SHEET 3	PART NO 185667 REV
1 09-Oct-2015	

185667

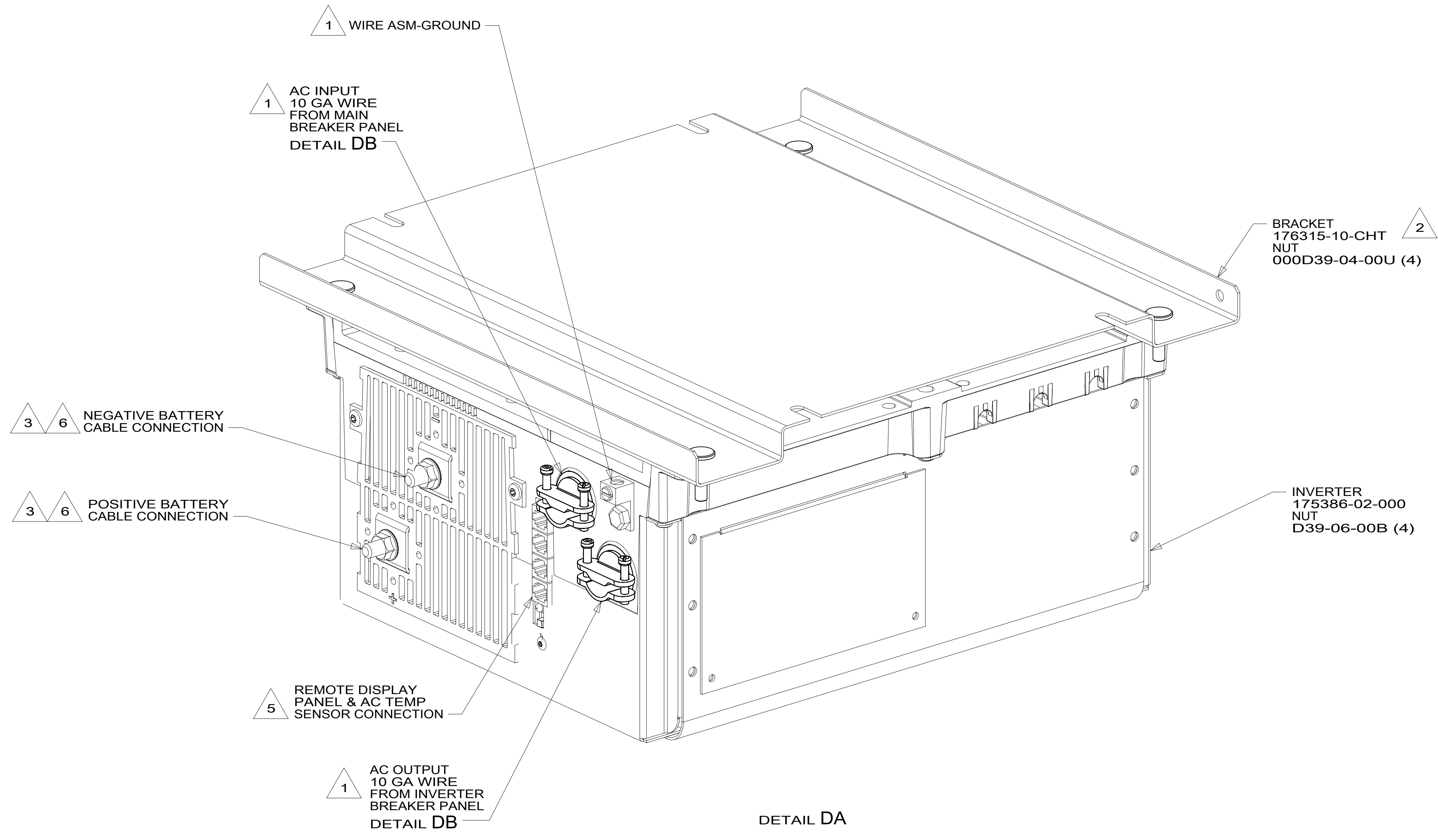

DETAIL DA

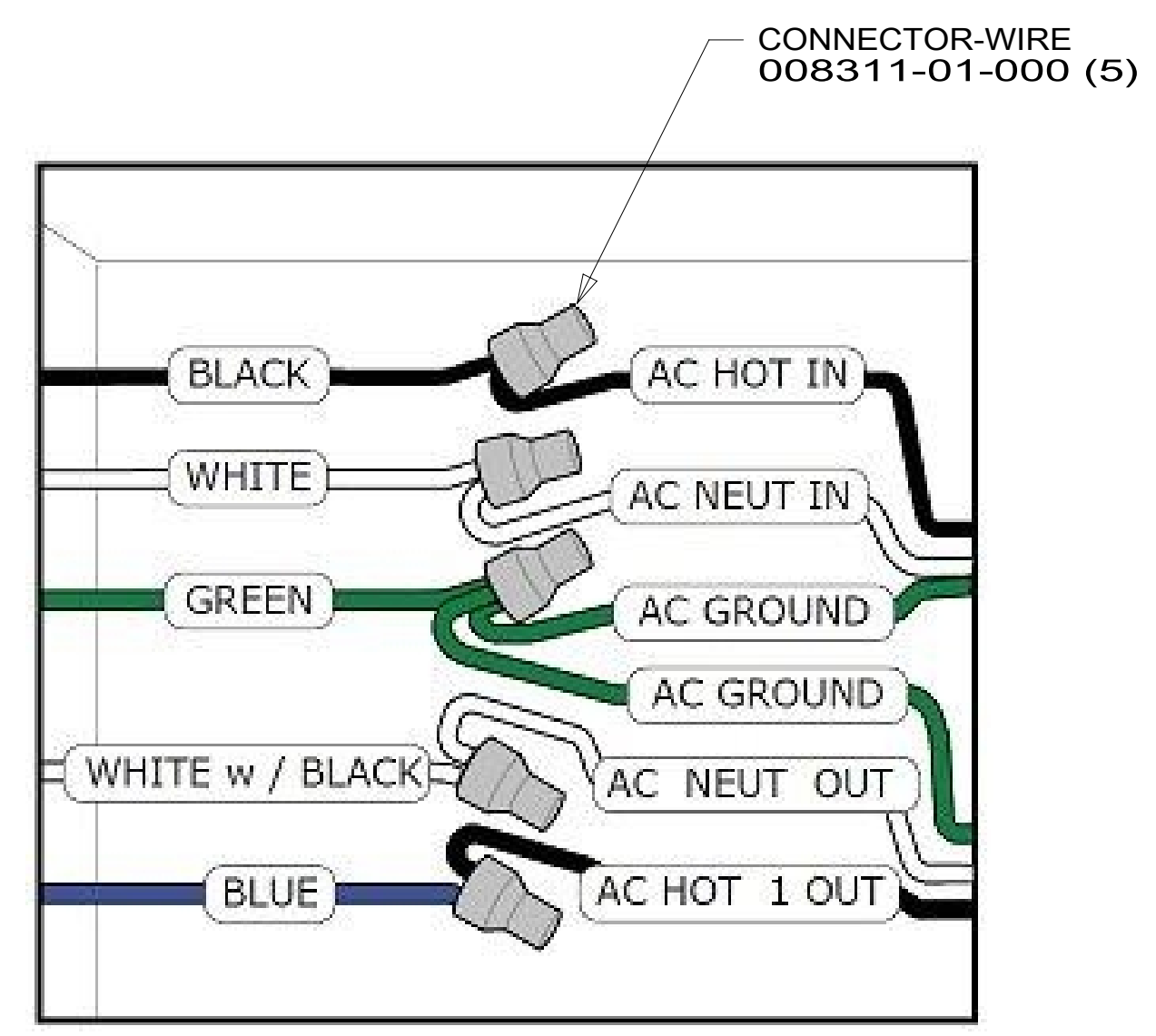

DETAIL DB

- NOTES:
- 6 DO NOT USE POWER/AIR TOOL TO INSTALL NUT. TORQUE TO 10-12 FT LBS.
 - 5 CABLES PART OF WIRE ASM-COACH.
 - 4 SEE INVERTER/CHARGER OWNER'S MANUAL FOR ADDITIONAL INFORMATION.
 - 3 SEE WIRING INSTL-CHASSIS FOR ADDITIONAL INFORMATION.
 - 2 BRACKET IS LOCATED BY HOLES ON BRACKET.
 - 1 SEE LOAD CENTER/ATS ASM FOR ADDITIONAL INFORMATION.

FOR ELECTRICAL TORQUE SPECIFICATIONS SEE DWG NO. 128783-01-000

FOR ELECTRICAL CALLOUTS SEE DWG NO. 121339-01-000

- 265 CODES/STANDARDS-CSA/CMVSS
- 1B1 CODES/STANDARDS USA
- 1B1 265

FIRST USED		14 L34T	
DO NOT SCALE DRAWING			
TITLE: WIRING INSTL-BODY, 110V			
SHEET 4	PART NO	185667	REV
			1 09-Oct-2015

185667

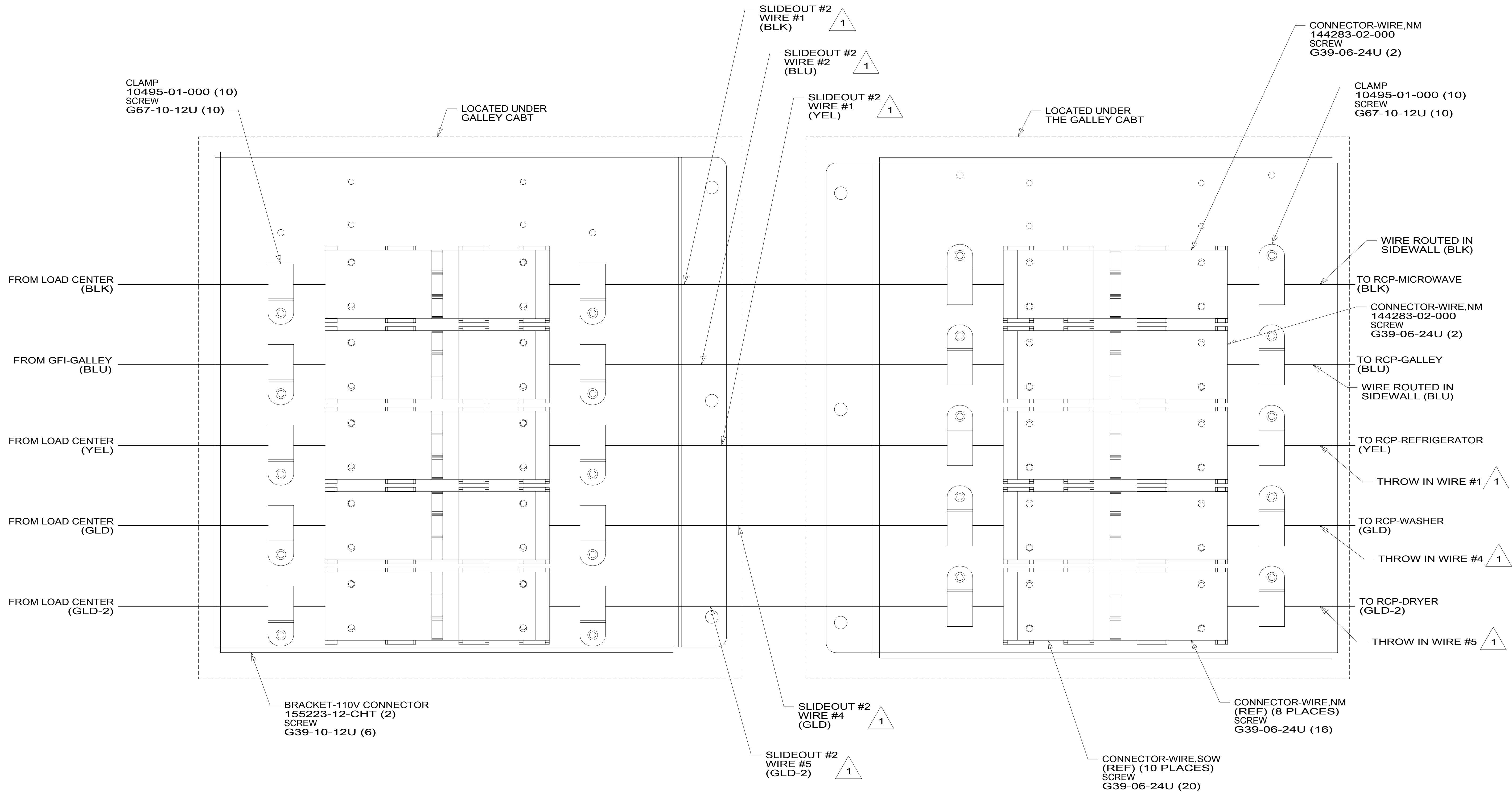

DETAIL EA

1 SEE LOAD CENTER/ATS ASM FOR ADDITIONAL INFORMATION.
NOTES:

FOR ELECTRICAL TORQUE SPECIFICATIONS SEE DWG NO. 128783-01-000

FOR ELECTRICAL CALLOUTS SEE DWG NO. 121339-01-000

265 CODES/STANDARDS-CSA/CMVSS
1B1 CODES/STANDARDS USA

1B1 265

FIRST USED	
14 L34T	
DO NOT SCALE DRAWING	
TITLE: WIRING INSTL-BODY, 110V	
SHEET 5	PART NO 185667 REV

* 185667 *

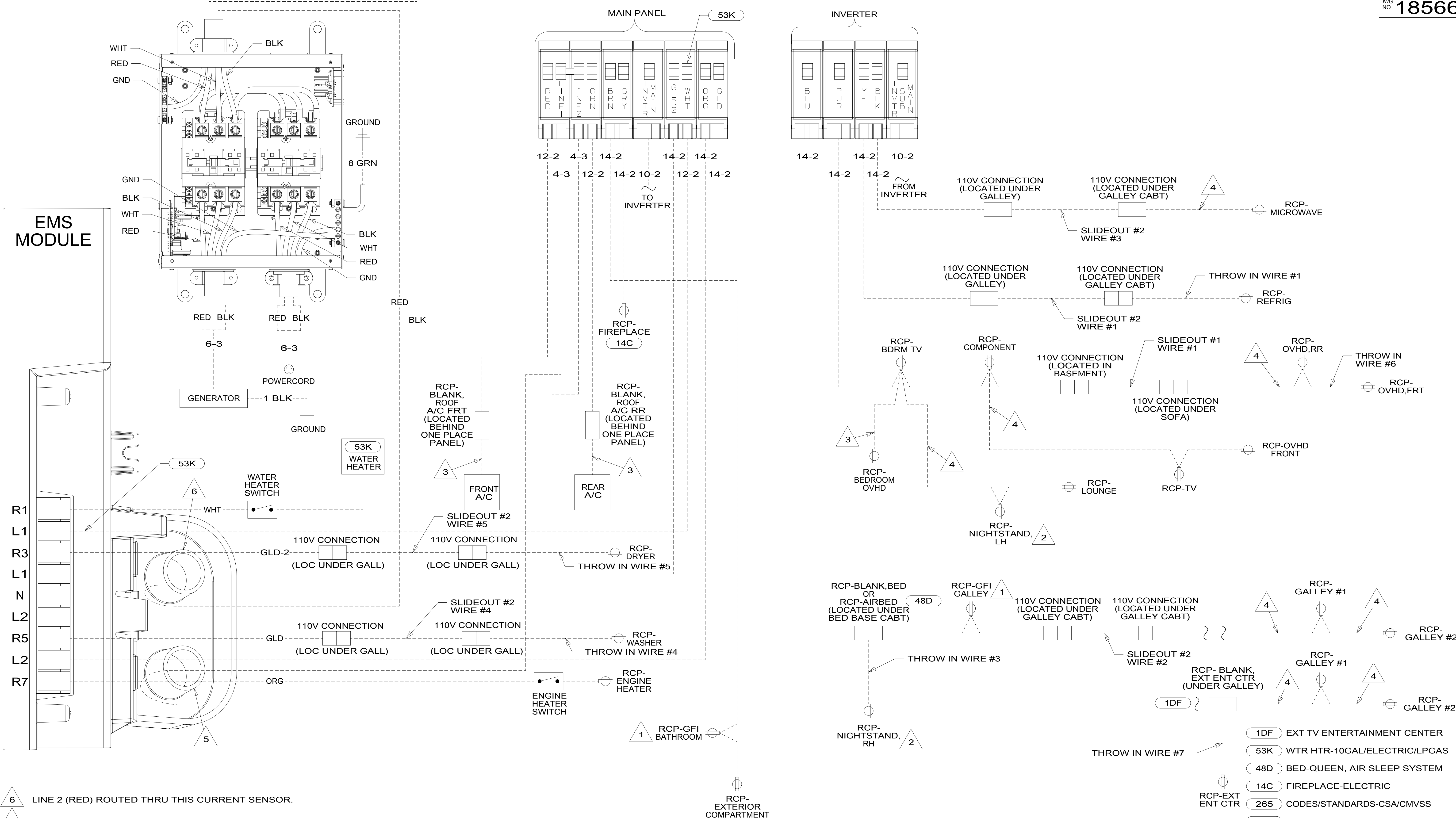

- NOTES:
- 6 LINE 2 (RED) ROUTED THRU THIS CURRENT SENSOR.
 - 5 LINE 1 (BLK) ROUTED THRU THIS CURRENT SENSOR.
 - 4 WIRE ROUTED IN SIDEWALL.
 - 3 WIRE ROUTED IN ROOF.
 - 2 WIRE IS PUSHED THROUGH SIDEWALL TO RECEPTACLE.
 - 1 ALL OUTLETS DOWN STREAM AND INCLUDING THIS OUTLET ARE GROUND FAULT INTERRUPT PROTECTED.

- 1DF EXT TV ENTERTAINMENT CENTER
- 53K WTR HTR-10GAL/ELECTRIC/LPGAS
- 48D BED-QUEEN, AIR SLEEP SYSTEM
- 14C FIREPLACE-ELECTRIC
- 265 CODES/STANDARDS-CSA/CMVSS
- 1B1 CODES/STANDARDS USA

FIRST USED	
14 L34T	
DO NOT SCALE DRAWING	
TITLE: WIRING INSTL-BODY, 110V	
SHEET 6	PART NO 185667 REV
1 09-Oct-2015	

FOR ELECTRICAL TORQUE SPECIFICATIONS SEE DWG NO. 128783-01-000

FOR ELECTRICAL CALLOUTS SEE DWG NO. 121339-01-000

* 185667 *