



DANGER

Danger of electrical shock, burns or death. Always remove all power sources before attempting any repair, service or diagnostic work. Power can be present from shore power, generator, inverter or battery. All power sources must be disabled and secured before performing any service.



CAUTION

If you lack the skills, tools or equipment to perform diagnostic or repair work leave such work to an authorized Winnebago Industries dealer or other qualified shop.

DRAWING NO.	MODEL
185576-01	L34T
185576-02	L38R

RELEASE	REV/DATE	DWG NO	185576
REV ZONE	REVISION RECORD	DATE	DFT-ORIG

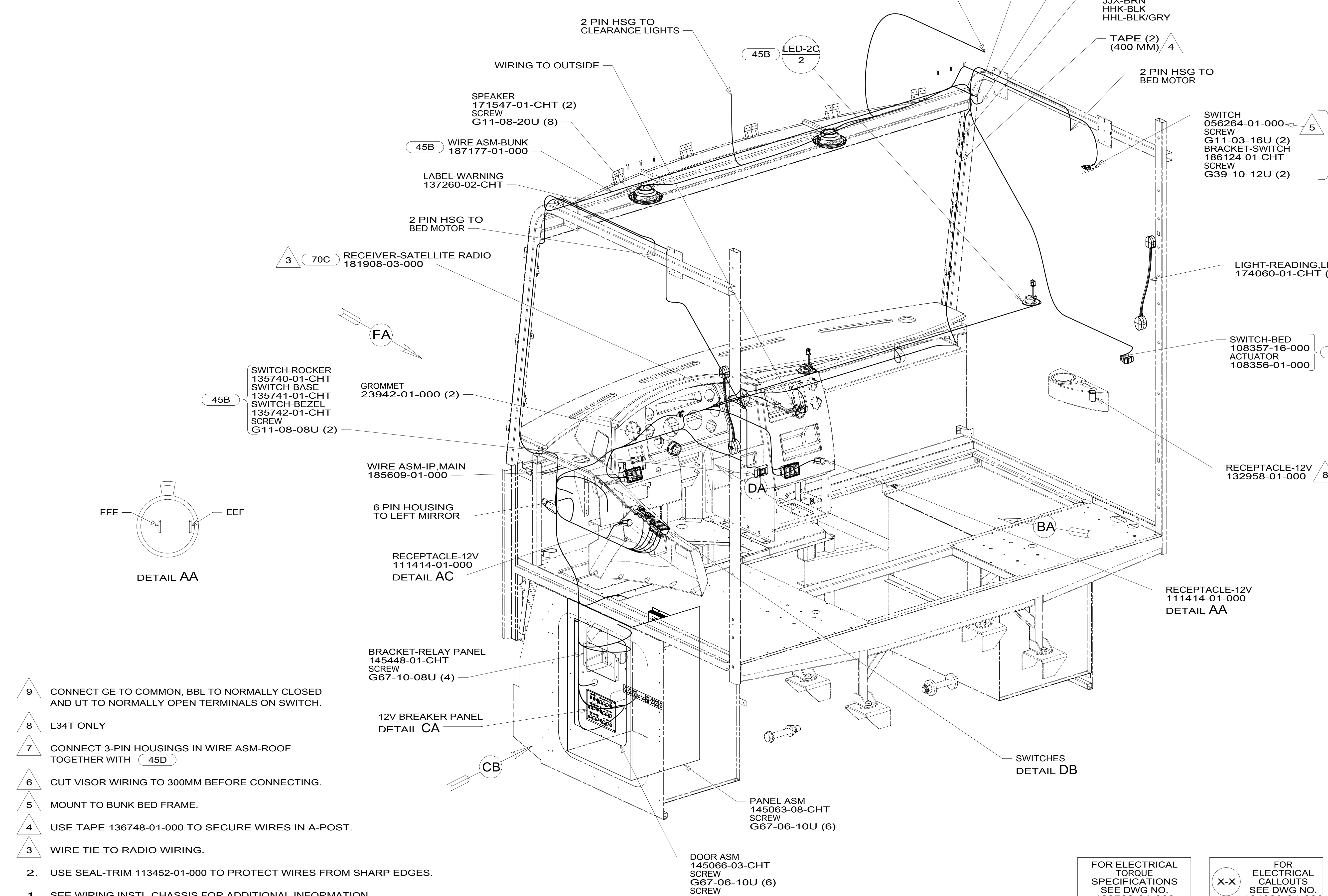

- NOTES:
- SEE WIRING INSTL-CHASSIS FOR ADDITIONAL INFORMATION.
 - USE SEAL-TRIM 113452-01-000 TO PROTECT WIRES FROM SHARP EDGES.
- 9 CONNECT GE TO COMMON, BBL TO NORMALLY CLOSED AND UT TO NORMALLY OPEN TERMINALS ON SWITCH.
- 8 L34T ONLY
- 7 CONNECT 3-PIN HOUSINGS IN WIRE ASM-ROOF TOGETHER WITH (45D)
- 6 CUT VISOR WIRING TO 300MM BEFORE CONNECTING.
- 5 MOUNT TO BUNK BED FRAME.
- 4 USE TAPE 136748-01-000 TO SECURE WIRES IN A-POST.
- 3 WIRE TIE TO RADIO WIRING.

- (70C) RADIO - SATELLITE
 - (45D) LOFT BED - WITHOUT
 - (45B) LOFT BED
 - (265) CODES/STANDARDS-CSA/CMVSS
 - (1B1) CODES/STANDARDS USA
- (1B1) (265)

		COPYRIGHT 2014 WINNEBAGO INDUSTRIES, INC.
DFT-ORIG	ORIG. DATE	
CHKR	ALL DIMENSIONS ARE IN MILLIMETERS	
P.E.		
M.E.	FIRST USED	
DSNR	14 L-SERIES	
UNSPECIFIED TOLERANCES ARE:		MATERIAL:
WHOLE DIM (X)	:	
ONE-PLACE (X.X)	:	
TWO-PLACE (X.XX)	:	
ANGLE	:	
THIRD ANGLE PROJECTION		
DO NOT SCALE DRAWING	REFER TO ES0018 FOR FASTENER TIGHTENING GUIDELINES	
TITLE: WIRING INSTL-FRONT END		
SHEET 1 OF 9	PART NO 185576	REV
REF:	1	30-Dec-2014

FOR ELECTRICAL TORQUE SPECIFICATIONS SEE DWG NO. 128783-01-000

FOR ELECTRICAL CALLOUTS SEE DWG NO. 121339-01-000

185576

WIRE ASM-IP,MAIN

LABEL-CB PREP OPTION
104678-01-000

CB POWER PROVISION
YELLOW +12V
WHITE GROUND
COAX ANTENNA
(SEE REVERSE SIDE ALSO)

WHT YEL
TO CUSTOMERS
CB RADIO

DETAIL BB 579

1 2 PIN HOUSING
(2) BUTT SPLICES

RING TERMINALS
TO GROUND STUD

(2) BUTT SPLICES
TO CB PREP
DETAIL BB

TO WIRE ASM-RADIO
DETAIL JA

2 & 6 PIN HOUSINGS
TO LEFT MIRROR

BUTT SPLICE
SPADE TERMINAL
TO 12V RCP

TO SWITCHES
DETAIL DB

2 & 6 PIN HOUSINGS
TO HEATER/AC CONTROLS

TO SWITCHES

DETAIL BA

- 579 RADIO - CB WIRE PREP
- 265 CODES/STANDARDS-CSA/CMVSS
- 1B1 CODES/STANDARDS USA

1B1 265

FIRST USED
14 L-SERIES

DO NOT SCALE DRAWING

TITLE: **WIRING INSTL-FRONT END**

SHEET 2 PART NO **185576** REV

1 30-Dec-2014

2 EDGE OF LABEL TO HANG JUST BELOW BOTTOM OF DASH.

1 ROUTE WIRES UP LEFT A-PILLAR.

NOTES:

FOR ELECTRICAL
TORQUE
SPECIFICATIONS
SEE DWG NO.
128783-01-000

X-X
FOR
ELECTRICAL
CALLOUTS
SEE DWG NO.
121339-01-000

*185576 *A

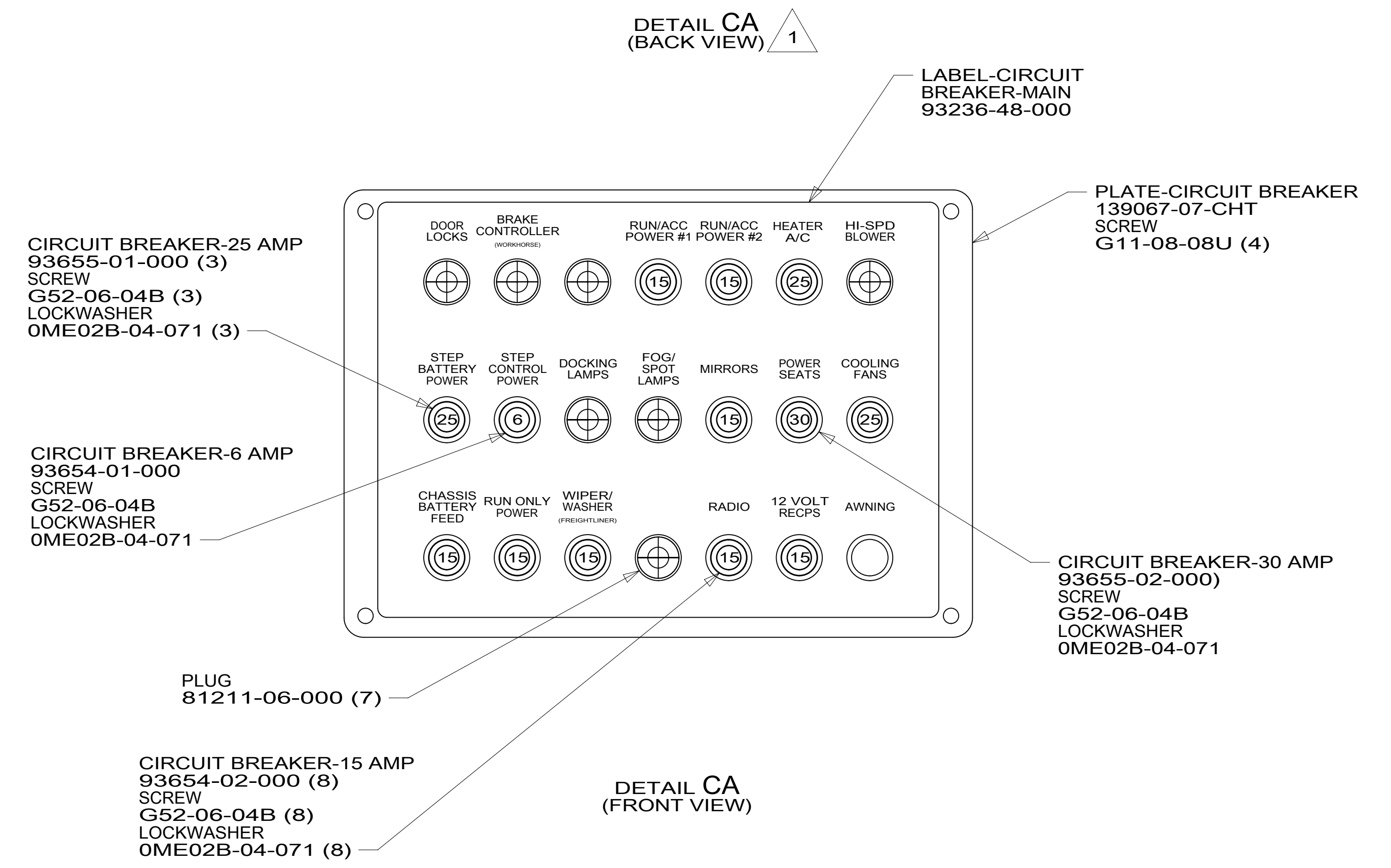
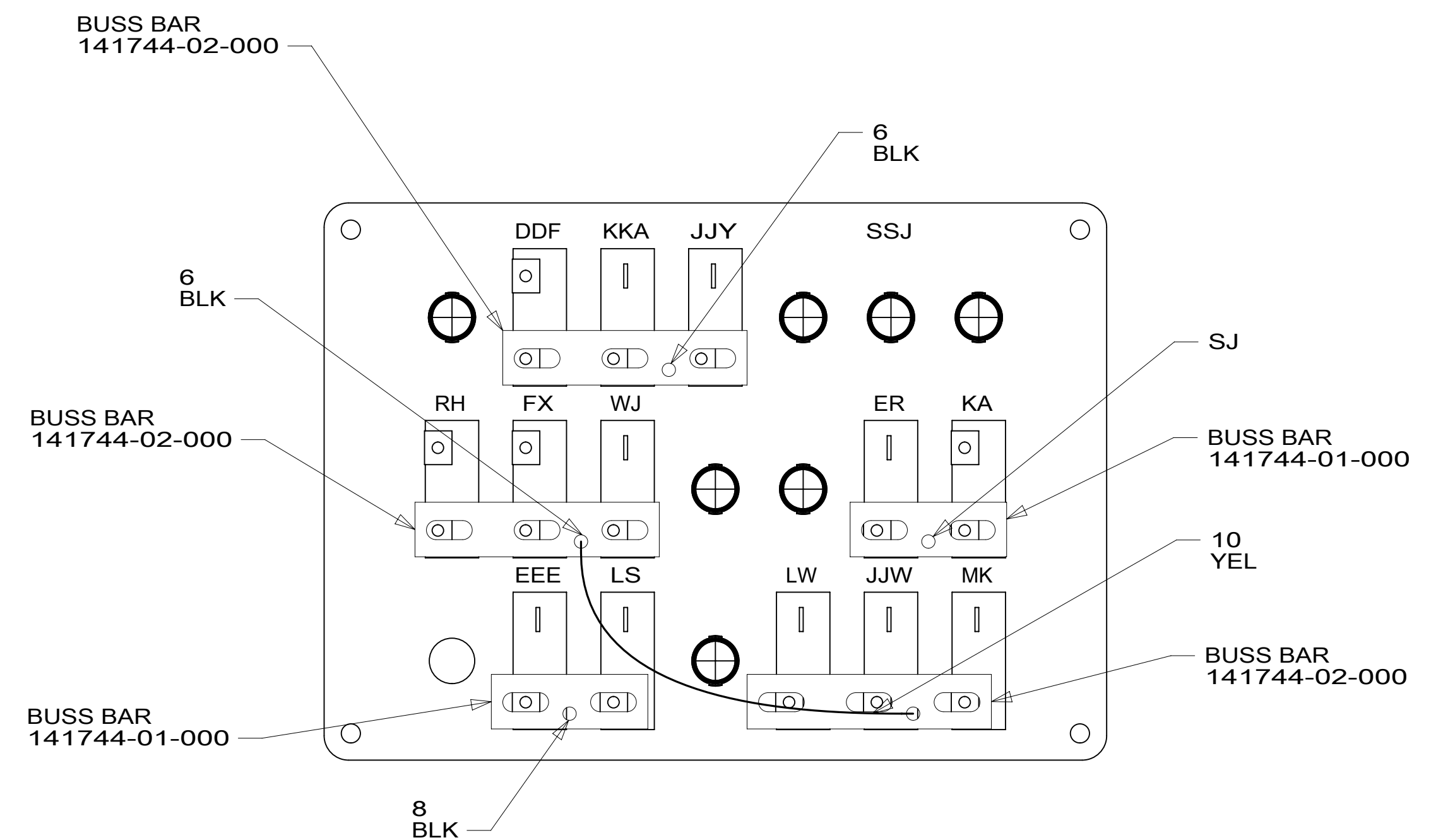
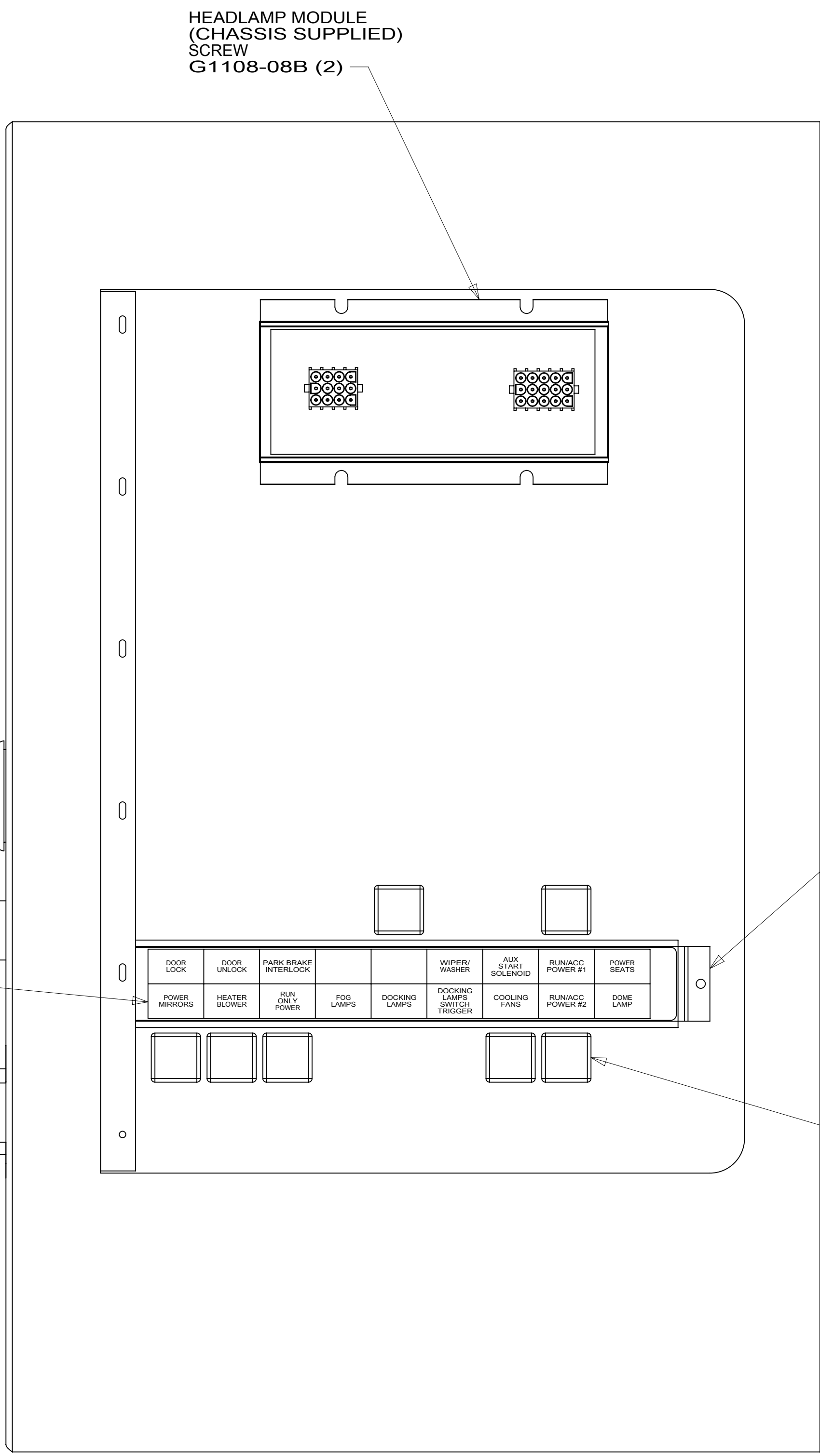

- NOTES:
- 3 SEAL ALL SCREWS ON EXTERIOR SIDE OF COMPARTMENT. REFER TO SEALANT MANUAL.
 - 2 CIRCUIT FFD IS PART OF WIRE ASM-CHASSIS.
 - 1 CIRCUITS LABELED ON BREAKER ARE FROM WIRE ASM-IP, MAIN, UNLESS OTHERWISE SPECIFIED.

FOR ELECTRICAL TORQUE SPECIFICATIONS SEE DWG NO. 128783-01-000

X-X

FOR ELECTRICAL CALLOUTS SEE DWG NO. 121339-01-000

265 CODES/STANDARDS-CSA/CMVSS

1B1 CODES/STANDARDS USA

1B1 265

FIRST USED

14 L-SERIES

DO NOT SCALE DRAWING

TITLE: WIRING INSTL-FRONT END

SHEET 3 PART NO 185576 REV

1 30-Dec-2014

185576

8 7 6 5 4 3 2 1

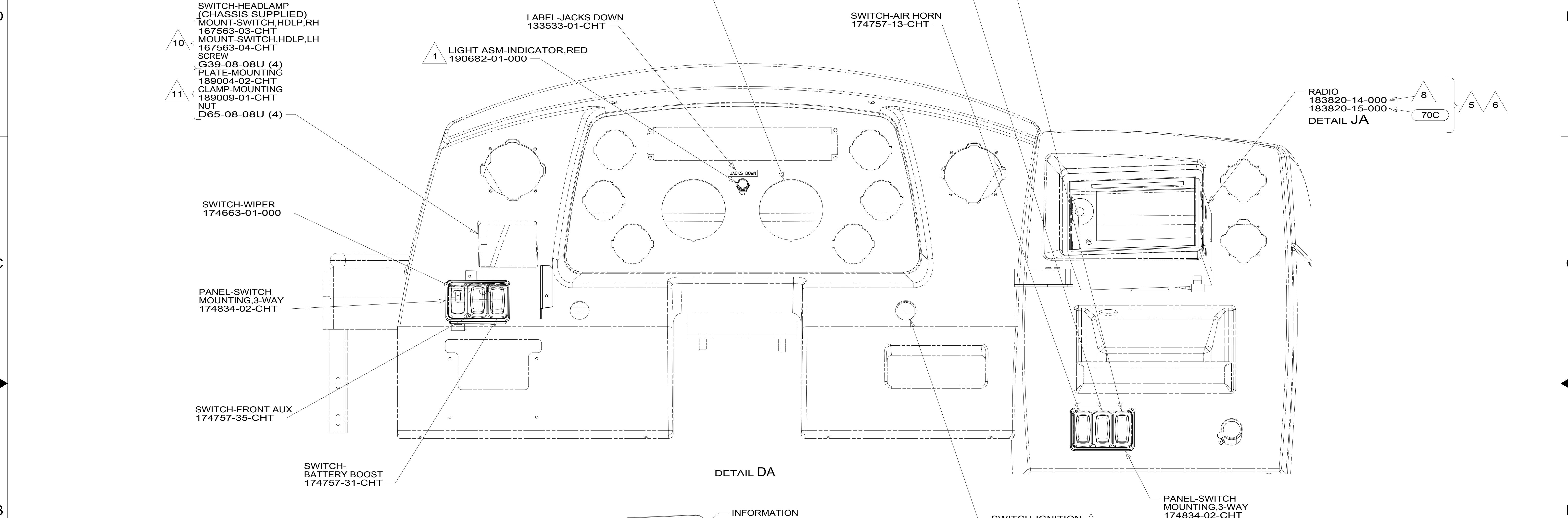

- 11 CHASSIS SUPPLIED ROCKER SWITCHES. DOME LAMP SWITCH NOT USED. SEE DETAIL DC FOR SWITCH POSITION.
- 10 CHASSIS SUPPLIED COMPOSITE SWITCH.
- 9 REPLACE CHASSIS SUPPLIED IGNITION SWITCH.
- 8 WITHOUT 70C
7. APPLY TAPE 8363-01-000 AS NECESSARY TO SECURE NON-LOCKING CONNECTIONS.
- 6 ATTACH TO RADIO WITH SCREW SUPPLIED WITH RADIO.
- 5 PLUG USB CABLE INTO LEAD ON BACK OF RADIO MARKED 'USB' ROUTE CABLE TO DASH POCKET BELOW RADIO.
- 4 SEE SHEET 5 FOR GAUGE PLACEMENT.
- 3 MOUNT SWITCH SO WHEN ACTUATOR IS PUSHED LEFT, THE LETTER L IS SHOWING.
- 2 CONNECT TO MATING LABELED CONNECTOR ON CHASSIS SUPPLIED WIRING.
- 1 CONNECT POSITIVE WIRE TO TERMINAL MARKED WITH A "+", YEL-WINNEBAGO WIRING RED-HWH WIRING

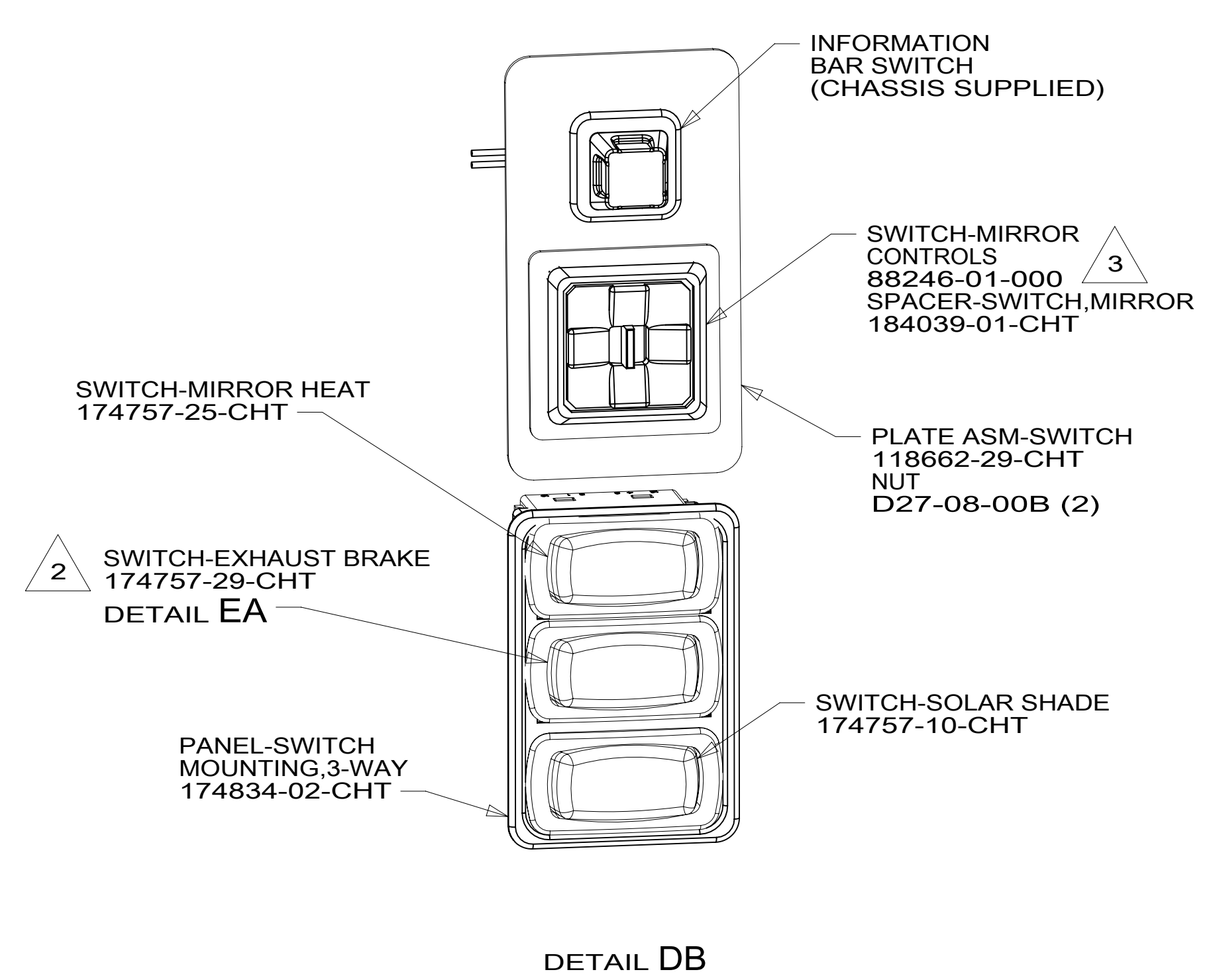

- 70C RADIO - SATELLITE
- 1LE FRTL 44,320 400HP 6SPD TAG
- 1AH FRTL 34,320 380HP 8.3L 6 SPD
- 1AC FRTL 32,350 360HP 6.7L 6 SPD
- 1AB FRTL 27,910 340 6.7L 10 EMM
- 15D GPS-NAVIGATION SYSTEM
- 15C GPS-NAVIGATION SYSTEM W/O
- 265 CODES/STANDARDS-CSA/CMVSS
- 1B1 CODES/STANDARDS USA

FIRST USED	
14 L-SERIES	
DO NOT SCALE DRAWING	
TITLE: WIRING INSTL-FRONT END	
SHEET 4	PART NO 185576 REV
1 30-Dec-2014	

FOR ELECTRICAL TORQUE SPECIFICATIONS SEE DWG NO. 128783-01-000

FOR ELECTRICAL CALLOUTS SEE DWG NO. 121339-01-000

WIRE ASM-EXHAUST BRAKE SWITCH
157534-07-000

1
CONNECTS TO
CHASSIS WIRING

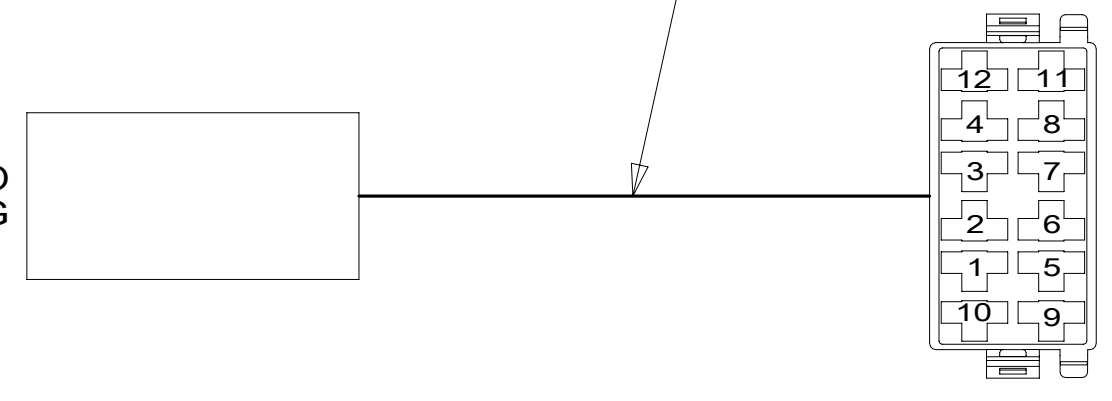

DETAIL EA

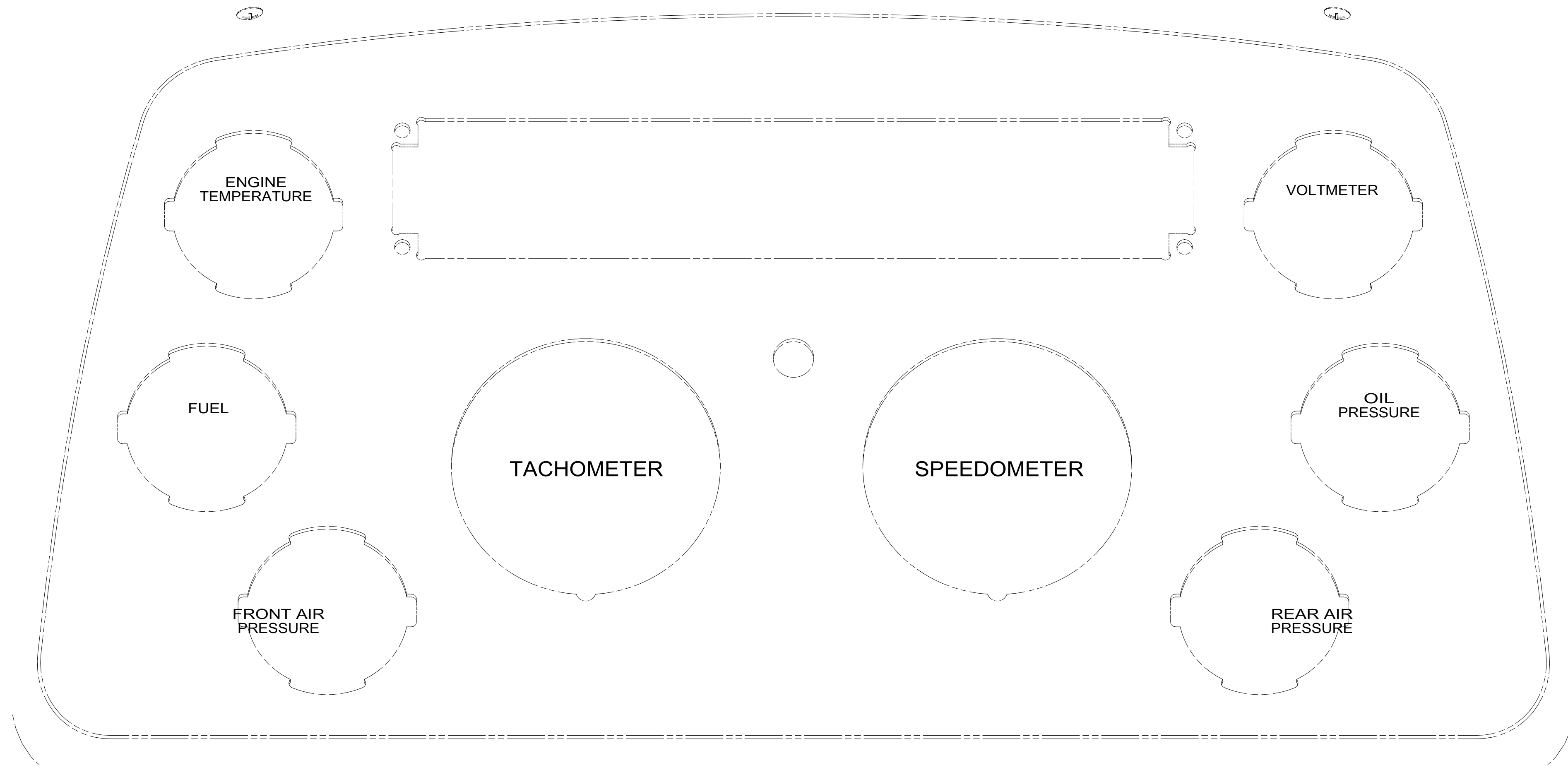

FREIGHTLINER CLUSTER
LOCATION

1 CHASSIS WIRING HAS MATING CONNECTOR
AND IS LABELED "ENGINE BRAKE SWITCH"

FOR ELECTRICAL
TORQUE
SPECIFICATIONS
SEE DWG NO.
128783-01-000

X-X
FOR
ELECTRICAL
CALLOUTS
SEE DWG NO.
121339-01-000

265 CODES/STANDARDS-CSA/CMVSS

1B1 CODES/STANDARDS USA

1B1 265

FIRST USED
14 L-SERIES

DO NOT SCALE DRAWING

TITLE:
WIRING INSTL-FRONT END

SHEET 5 PART NO **185576** REV

8

7

6

5

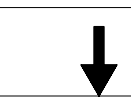

4

3

2

1

D

D

C

C

B

B

A

A

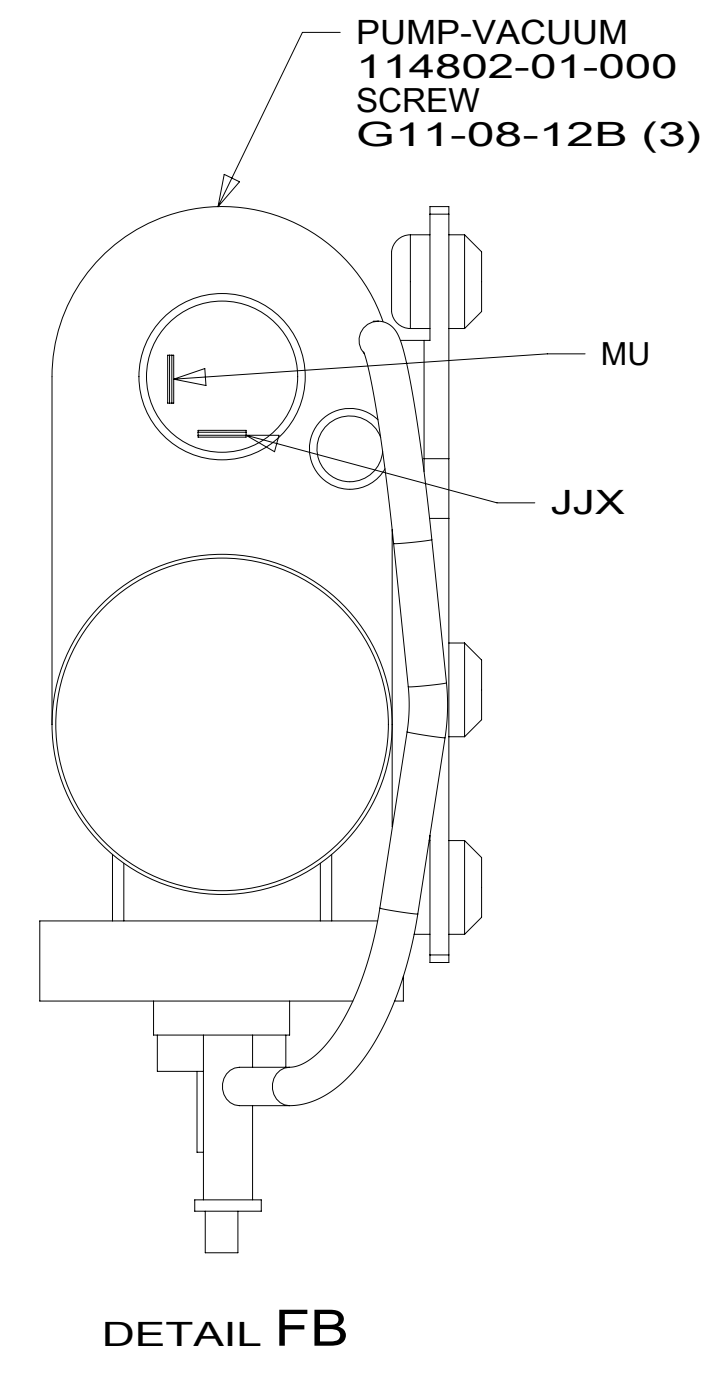
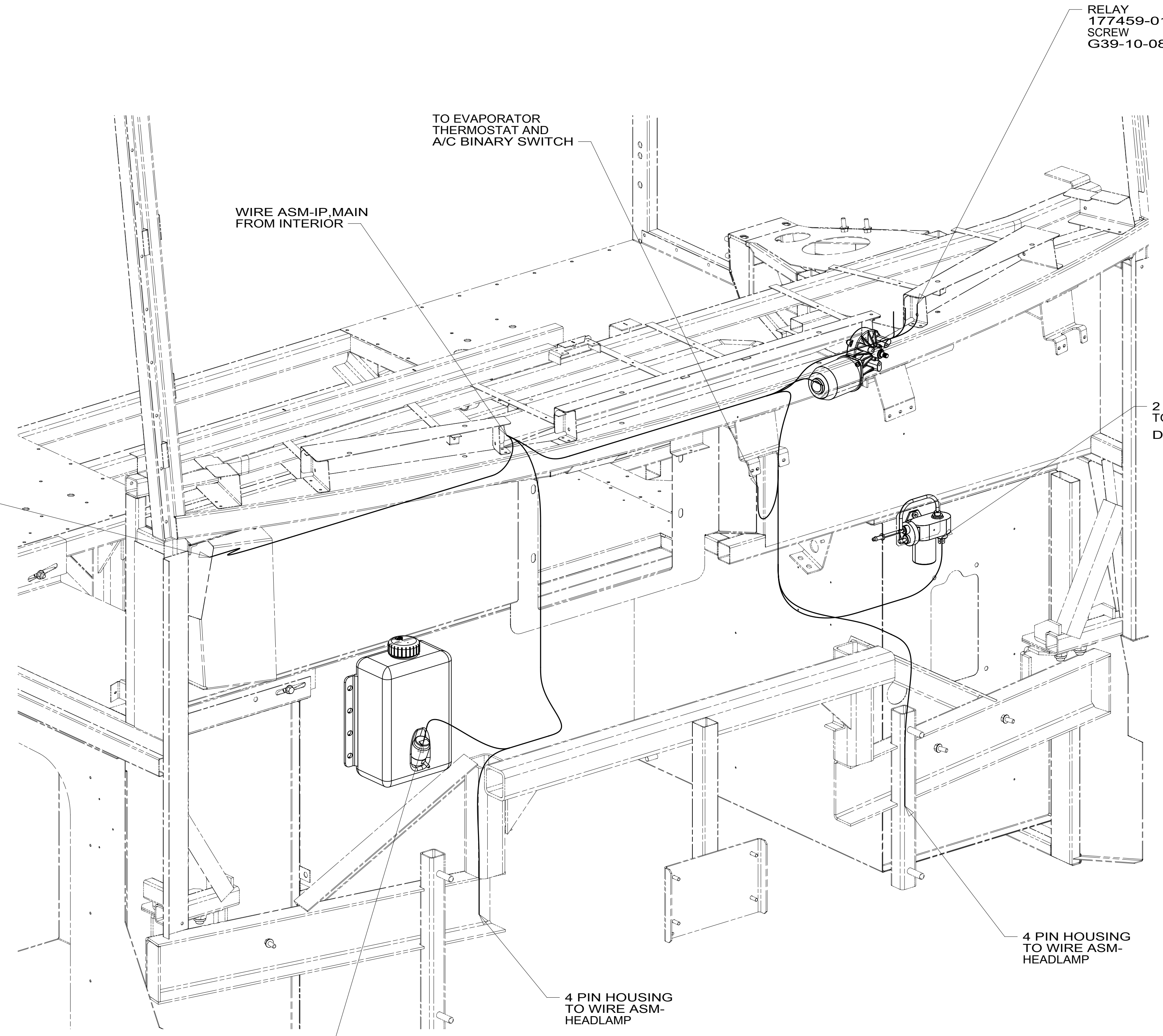

VIEW FA

265 CODES/STANDARDS-CSA/CMVSS

1B1 CODES/STANDARDS USA

1B1 265

FIRST USED **14 L-SERIES**

DO NOT SCALE DRAWING

TITLE: **WIRING INSTL-FRONT END**

SHEET 6 PART NO **185576** REV

FOR ELECTRICAL TORQUE SPECIFICATIONS SEE DWG NO. 128783-01-000

X-X FOR ELECTRICAL CALLOUTS SEE DWG NO. 121339-01-000

185576

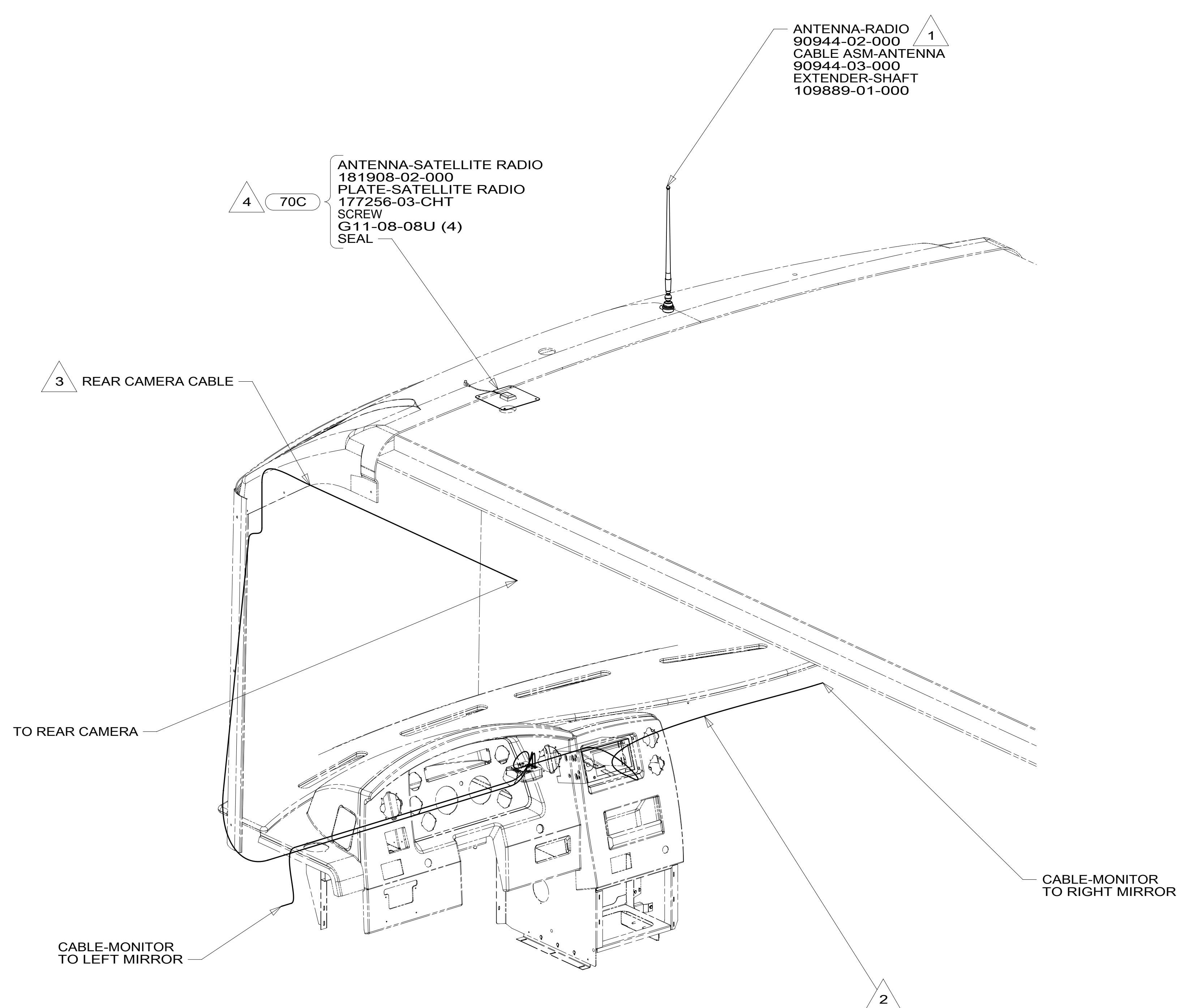
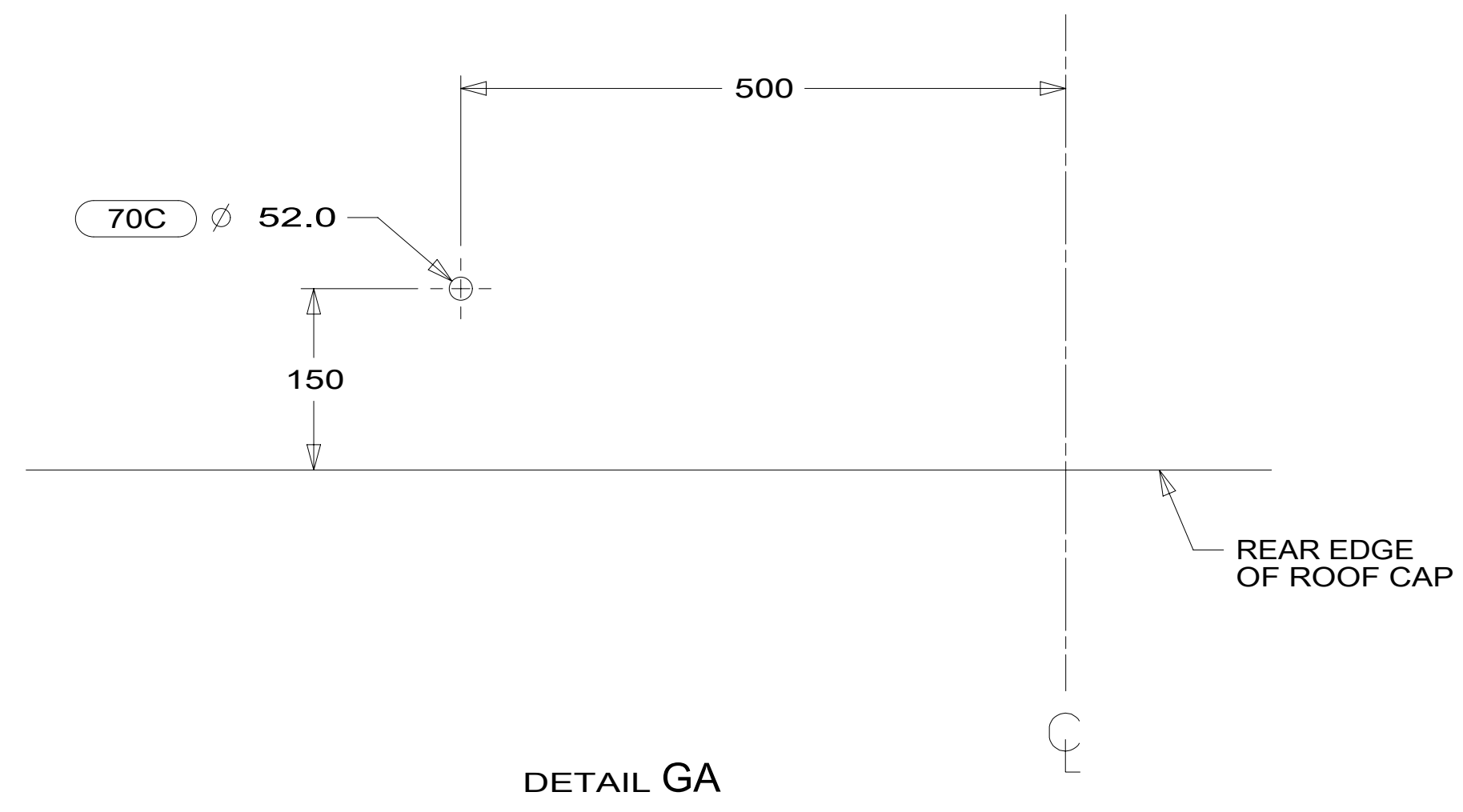

- NOTES:
- 4 MOUNT ANTENNA SUCH THAT BASE IS SQUARE WITH REAR OF ROOF CAP AND COVERS HOLE IN ROOF.
 - 3 RUN CABLE UP A-PILLAR THRU LEFT HAND COVE TO REAR OF UNIT.
 - 2 ROUTE CABLE TO EXTERIOR THRU HOLE IN PANEL ALONG WITH HEATER WIRING TO RIGHT CAMERA IN MIRROR.
 - 1 SEAL AROUND ANTENNA BASE.

- 70C RADIO - SATELLITE
- 265 CODES/STANDARDS-CSA/CMVSS
- 1B1 CODES/STANDARDS USA

FIRST USED	
14 L-SERIES	
DO NOT SCALE DRAWING	
TITLE: WIRING INSTL-FRONT END	
SHEET 7	PART NO 185576 REV

FOR ELECTRICAL TORQUE SPECIFICATIONS SEE DWG NO. 128783-01-000

FOR ELECTRICAL CALLOUTS SEE DWG NO. 121339-01-000

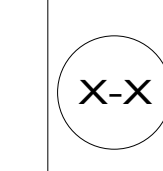

185576

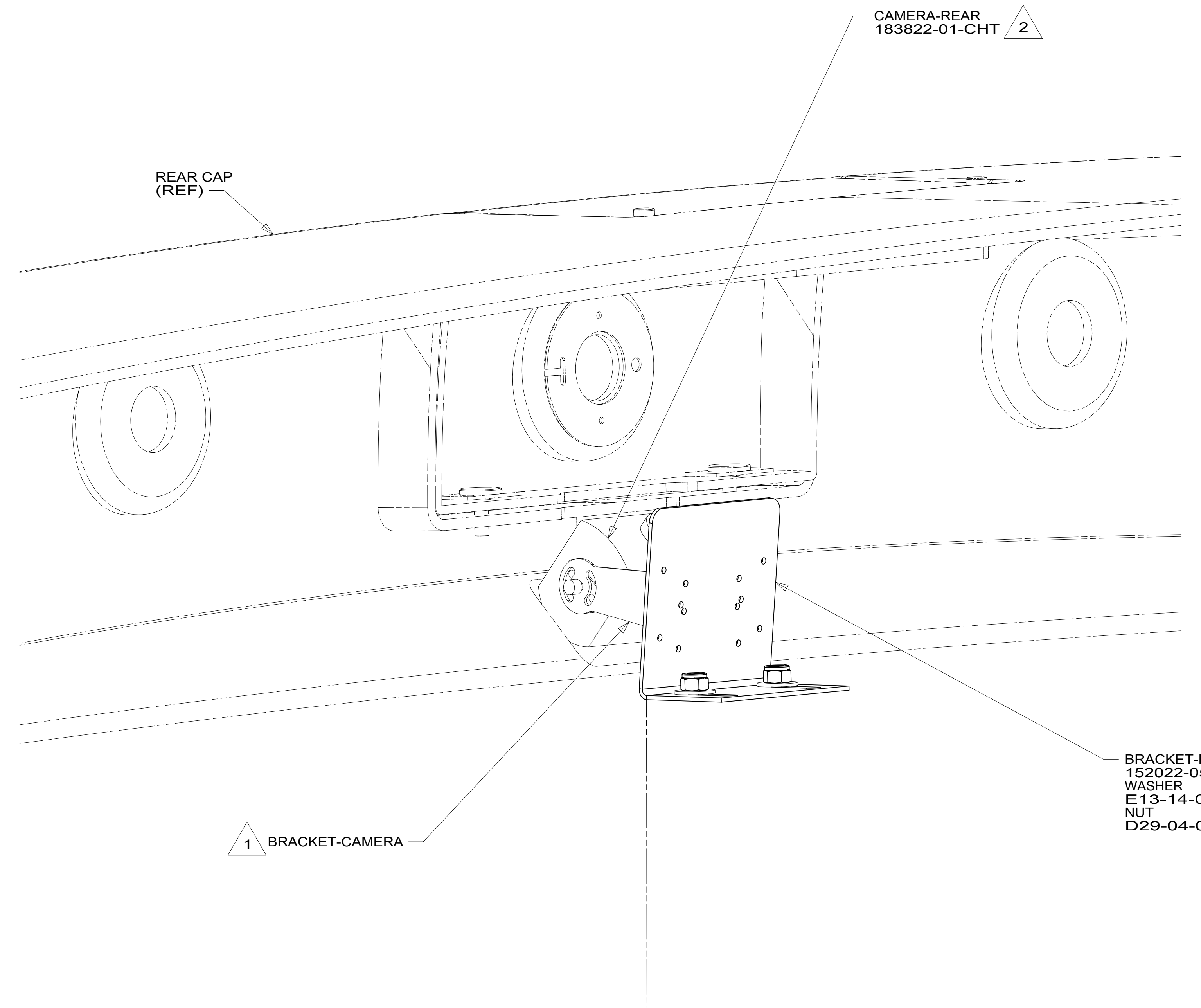

- 2 ALIGN CAMERA IN CENTER OF SHROUD OPENING AND ADJUST SO BACKWALL IS JUST VISIBLE.
- 1 PARTS SUPPLIED WITH REAR CAMERA, VISOR NOT USED.

NOTES:

FOR ELECTRICAL TORQUE SPECIFICATIONS SEE DWG NO. 128783-01-000

FOR ELECTRICAL CALLOUTS SEE DWG NO. 121339-01-000

- 265 CODES/STANDARDS-CSA/CMVSS
- 1B1 CODES/STANDARDS USA
- 1B1 265

FIRST USED	
14 L-SERIES	
DO NOT SCALE DRAWING	
TITLE: WIRING INSTL-FRONT END	
SHEET 8	PART NO 185576 REV
1 30-Dec-2014	

*185576 *A

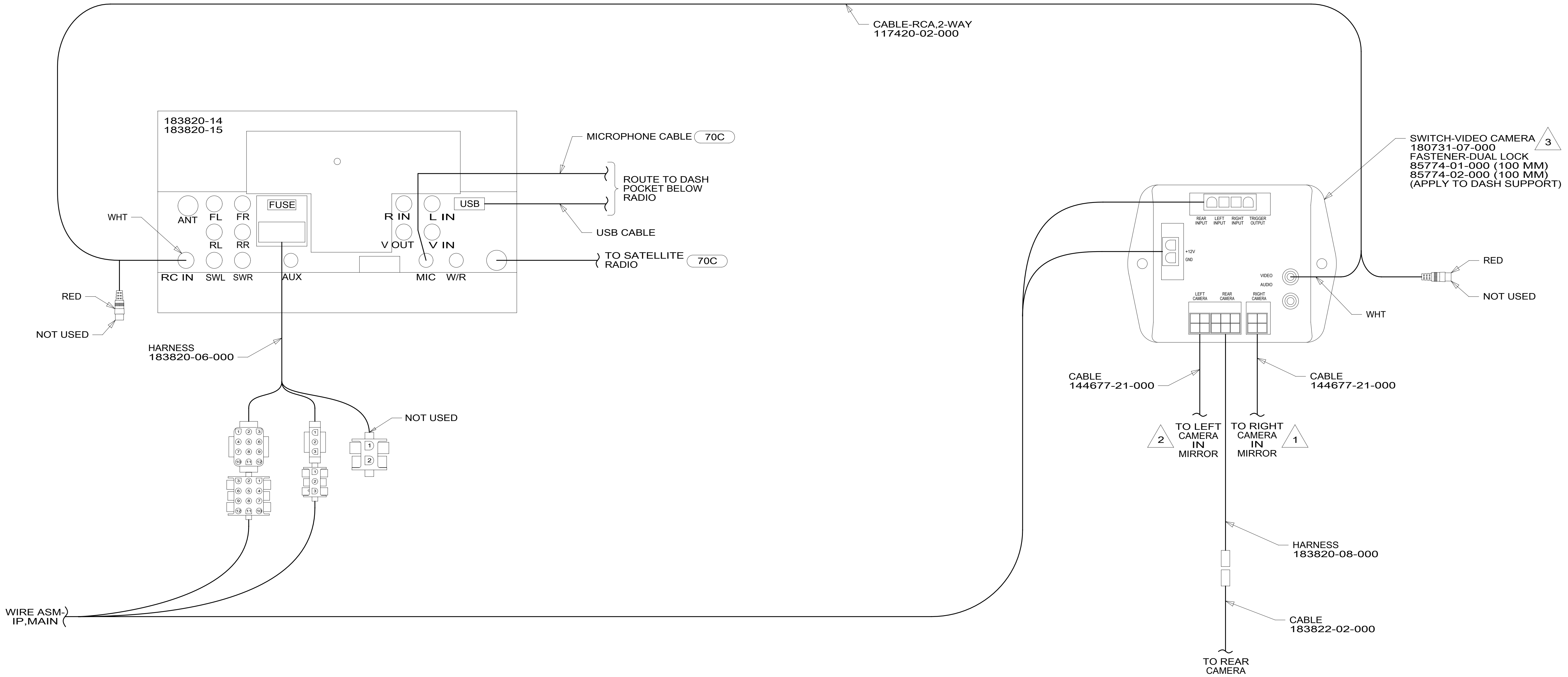

DETAIL JA

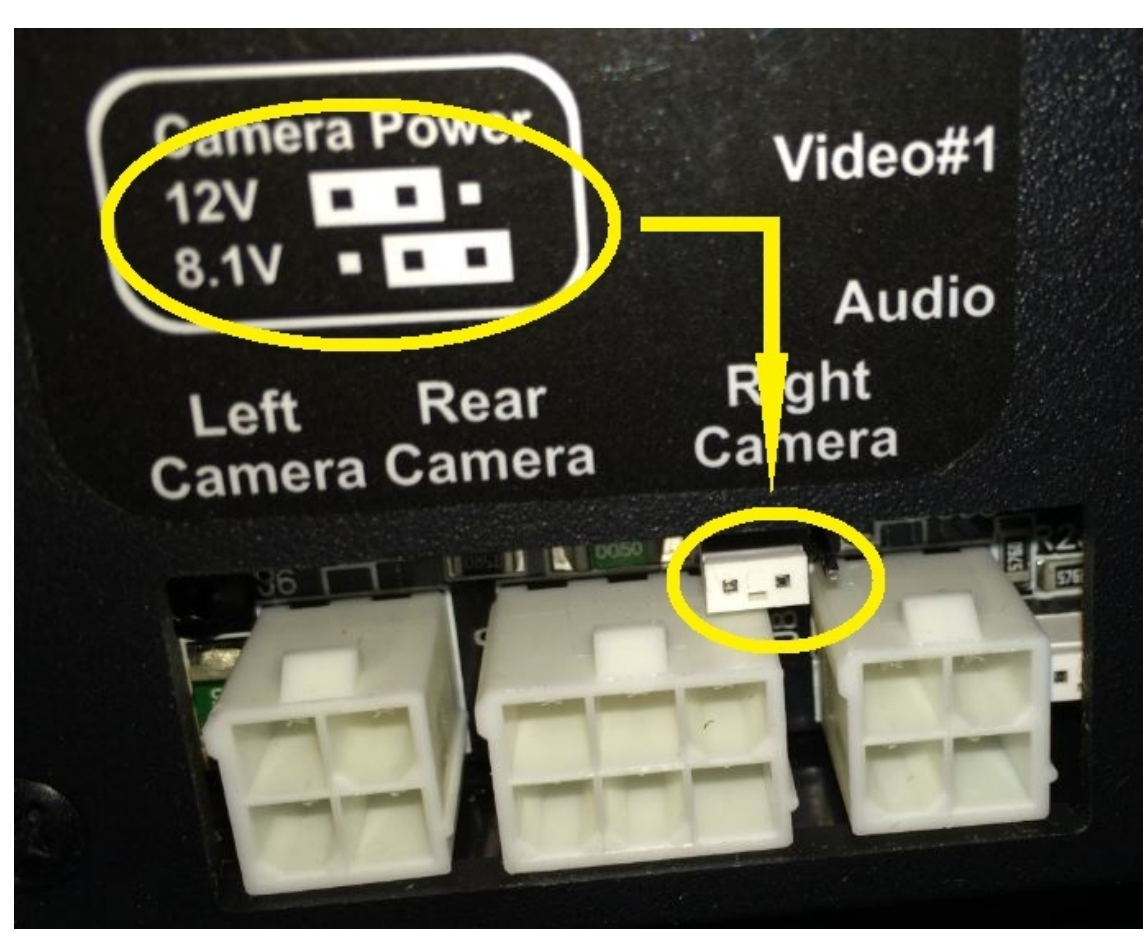

DETAIL JB

- NOTES:
- 3 ENSURE CAMERA POWER JUMPER IS IN 12 VOLT POSITION. MOVE TO 12V POSITION IF NECESSARY. SEE DETAIL JB
 - 2 MARK LEFT CABLE WITH YELLOW TAPE 900000-07-000 NEXT TO CONNECTOR.
 - 1 MARK RIGHT CABLE WITH WHITE TAPE 900000-08-000 NEXT TO CONNECTOR.

- 70C RADIO - SATELLITE
- 265 CODES/STANDARDS-CSA/CMVSS
- 1B1 CODES/STANDARDS USA

FIRST USED	14 L-SERIES	
DO NOT SCALE DRAWING		
TITLE: WIRING INSTL-FRONT END		
SHEET 9	PART NO 185576	REV

FOR ELECTRICAL TORQUE SPECIFICATIONS SEE DWG NO. 128783-01-000

FOR ELECTRICAL CALLOUTS SEE DWG NO. 121339-01-000

185576