

DWG NO	TOILET-MACERATOR	MODEL
188145-01	170062-01-CHT	R42HD
188145-02	170062-06-CHT	R42HL

RELEASE	REV/DATE	DWG NO	188145
REV ZONE	REVISION RECORD	DATE	DTR-ORIG

D

D

C

C

B

B

A

A

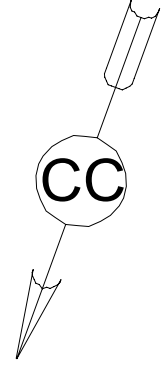
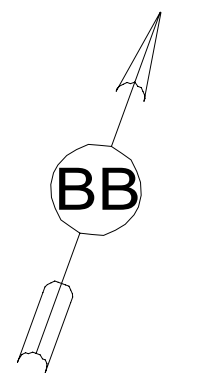
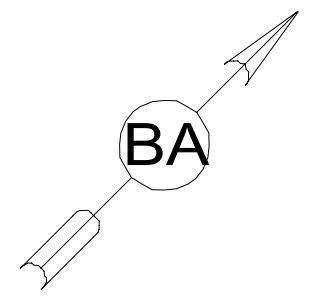
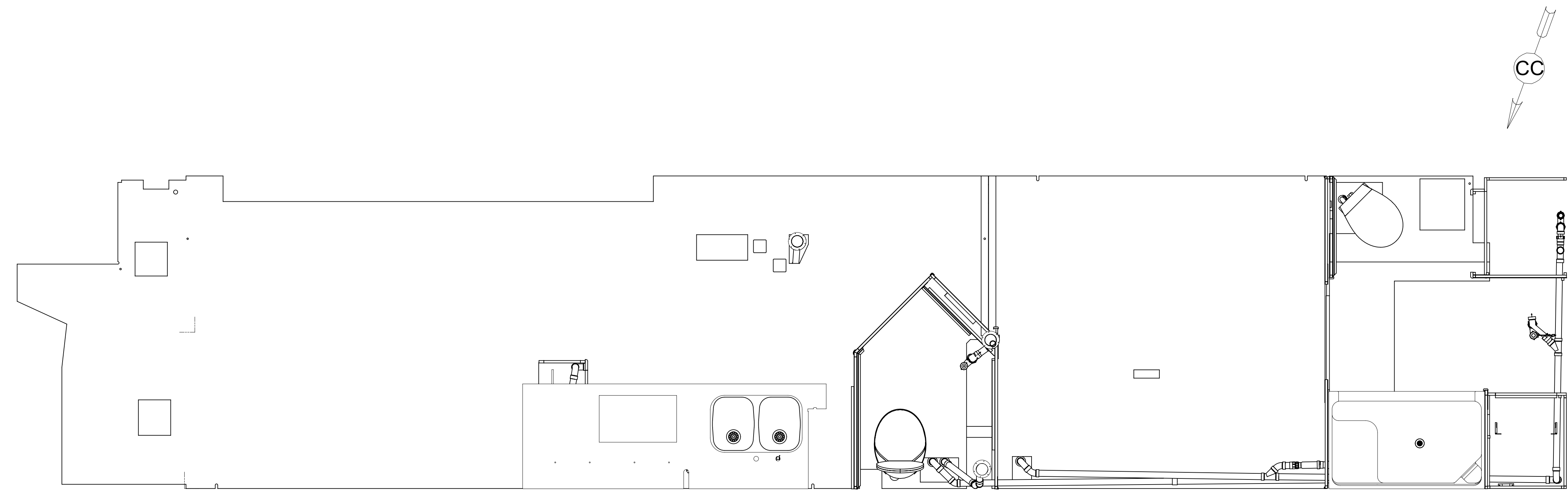

- 9PC TAILGATE PACKAGE
- 9PA TAILGATE PACKAGE WITHOUT
- 21S WASHER/DRYER STACKED
- 1B1 CODES/STANDARDS USA
- 265 CODES/STDS-CSA,CMVSS
- 54E WASHER DRYER
- 21M WASHER/DRYER PREP
- 214 DISHWASHER DRAWER STYLE

- 10. APPLY PRIMER 126427-02-000 AND CEMENT 126427-01-000 BETWEEN ELBOW AND FLEX PIPE.
- 9. SEE DRAWING 061607 FOR INSTALLATION OF GROMMETS.
- 8. SECURE DRAINAGE PIPES TO CABINET USING WIRE TIE 108046-02-000, AND SCREW 000G67-10-12U AT INTERVALS OF NOT OF NOT MORE THAN 4 FEET APART.
- 7. SECURE VENT PIPE TO GROMMET WITH CLAMP 062401-02-000.
- 6. VENT PIPE MUST PROJECT 51 MIN AND 64 MAX ABOVE ROOF FOR PROPER FIT AND FUNCTION. ADD S-1 (116666-01-CHT SEAL-VENT PIPE) AROUND PIPE ON ROOF BEFORE VENT CAP IS INSTALLED.
- 5. SEAL AROUND SHOWER WITH SILICONE.
- 4. USE SMOOTH PLUMBERS PUTTY 167459-01-000 TO SEAL STRAINER (0.2 PER STRAINER).
- 3. ALL PIPE AND FITTINGS TO BE ASSEMBLED WITH SOLVENT 004020-01-000 (USA), 004020-02-000 (CAN)
- 2. SLOPE OF TRAP ARM MUST BE 6 PER 305 mm.
- 1. SLOPE OF HORIZONTAL PIPING TO BE MINIMUM OF 3 PER 305 mm.

NOTES:

FOR DRAINAGE CALLOUTS SEE DWG NO 116229-01-000

WINNEBAGO		COPYRIGHT 2014 WINNEBAGO INDUSTRIES, INC.	
DTR	ORIG. DATE	ALL DIMENSIONS ARE IN MILLIMETERS	
CHKR			
P.E.			
M.E.	FIRST USED		
DSNR		15 R42HD	
UNSPECIFIED TOLERANCES ARE:		MATERIAL:	
WHOLE DIM (X)	: 3		
ONE-PLACE (X.X)	: 1.5		
TWO-PLACE (X.XX)	: 0.50		
ANGLE	: 1°		
THIRD ANGLE PROJECTION			
DO NOT SCALE DRAWING		REFER TO ES0018 FOR FASTENER TIGHTENING GUIDELINES	
TITLE: DRAINAGE SYSTEM INSTL			
SHEET 1 OF 4	PART NO 188145	REV	
REF:	1	02-Oct-2015	

*188145*A

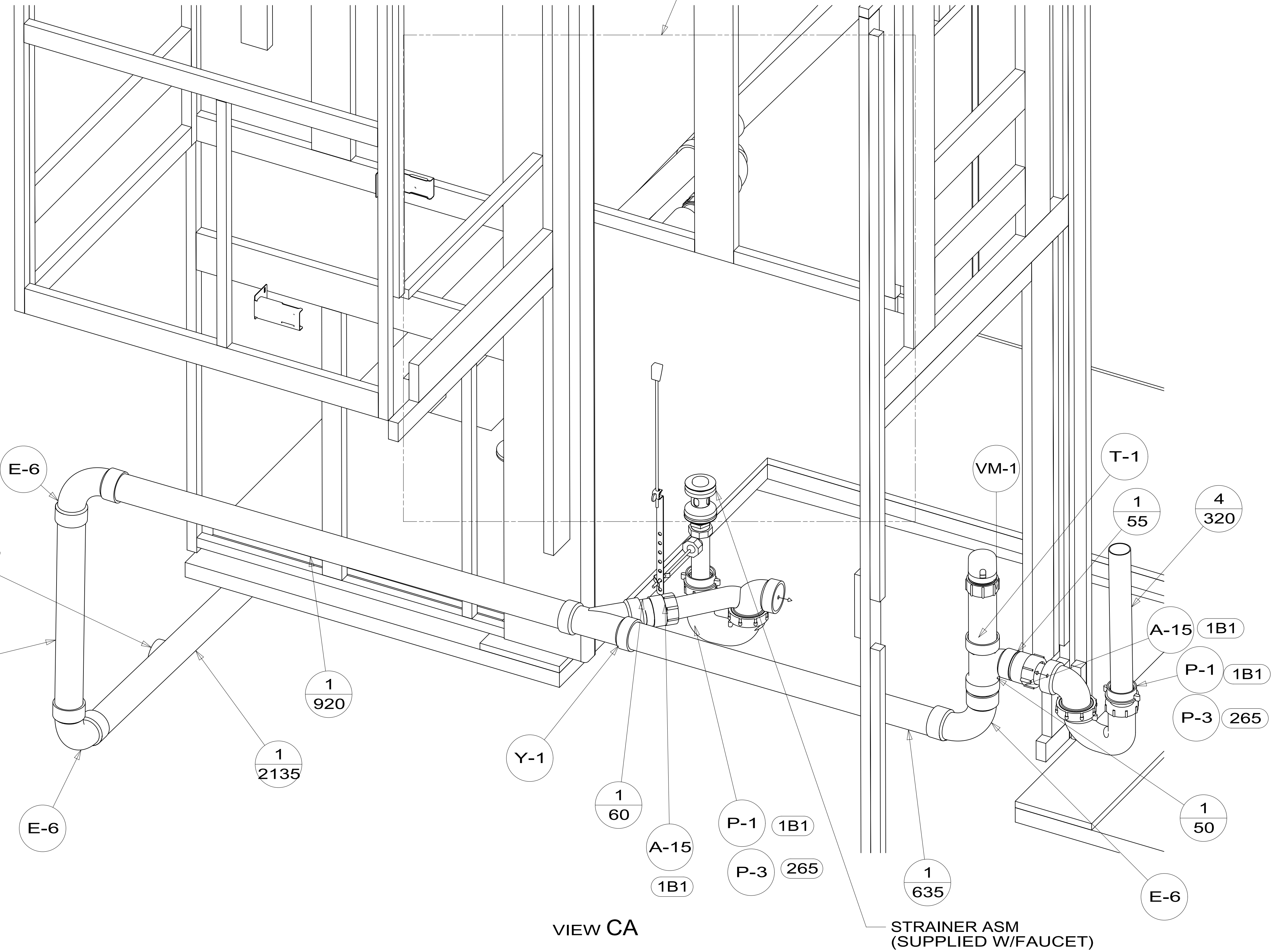
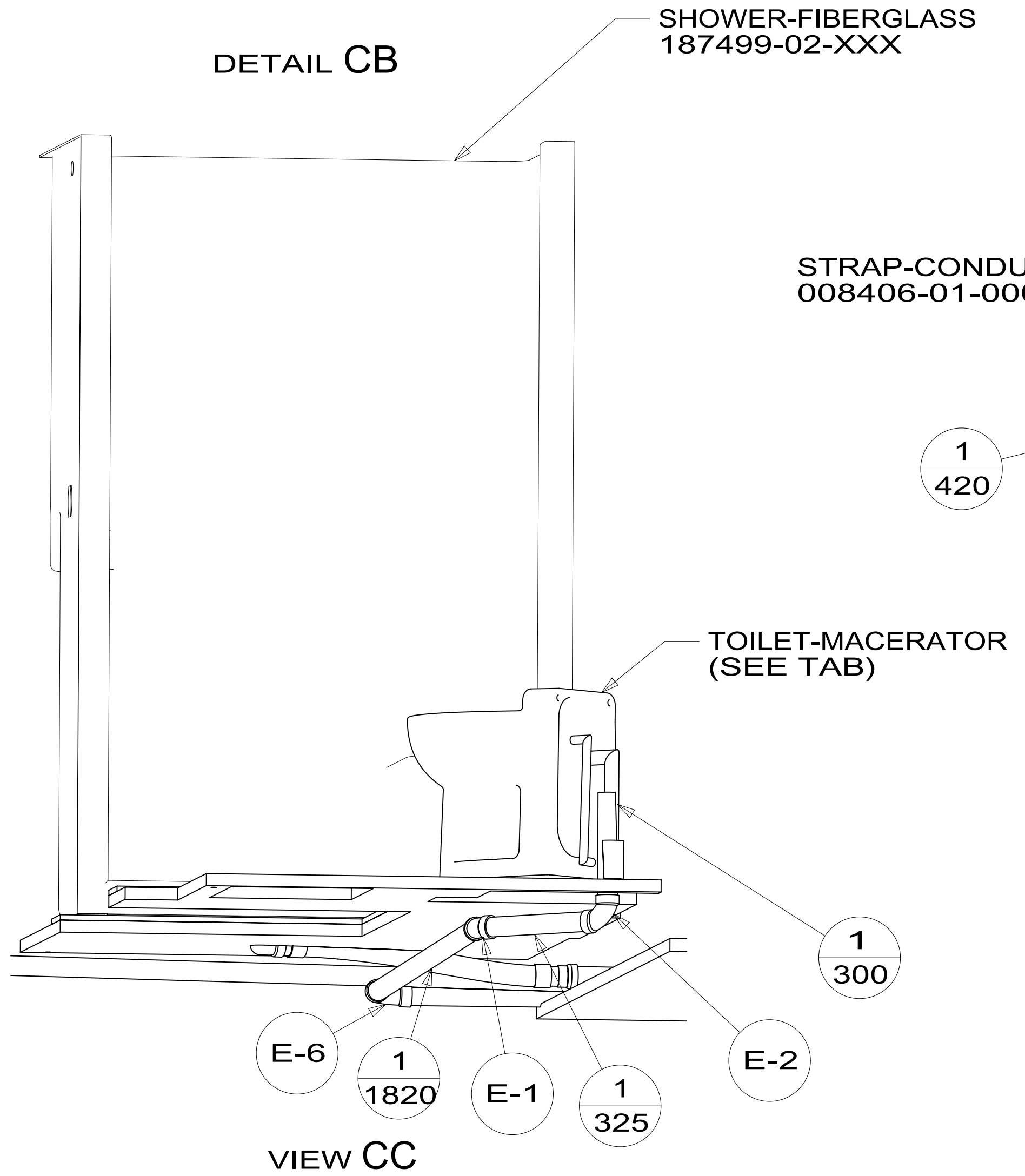
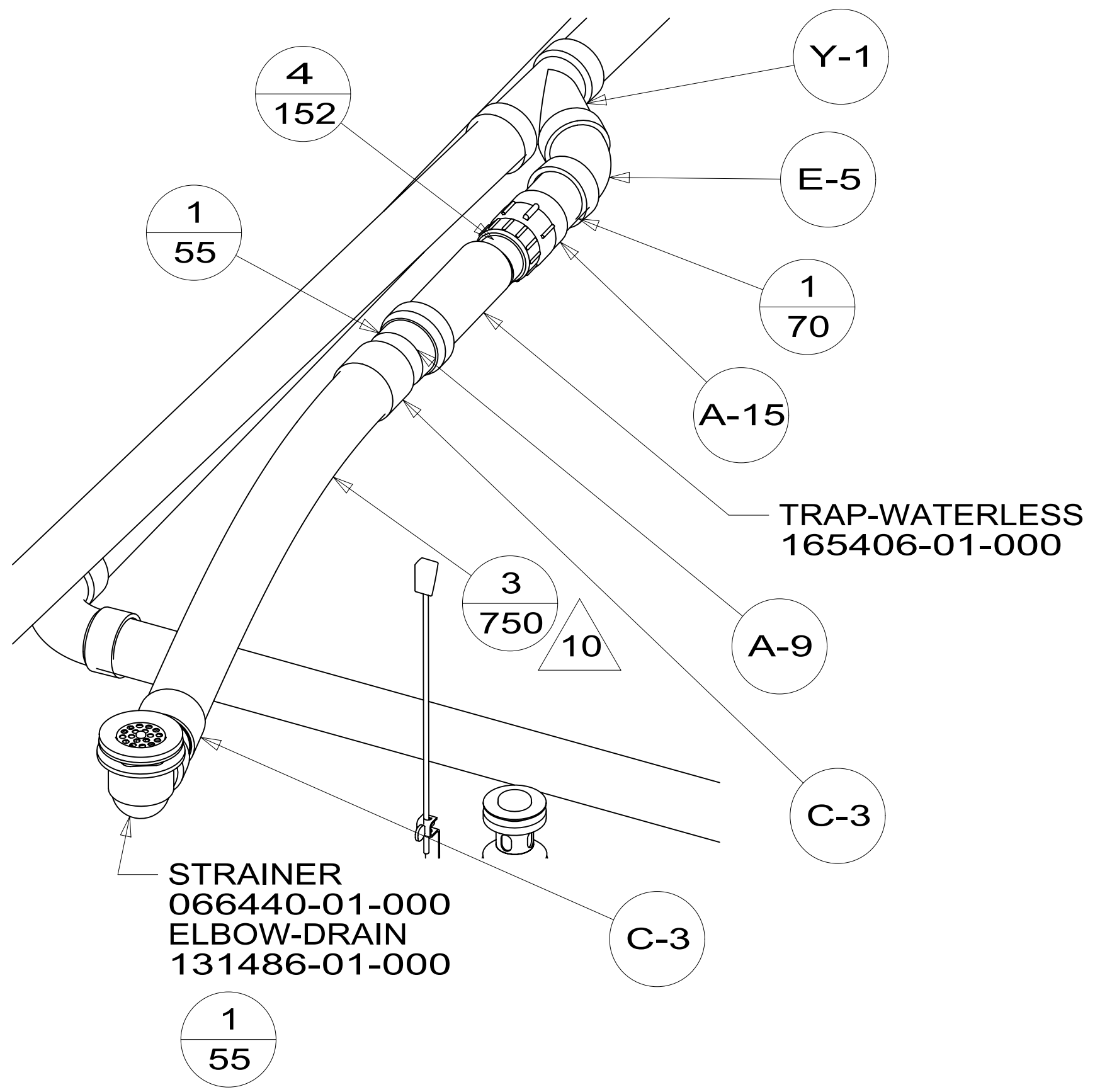

FIRST USED	15 R42HD	
DO NOT SCALE DRAWING		
TITLE: DRAINAGE SYSTEM INSTL		
SHEET 3	PART NO 188145	REV
1 02-Oct-2015		

188145

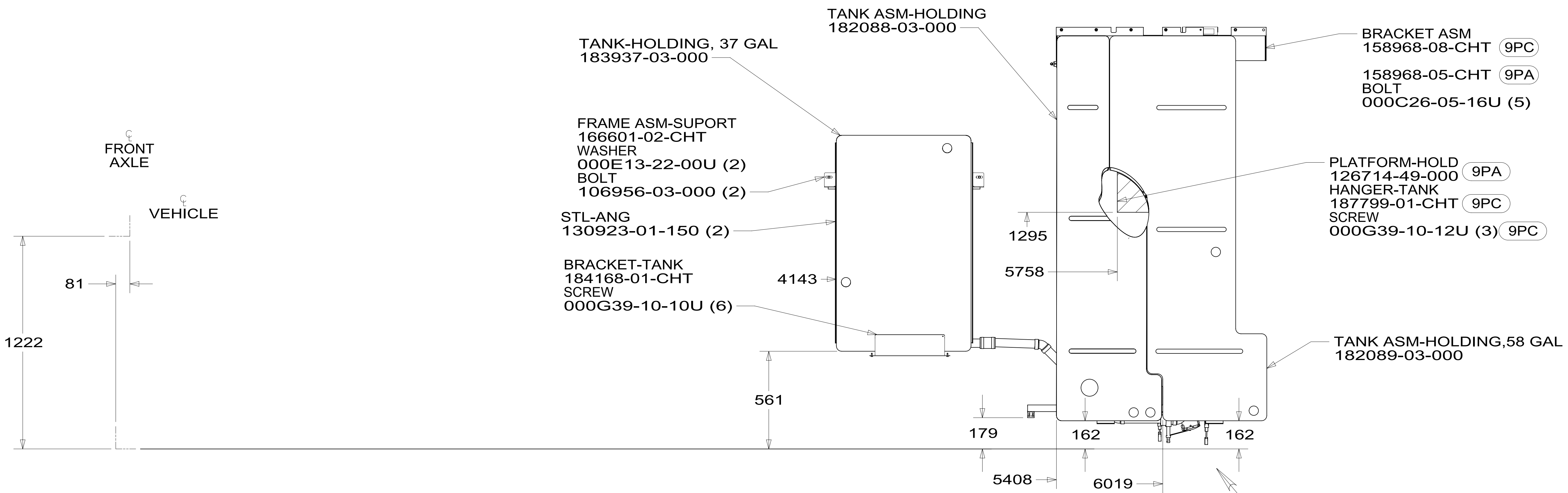

TOP VIEW SHOWING TANKS AND DRAINS

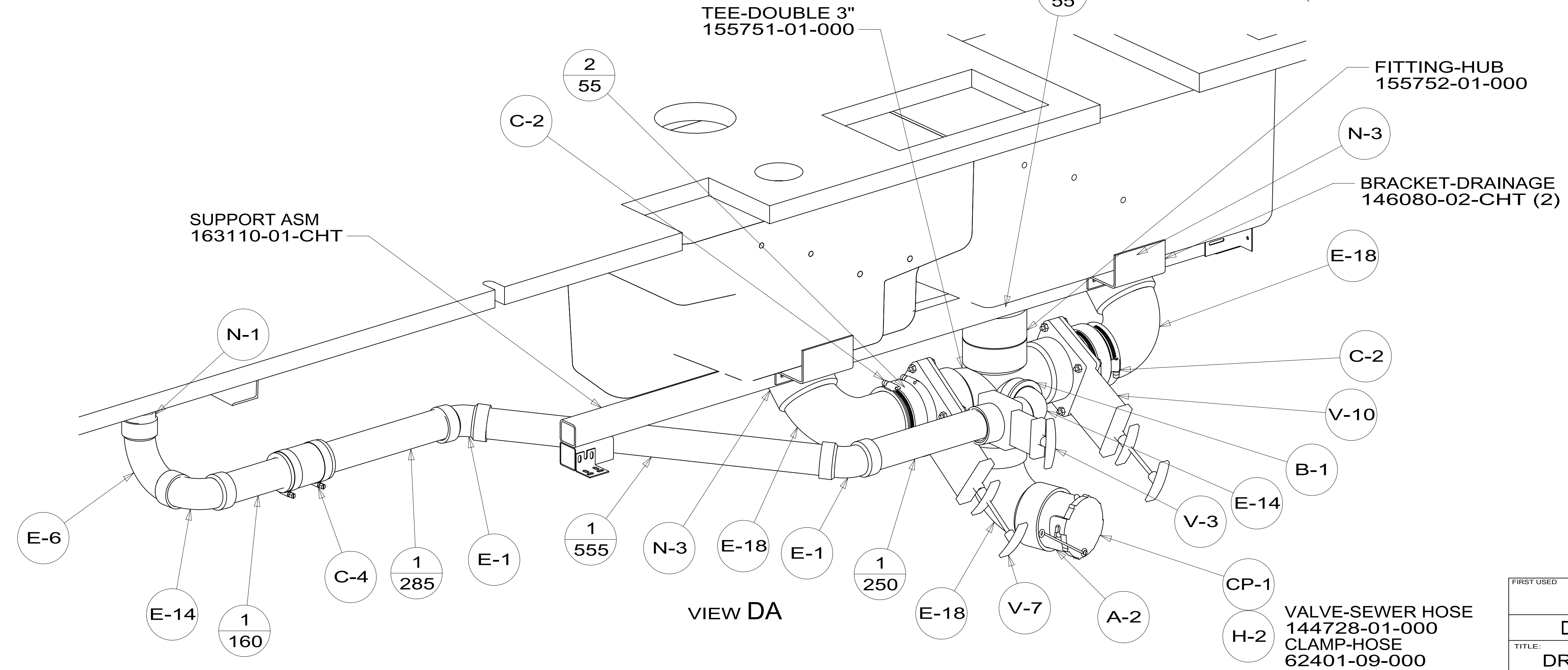

FIRST USED	15 R42HD	
TITLE:	DO NOT SCALE DRAWING	
SHEET	4	PART NO 188145
REV	1	02-Oct-2015

*188145 *A

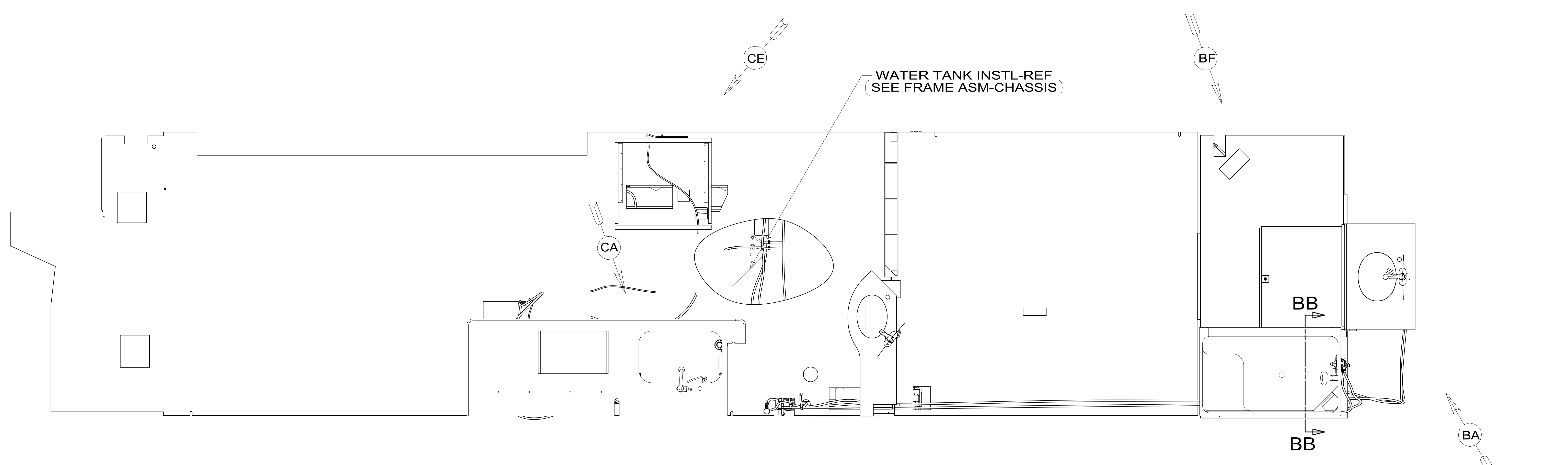

- NOTES:
1. PLASTIC FITTINGS TO BE SEALED WITH SEALANT 084456-01-000.
 2. TUBING TO BE INSTALLED WITH SUFFICIENT SLOPE TO PROVIDE DRAINAGE TO NEAREST VALVE.
 3. ALL TUBING TO BE SECURED AT 1200 INTERVALS MAXIMUM WITH CLAMP 010495-01-000 AND SCREW 000G67-10-12U OR EQUIVALENT.
 4. ADD TEFLON TAPE 010405-02-000.
 5. LABEL HOT AND COLD SUPPLY TUBES AND TAPE FITTING TO TUBE BEFORE CABINET SET TO PREVENT MOVEMENT.
 6. ALL CRIMP FITTINGS TO PEX TUBING REQUIRE 5/8" CLAMP 140171-04-000.
 7. ALL CRIMP FITTINGS TO PEX TUBING REQUIRE 1/2" CLAMP 140171-03-000.
 8. REQUIRES 5 GALLONS OF 182955-01-000 ANTIFREEZE FOR WINTERIZATION.
 9. VALVE MUST REMAIN OPEN AFTER WATER TEST.
 10. INSTALL FAUCET WITHOUT BASE PLATE.
 11. FOR INSTALLATION USE SILICON-ADHESIVE 131264-05-CHT. APPLY ON TOP OF PLATE, PLACE COVER ON, AND PUT ADHESIVE AROUND COVER.

- 9PC TAILGATE PACKAGE
- 21S WASHER & DRYER-PAIR
- 21M WASHER/DRYER PREP
- 214 DISHWASHER-DRAWER STYLE
- 215 DISHWASHER WITHOUT
- 505 HOSE REEL-WATER,POWERED

X-X
 FOR WATER CALLOUTS SEE DWG NO. 116230-01-000

WINNEBAGO		COPYRIGHT 2014 WINNEBAGO INDUSTRIES, INC.	
DFTR	ORIG. DATE	ALL DIMENSIONS ARE IN MILLIMETERS	
CHKR			
P.E.			
M.E.	FIRST USED		
DSNR		15 R42HD	
UNSPECIFIED TOLERANCES ARE:		MATERIAL:	
WHOLE DIM (X)	: 3		
ONE-PLACE (X.X)	: 1.5		
TWO-PLACE (X.XX)	: 0.50		
ANGLE	: 1°		
THIRD ANGLE PROJECTION			
DO NOT SCALE DRAWING		REFER TO ES0018 FOR FASTENER TIGHTENING GUIDELINES	
TITLE: WATER SYSTEM INSTL			
SHEET 1 OF 4	PART NO	188147	REV
REF:	1	05-Oct-2015	

188147

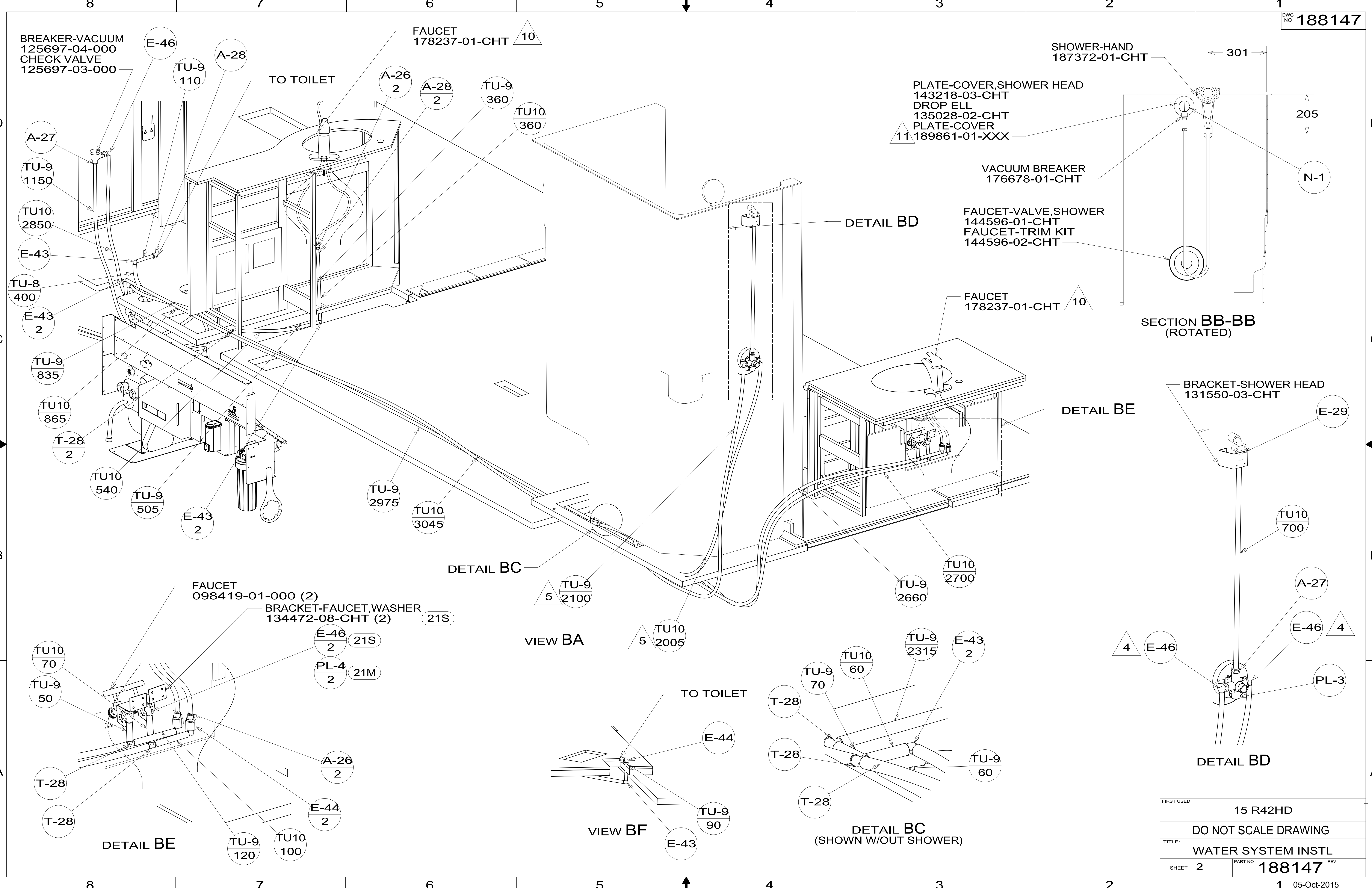

FIRST USED	15 R42HD	
TITLE:	DO NOT SCALE DRAWING	
SHEET	2	PART NO 188147
		REV
1 05-Oct-2015		

188147

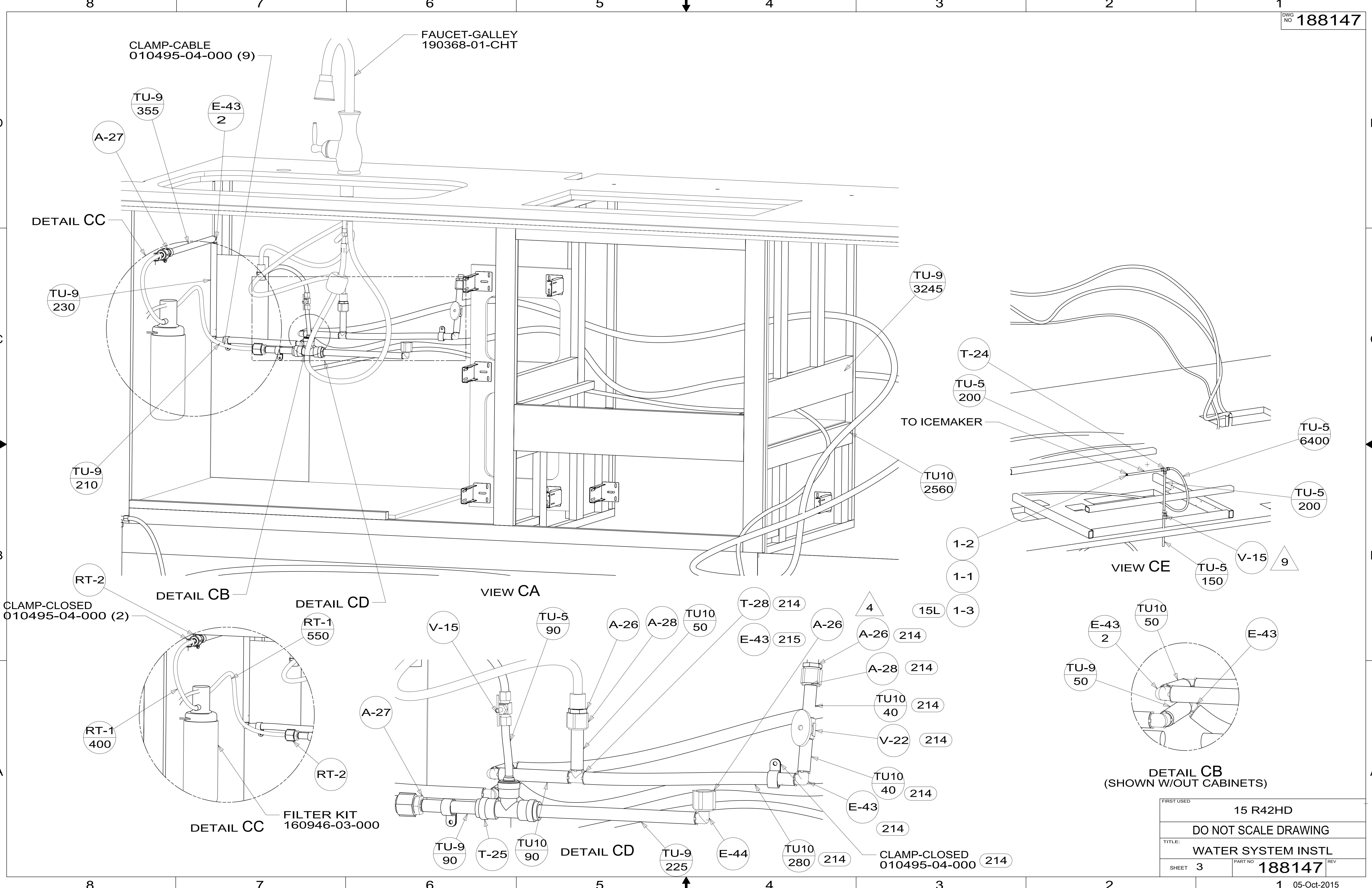

FIRST USED	15 R42HD	
DO NOT SCALE DRAWING		
TITLE:	WATER SYSTEM INSTL	
SHEET 3	PART NO	188147
		REV
		1 05-Oct-2015

188147

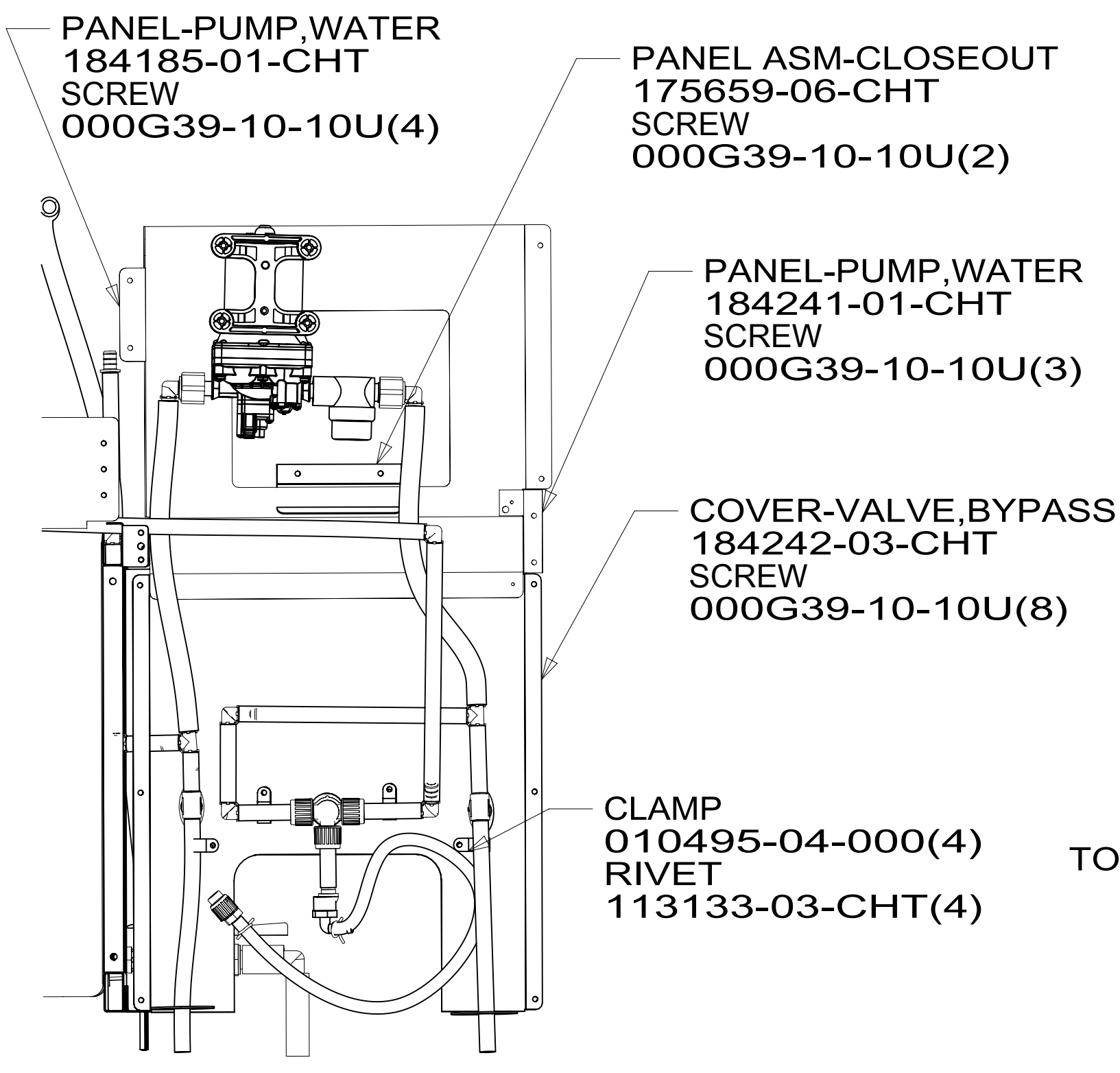

SECTION DC-DC
(ROTATED)

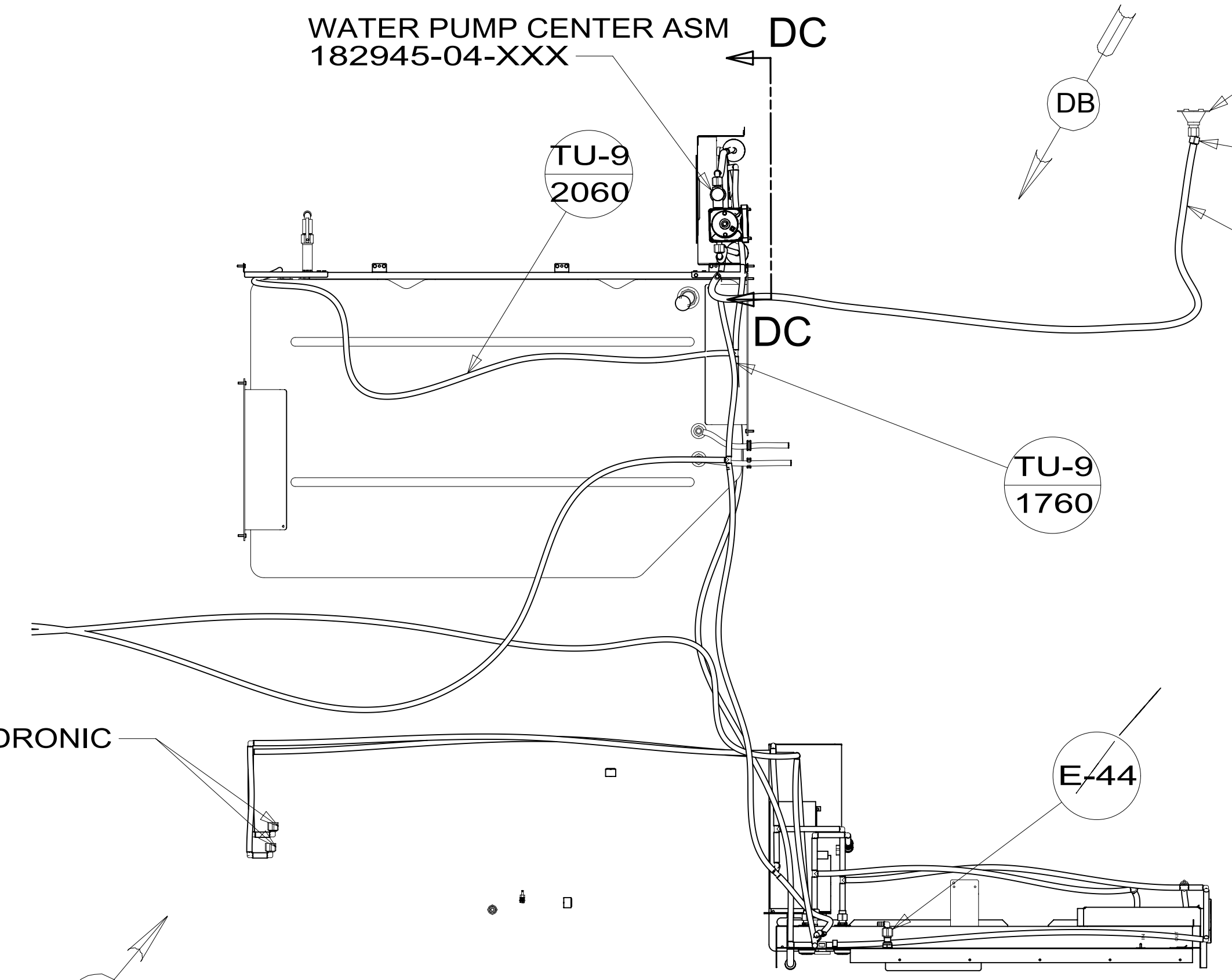

SHOWING LINES UNDER FLOOR

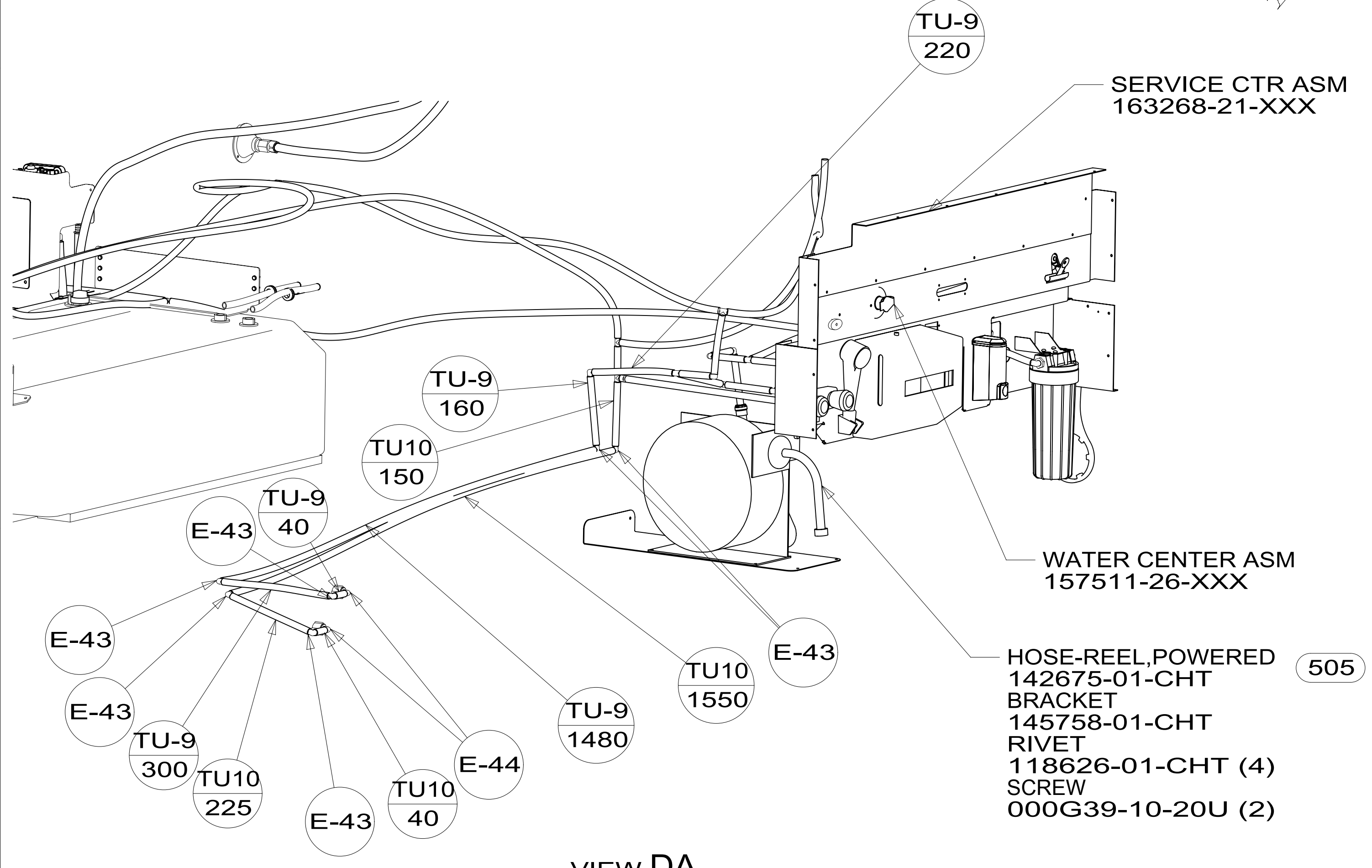

VIEW DA

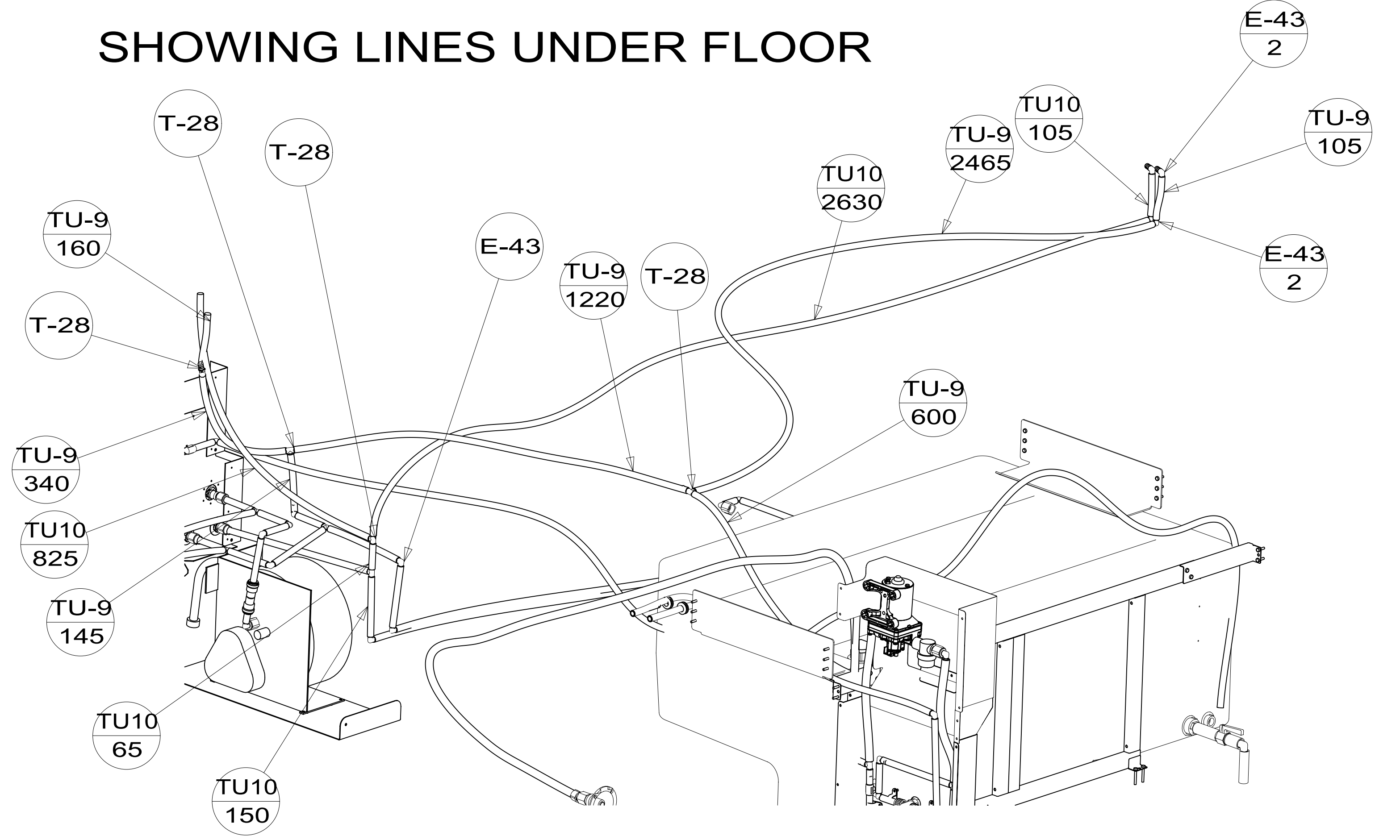

VIEW DB

FIRST USED	15 R42HD	
TITLE:	DO NOT SCALE DRAWING	
SHEET 4	PART NO	188147
	REV	
		05-Oct-2015

188147