

9. SEE DRAWING 061607 FOR INSTALLATION OF GROMMETS.
8. SECURE DRAINAGE PIPES TO CABINET USING WIRE TIE 108046-02-000, AND SCREW 000G67-10-12U AT INTERVALS OF NOT OF NOT MORE THAN 4 FEET APART.
7. SECURE VENT PIPE TO FLOOR WITH CLAMP 062401-02-000 (2), SCREW 000G67-10-12U (2), BRACKET 136878-01-CHT (2).
6. VENT PIPE MUST PROJECT 51 MIN AND 64 MAX ABOVE ROOF FOR PROPER FIT AND FUNCTION. ADD S-1 (116666-01-CHT SEAL-VENT PIPE) AROUND PIPE ON ROOF BEFORE VENT CAP IS INSTALLED.
5. SEAL AROUND SHOWER WITH SILICONE.
4. USE SMOOTH PLUMBERS PUTTY 167459-01-000 TO SEAL STRAINER (0.2 PER STRAINER).
3. ALL PIPE AND FITTINGS TO BE ASSEMBLED WITH SOLVENT 004020-01-000 (USA), 004020-02-000 (CAN)
2. SLOPE OF TRAP ARM MUST BE 6 PER 305 mm.
1. SLOPE OF HORIZONTAL PIPING TO BE MINIMUM OF 3 PER 305 mm.

- 21S WASHER & DRYER-PAIR
- 21M WASHER/DRYER PREP
- 1B1 CODES/STANDARDS-USA
- 265 CODES/STDA-CSA/CMVSS

WINNEBAGO INDUSTRIES, INC. COPYRIGHT 2014

DFT-ORIG	ORIG. DATE
CHKR	ALL DIMENSIONS ARE IN MILLIMETERS
P.E.	
M.E.	FIRST USED
DSNR	14 E36Y
UNSPECIFIED TOLERANCES ARE:	
WHOLE DIM (X)	: 3
ONE-PLACE (X.X)	:
TWO-PLACE (X.XX)	:
ANGLE	:
THIRD ANGLE PROJECTION	
DO NOT SCALE DRAWING	REFER TO ES0018 FOR FASTENER TIGHTENING GUIDELINES
TITLE: DRAINAGE SYSTEM INSTL	
SHEET 1 OF 4	PART NO 186420 REV
REF:	1 08-Jul-2015

FOR DRAINAGE CALLOUTS SEE DWG NO 116229-01-000

NOTES:

*186420 *A

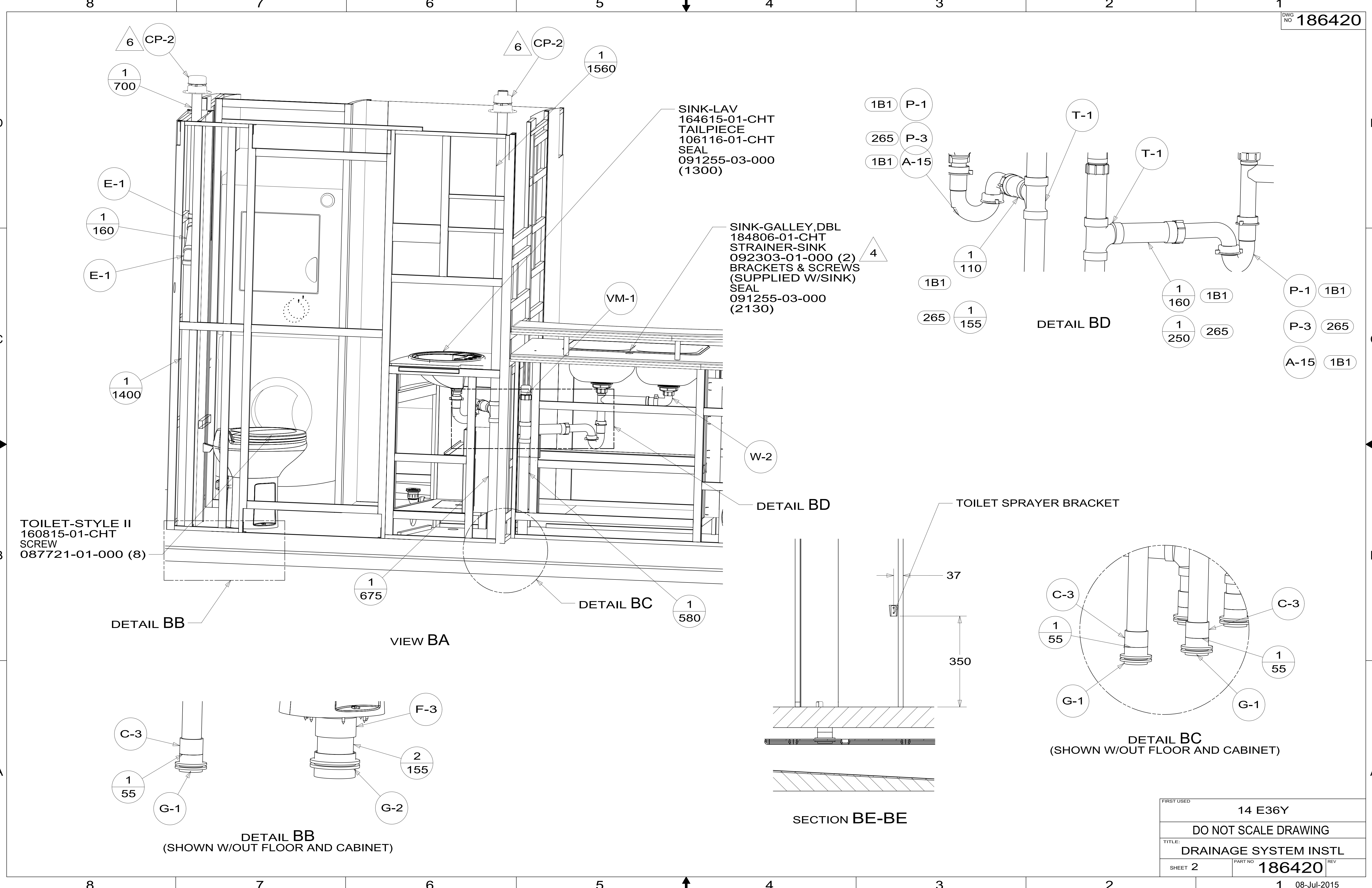

FIRST USED	14 E36Y	
DO NOT SCALE DRAWING		
TITLE: DRAINAGE SYSTEM INSTL		
SHEET 2	PART NO 186420	REV
08-Jul-2015		

186420

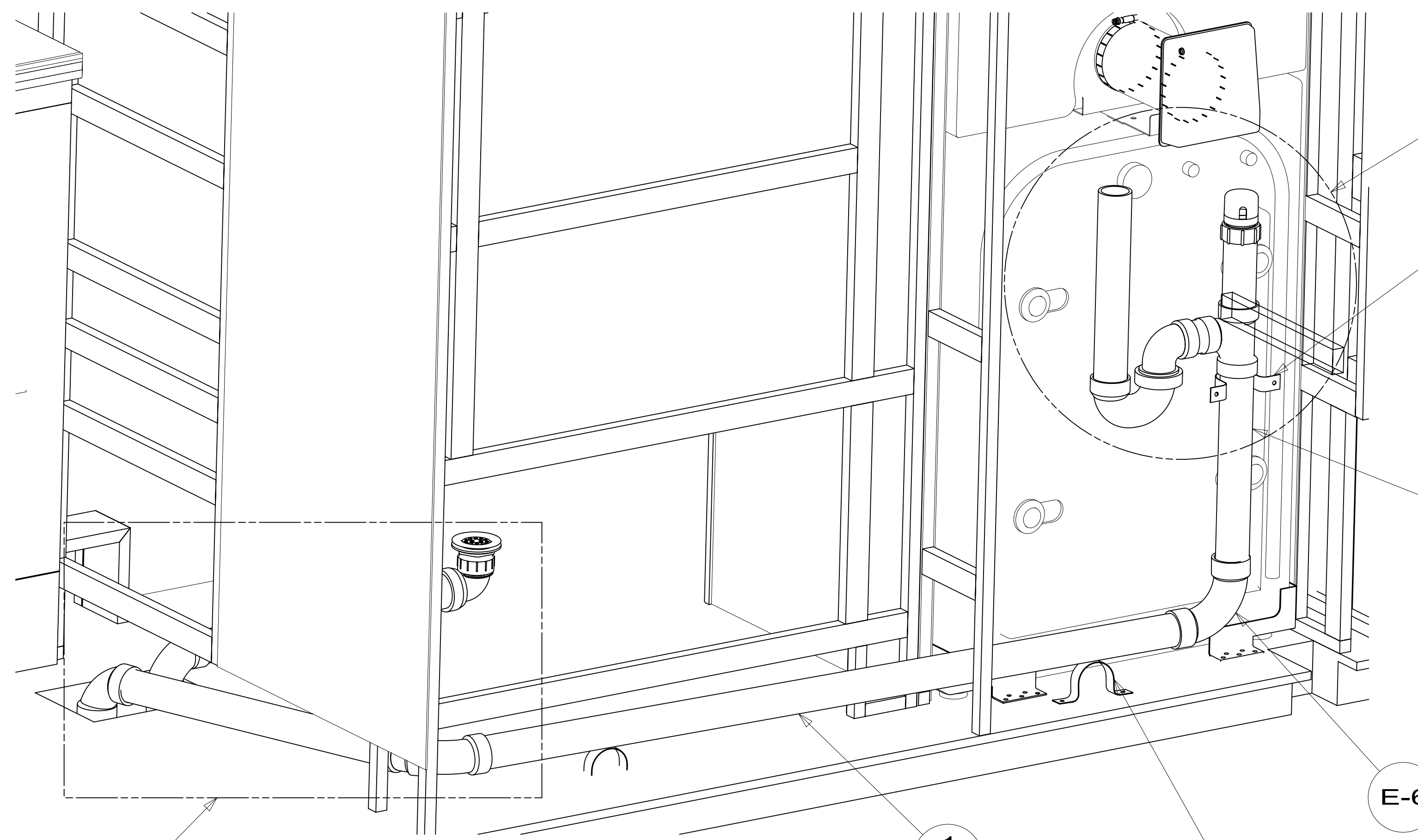

VIEW CA

DETAIL CB

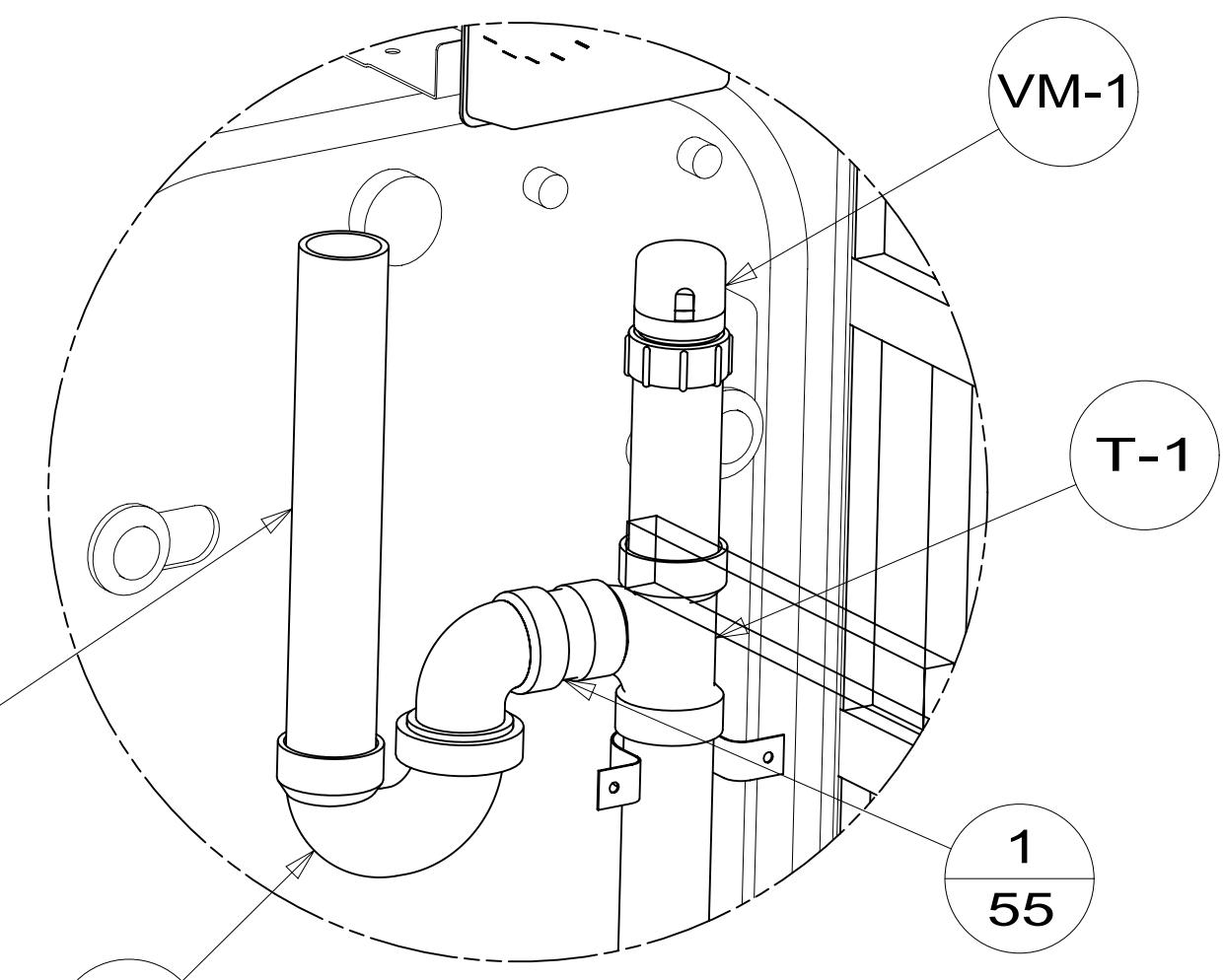

DETAIL CD
21S

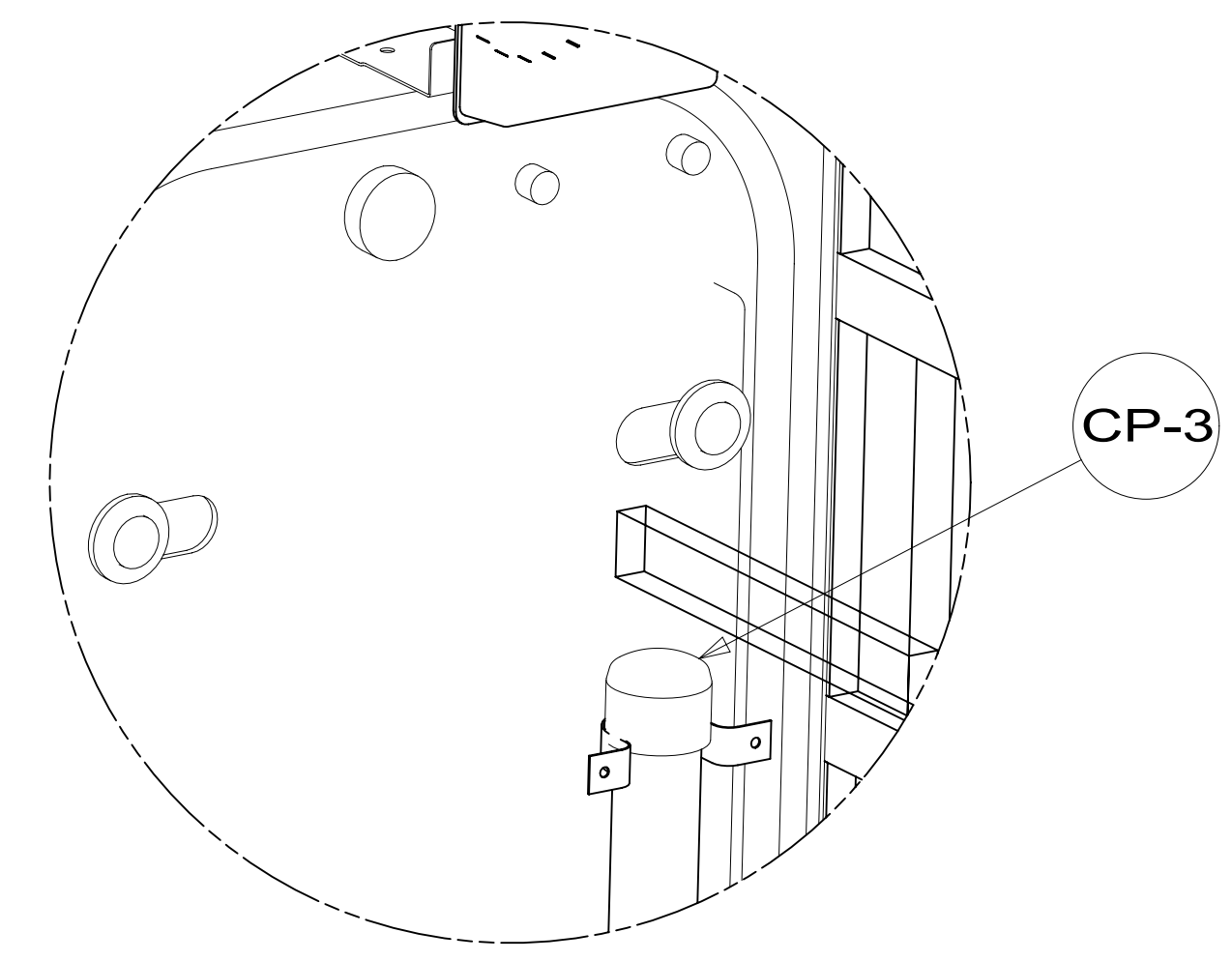

DETAIL CD
21M

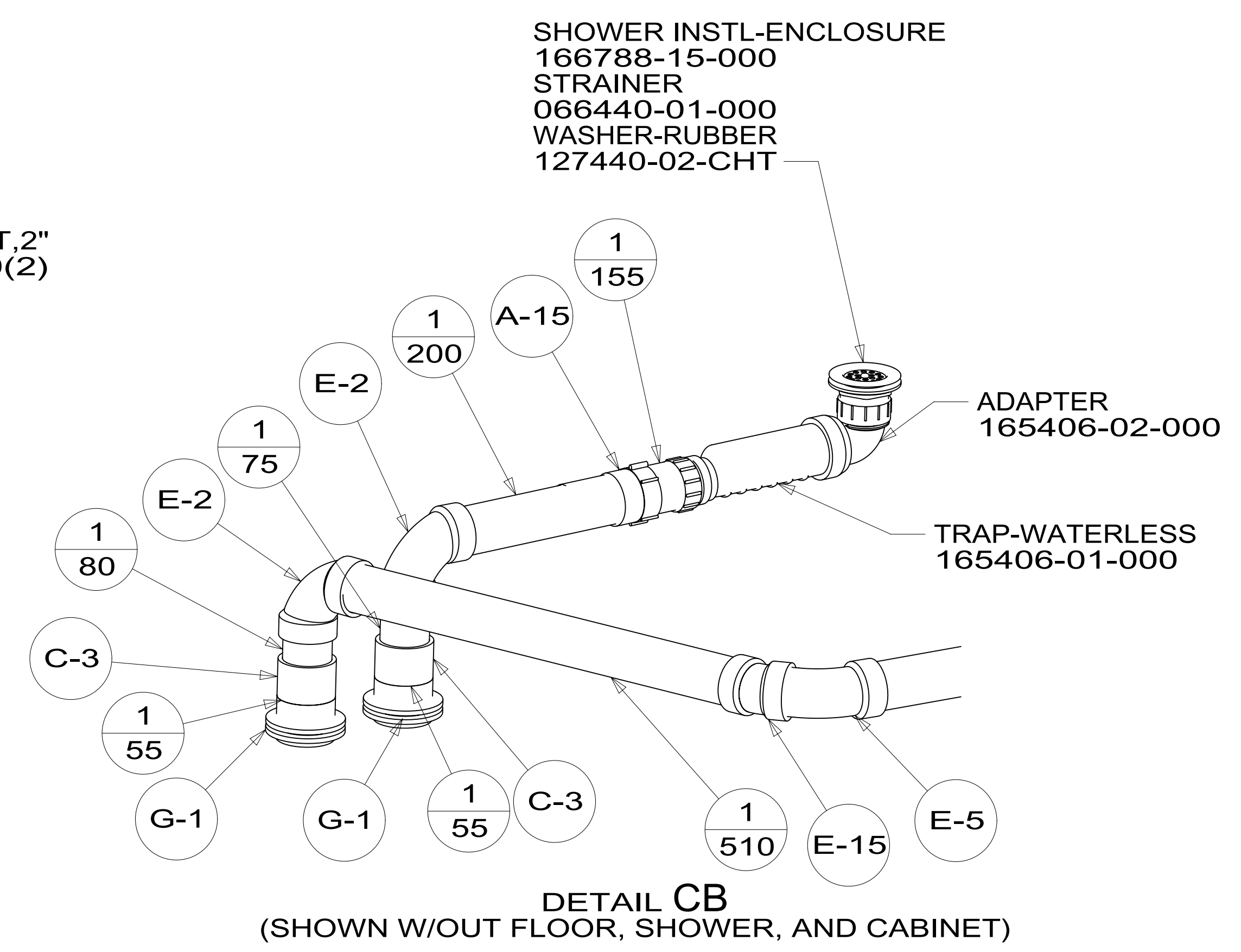

DETAIL CB
(SHOWN W/OUT FLOOR, SHOWER, AND CABINET)

FIRST USED	14 E36Y
DO NOT SCALE DRAWING	
TITLE: DRAINAGE SYSTEM INSTL	
SHEET 3	PART NO 186420 REV
1 08-Jul-2015	

186420

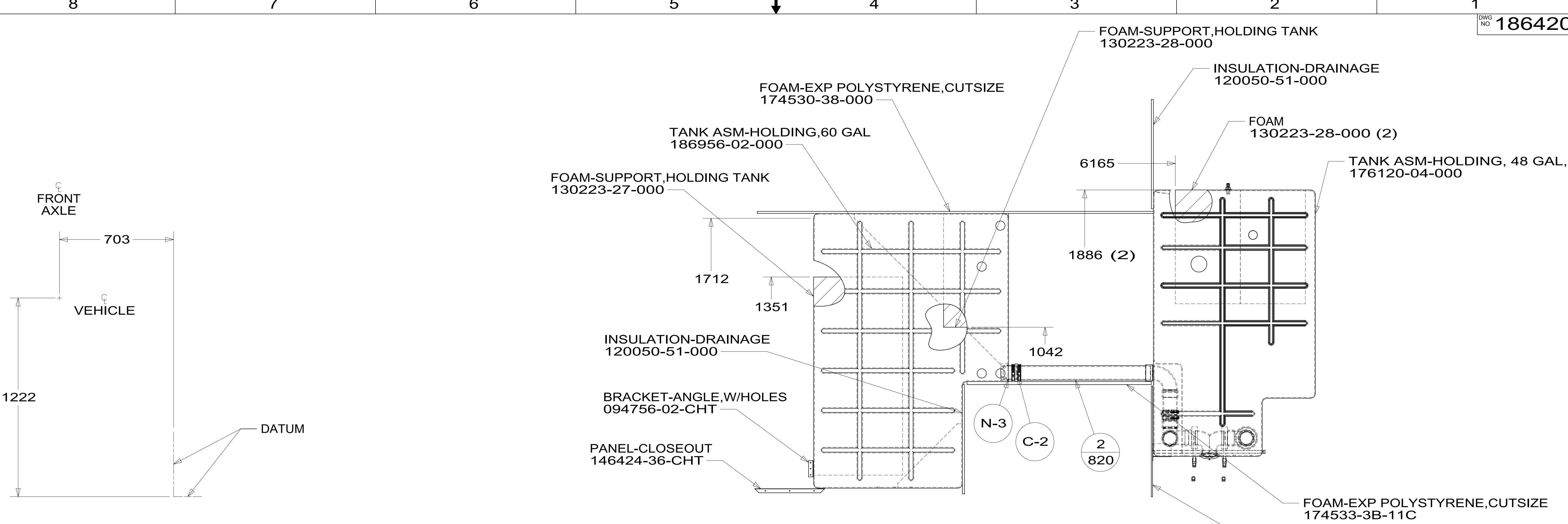

SHOWING TANKS AND DRAINS UNDER FLOOR

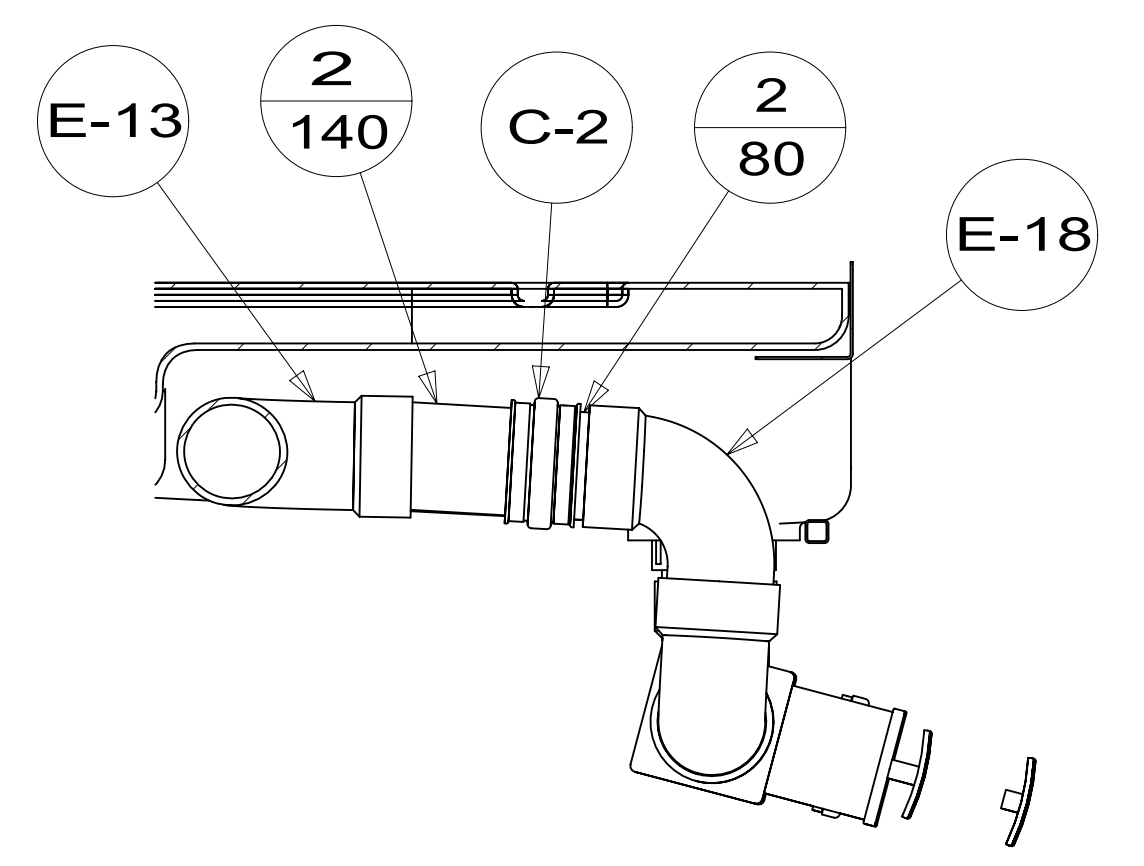

SECTION DB-DB

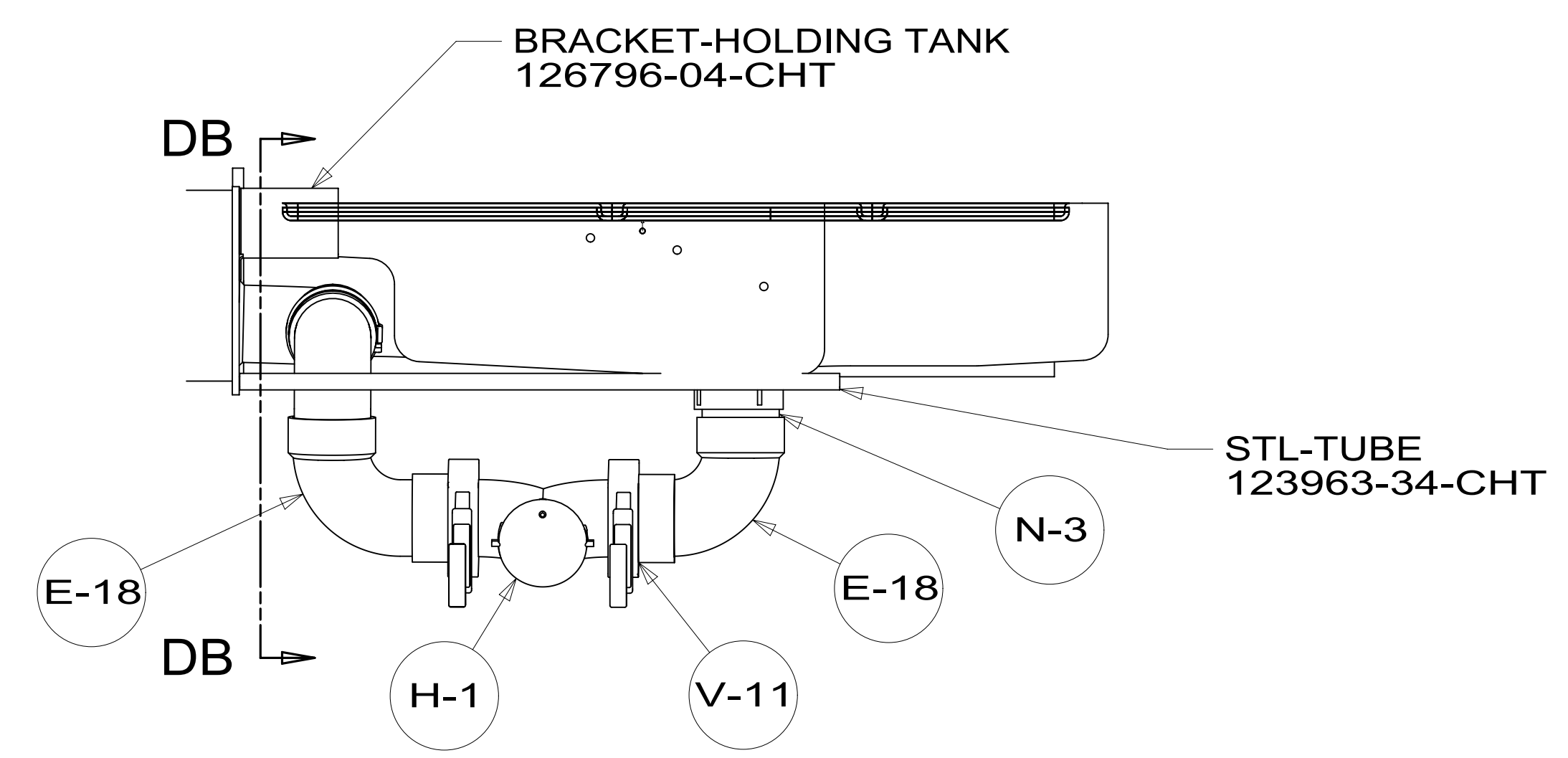

VIEW DA (SHOWN W/OUT PANEL ASM)

FIRST USED	14 E36Y		
TITLE:	DO NOT SCALE DRAWING		
SHEET	4	PART NO	186420
REV			
		1	08-Jul-2015

186420

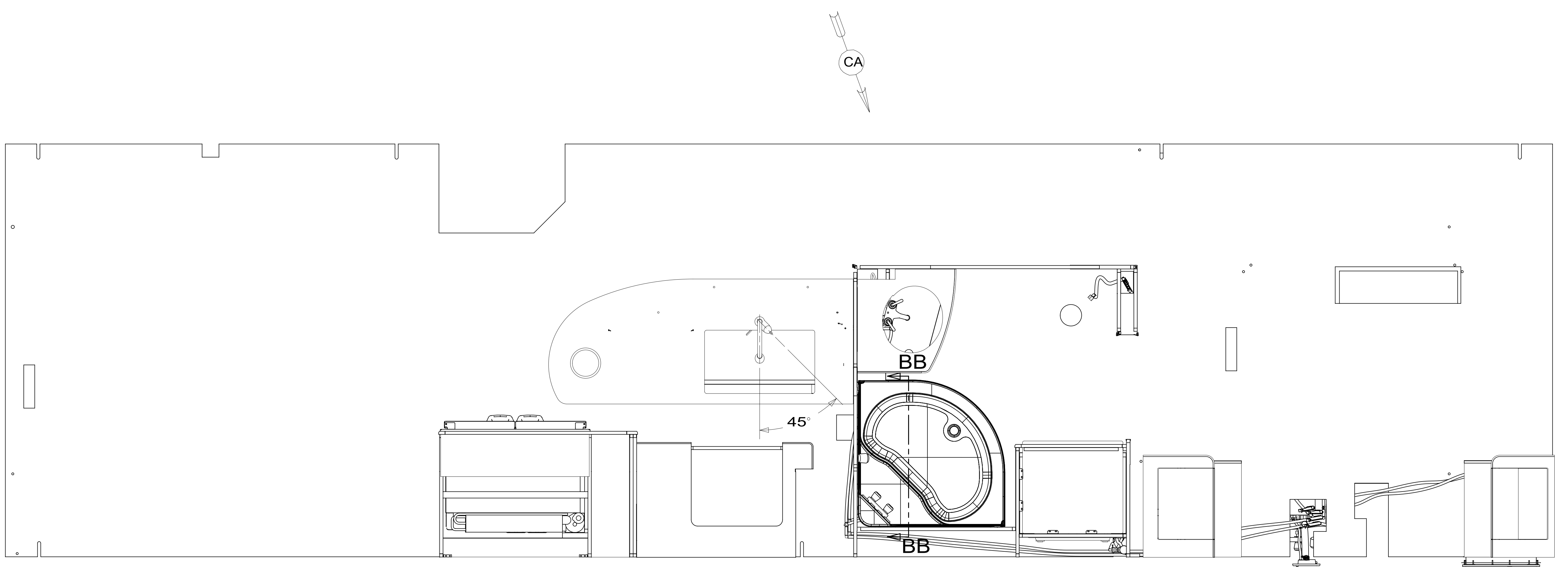

- NOTES:
9. VALVE MUST REMAIN OPEN AFTER WATER TEST.
 8. ALL CRIMP FITTINGS TO PEX TUBING REQUIRE 1/2" CLAMP 140171-03-000.
 7. ALL CRIMP FITTINGS TO PEX TUBING REQUIRE 5/8" CLAMP 140171-04-000.
 6. LABEL HOT AND COLD SUPPLY TUBES AND TAPE FITTING TO TUBE BEFORE CABINET SET TO PREVENT MOVEMENT.
 5. ADD PIPE WRAP (LADDER SCRAP 110157-02-000) INSULATION.
 4. ADD TEFLON TAPE 010405-02-000.
 3. ALL TUBING TO BE SECURED AT 1200 INTERVALS MAXIMUM WITH CLAMP 010495-01-000 AND SCREW 000G67-10-12U OR EQUIVALENT.
 2. TUBING TO BE INSTALLED WITH SUFFICIENT SLOPE TO PROVIDE DRAINAGE TO NEAREST VALVE.
 1. PLASTIC FITTINGS TO BE SEALED WITH SEALANT 084456-01-000.

- (21S) WASHER & DRYER-PAIR
- (21M) WASHER/DRYER PREP
- (15L) RESIDENTIAL REFRIGERATOR PKG
- (79W) REFRIGERATOR-4 DOOR

WINNEBAGO INDUSTRIES, INC. COPYRIGHT 2014

DFTR	ORIG. DATE
CHKR	ALL DIMENSIONS ARE IN MILLIMETERS
P.E.	
M.E.	FIRST USED
DSNR	14 E36Y

UNSPECIFIED TOLERANCES ARE:

WHOLE DIM (X)	: 3
ONE-PLACE (X.X)	: 1.5
TWO-PLACE (X.XX)	: 0.50
ANGLE	: 1°

THIRD ANGLE PROJECTION

DO NOT SCALE DRAWING REFER TO ES0018 FOR FASTENER TIGHTENING GUIDELINES

TITLE: **WATER SYSTEM INSTL**

SHEET 1 OF 5 PART NO **186418** REV

REF: 1 08-Jul-2015

(X-X)
FOR WATER CALLOUTS SEE DWG NO 116230-01-000

*186418 *A

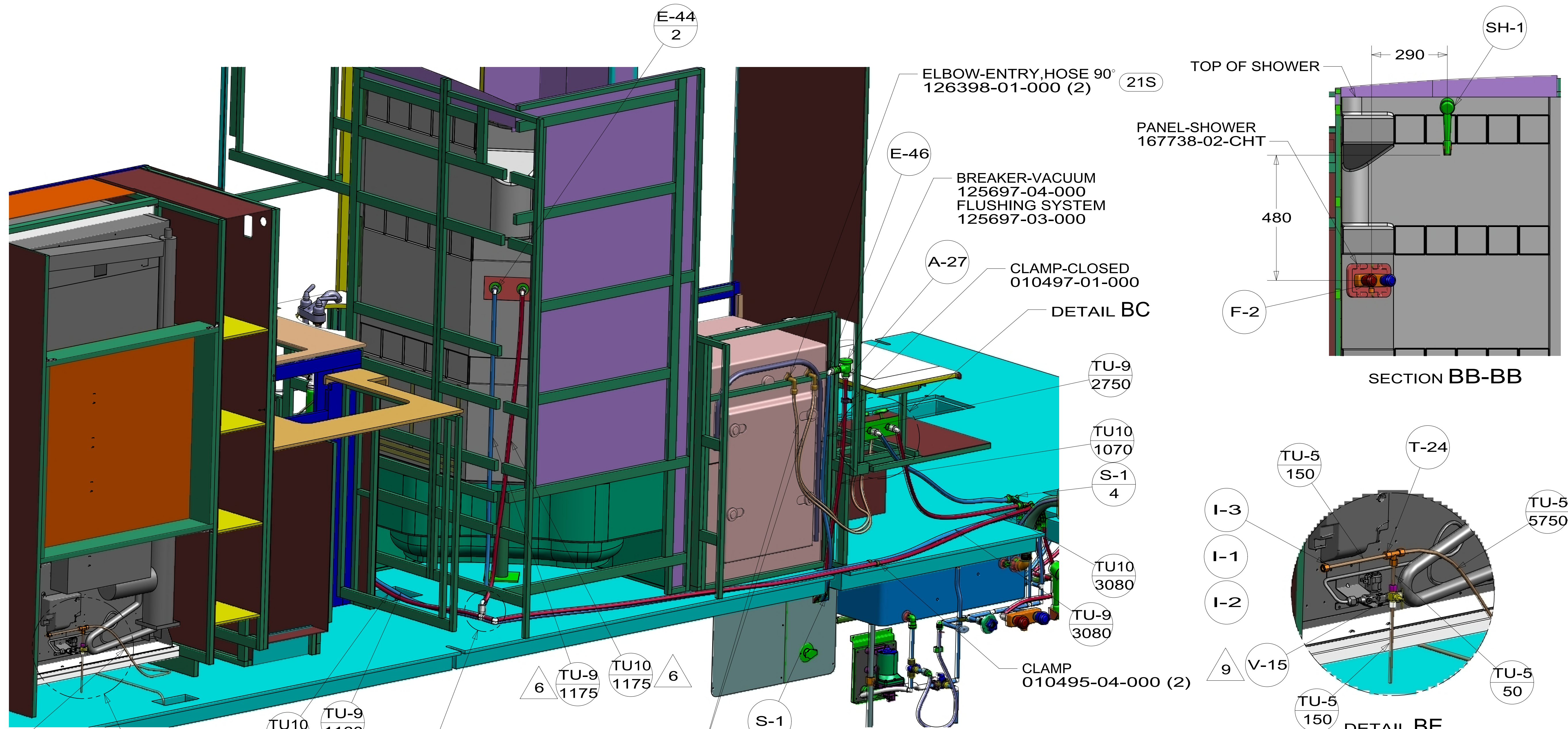

FIRST USED	14 E36Y
DO NOT SCALE DRAWING	
TITLE: WATER SYSTEM INSTL	
SHEET 2	PART NO 186418 REV
1 08-Jul-2015	

186418

WATER HEATER INSTL
186899-01-000
CABLE ASM
076767-03-000

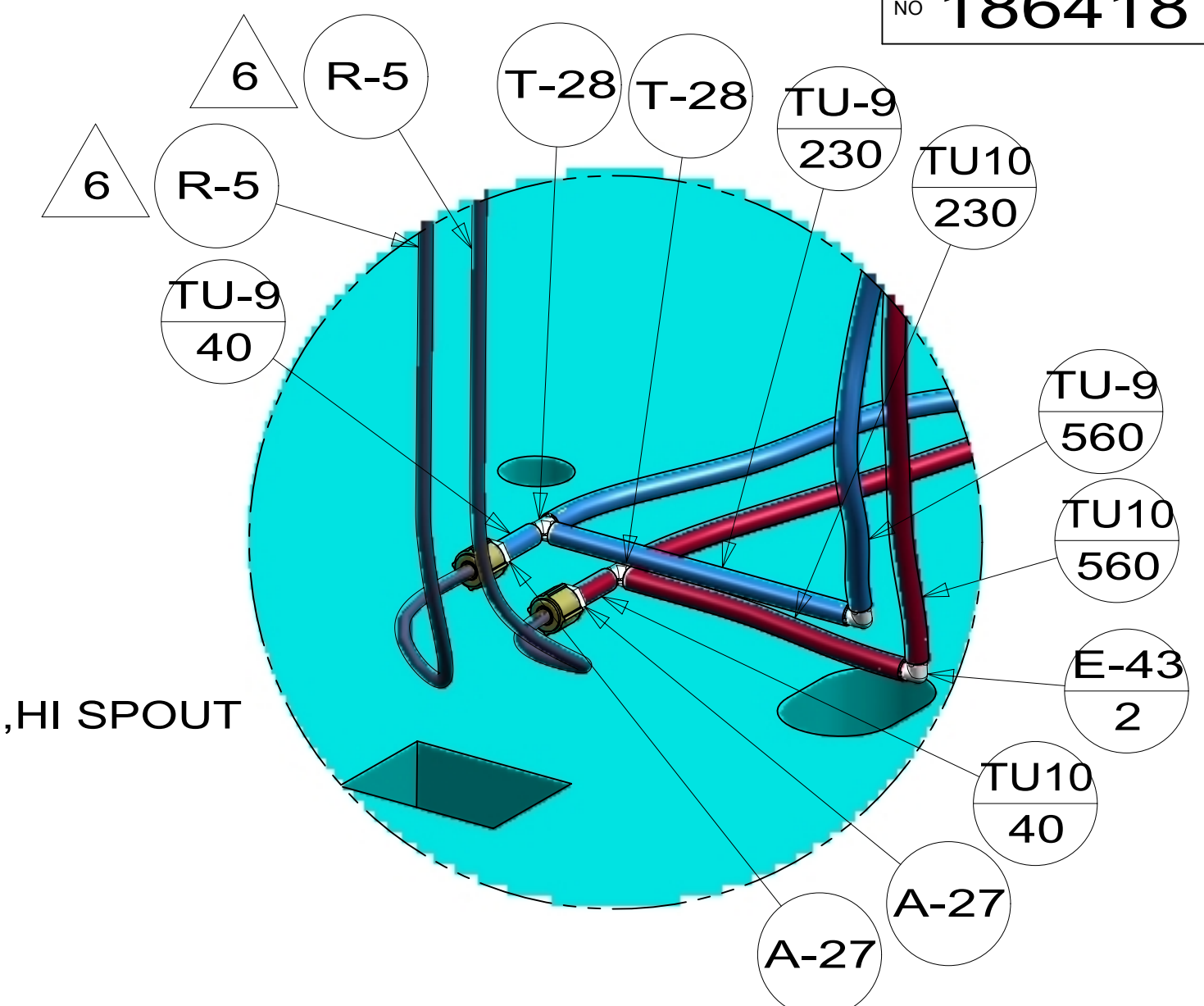
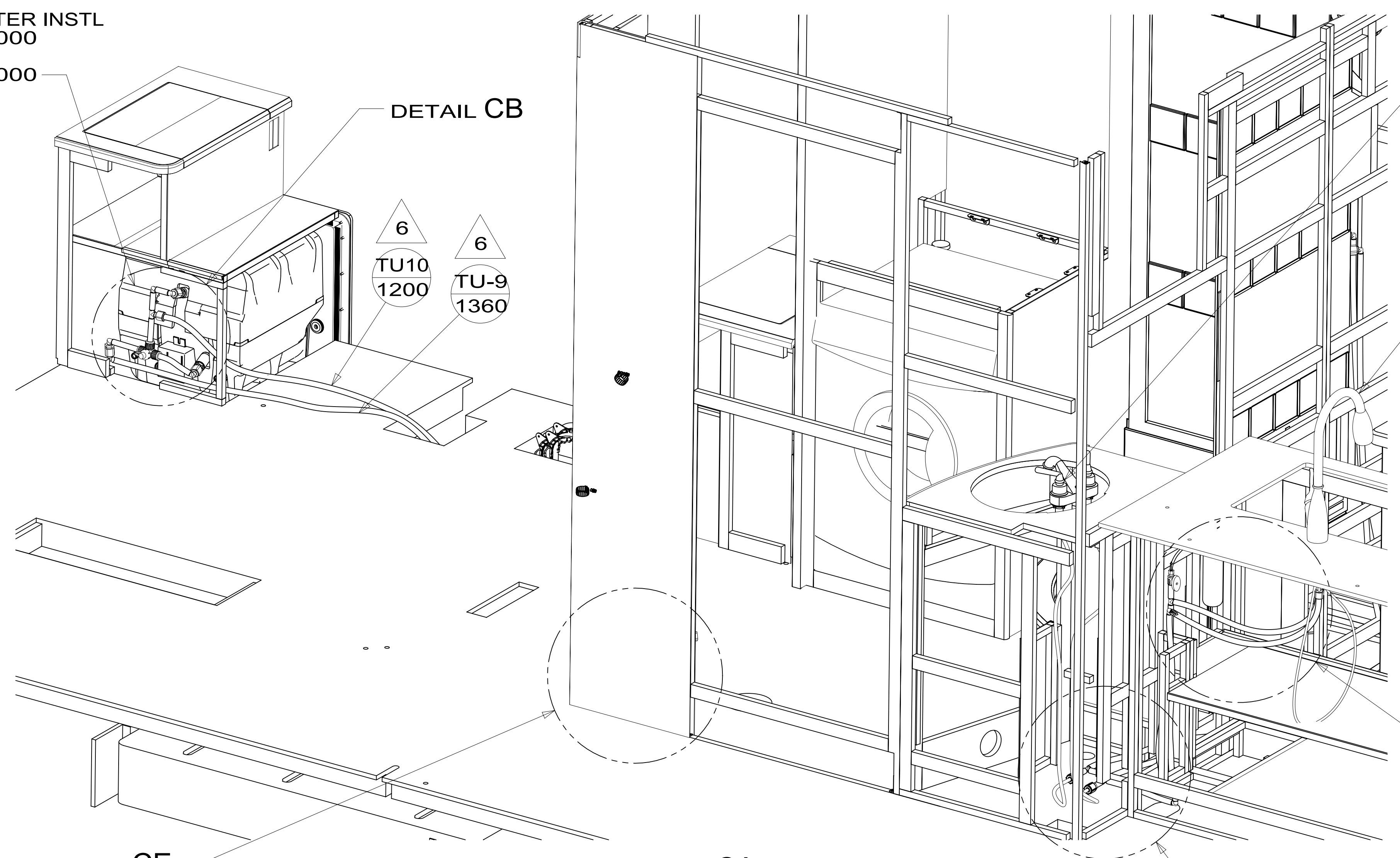

DETAIL CD
(SHOWN W/OUT CABINETS)

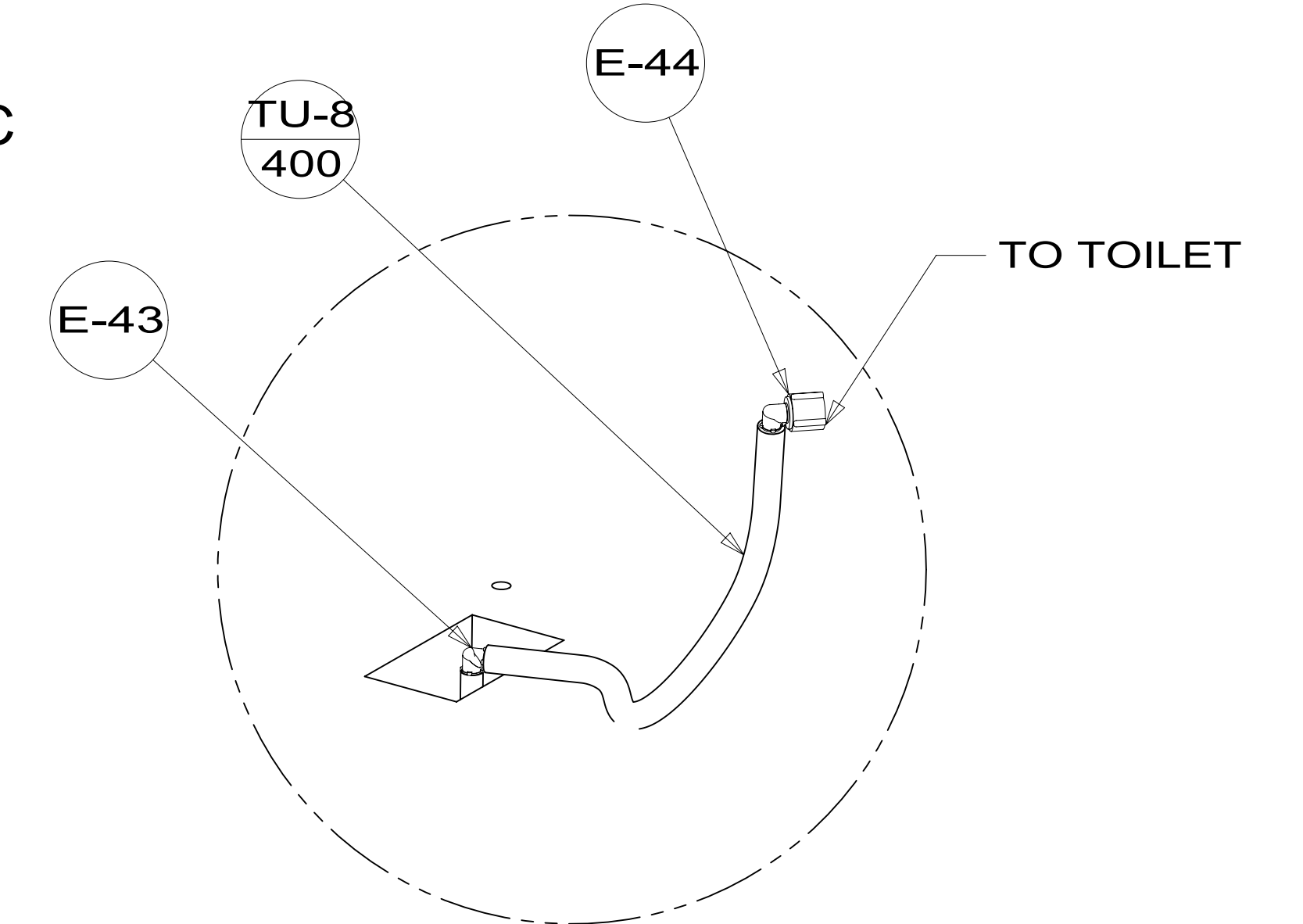

DETAIL CE
(SHOWN W/OUT CABINETS)

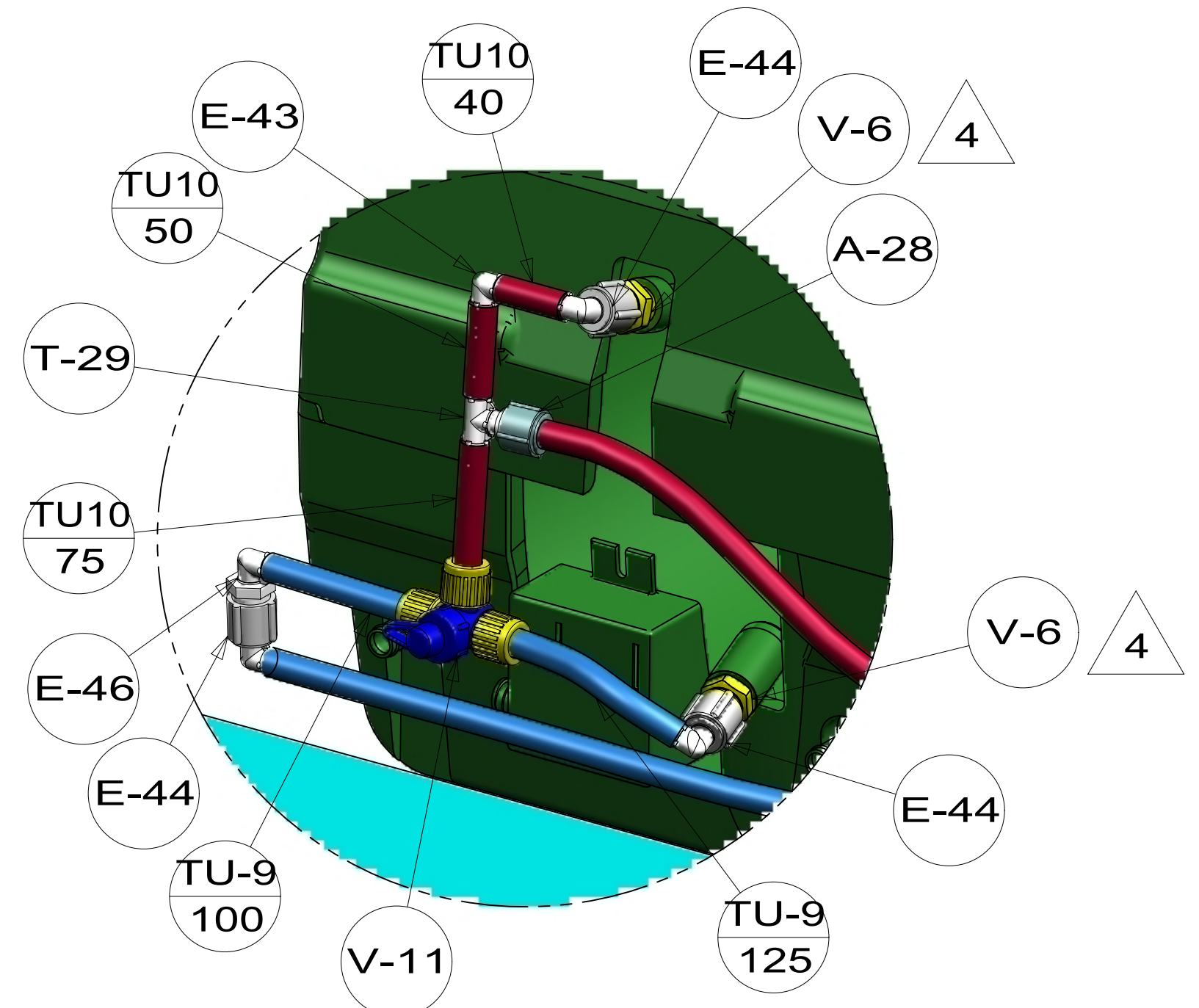

DETAIL CB
(SHOWN W/OUT CABINETS)

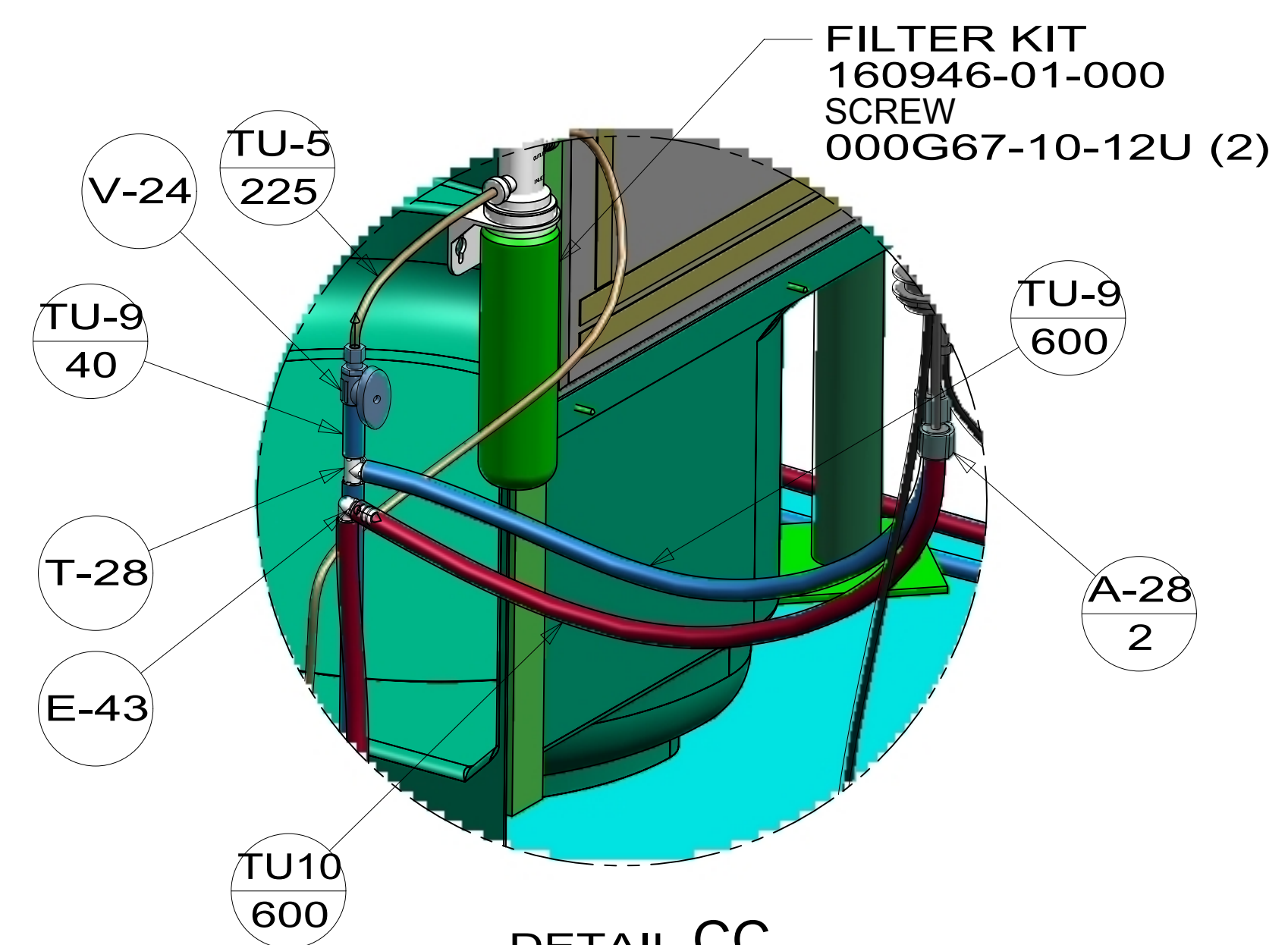

DETAIL CC
(SHOWN W/OUT CABINETS)

FAUCET-LAV
186417-01-CHT

FAUCET-GAL,SGL CNTL,HI SPOUT
193458-01-CHT

FIRST USED	14 E36Y
DO NOT SCALE DRAWING	
TITLE: WATER SYSTEM INSTL	
SHEET 3	PART NO 186418 REV
1 08-Jul-2015	

186418

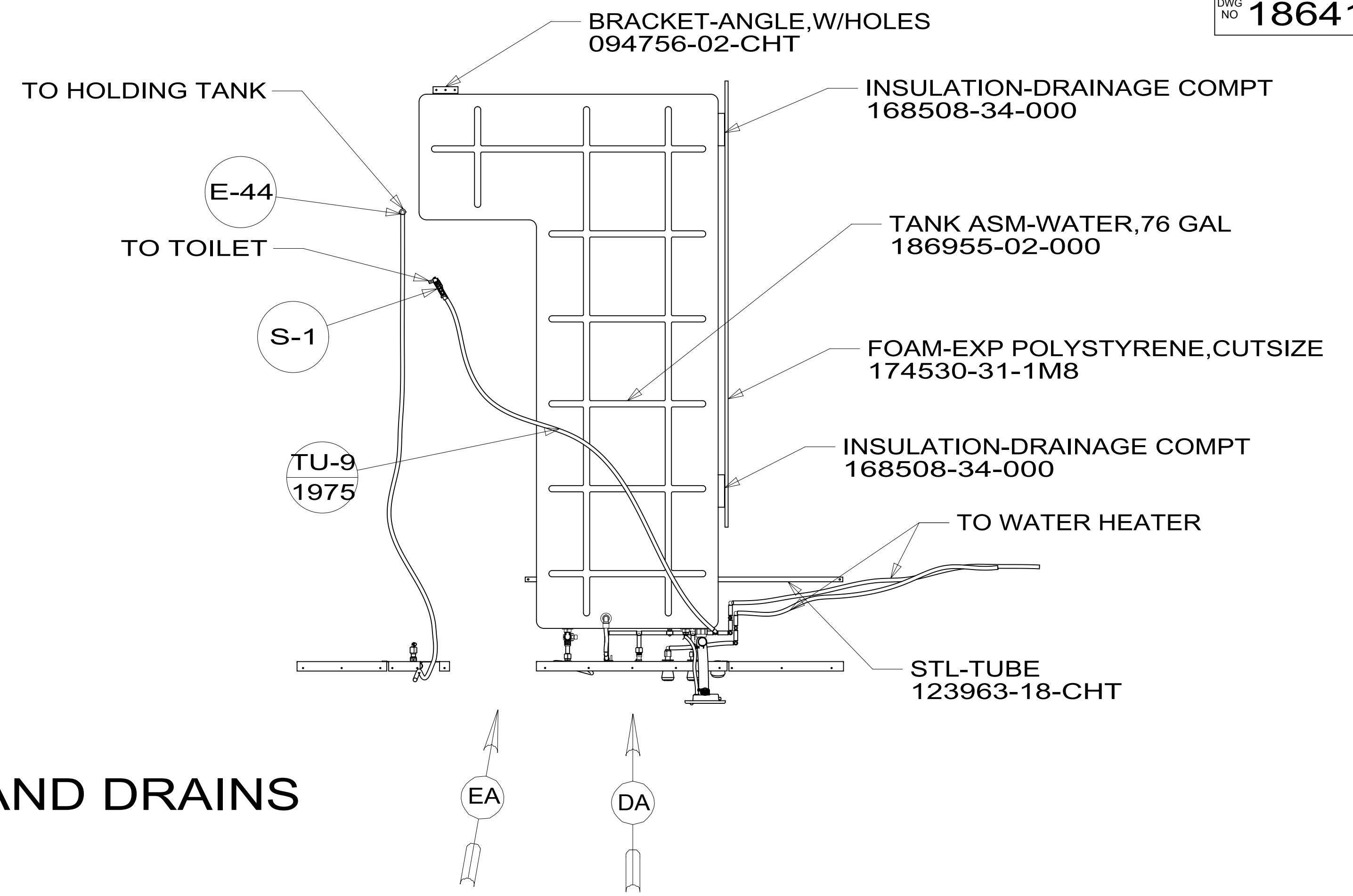
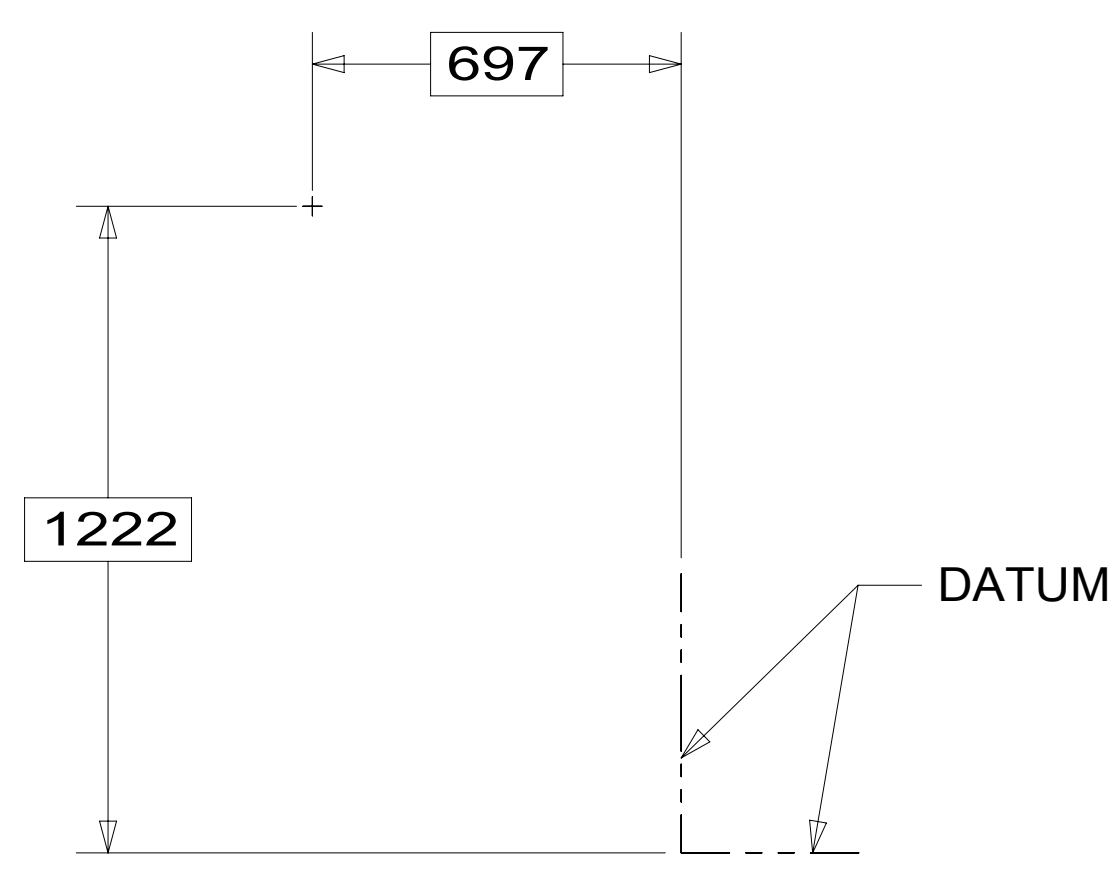

SHOWING ONLY TANKS AND DRAINS

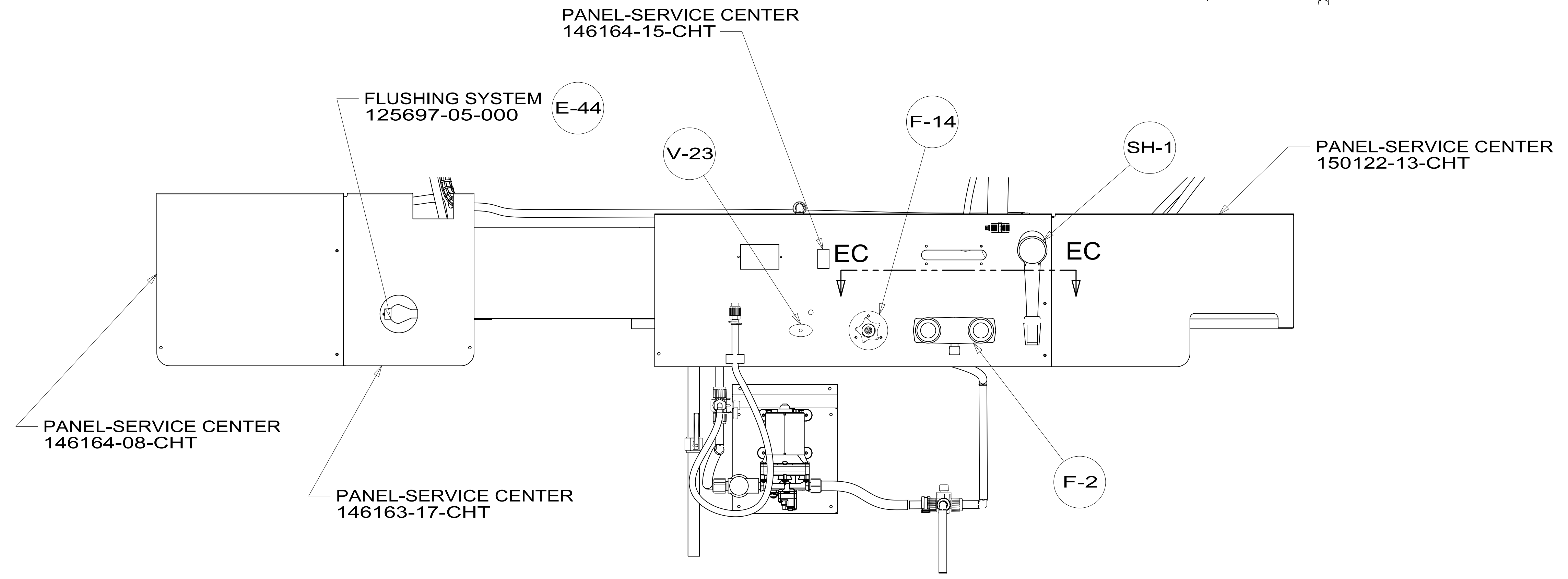

VIEW DA

FIRST USED	14 E36Y	
DO NOT SCALE DRAWING		
TITLE: WATER SYSTEM INSTL		
SHEET 4	PART NO 186418	REV
		1 08-Jul-2015

*186418 *A

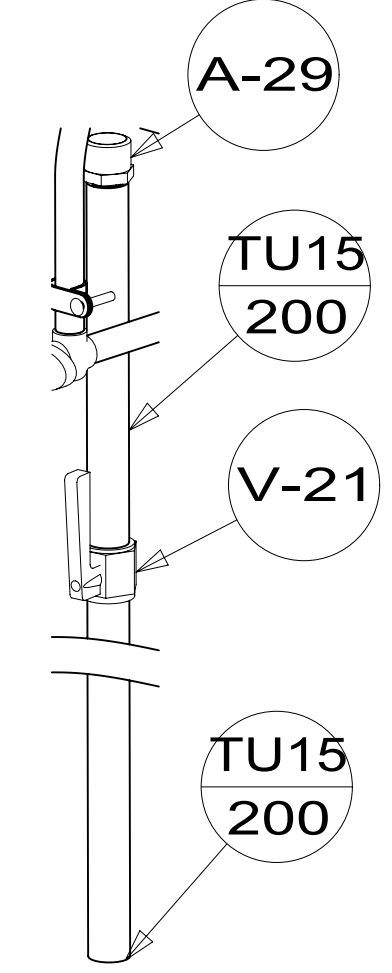
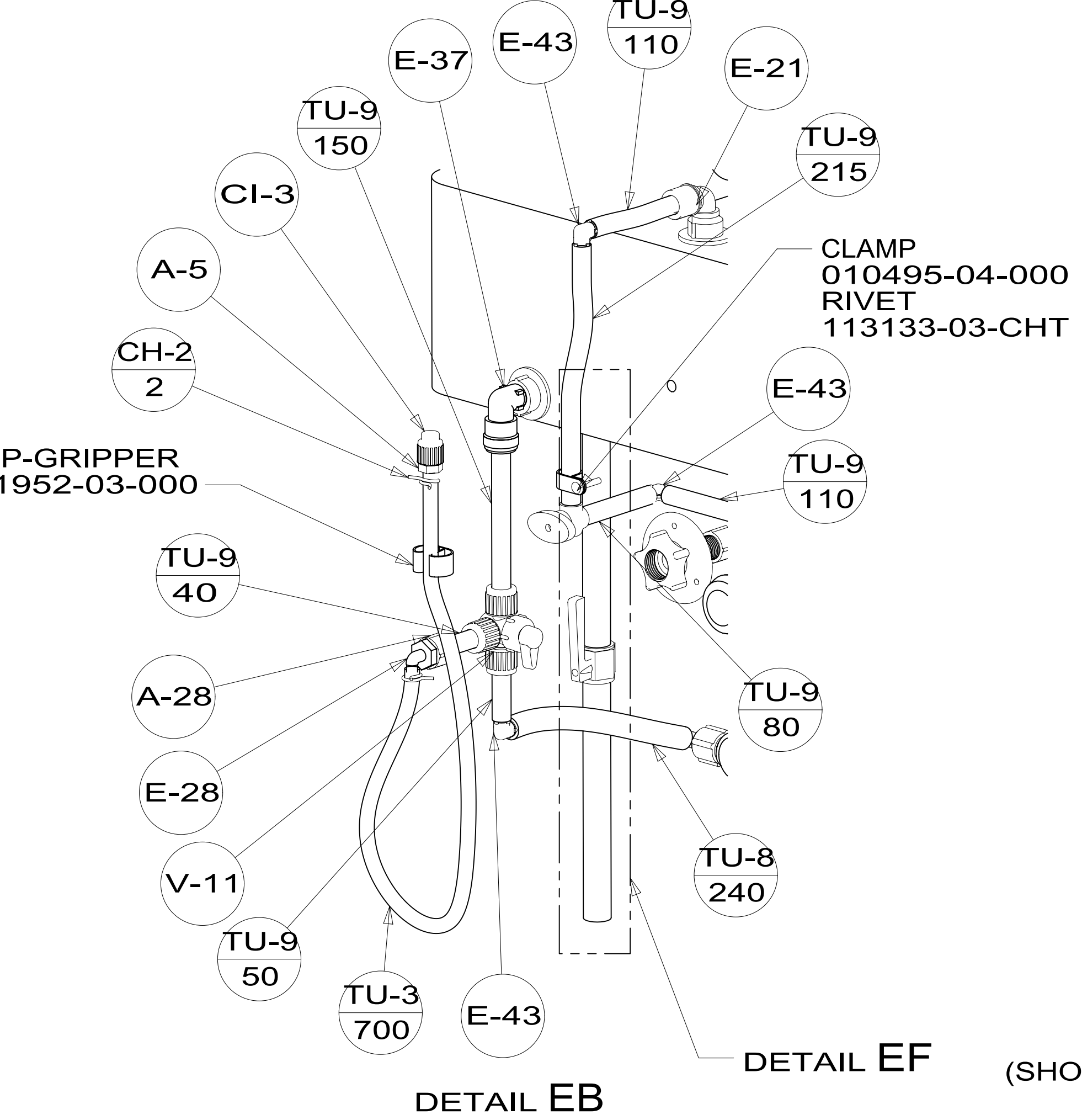
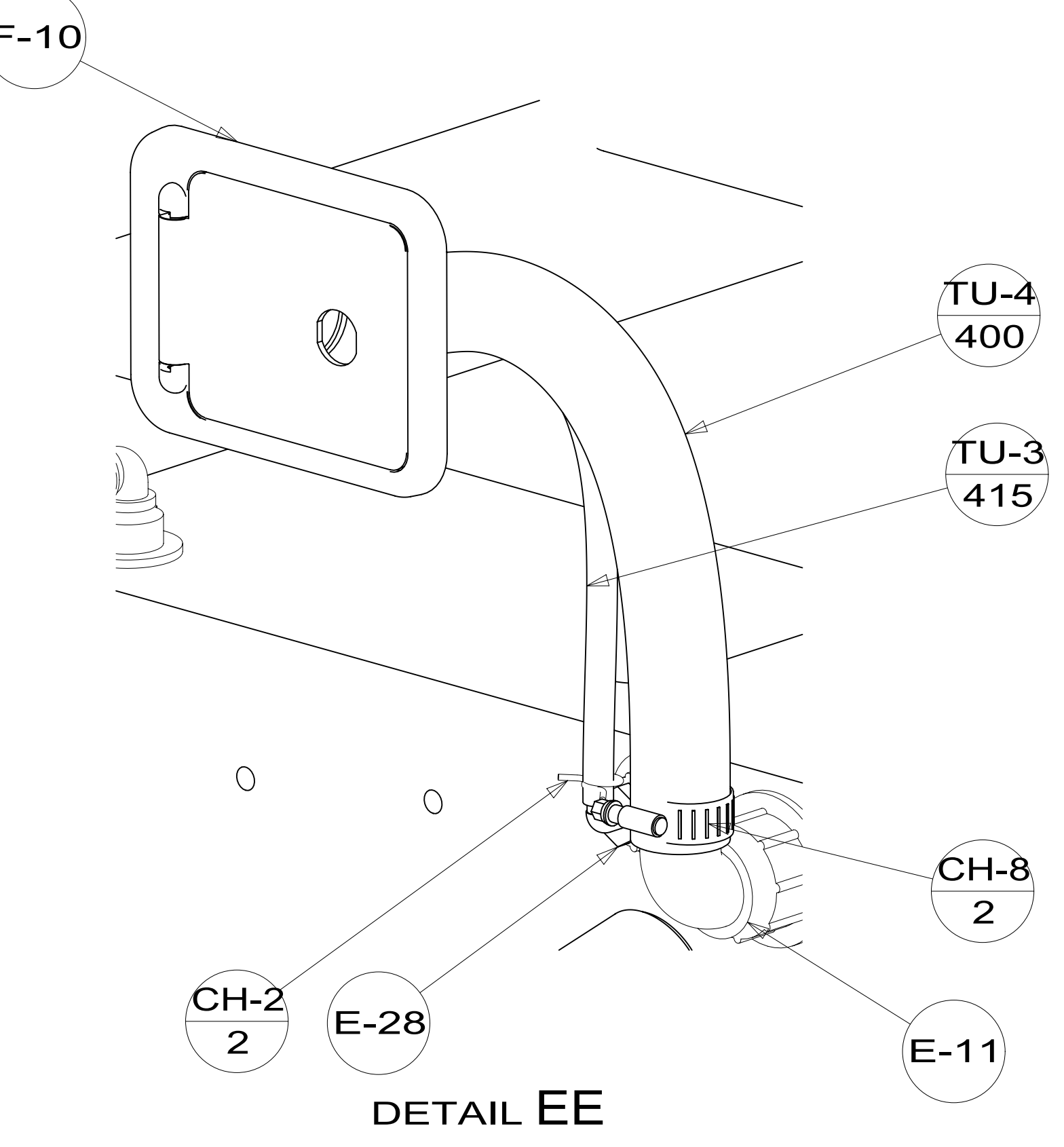
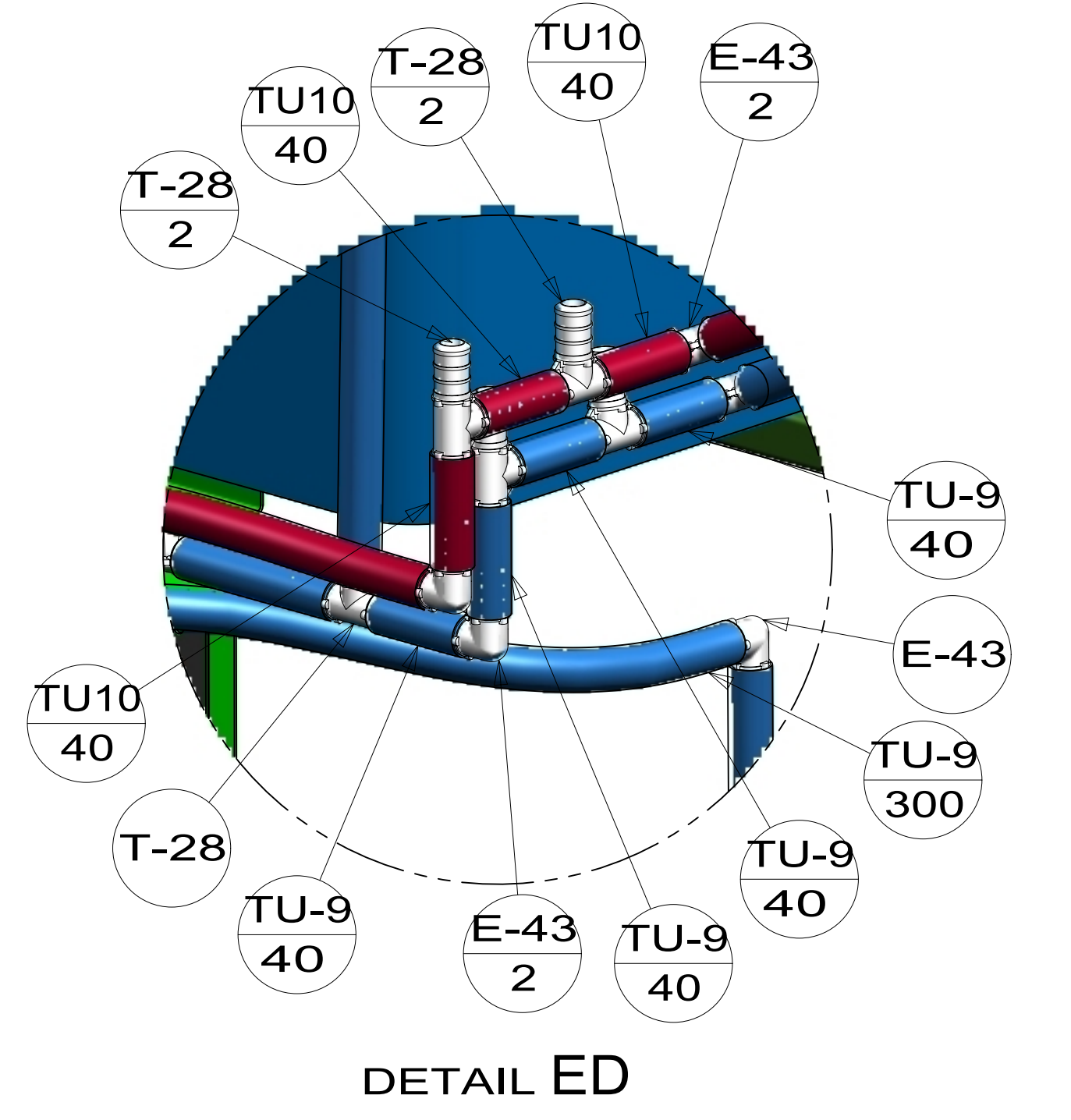
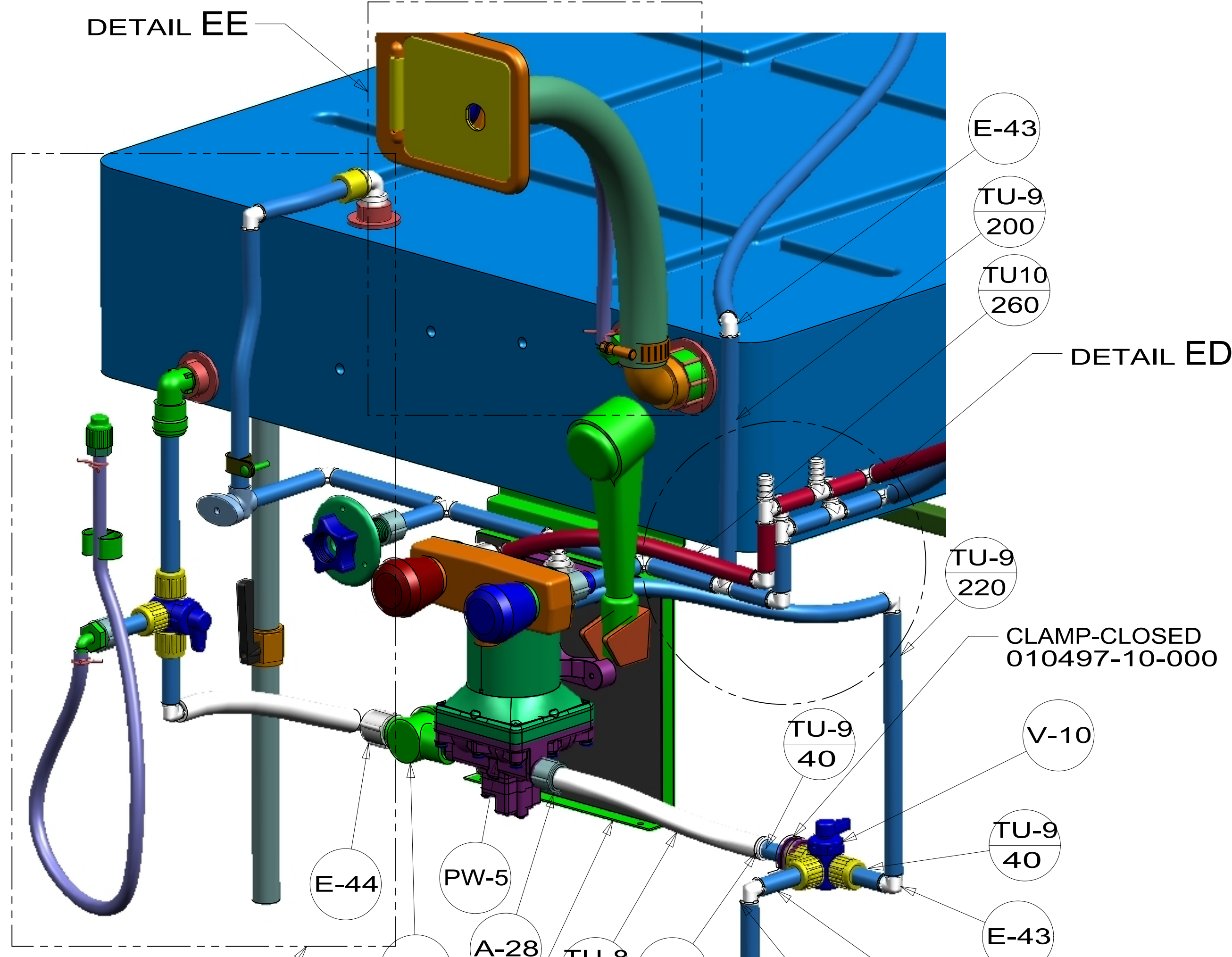

BRACKET-PUMP WATER 169229-01-CHT
 PANEL-WATER PUMP 149477-08-CHT
 FOAM-PAD 140364-01-CHT

VIEW EA
 (SHOWN W/OUT SERVICE PANEL)

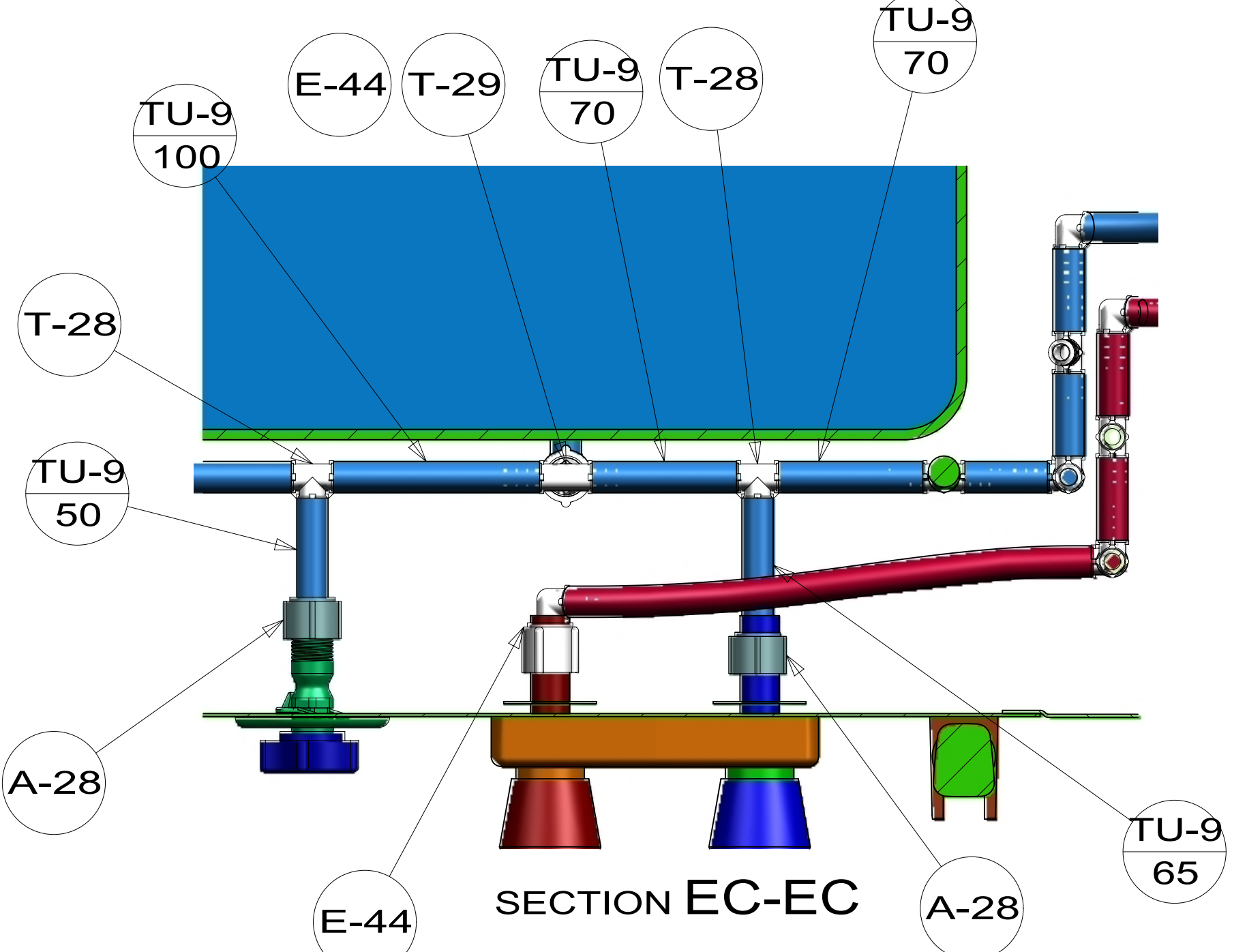

FIRST USED	14 E36Y
DO NOT SCALE DRAWING	
TITLE: WATER SYSTEM INSTL	
SHEET 5	PART NO 186418 REV
08-Jul-2015	

186418