

9. SEE DRAWING 061607 FOR INSTALLATION OF GROMMETS.
8. SECURE DRAINAGE PIPES TO CABINET USING WIRE TIE 108046-02-000, AND SCREW 000G67-10-12U AT INTERVALS OF NOT OF NOT MORE THAN 4 FEET APART.
7. SECURE VENT PIPE TO FLOOR WITH CLAMP 062401-02-000 (2), SCREW 000G67-10-12U (2), BRACKET 136878-01-CHT (2).
6. VENT PIPE MUST PROJECT 51 MIN AND 64 MAX ABOVE ROOF FOR PROPER FIT AND FUNCTION. ADD S-1 (116666-01-CHT SEAL-VENT PIPE) AROUND PIPE ON ROOF BEFORE VENT CAP IS INSTALLED.
5. SEAL AROUND SHOWER WITH SILICONE.
4. USE SMOOTH PLUMBERS PUTTY 167459-01-000 TO SEAL STRAINER (0.2 PER STRAINER).
3. ALL PIPE AND FITTINGS TO BE ASSEMBLED WITH SOLVENT 004020-01-000 (USA), 004020-02-000 (CAN)
2. SLOPE OF TRAP ARM MUST BE 6 PER 305 mm.
1. SLOPE OF HORIZONTAL PIPING TO BE MINIMUM OF 3 PER 305 mm.

NOTES:

- 265 CODES/STDS-CSA/CMVSS
- 1B1 CODES/STANDARDS-USA

WINNEBAGO		COPYRIGHT 2014 WINNEBAGO INDUSTRIES, INC.	
DFT-ORIG	ORIG. DATE		
CHKR	ALL DIMENSIONS ARE IN MILLIMETERS		
P.E.	FIRST USED		
M.E.	14 E31KE		
DSNR	MATERIAL:		
UNSPECIFIED TOLERANCES ARE:			
WHOLE DIM (X)	: 3		
ONE-PLACE (X.X)	:		
TWO-PLACE (X.XX)	:		
ANGLE	:		
THIRD ANGLE PROJECTION			
DO NOT SCALE DRAWING	REFER TO ES0018 FOR FASTENER TIGHTENING GUIDELINES		
TITLE: DRAINAGE SYSTEM INSTL			
SHEET 1 OF 3	PART NO	183852	REV
REF:	1	08-Jul-2015	

FOR
DRAINAGE
CALLOUTS
SEE DWG NO
116229-01-000

*183852 *A

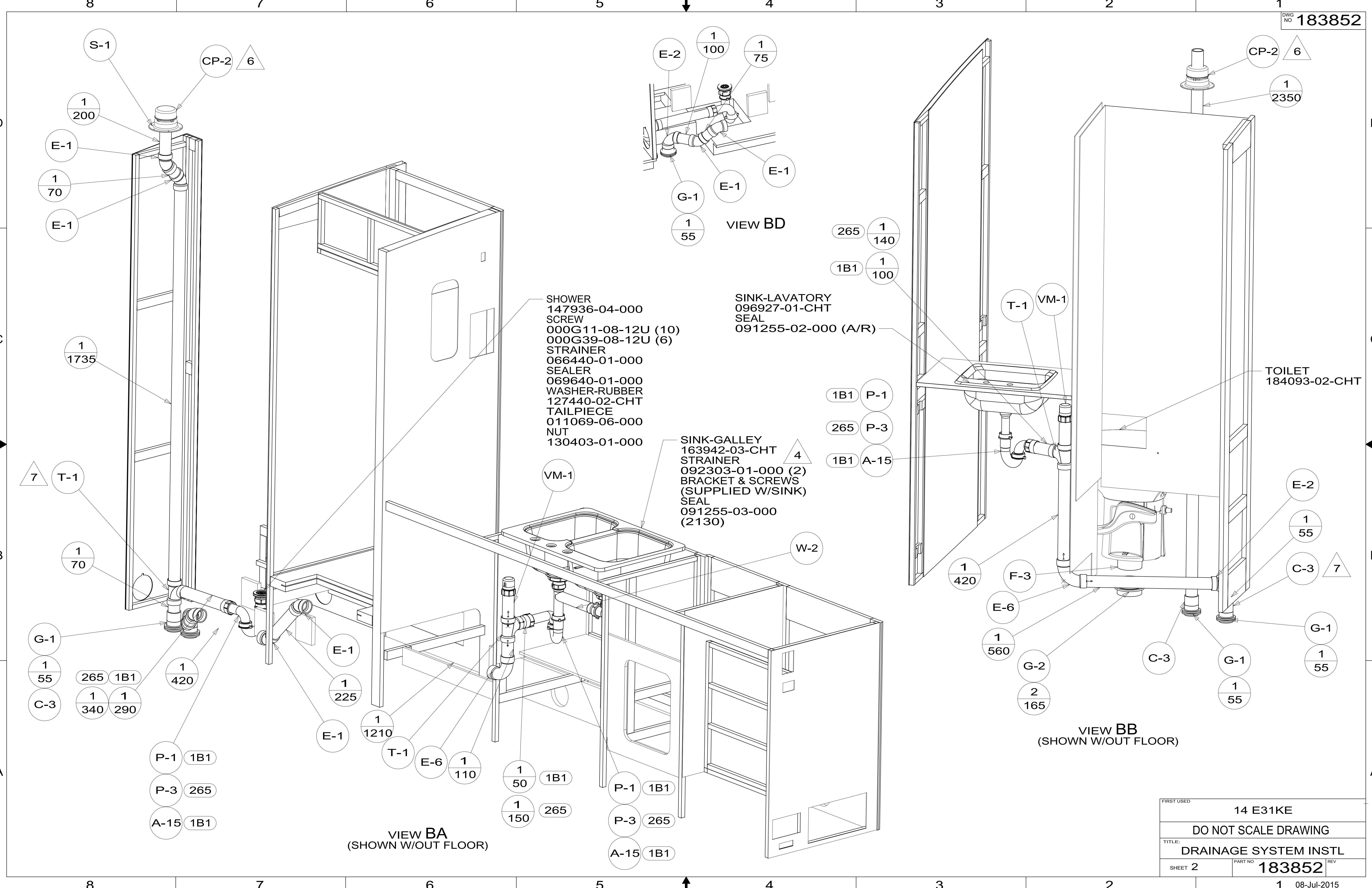

- SHOWER
 147936-04-000
 SCREW
 000G11-08-12U (10)
 000G39-08-12U (6)
 STRAINER
 066440-01-000
 SEALER
 069640-01-000
 WASHER-RUBBER
 127440-02-CHT
 TAILPIECE
 011069-06-000
 NUT
 130403-01-000

- SINK-LAVATORY
 096927-01-CHT
 SEAL
 091255-02-000 (A/R)

- SINK-GALLEY
 163942-03-CHT
 STRAINER
 092303-01-000 (2)
 BRACKET & SCREWS
 (SUPPLIED W/SINK)
 SEAL
 091255-03-000
 (2130)

TOILET
 184093-02-CHT

VIEW BA
 (SHOWN W/OUT FLOOR)

VIEW BD

VIEW BB
 (SHOWN W/OUT FLOOR)

FIRST USED	14 E31KE	
TITLE:	DO NOT SCALE DRAWING	
TITLE:	DRAINAGE SYSTEM INSTL	
SHEET 2	PART NO	183852
	REV	1
		08-Jul-2015

183852

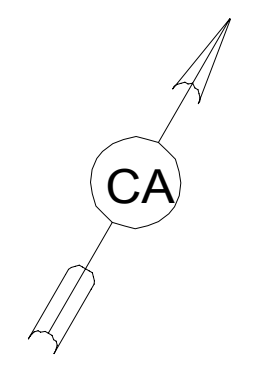
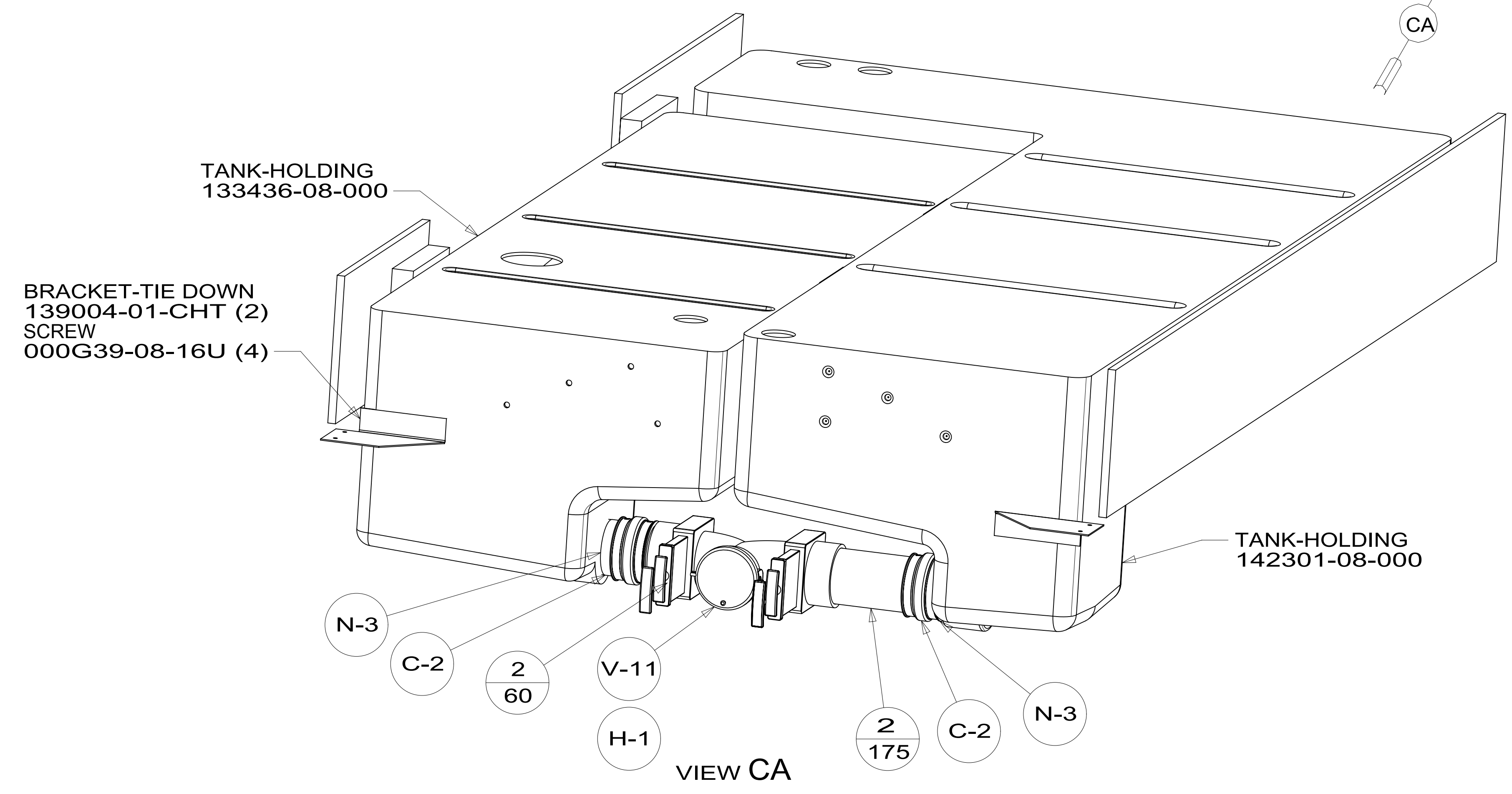
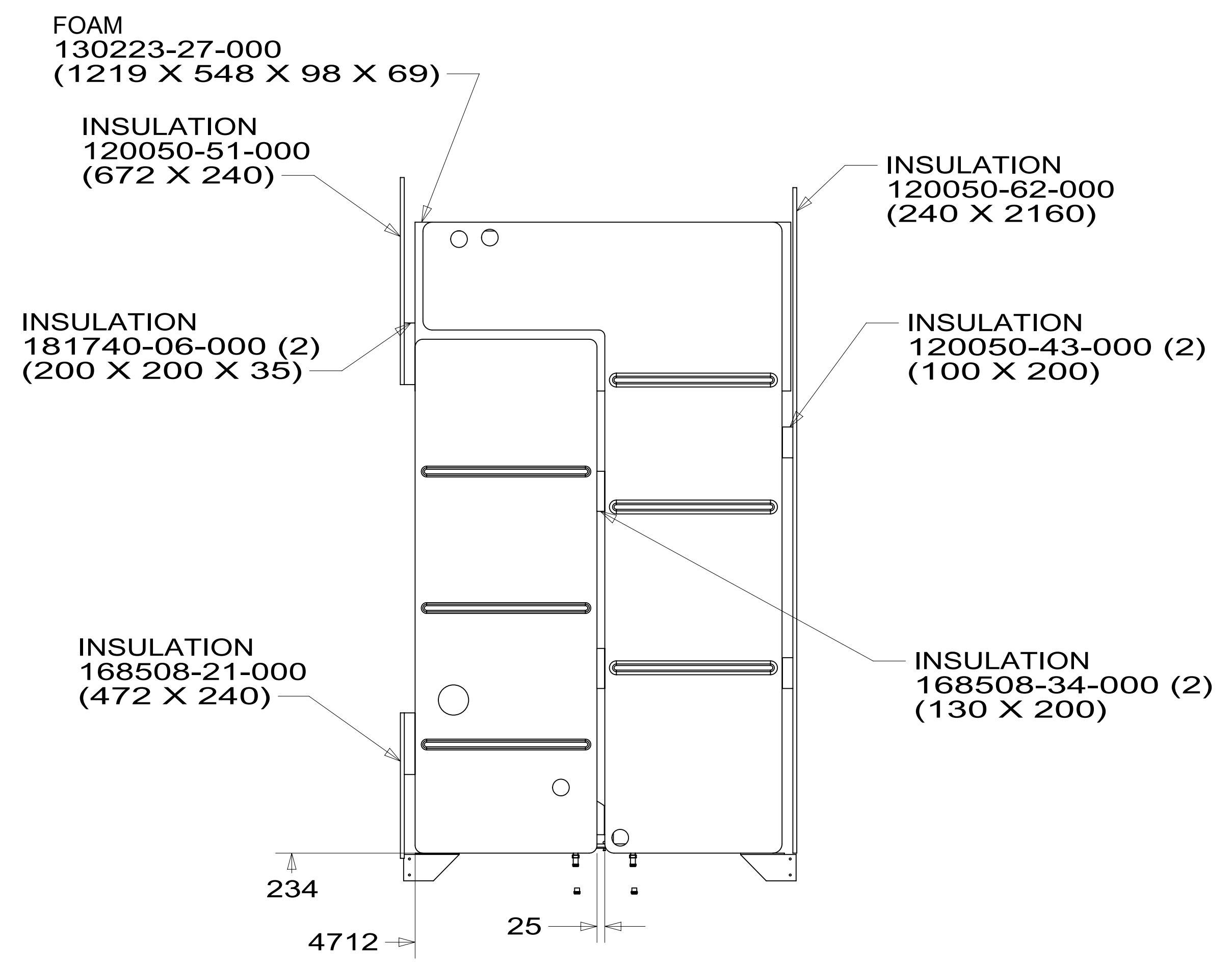
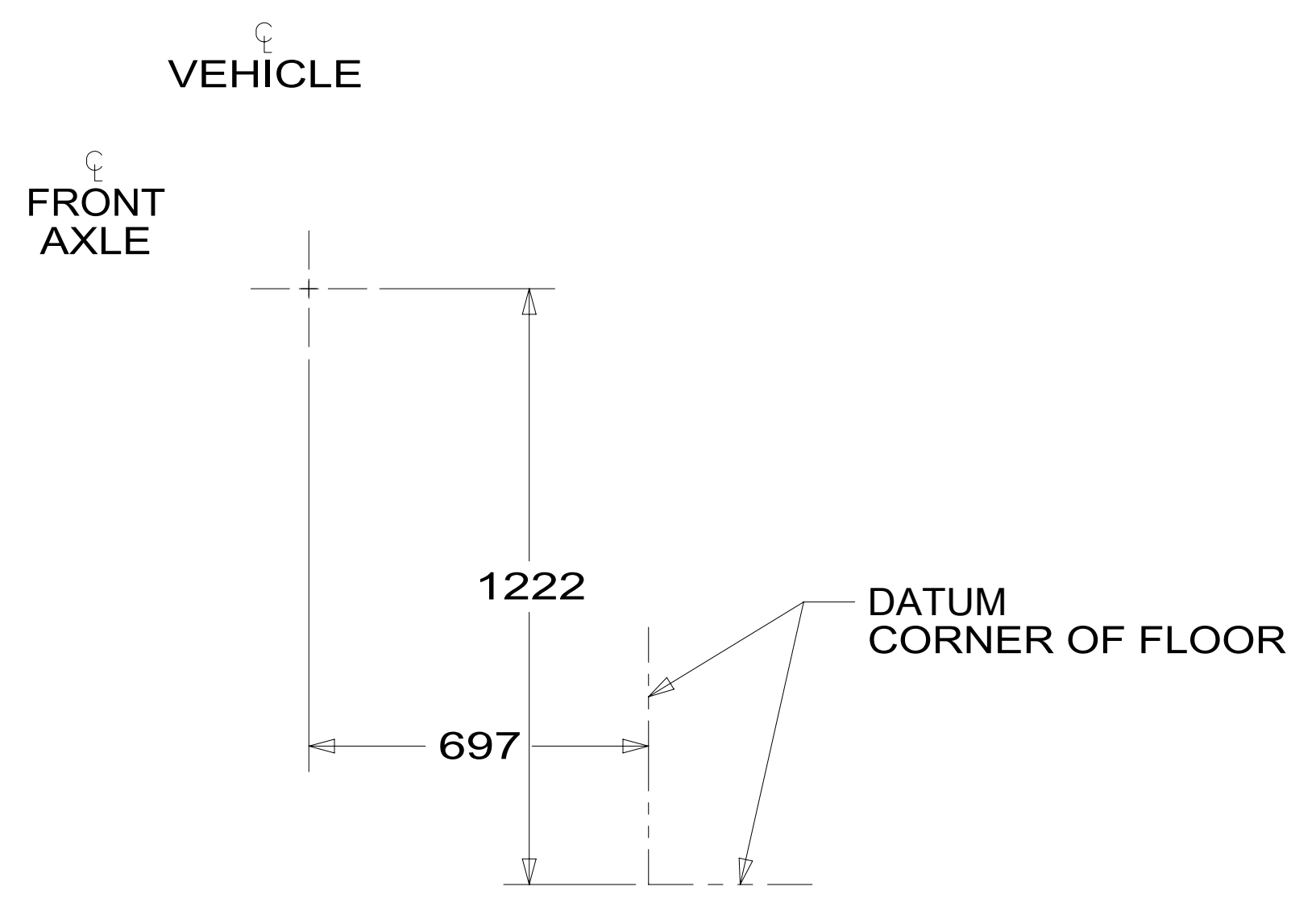

FIRST USED	14 E31KE	
DO NOT SCALE DRAWING		
TITLE: DRAINAGE SYSTEM INSTL		
SHEET 3	PART NO 183852	REV
		1 08-Jul-2015

*183852 *A

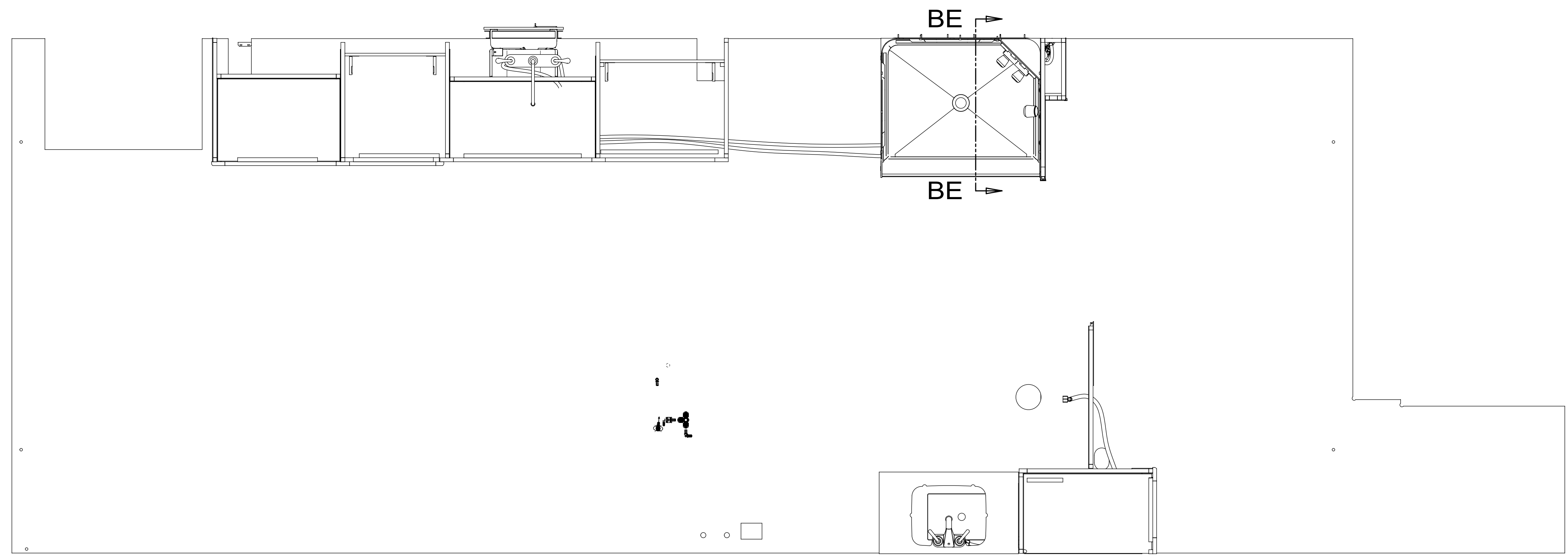

- NOTES:
1. PLASTIC FITTINGS TO BE SEALED WITH SEALANT 084456-01-000.
 2. TUBING TO BE INSTALLED WITH SUFFICIENT SLOPE TO PROVIDE DRAINAGE TO NEAREST VALVE.
 3. ALL TUBING TO BE SECURED AT 1200 INTERVALS MAXIMUM WITH CLAMP 010495-01-000 AND SCREW 000G67-10-12U OR EQUIVALENT.
 4. ADD TEFLON TAPE 010405-02-000.
 5. ADD PIPE WRAP (LADDER SCRAP 110157-02-000) INSULATION.
 6. LABEL HOT AND COLD SUPPLY TUBES AND TAPE FITTING TO TUBE BEFORE CABINET SET TO PREVENT MOVEMENT.
 7. ALL CRIMP FITTINGS TO 5/8" FLEX TUBING REQUIRE 5/8" CLAMP 140171-04-000.
 8. ALL CRIMP FITTINGS TO 1/2" PEX TUBING REQUIRE 1/2" CLAMP 140171-03-000.
 9. ALL CRIMP FITTINGS TO 3/4" PEX TUBING REQUIRE 3/4" CLAMP 140171-05-000.
 10. FASTEN PLATFORM TO FLOOR AFTER SIDEWALL IS SET AND HEATER IS ATTACHED TO WALL.

WINNEBAGO INDUSTRIES, INC. COPYRIGHT 2014

DFTR	ORIG. DATE
CHKR	ALL DIMENSIONS ARE IN MILLIMETERS
P.E.	
M.E.	FIRST USED
DSNR	14 E31KE

UNSPECIFIED TOLERANCES ARE:
 WHOLE DIM (X) : 3
 ONE-PLACE (X.X) :
 TWO-PLACE (X.XX) :
 ANGLE :

THIRD ANGLE PROJECTION

DO NOT SCALE DRAWING REFER TO ES0018 FOR FASTENER TIGHTENING GUIDELINES

TITLE: **WATER SYSTEM INSTL**

SHEET 1 OF 3 PART NO **183850** REV

REF: 1 19-May-2015

FOR WATER CALLOUTS SEE DWG NO 116230-01-000

*183850 *A

PANEL-SHOWER
167738-02-CHT
NUT-SPEED-U
040921-05-000 (4)

FAUCET-GALLEY
191983-01-CHT

FAUCET-LAV
186417-01-CHT

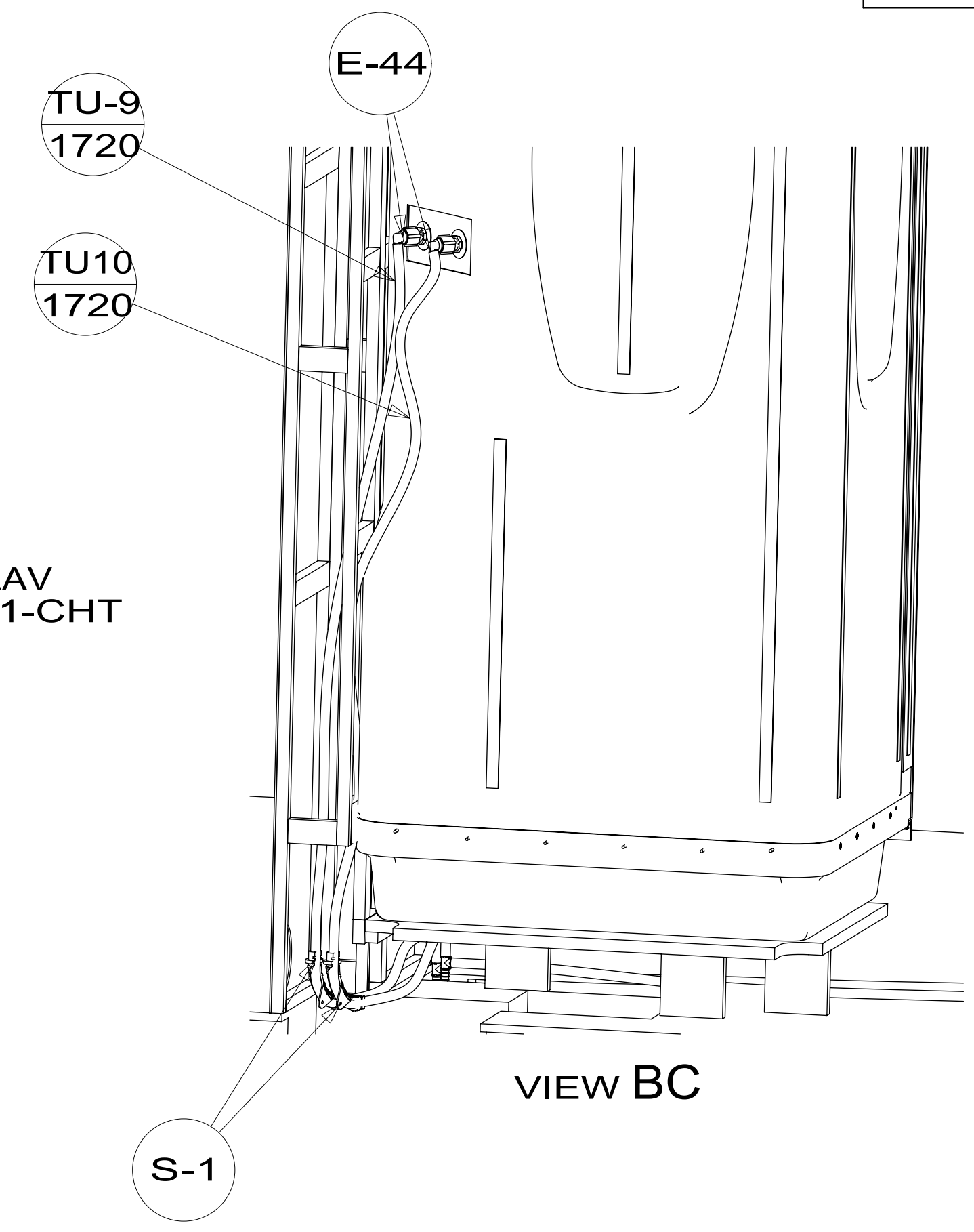
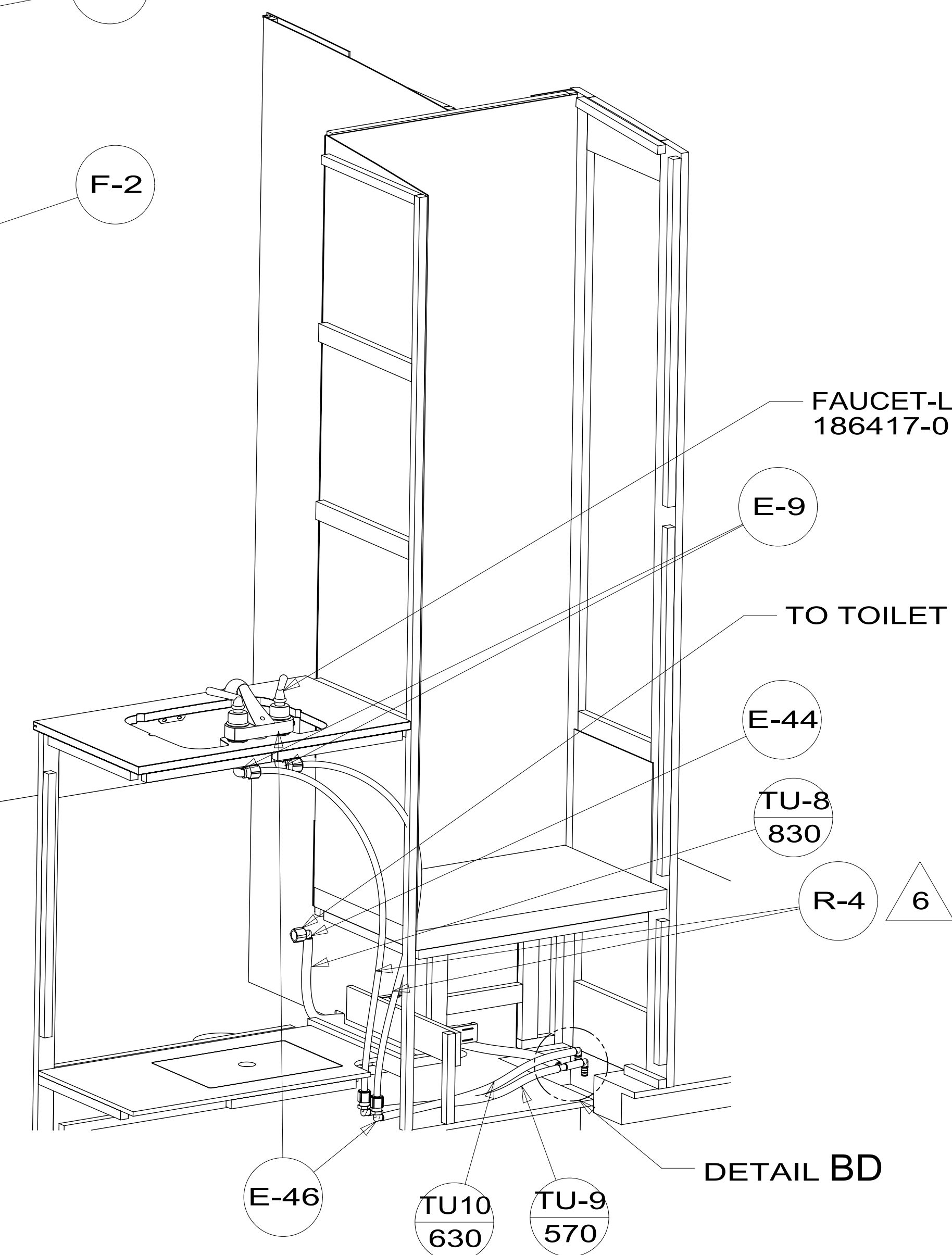
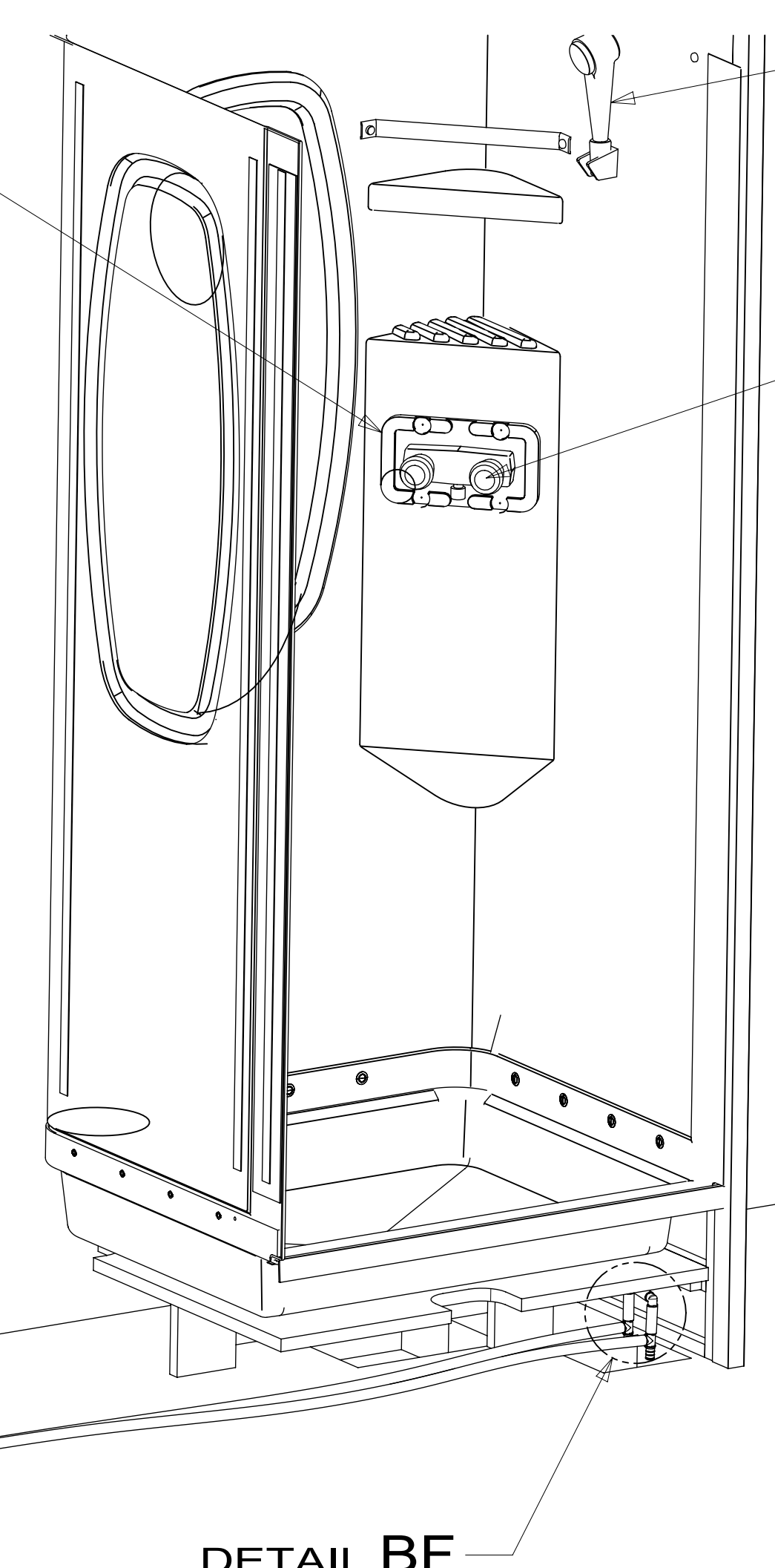
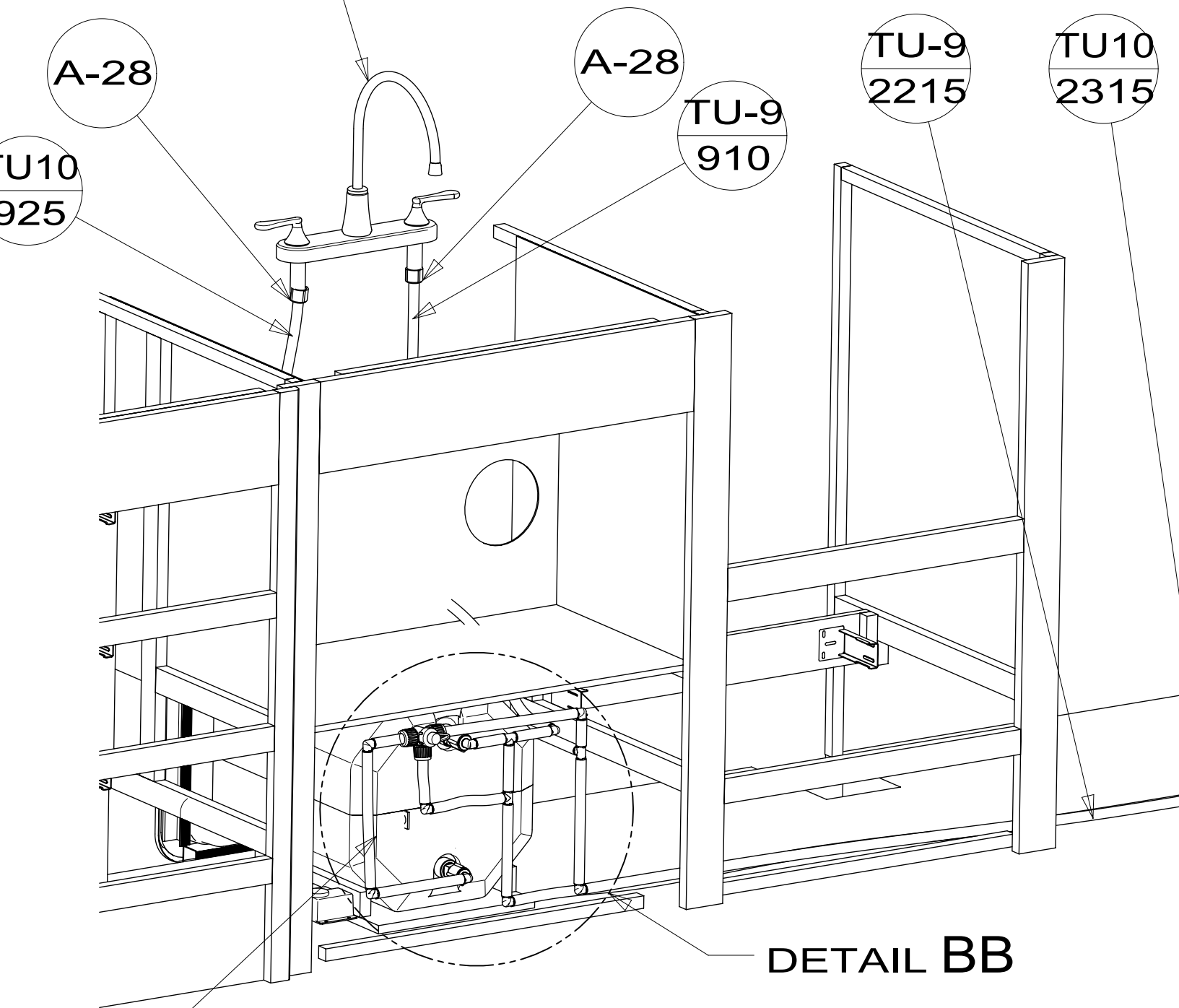

DETAIL BB

DETAIL BF

DETAIL BD

VIEW BC

WATER HEATER
184099-01-000
DOOR-WATER HEATER
184099-02-CHT
AL EXTR
002726-51-017 (4)
SCREW
000G39-10-12U (11)
SEALANT
069640-14-000
PLATFORM ASM-WATER
184166-01-000
SCREW
000G67-10-16U (2)

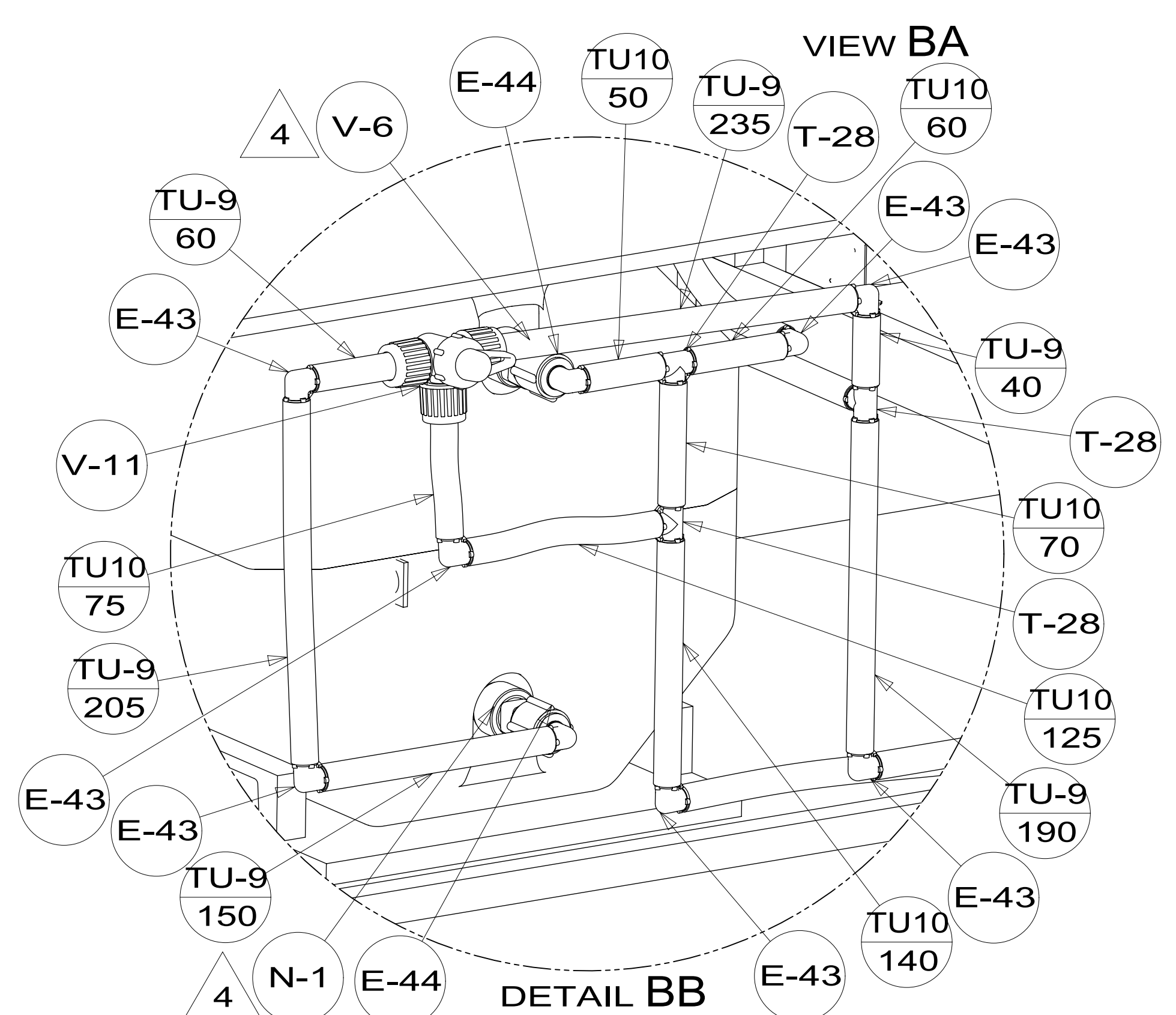

DETAIL BB

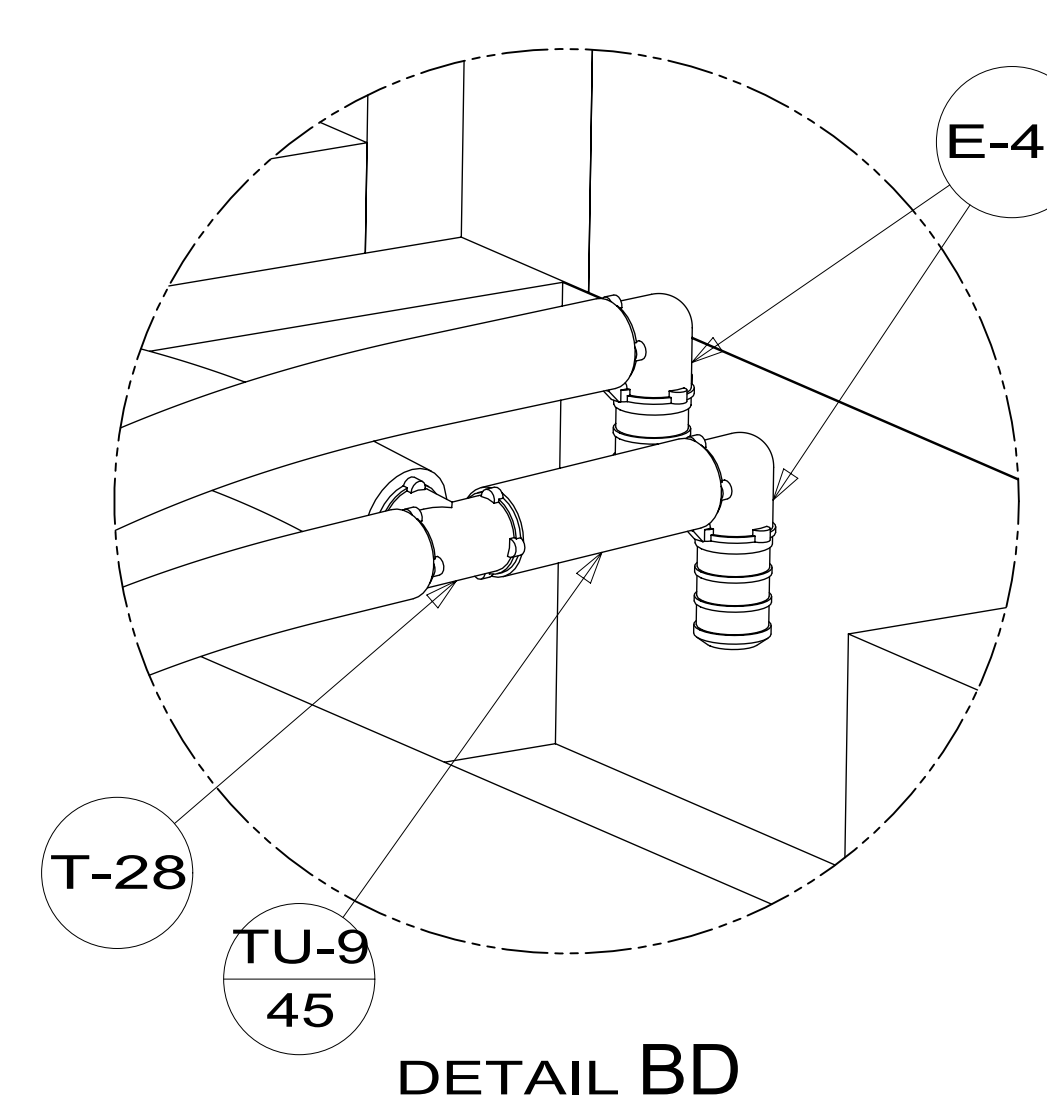

DETAIL BD

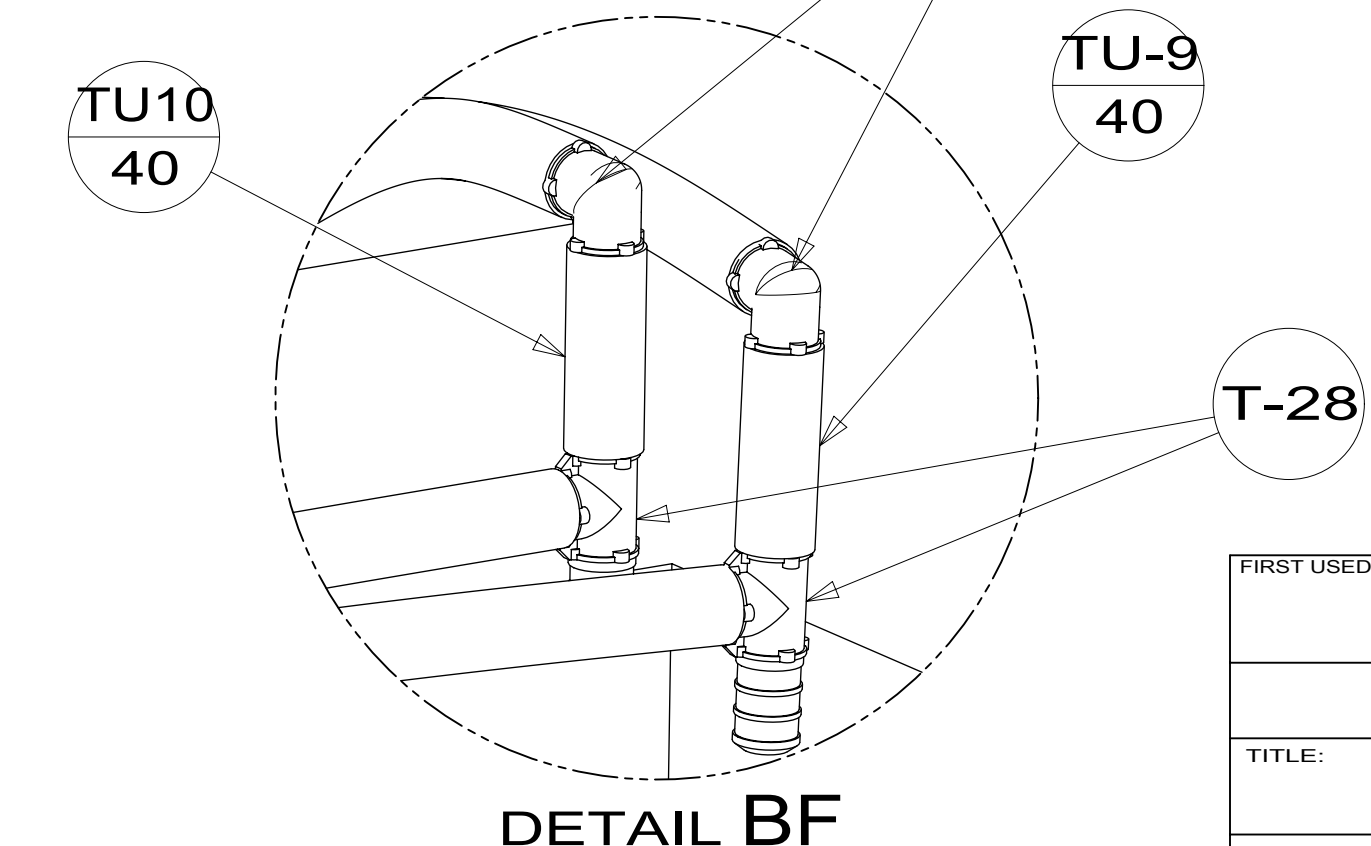

DETAIL BF

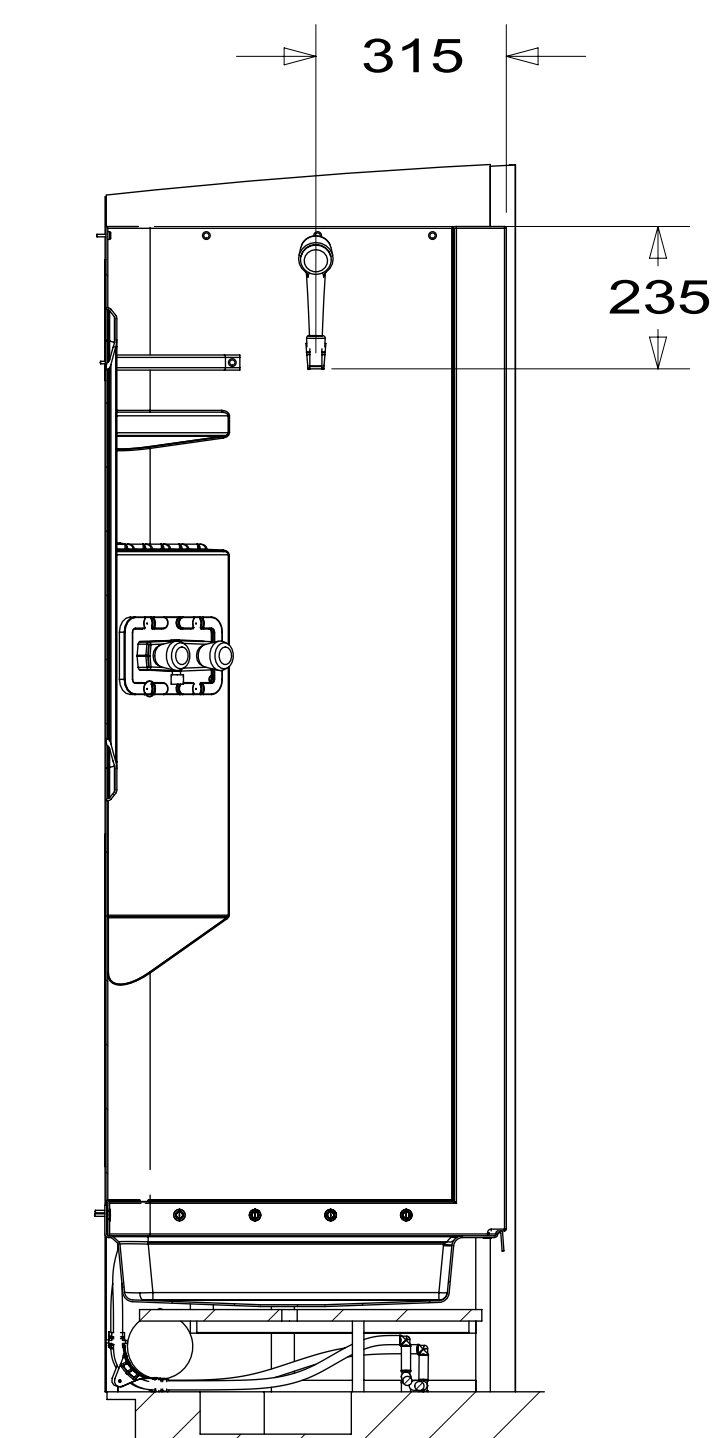

SECTION BE-BE

FIRST USED	14 E31KE	
TITLE:	DO NOT SCALE DRAWING	
SHEET	2	PART NO 183850
		REV
19-May-2015		

183850

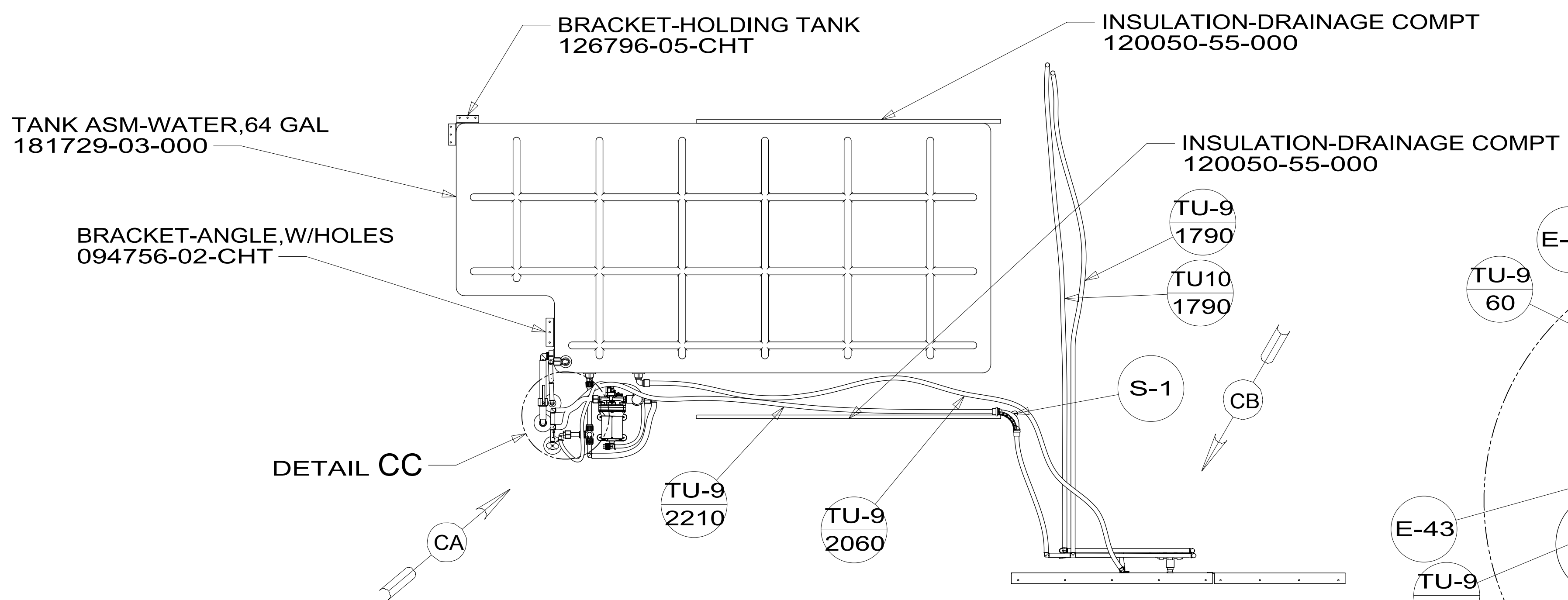

TOP VIEW SHOWING COMPTS UNDER FLOOR

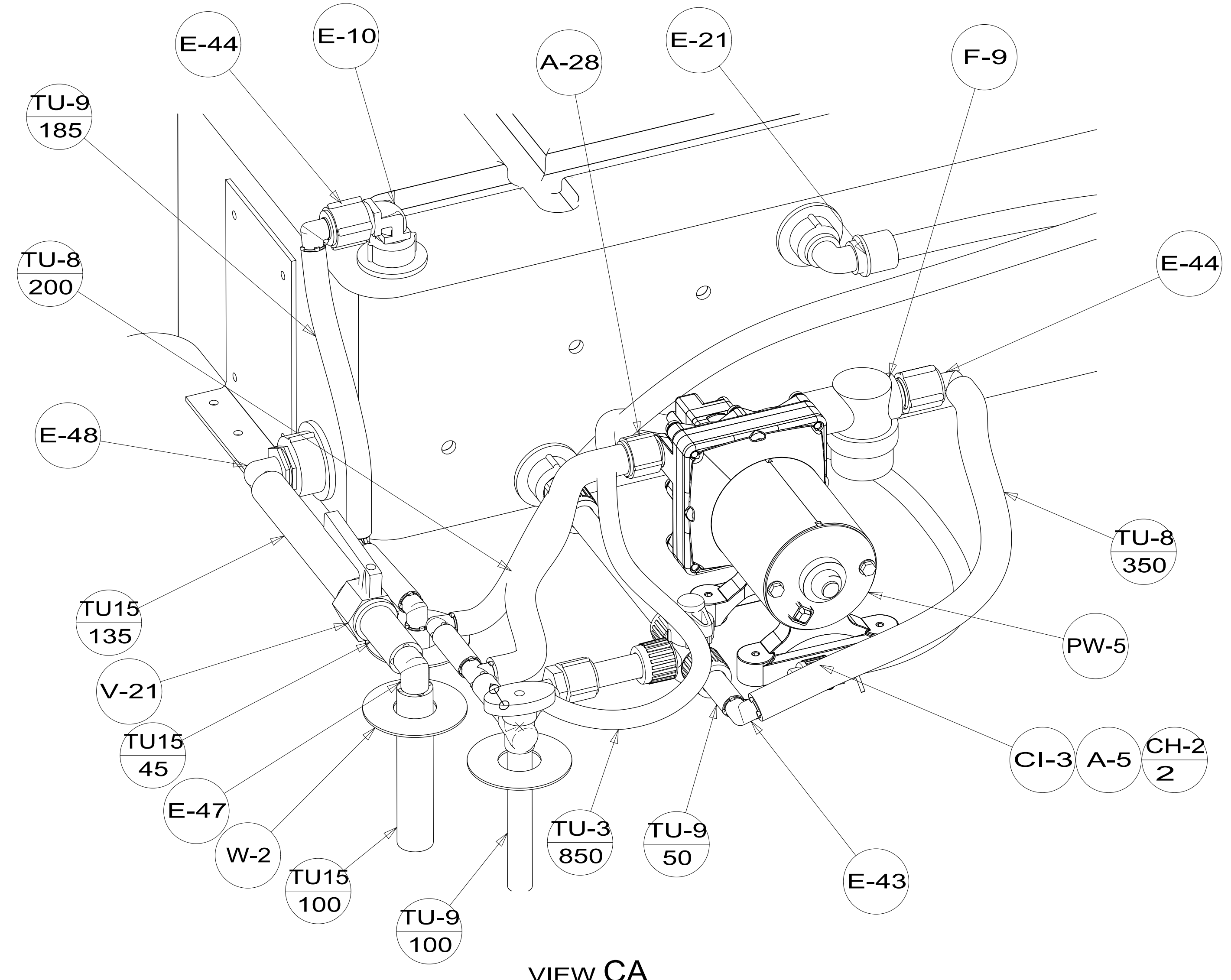
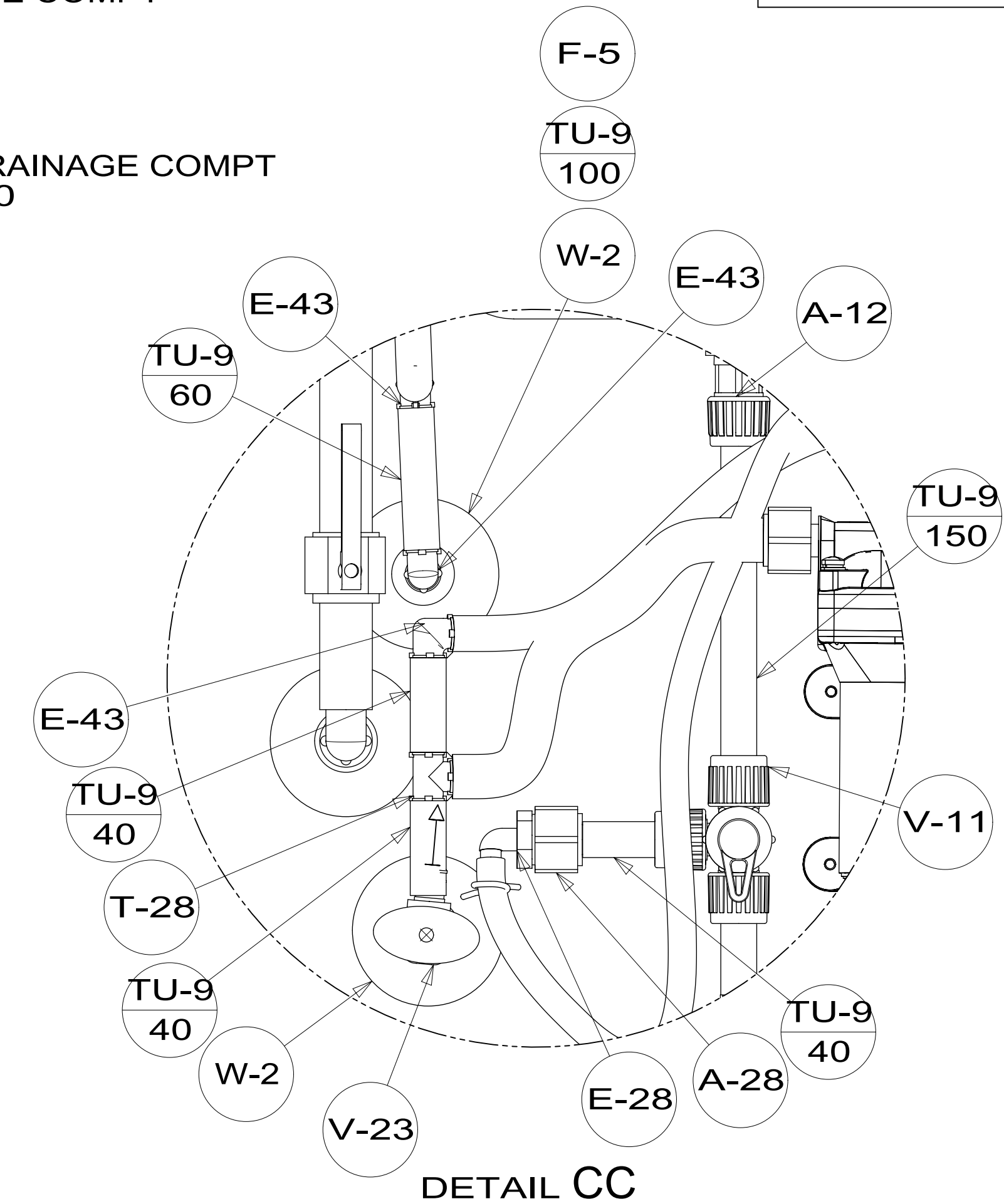

PANEL-SERVICE CENTER
154824-09-CHT

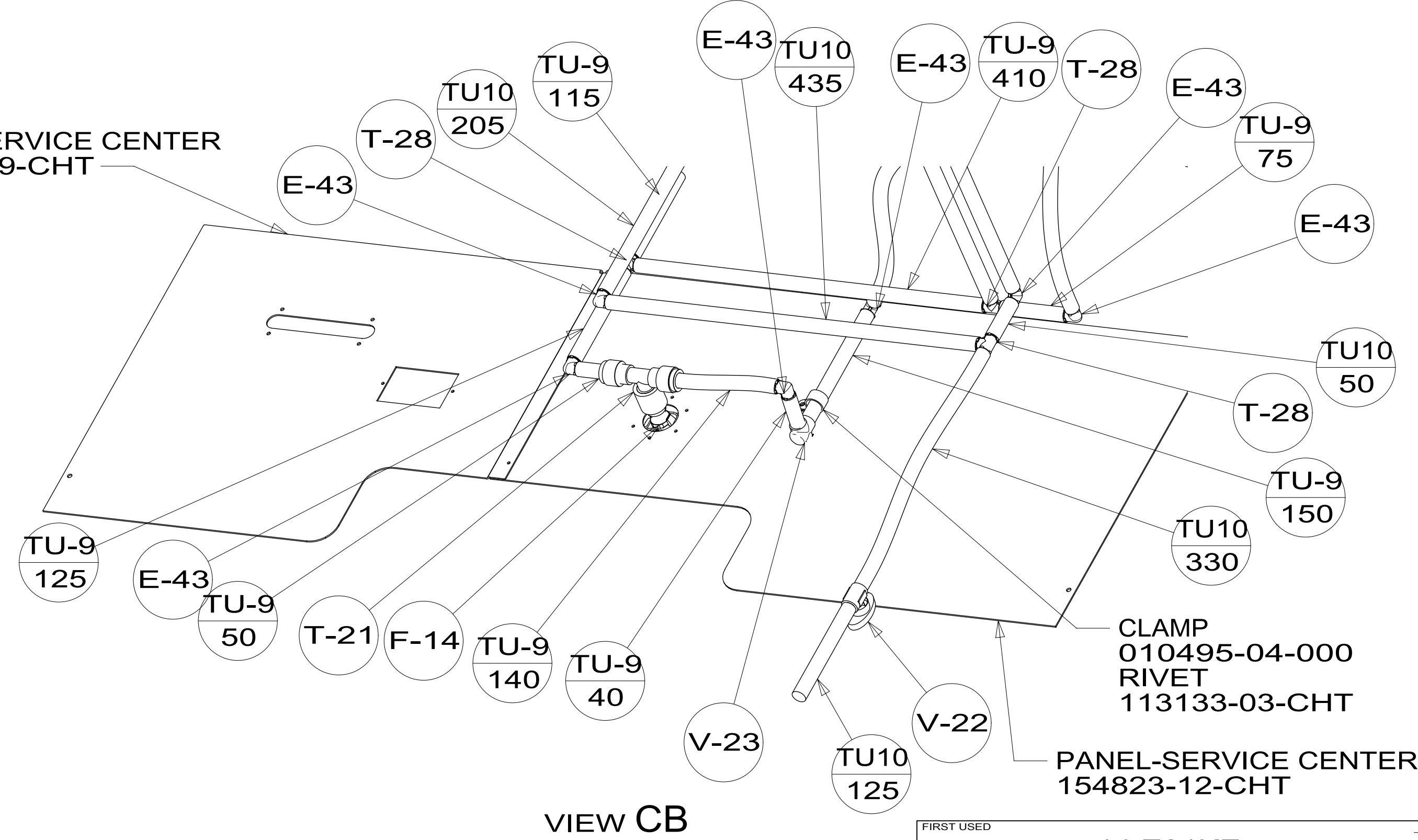

FIRST USED	14 E31KE	
TITLE:	DO NOT SCALE DRAWING	
SHEET	3	PART NO 183850 REV
		19-May-2015

183850