



**DANGER**

**Danger of electrical shock, burns or death.** Always remove all power sources before attempting any repair, service or diagnostic work. Power can be present from shore power, generator, inverter or battery. All power sources must be disabled and secured before performing any service.



**CAUTION**

If you lack the skills, tools or equipment to perform diagnostic or repair work leave such work to an authorized Winnebago Industries dealer or other qualified shop.





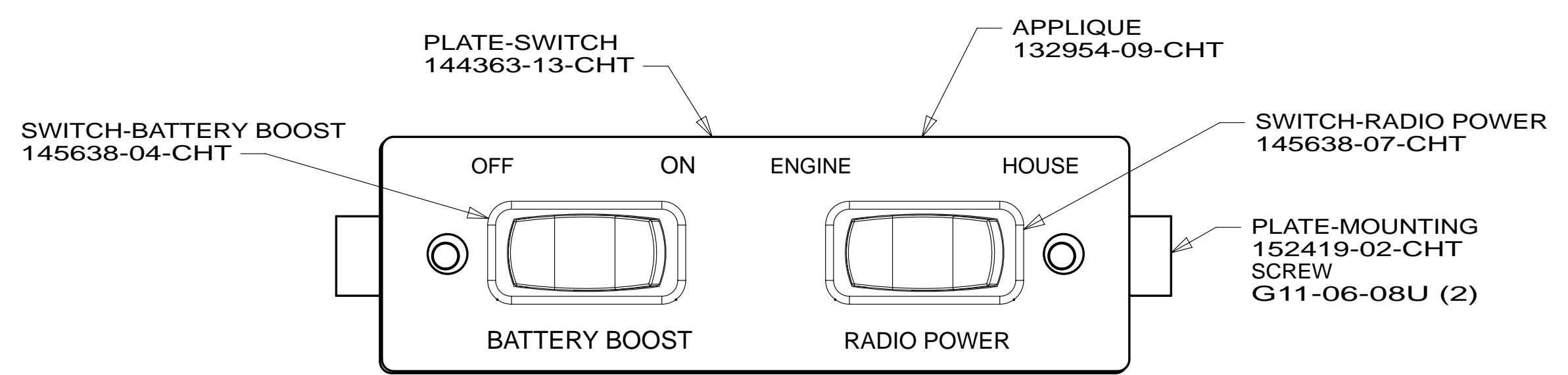

DETAIL CA

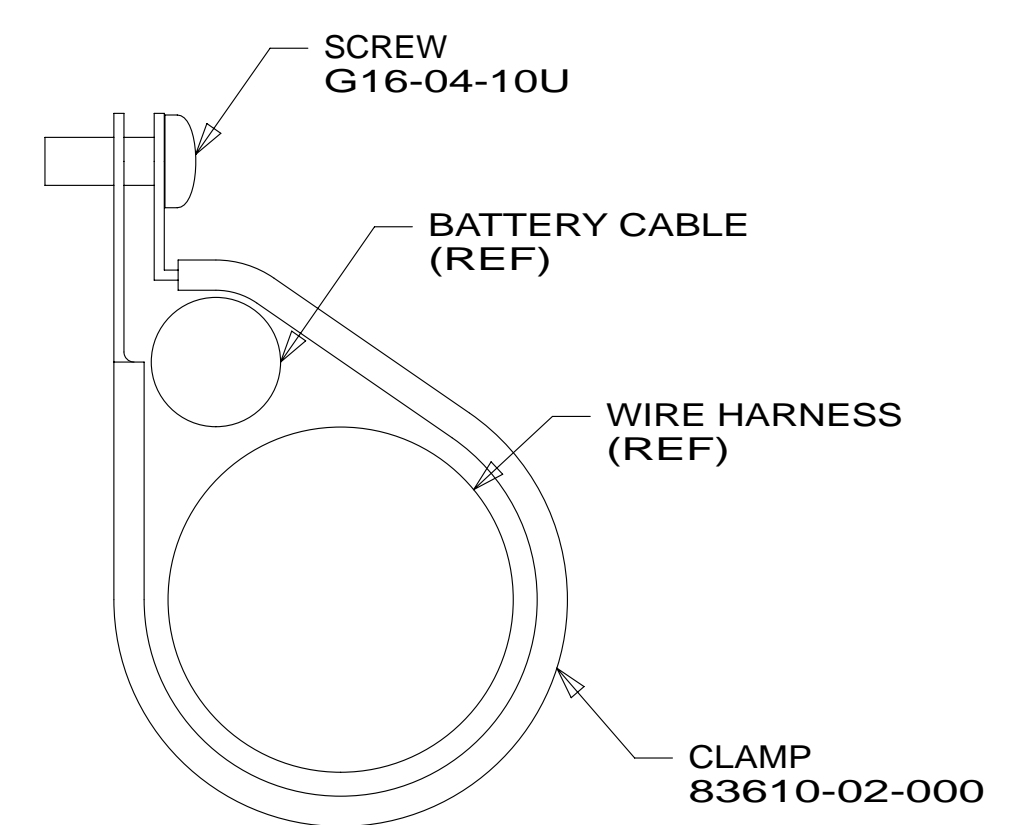

DETAIL CE (6 PLACES)

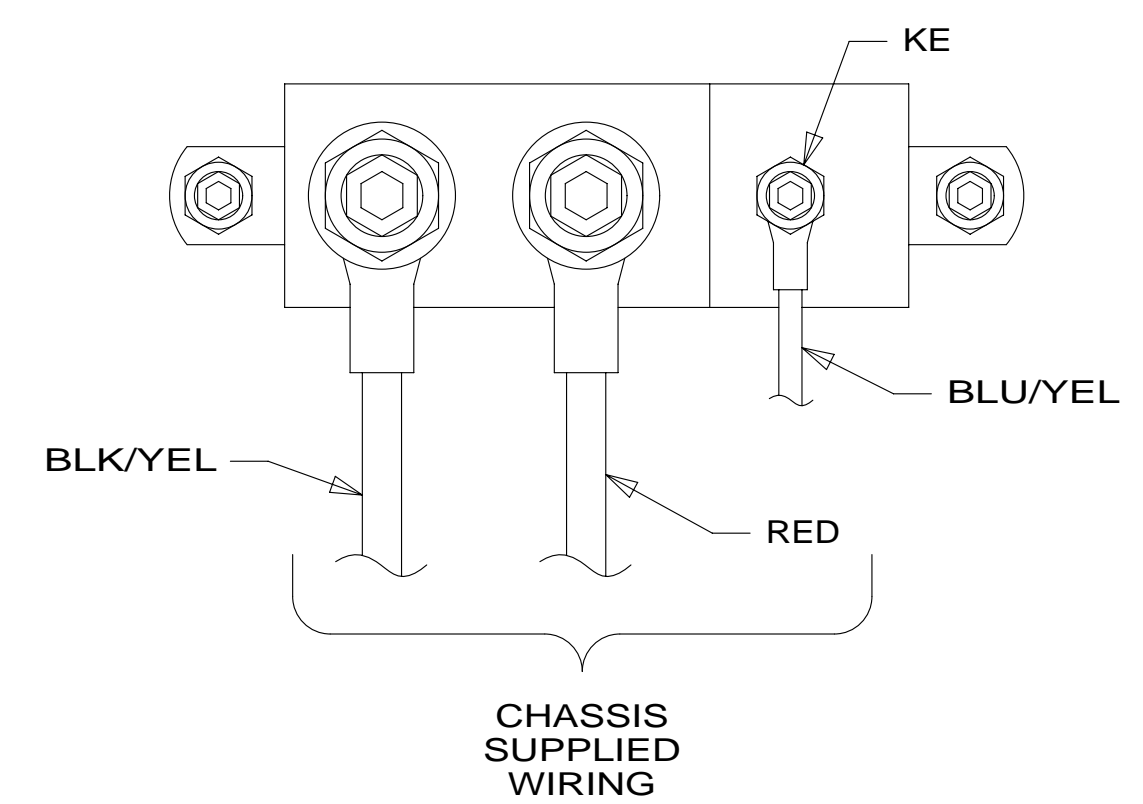

DETAIL CC 3

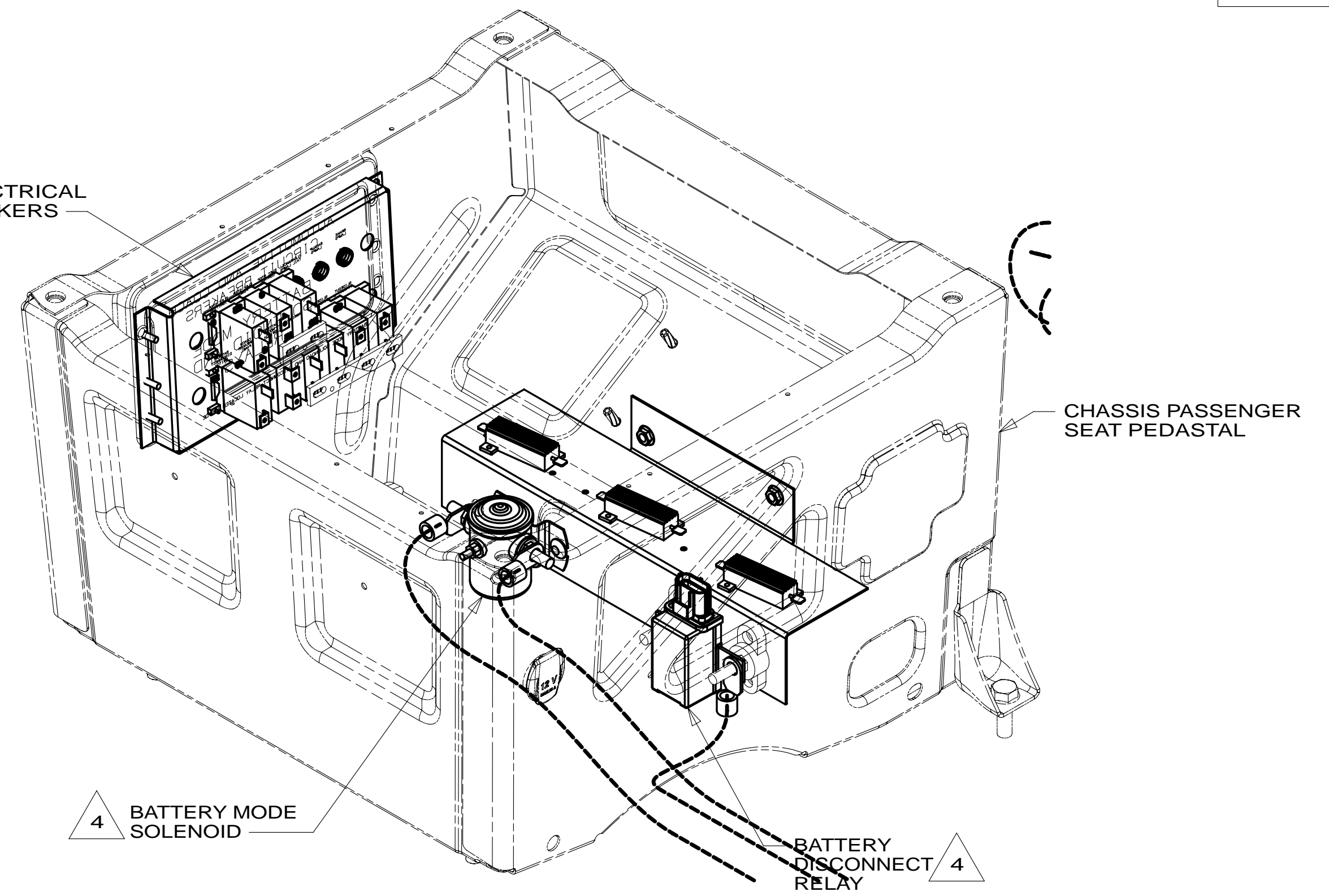

DETAIL CD

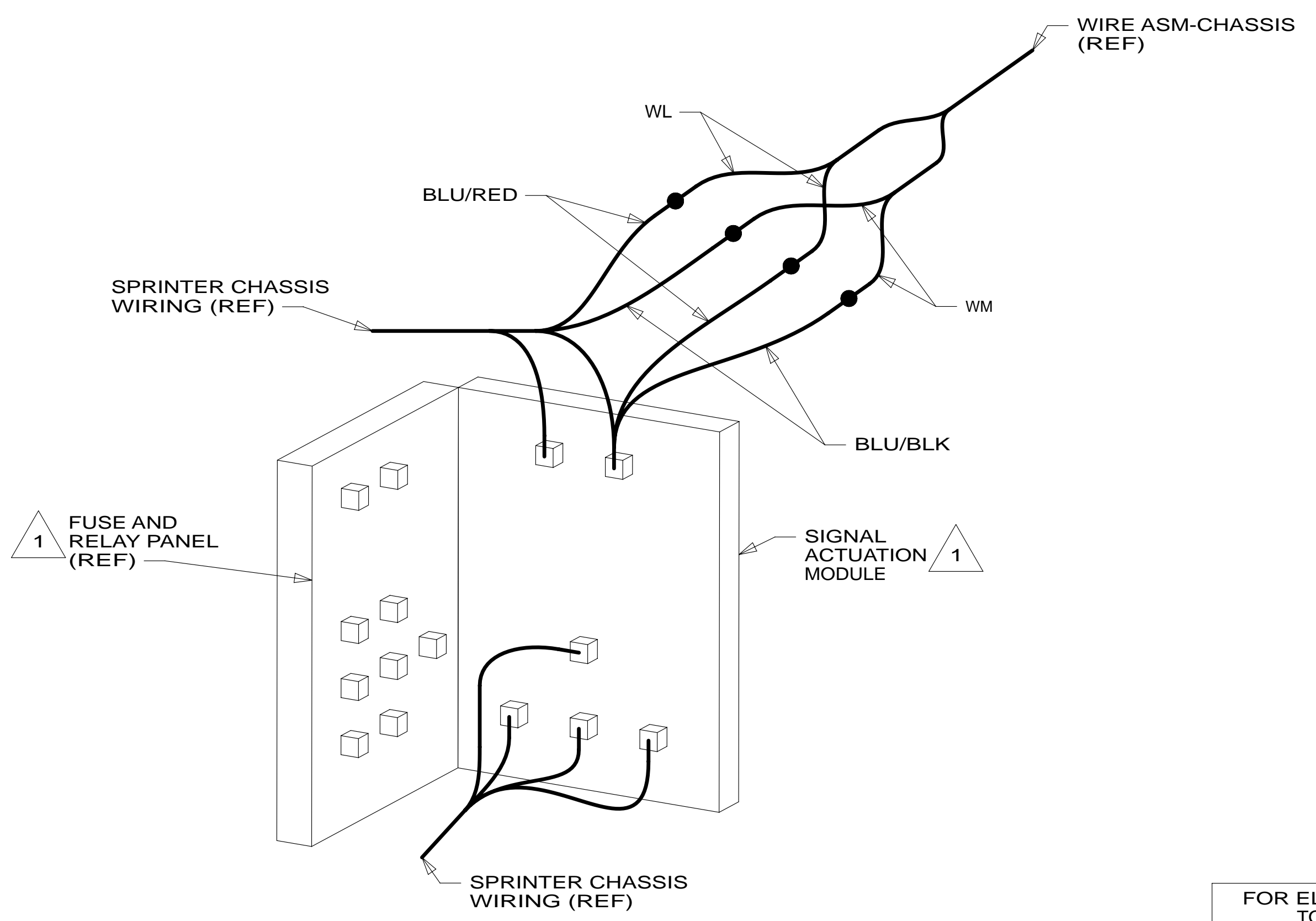

VIEW CB-CB

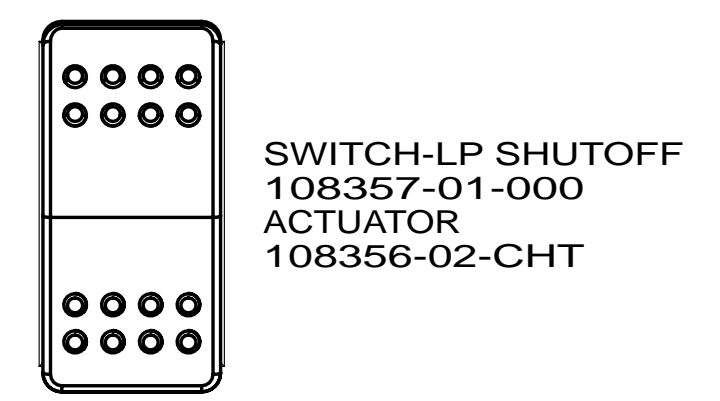

DETAIL CF

- NOTES:
- 4 SEE CHASSIS ELECTRICAL BOX ASM FOR ADDITIONAL INFORMATION.
  - 3 CONNECTION POINT IS LOCATED UNDER DRIVERS SEAT.
  - 2. SECURE CONDUIT 41953, TAB AS REQUIRED, OVER ALL WIRES IN CONTACT WITH SHARP EDGES.
  - 1 LOCATED IN DRIVERS SIDE KICKER PANEL.

FOR ELECTRICAL TORQUE SPECIFICATIONS SEE DWG NO. 128783-01-000

FOR ELECTRICAL CALLOUTS SEE DWG NO. 121339-01-000

1MD MERCEDES-11,030# GVWR,DIESEL  
 265 CODES/STANDARDS-CSA/CMVSS  
 1B1 CODES/STANDARDS USA

1B1	265	1MD
FIRST USED		
<b>14 524G</b>		
DO NOT SCALE DRAWING		
TITLE: <b>WIRING INSTL-CHASSIS</b>		
SHEET 3	PART NO <b>186926</b>	REV

\* 186926