



DANGER

Danger of electrical shock, burns or death. Always remove all power sources before attempting any repair, service or diagnostic work. Power can be present from shore power, generator, inverter or battery. All power sources must be disabled and secured before performing any service.



CAUTION

If you lack the skills, tools or equipment to perform diagnostic or repair work leave such work to an authorized Winnebago Industries dealer or other qualified shop.

DRAWING NO.	FEATURE
186746-12	1B1 78J
186746-16	265 78J

RELEASE	REV/DATE	DWG NO	186746
REV ZONE	REVISION RECORD	DATE	DFT-ORIG

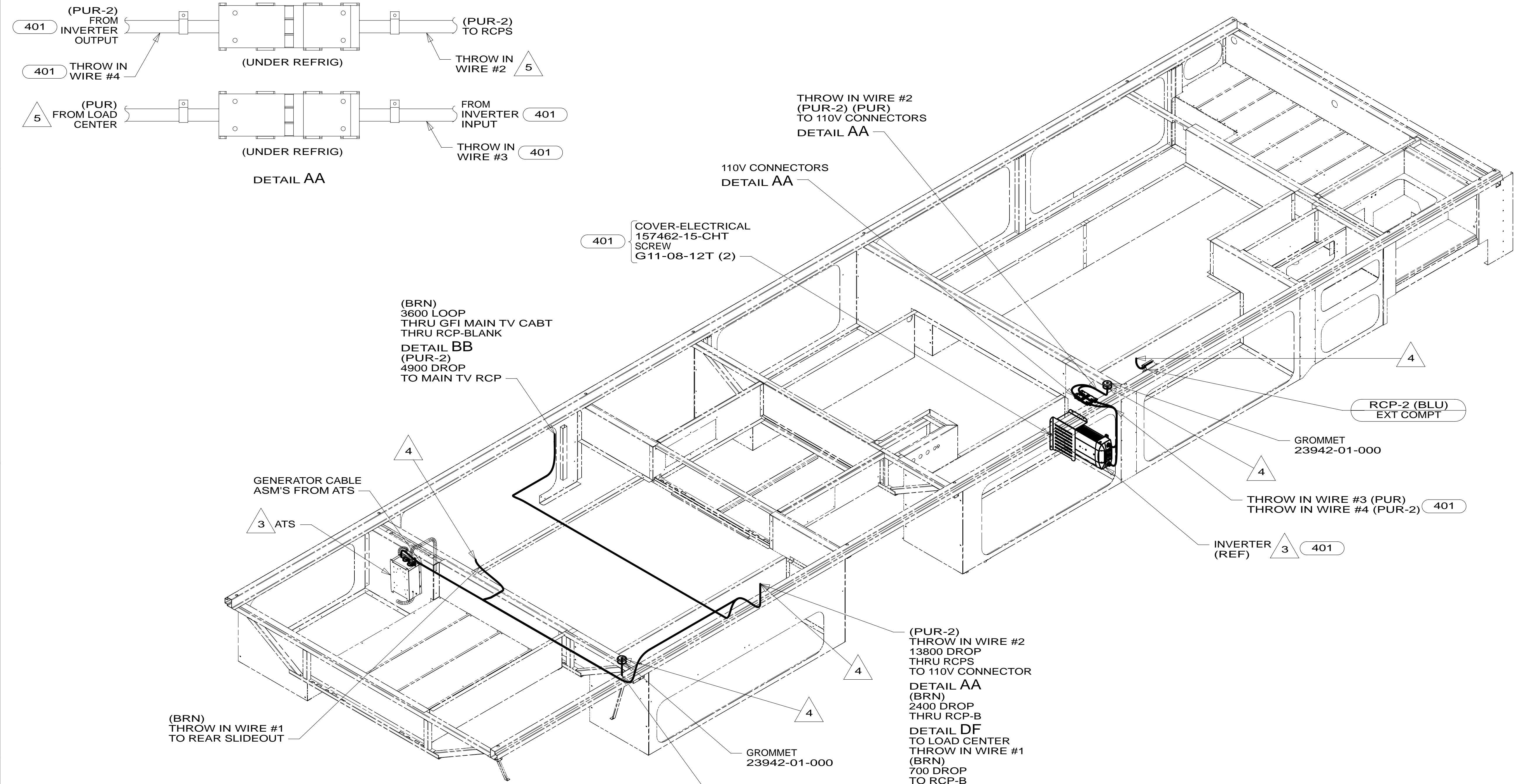

- 5 WITHOUT INVERTER THROW IN #2 (PUR-2) CONNECTS TO (PUR) FROM LOAD CENTER.
- 4 WIRE ROUTED THROUGH FLOOR IN THIS AREA.
- 3 SEE LOAD CENTER/ATS ASM FOR ADDITIONAL INFORMATION.
2. WIRES ROUTED UNDER FLOOR.
1. ALL WIRES TO BE SECURED WITH CLAMP 10495 OR 10497 OR WIRE TIE 8343 OR 108046 EVERY 600MM, USE SCREW G67-XX-XXX OR G56-XX-XXX AS APPROPRIATE FOR INSTALLATION.

- 401 INVERTER-DC/AC, 1000 WATT
- 78J ELECTRICAL SYSTEM-50 AMP
- 265 CODES/STANDARDS-CSA/CMVSS
- 1B1 CODES/STANDARDS USA

1B1 265

WINNEBAGO COPYRIGHT 2013 WINNEBAGO INDUSTRIES, INC.

DFT-ORIG	ORIG. DATE
CHKR	ALL DIMENSIONS ARE IN MILLIMETERS
P.E.	FIRST USED
M.E.	14 D36V
DSNR	

UNSPECIFIED TOLERANCES ARE:

WHOLE DIM (X)	: 3
ONE-PLACE (X.X)	: 1.5
TWO-PLACE (X.XX)	: 0.50
ANGLE	: 1°

THIRD ANGLE PROJECTION

DO NOT SCALE DRAWING REFER TO ES0018 FOR FASTENER TIGHTENING GUIDELINES

TITLE: **WIRING INSTL-BODY,110V**

SHEET 1 OF 5 PART NO **186746** REV

REF: 1 03-May-2013

FOR ELECTRICAL TORQUE SPECIFICATIONS SEE DWG NO. 128783-01-000

FOR ELECTRICAL CALLOUTS SEE DWG NO. 121339-01-000

* 186746 * A

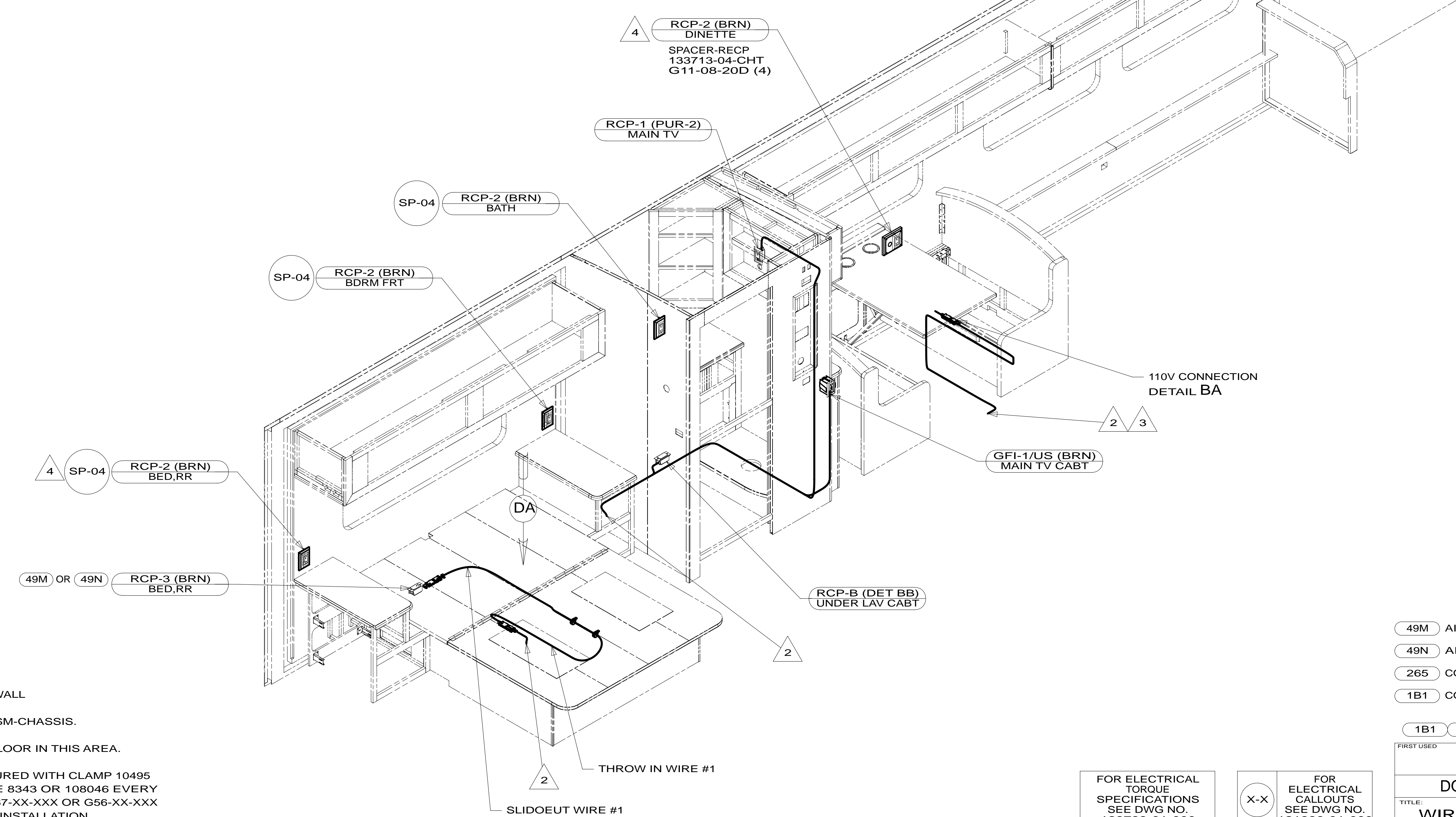
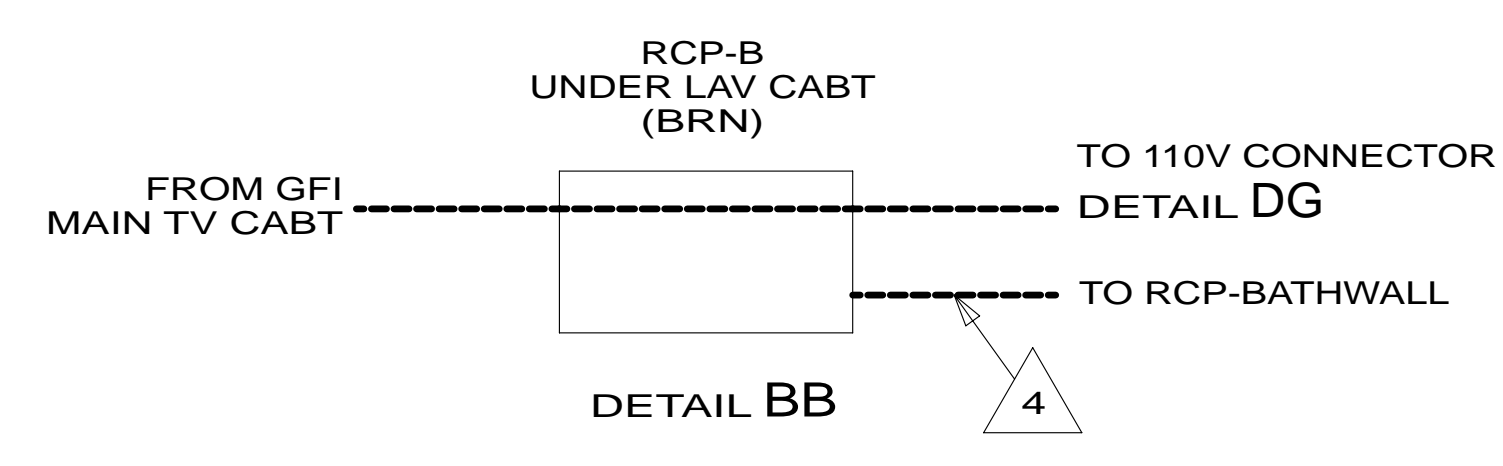
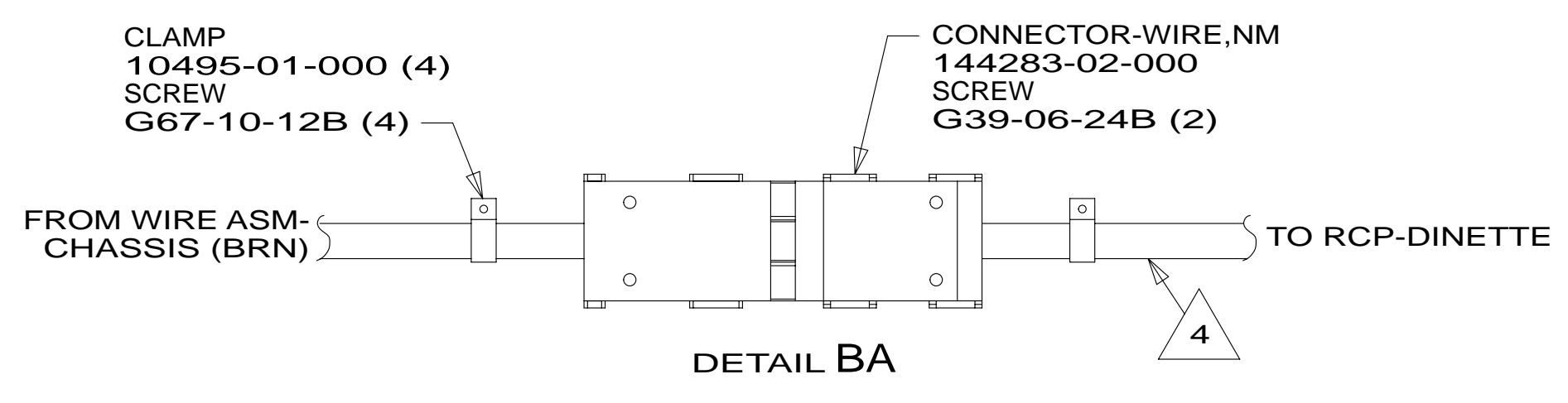

- 4 WIRE ROUTED IN SIDEWALL
- 3 WIRE PART OF WIRE ASM-CHASSIS.
- 2 WIRE ROUTES THRU FLOOR IN THIS AREA.

1. ALL WIRES TO BE SECURED WITH CLAMP 10495 OR 10497 OR WIRE TIE 8343 OR 108046 EVERY 600MM, USE SCREW G67-XX-XXX OR G56-XX-XXX AS APPROPRIATE FOR INSTALLATION.

- 49M AIR SLEEP SYSTEM-QUEEN SIZE
- 49N AIR SLEEP SYSTEM - KING SIZE
- 265 CODES/STANDARDS-CSA/CMVSS
- 1B1 CODES/STANDARDS USA

FIRST USED		14 D36V	
DO NOT SCALE DRAWING			
TITLE: WIRING INSTL-BODY, 110V			
SHEET 2	PART NO	186746	REV
		1	03-May-2013

FOR ELECTRICAL TORQUE SPECIFICATIONS SEE DWG NO. 128783-01-000

FOR ELECTRICAL CALLOUTS SEE DWG NO. 121339-01-000

* 186746 * A

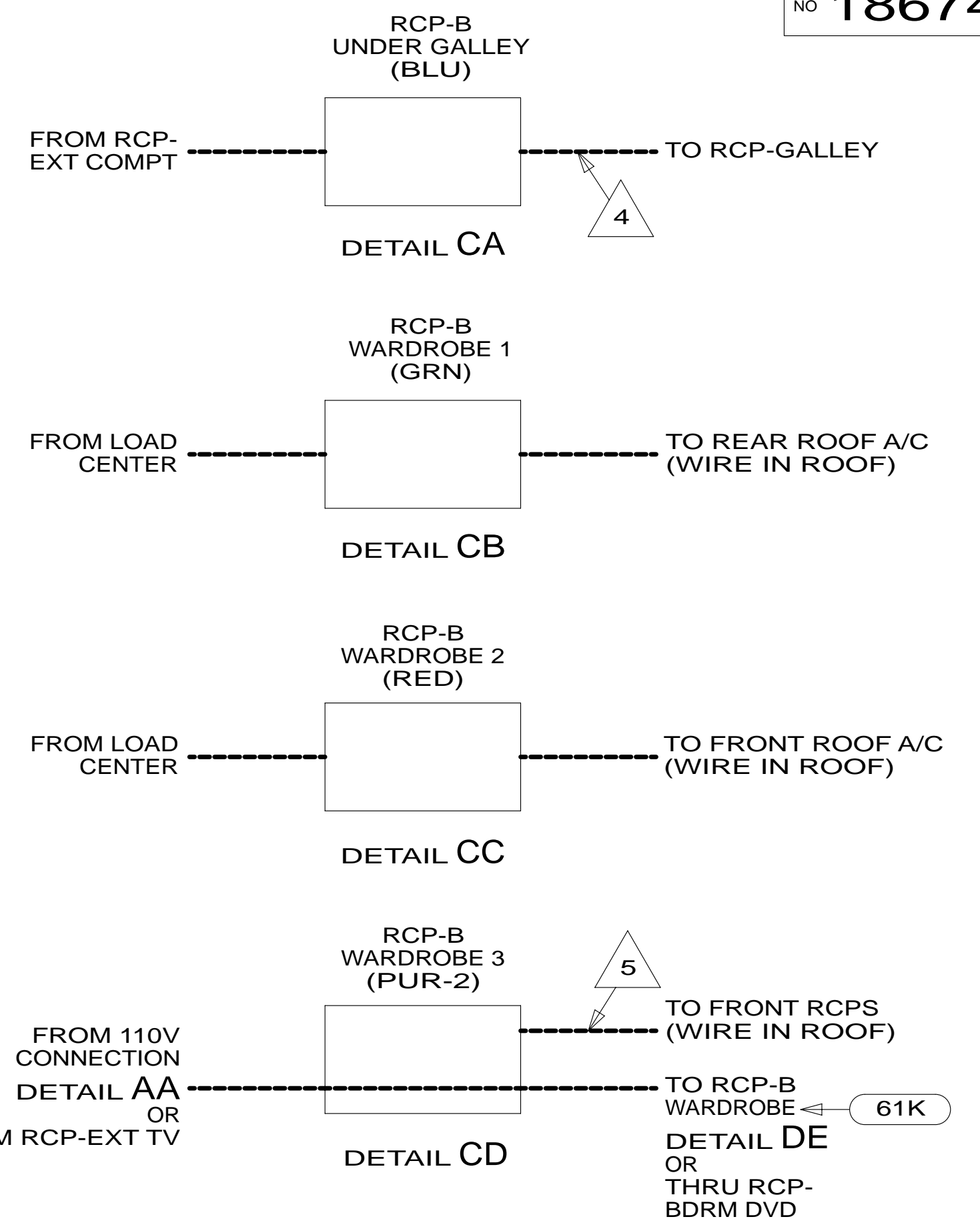
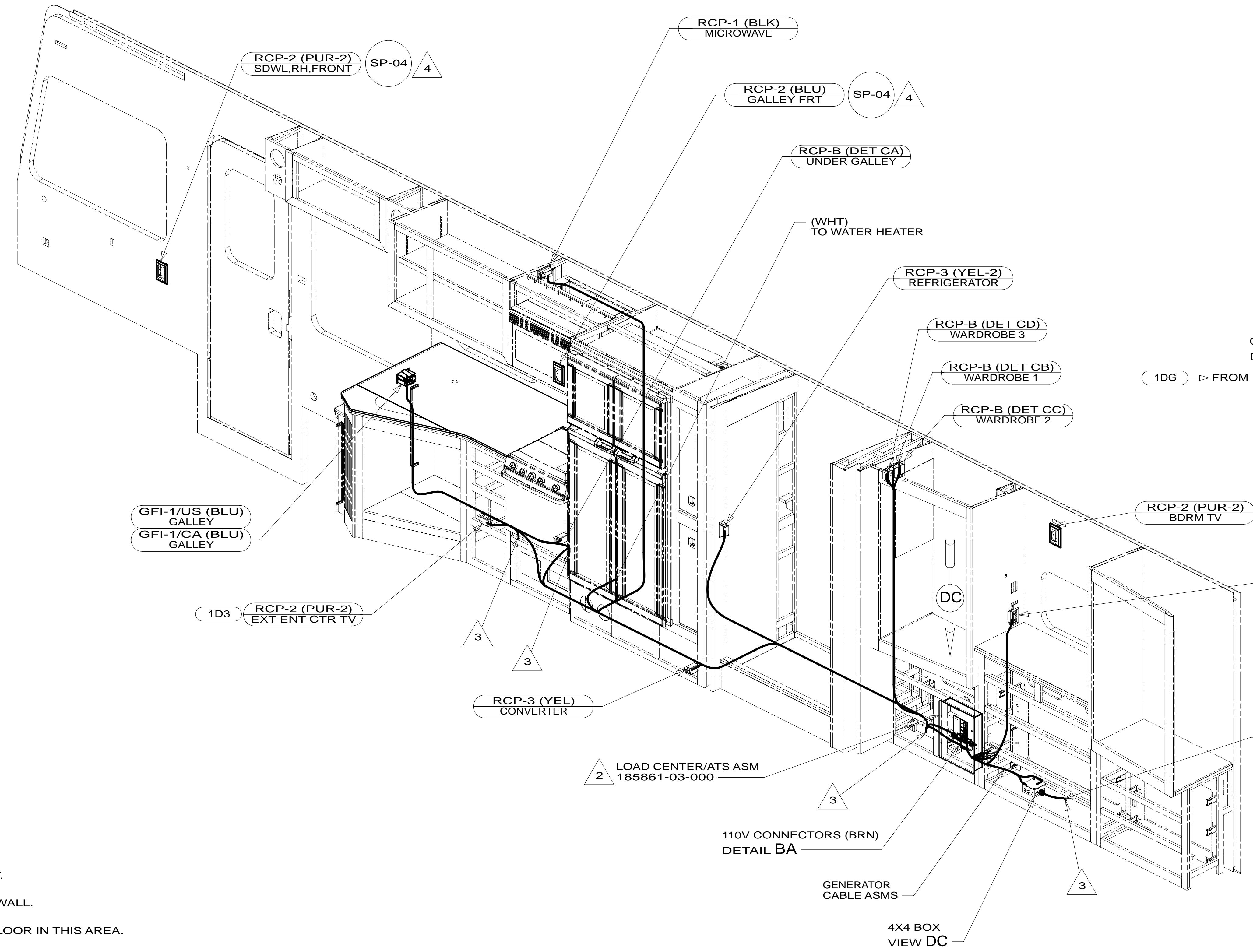

- 5 WIRE ROUTED IN ROOF.
- 4 WIRE ROUTED IN SIDEWALL.
- 3 WIRES ROUTE THRU FLOOR IN THIS AREA.
- 2 LOAD CENTER GROUND WIRES MUST BE ATTACHED DIRECTLY TO CHASSIS GROUND.

1. ALL WIRES TO BE SECURED WITH CLAMP 10495 OR 10497 OR WIRE TIE 8343 OR 108046 EVERY 600MM, USE SCREW G67-XX-XXX OR G56-XX-XXX AS APPROPRIATE FOR INSTALLATION.

NOTES:

- 1DG EXT ENTERTAIN CTR W/TV & CD
- 61K TV(REAR)-26" COLOR STEREO
- 265 CODES/STANDARDS-CSA/CMVSS
- 1B1 CODES/STANDARDS USA

FIRST USED	
14 D36V	
DO NOT SCALE DRAWING	
WIRING INSTL-BODY, 110V	
SHEET 3	PART NO 186746 REV

FOR ELECTRICAL TORQUE SPECIFICATIONS SEE DWG NO. 128783-01-000

FOR ELECTRICAL CALLOUTS SEE DWG NO. 121339-01-000

* 186746 * A

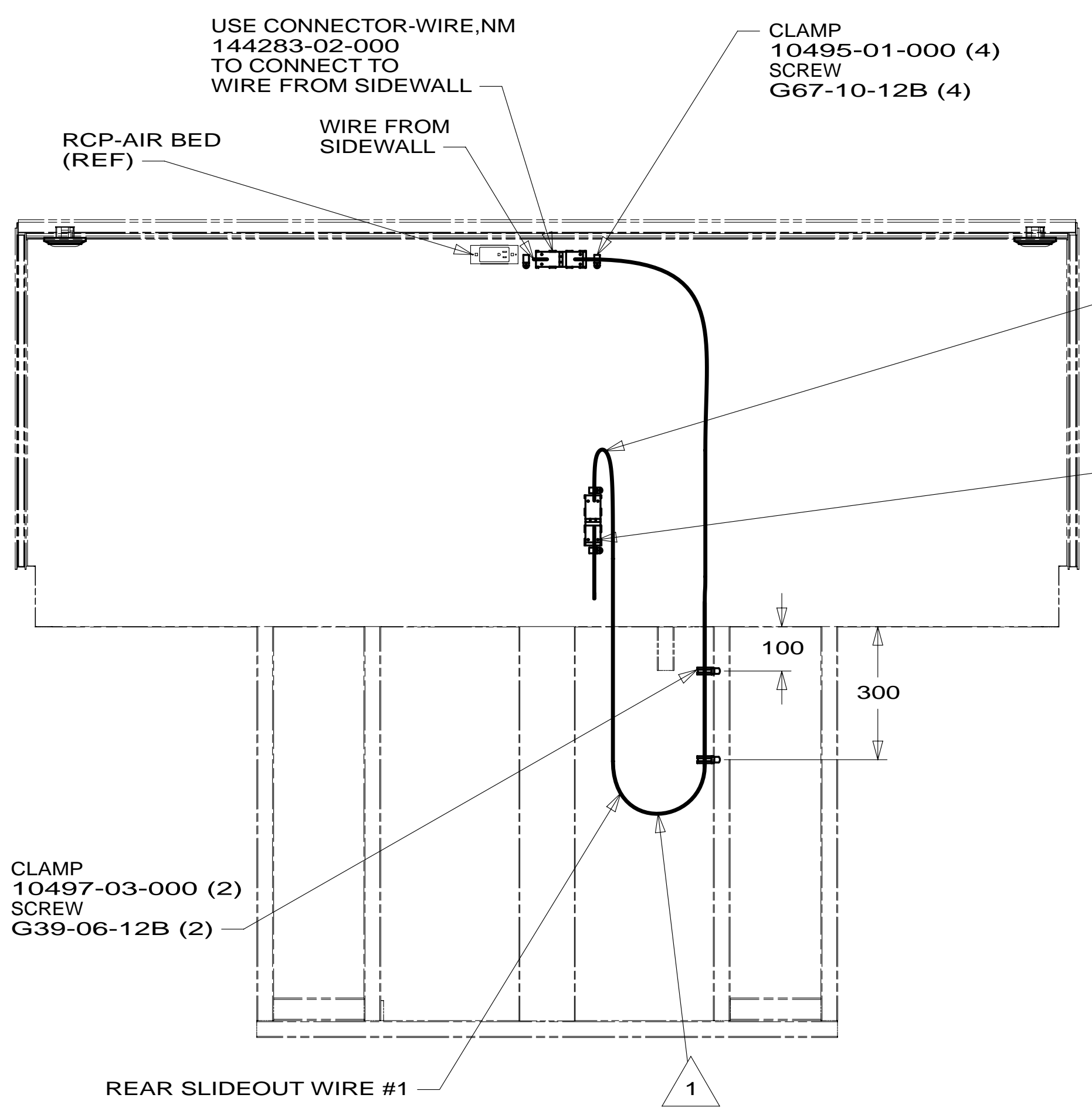

DETAIL DA

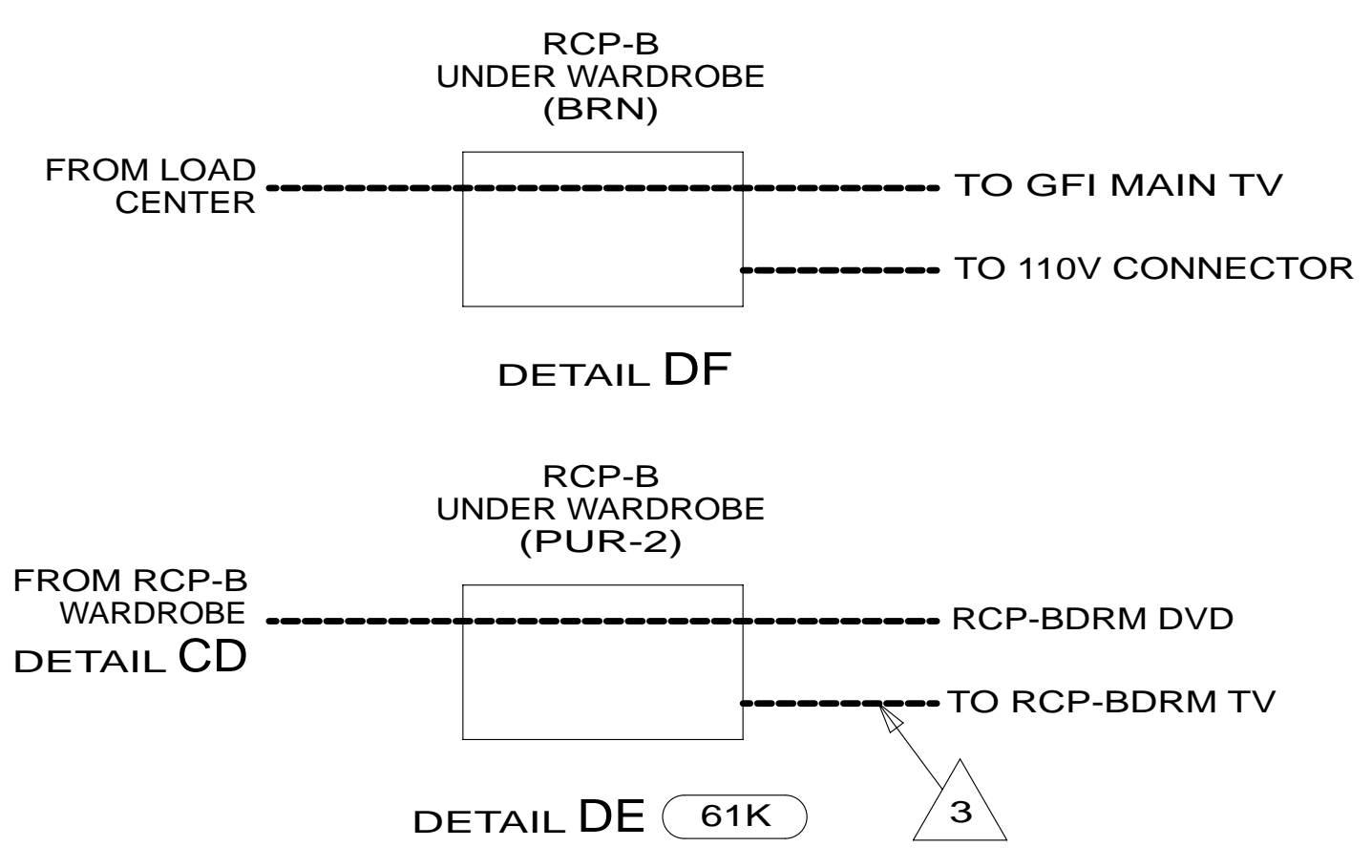

DETAIL DF

DETAIL DE 61K

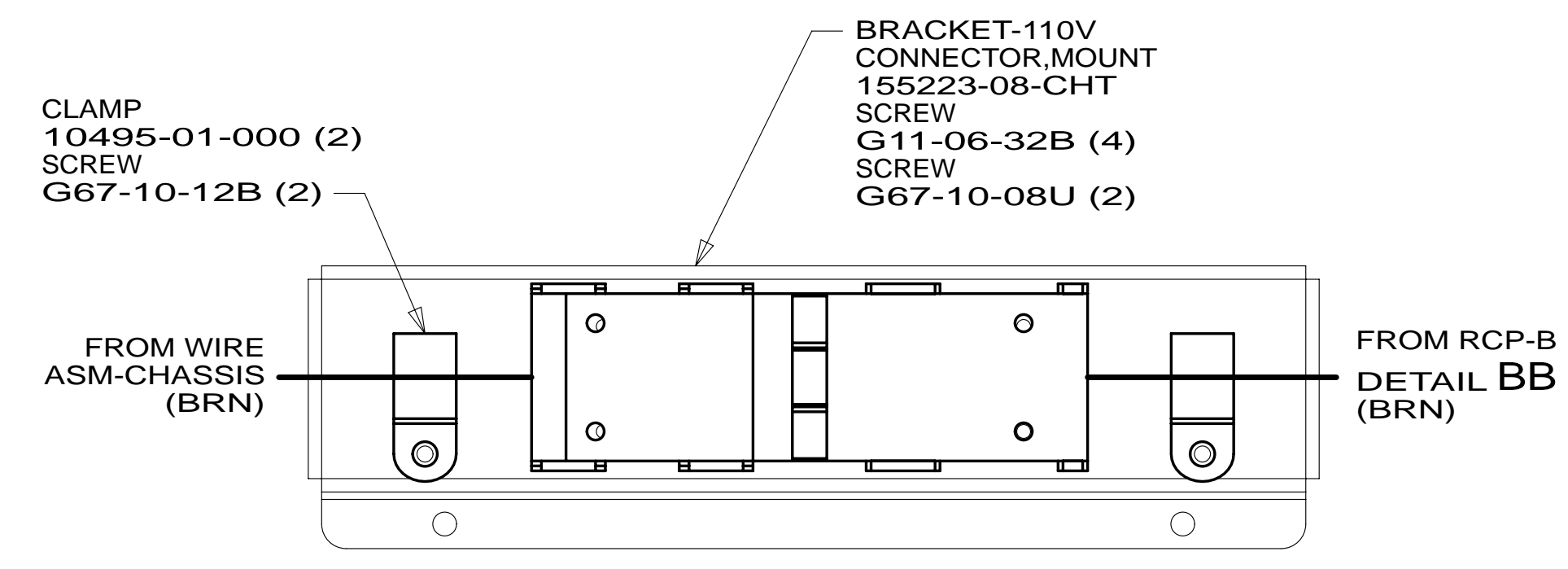

DETAIL DG

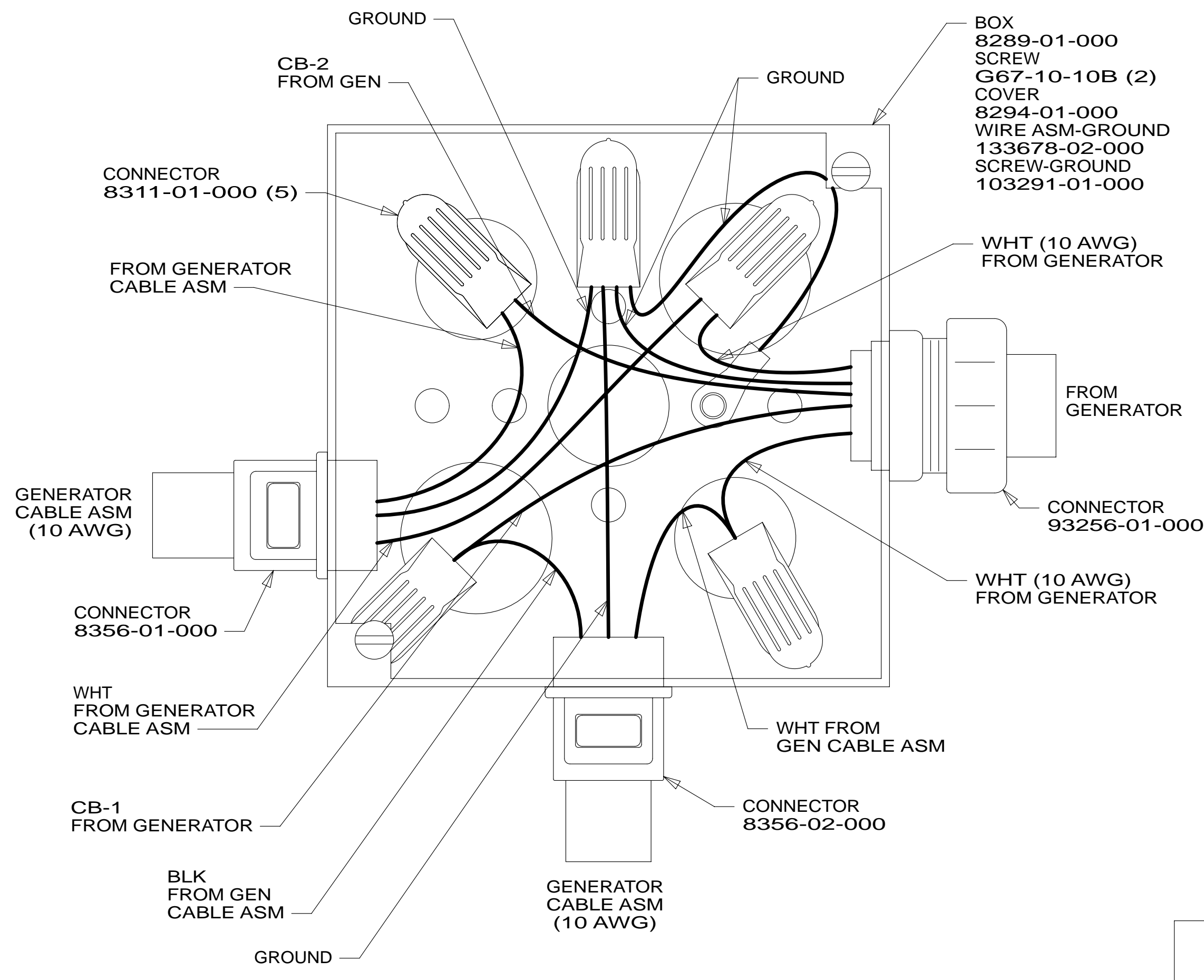

DETAIL DD 2

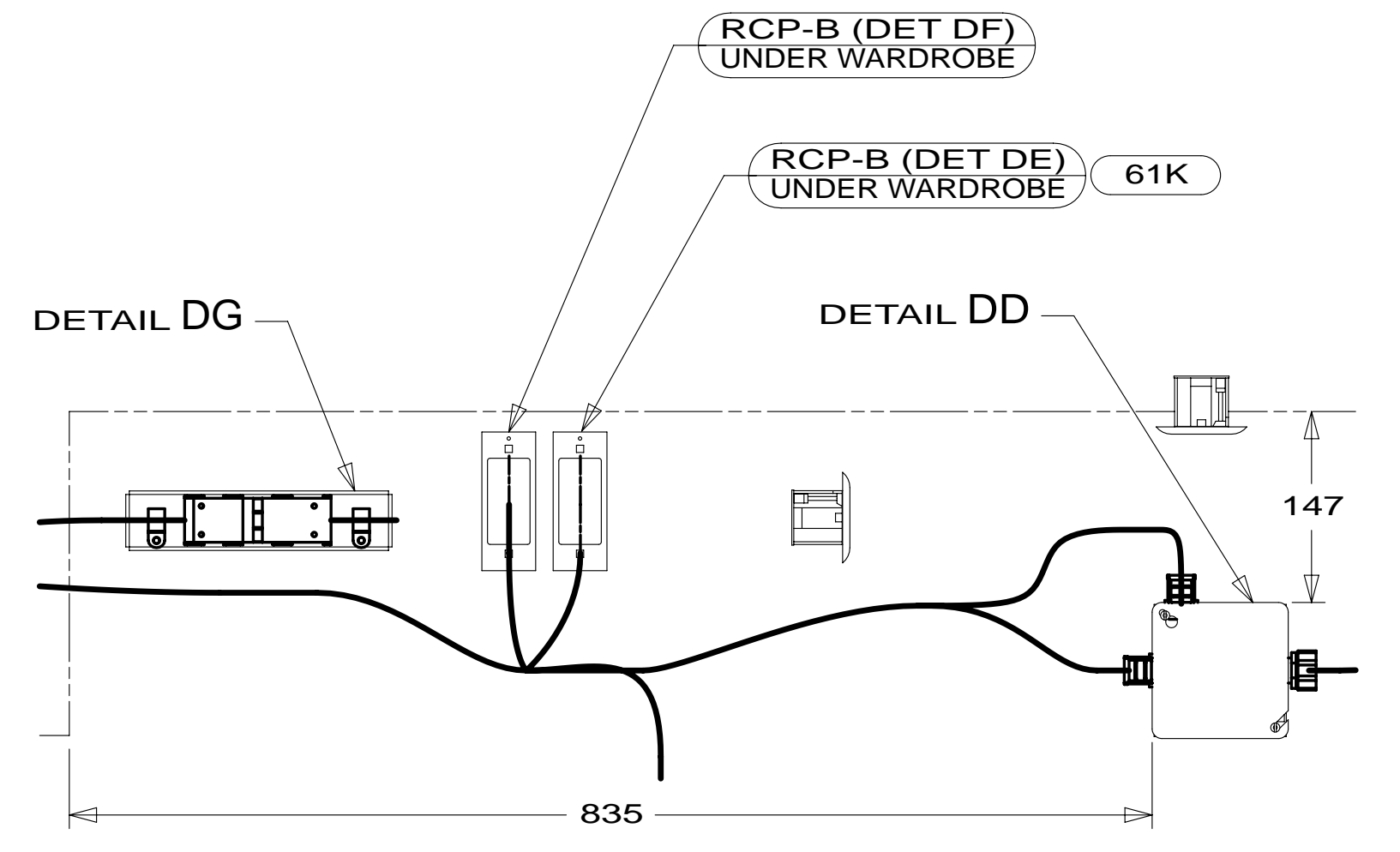

VIEW DC

- NOTES:
- 3 WIRE ROUTED IN SIDEWALL.
 - 2 SEE LOAD CENTER/ATS ASM FOR ADDITIONAL INFORMATION.
 - 1 MAKE LOOP AS SMALL AS POSSIBLE WHEN SLIDEOUT IS COMPLETELY RETRACTED.

- 61K TV(REAR)-26" COLOR STEREO
- 265 CODES/STANDARDS-CSA/CMVSS
- 1B1 CODES/STANDARDS USA

FIRST USED	
14 D36V	
DO NOT SCALE DRAWING	
TITLE: WIRING INSTL-BODY, 110V	
SHEET 4	PART NO 186746 REV
03-May-2013	

FOR ELECTRICAL TORQUE SPECIFICATIONS SEE DWG NO. 128783-01-000

FOR ELECTRICAL CALLOUTS SEE DWG NO. 121339-01-000

* 186746 * A

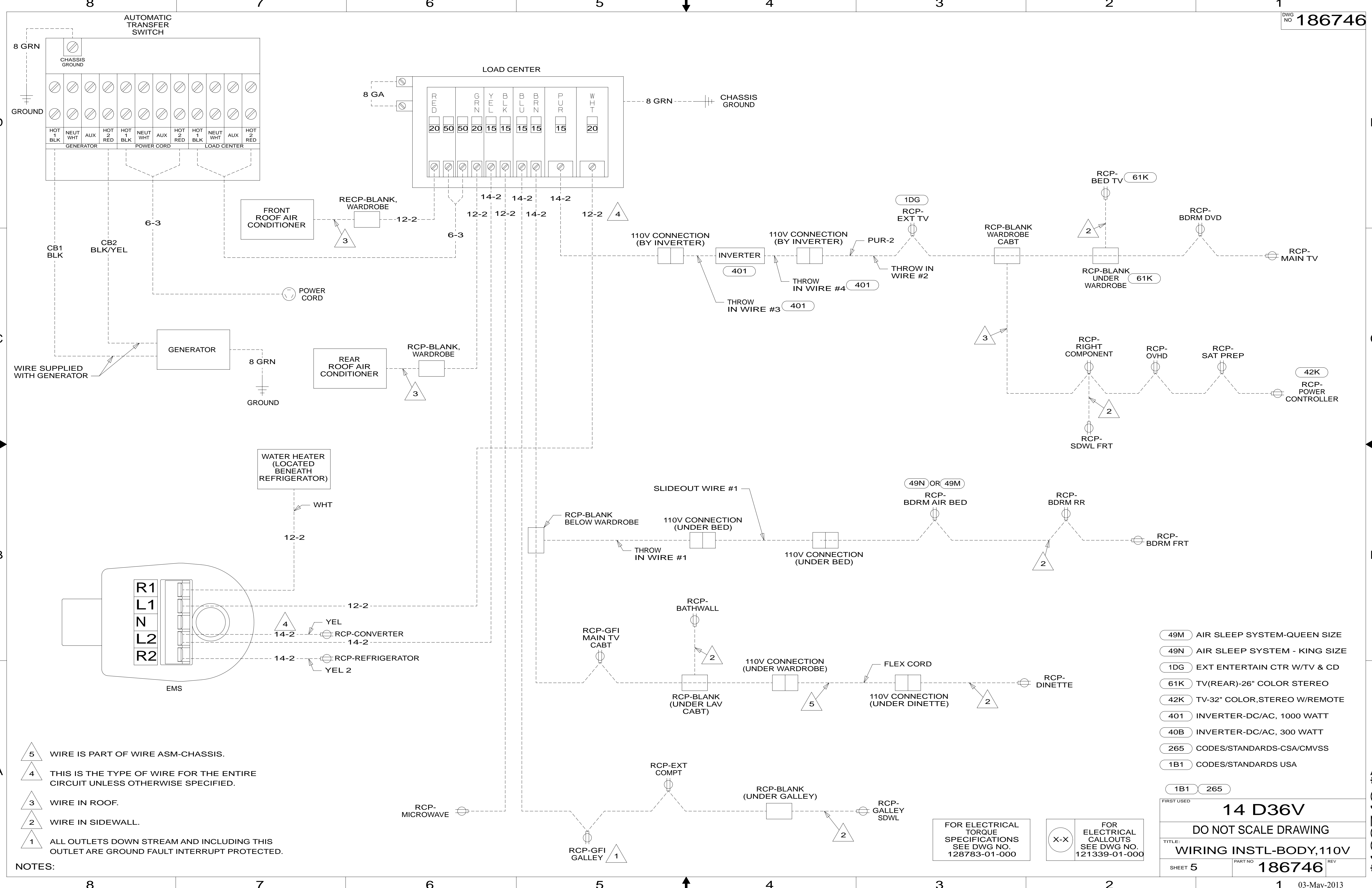

- NOTES:
- 5 WIRE IS PART OF WIRE ASM-CHASSIS.
 - 4 THIS IS THE TYPE OF WIRE FOR THE ENTIRE CIRCUIT UNLESS OTHERWISE SPECIFIED.
 - 3 WIRE IN ROOF.
 - 2 WIRE IN SIDEWALL.
 - 1 ALL OUTLETS DOWN STREAM AND INCLUDING THIS OUTLET ARE GROUND FAULT INTERRUPT PROTECTED.

- 49M AIR SLEEP SYSTEM-QUEEN SIZE
- 49N AIR SLEEP SYSTEM - KING SIZE
- 1DG EXT ENTERTAIN CTR W/TV & CD
- 61K TV(REAR)-26" COLOR STEREO
- 42K TV-32" COLOR,STEREO W/REMOTE
- 401 INVERTER-DC/AC, 1000 WATT
- 40B INVERTER-DC/AC, 300 WATT
- 265 CODES/STANDARDS-CSA/CMVSS
- 1B1 CODES/STANDARDS USA

FOR ELECTRICAL TORQUE SPECIFICATIONS SEE DWG NO. 128783-01-000

FOR ELECTRICAL CALLOUTS SEE DWG NO. 121339-01-000

FIRST USED	
14 D36V	
DO NOT SCALE DRAWING	
TITLE: WIRING INSTL-BODY, 110V	
SHEET 5	PART NO 186746 REV
03-May-2013	

* 186746 * A