



DANGER

Danger of electrical shock, burns or death. Always remove all power sources before attempting any repair, service or diagnostic work. Power can be present from shore power, generator, inverter or battery. All power sources must be disabled and secured before performing any service.



CAUTION

If you lack the skills, tools or equipment to perform diagnostic or repair work leave such work to an authorized Winnebago Industries dealer or other qualified shop.

DRAWING NO.	SHEET
186593-01	1,2
186593-02	1,3

RELEASE	REV DATE A	DWG NO 186593
REV ZONE	REVISION RECORD	DATE DFR-ORIG

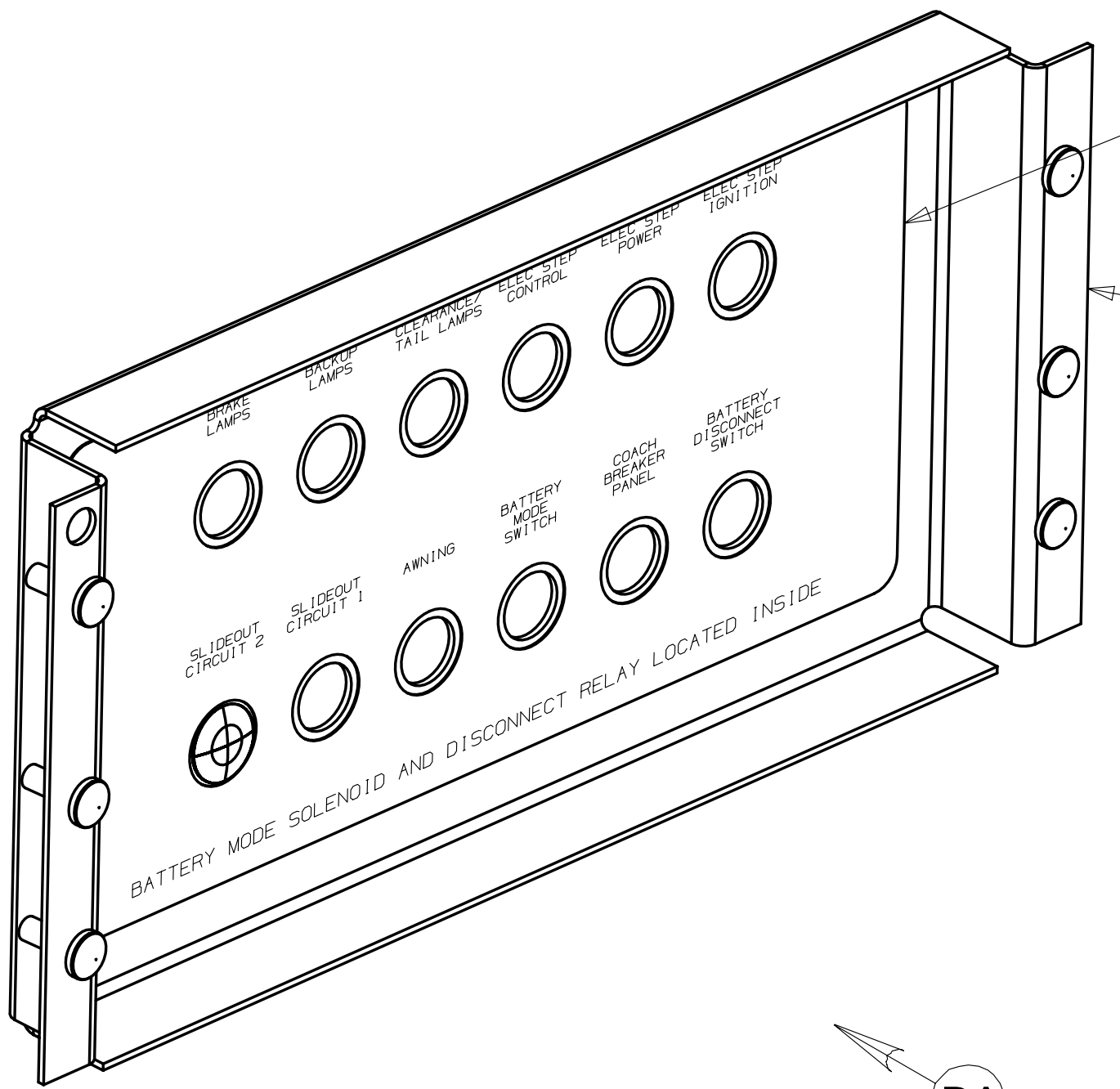
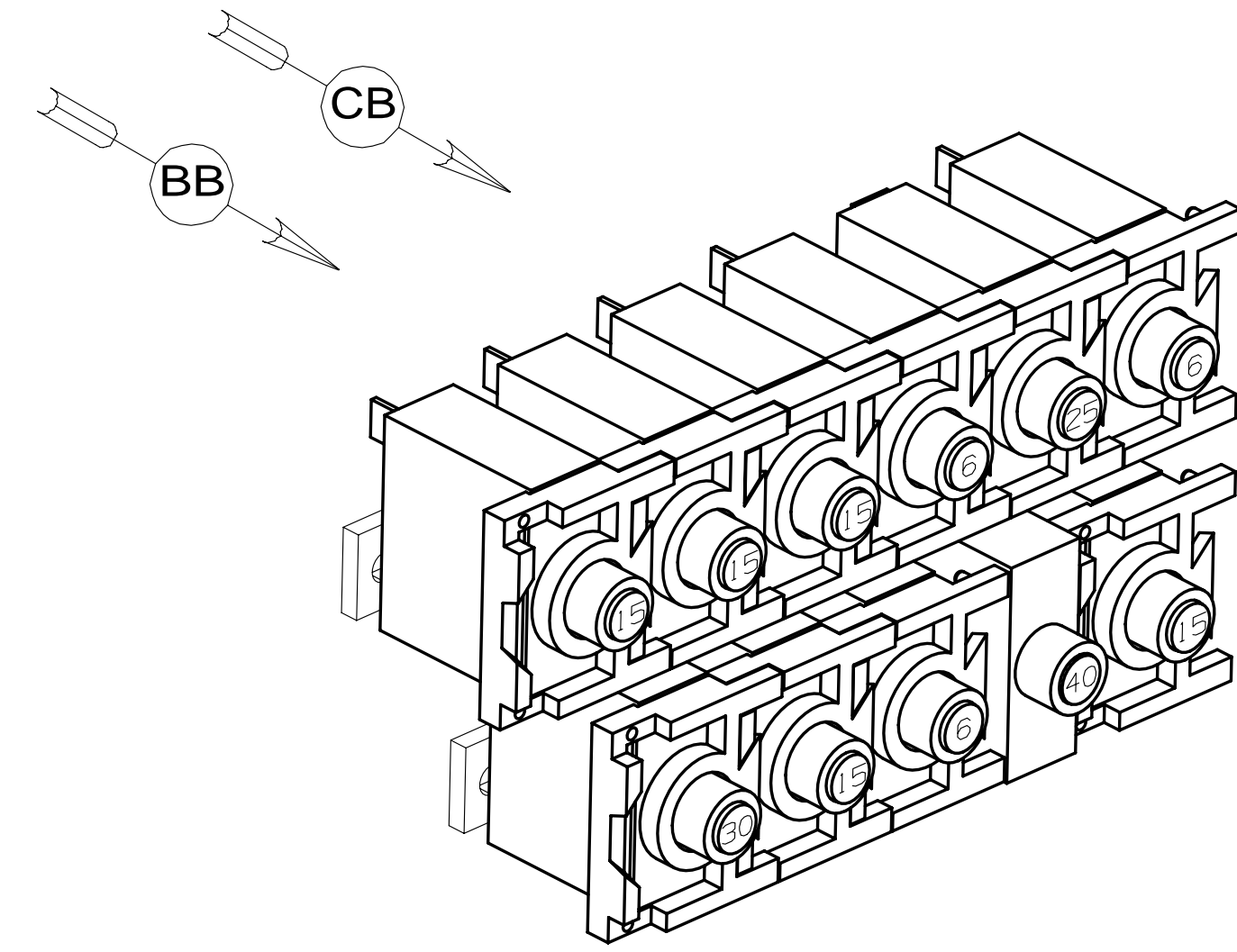

LABEL
93236-73-000

PLATE-CIRCUIT BREAKERS
161084-01-CHT
SCREW
G39-08-08U (6)

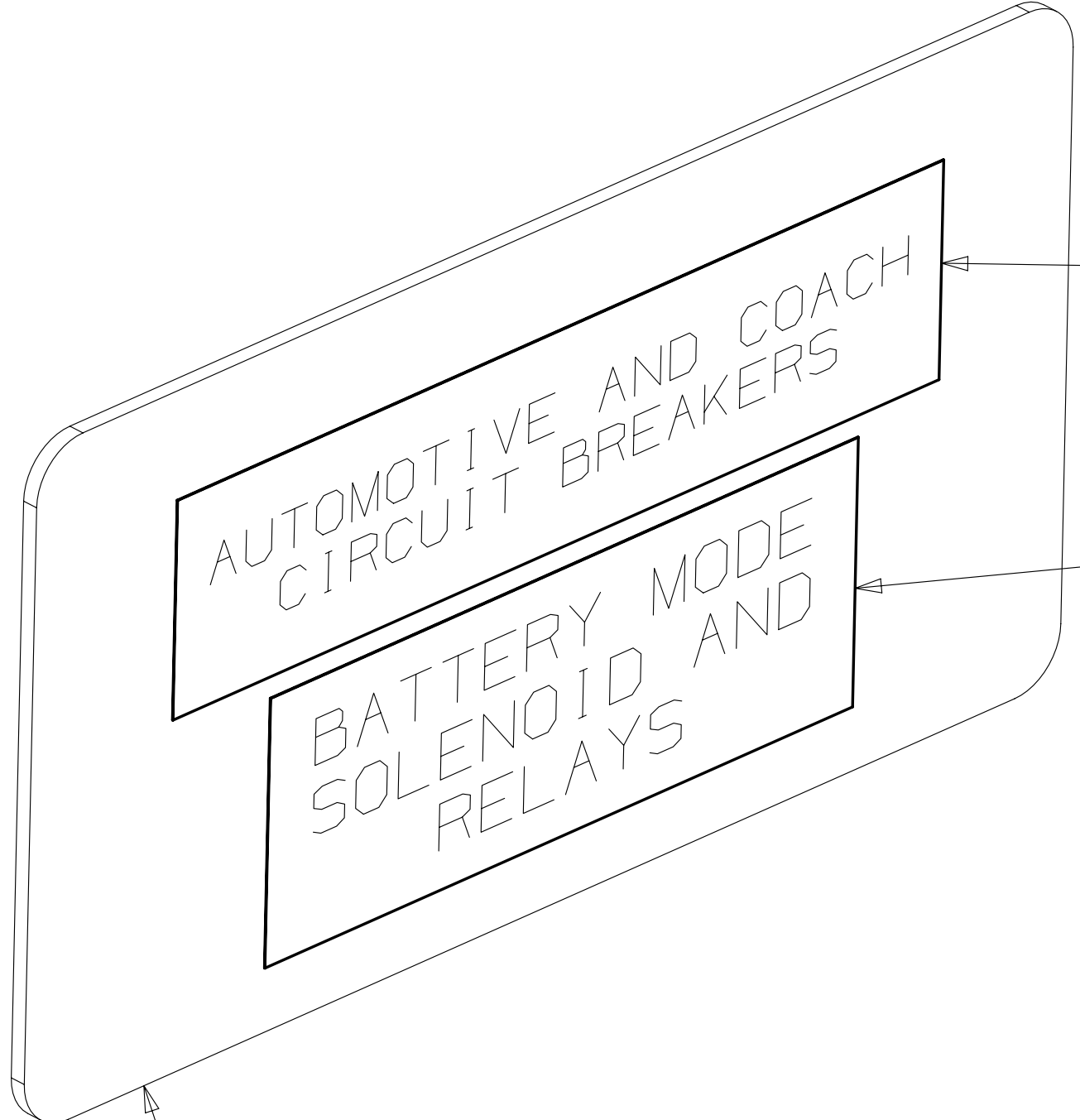
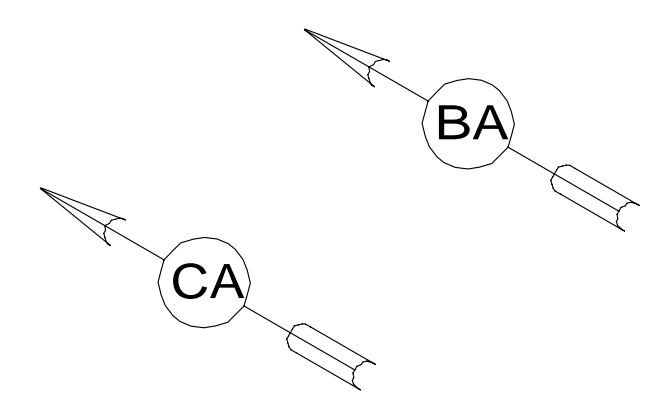

LABEL
98379-01-000

LABEL
98379-04-000

COVER 1

1 SUPPLIED WITH CHASSIS.

FOR ELECTRICAL TORQUE SPECIFICATIONS SEE DWG NO. 128783-01-000

FOR ELECTRICAL CALLOUTS SEE DWG NO. 121339-01-000

WINNEBAGO INDUSTRIES, INC. COPYRIGHT 2013 WINNEBAGO INDUSTRIES, INC.

DFTR	ORIG. DATE
CHKR	ALL DIMENSIONS ARE IN MILLIMETERS
P.E.	
M.E.	FIRST USED
DSNR	14 500-SERIES
UNSPECIFIED TOLERANCES ARE:	
WHOLE DIM (X)	: 3
ONE-PLACE (X.X)	: 1.5
TWO-PLACE (X.XX)	: 0.50
ANGLE	: 1°
THIRD ANGLE PROJECTION	
DO NOT SCALE DRAWING	REFER TO ES0018 FOR FASTENER TIGHTENING GUIDELINES
TITLE: CHASSIS ELECTRICAL BOX ASM	
SHEET 1 OF 3	PART NO 186593 REV
REF: 1	02-Aug-2013

* 186593 * A

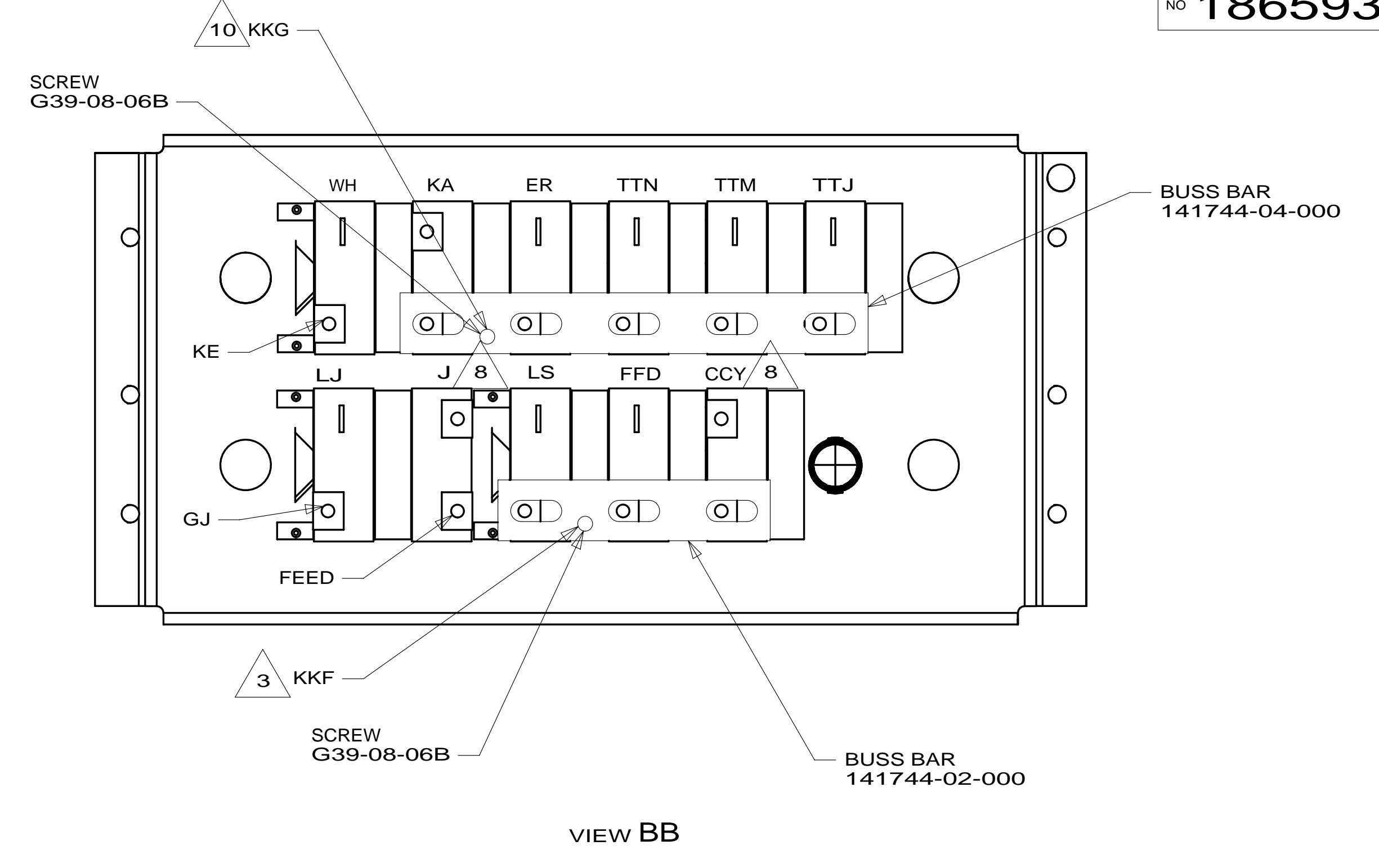
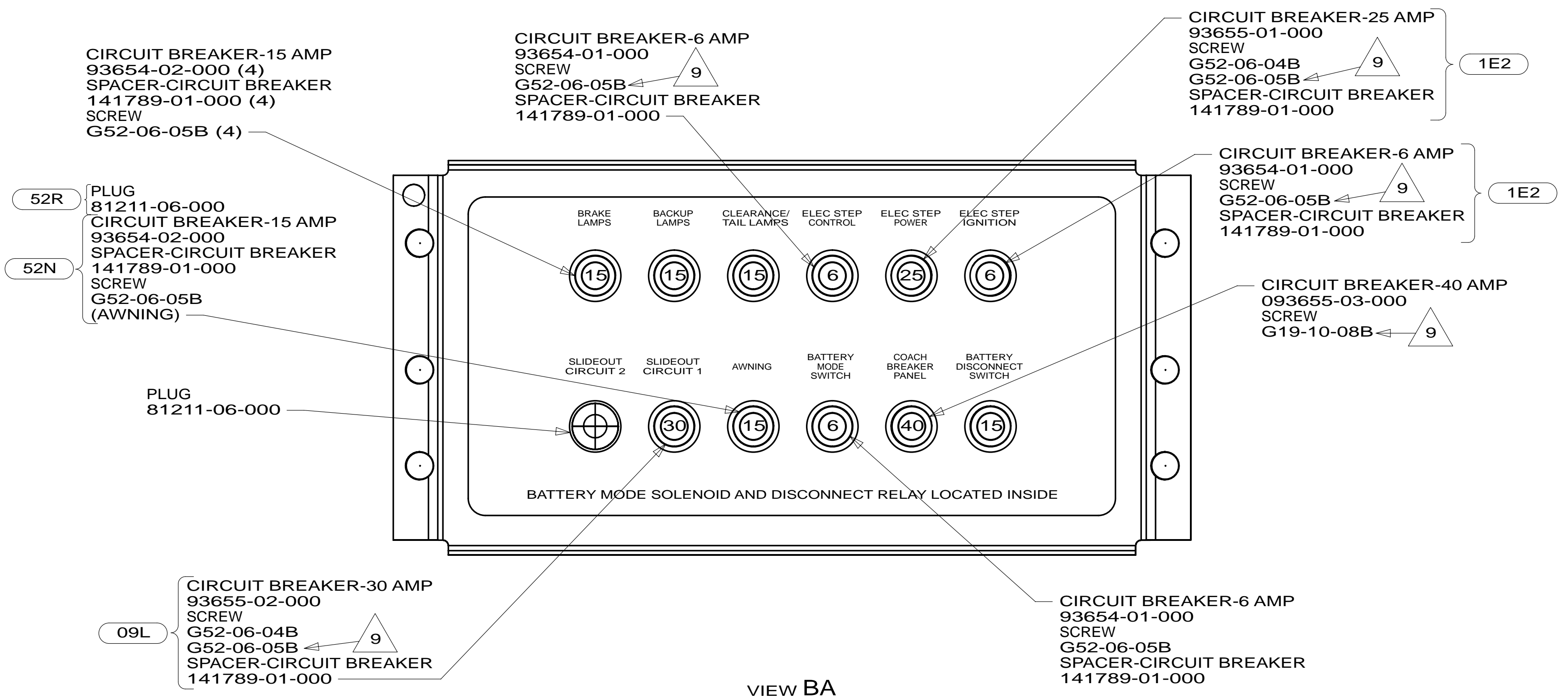

VIEW BA

VIEW BB

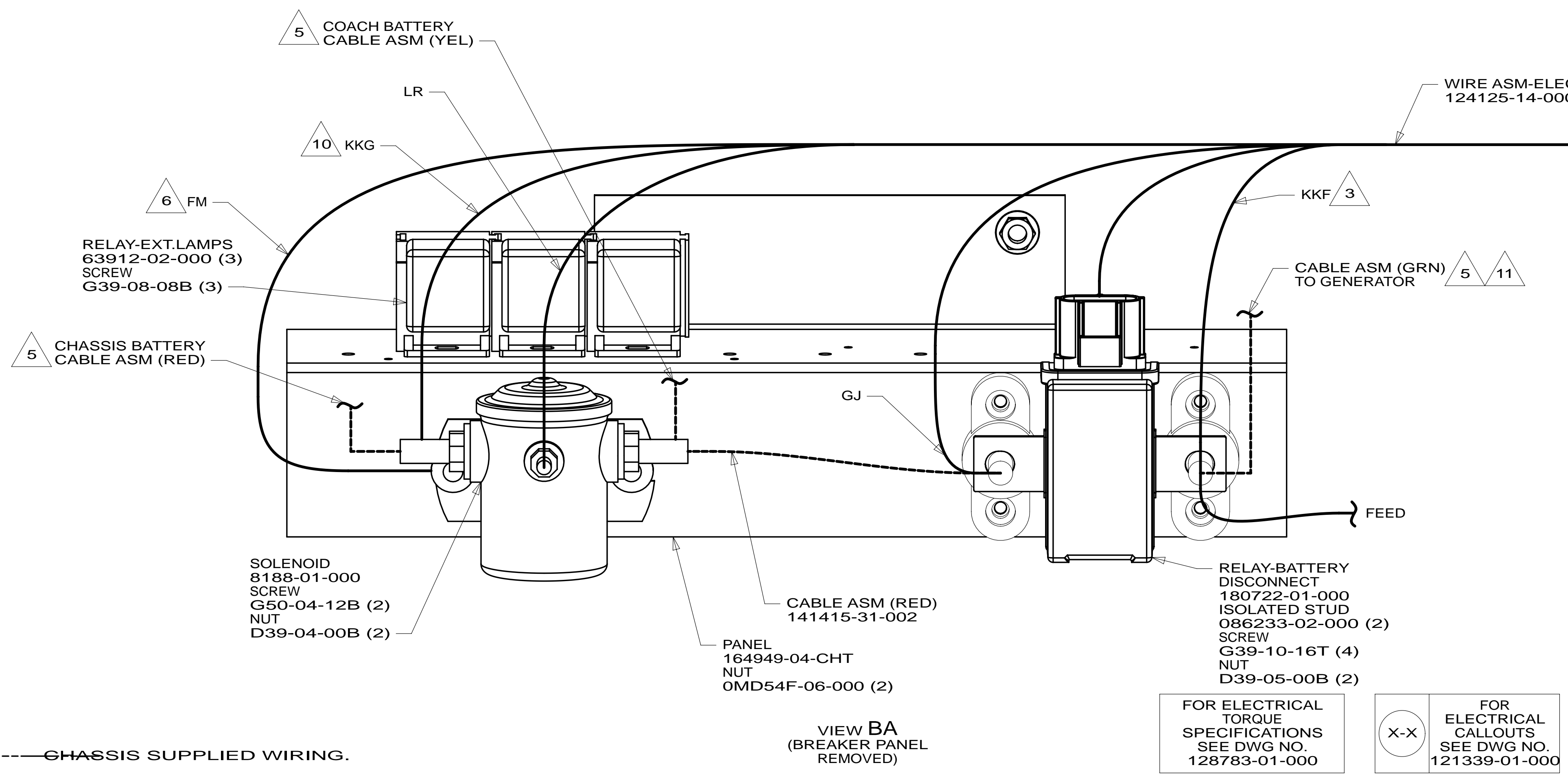

VIEW BA (BREAKER PANEL REMOVED)

- 11 WITH FEATURE 321 OR 323 DO NOT CONNECT CABLE ASM-GENERATOR (GRN) TO SOLENOID. TAPE END WITH TAPE 8363-01-000 AND LEAVE CABLE END LOOSE IN ELECTRICAL BOX.
- 10 WIRE IS MARKED WITH RED TAPE.
- 9 REPLACE EXISTING SCREW TO PROPERLY ATTACH BREAKER TO BUSS BAR.
- 8 CIRCUIT IS FROM WIRE ASM-CHASSIS.
- 7 WITHOUT 09P.
- 6 SECURE WITH SOLENOID MOUNTING SCREW.
- 5 WIRING INSTL-CHASSIS FOR ADDITIONAL INFORMATION.
- 4 TAPE BACK UNUSED WIRES TO HARNESS.
- 3 WIRE IS MARKED WITH YELLOW TAPE.
- 2 WIRE IS MARKED WITH PURPLE TAPE.

1. LEGEND: — WINNEBAGO; - - - - - GABLE; - - - - - CHASSIS SUPPLIED WIRING.

- 09L SLIDEOUT ROOM FRONT LEFT
- 09P SLIDEOUT ROOM - BACKWALL
- 52R AWNING PATIO WITHOUT
- 52N AWNING - PATIO, ELECTRIC
- 40B INVERTER-DC/AC, 300 WATT
- 09P SLIDEOUT ROOM - BACKWALL
- 323 GENERATOR PREP KIT - DIESEL
- 321 GENERATOR PREP KIT
- 1E2 ENTRANCE STEP-ELEC.
- 09L SLIDEOUT ROOM FRONT LEFT
- 40A INVERTER-DC/AC WITHOUT
- 1MD MERCEDES-11,030# GVWR,DIESEL
- 265 CODES/STANDARDS-CSA/CMVSS
- 1B1 CODES/STANDARDS USA

1B1 265 1MD

FIRST USED

14 500-SERIES

DO NOT SCALE DRAWING

TITLE: CHASSIS ELECTRICAL BOX ASM

SHEET 2 PART NO 186593 REV

02-Aug-2013

FOR ELECTRICAL TORQUE SPECIFICATIONS SEE DWG NO. 128783-01-000

FOR ELECTRICAL CALLOUTS SEE DWG NO. 121339-01-000

* 186593

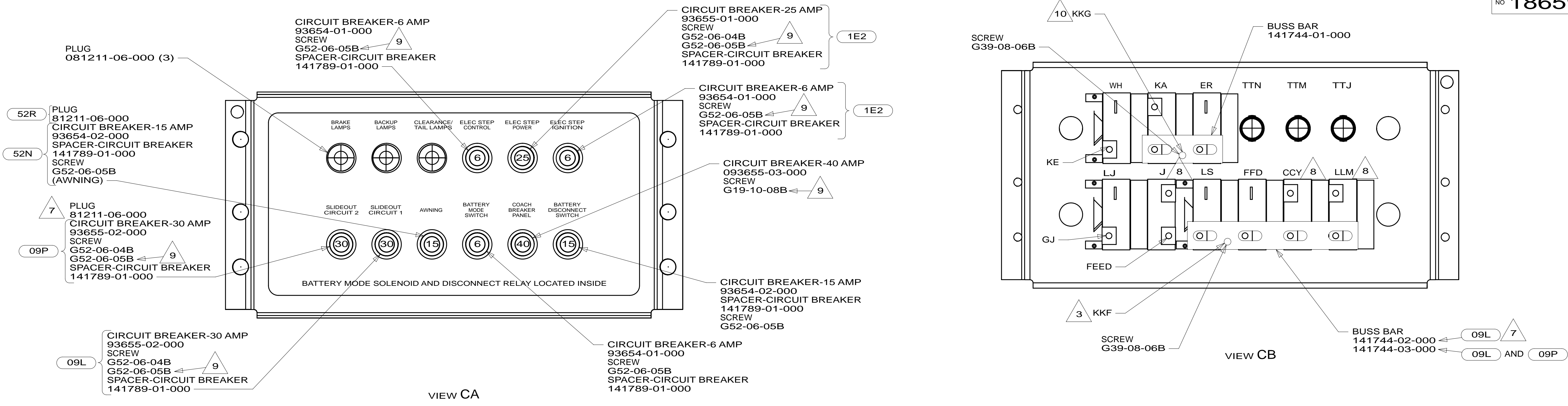

- 11 WITH FEATURE 321 OR 323 NOT CONNECT CABLE ASM-GENERATOR (GRN) TO SOLONOID. TAPE END WITH TAPE 8363-01-000 AND LEAVE CABLE END LOOSE IN ELECTRICAL BOX.
- 10 WIRE IS MARKED WITH RED TAPE.
- 9 REPLACE EXISTING SCREW TO PROPERLY ATTACH BREAKER TO BUSS BAR.
- 8 CIRCUIT IS FROM WIRE ASM-CHASSIS.
- 7 WITHOUT 09P.
- 6 SECURE WITH SOLENOID MOUNTING SCREW.
- 5 WIRING INSTL-CHASSIS FOR ADDITIONAL INFORMATION.
- 4 TAPE BACK UNUSED WIRES TO HARNESS.
- 3 WIRE IS MARKED WITH YELLOW TAPE.
- 2 WIRE IS MARKED WITH PURPLE TAPE.

1. LEGEND: — WINNEBAGO; - - - - - GABLE; - - - - - CHASSIS SUPPLIED WIRING.

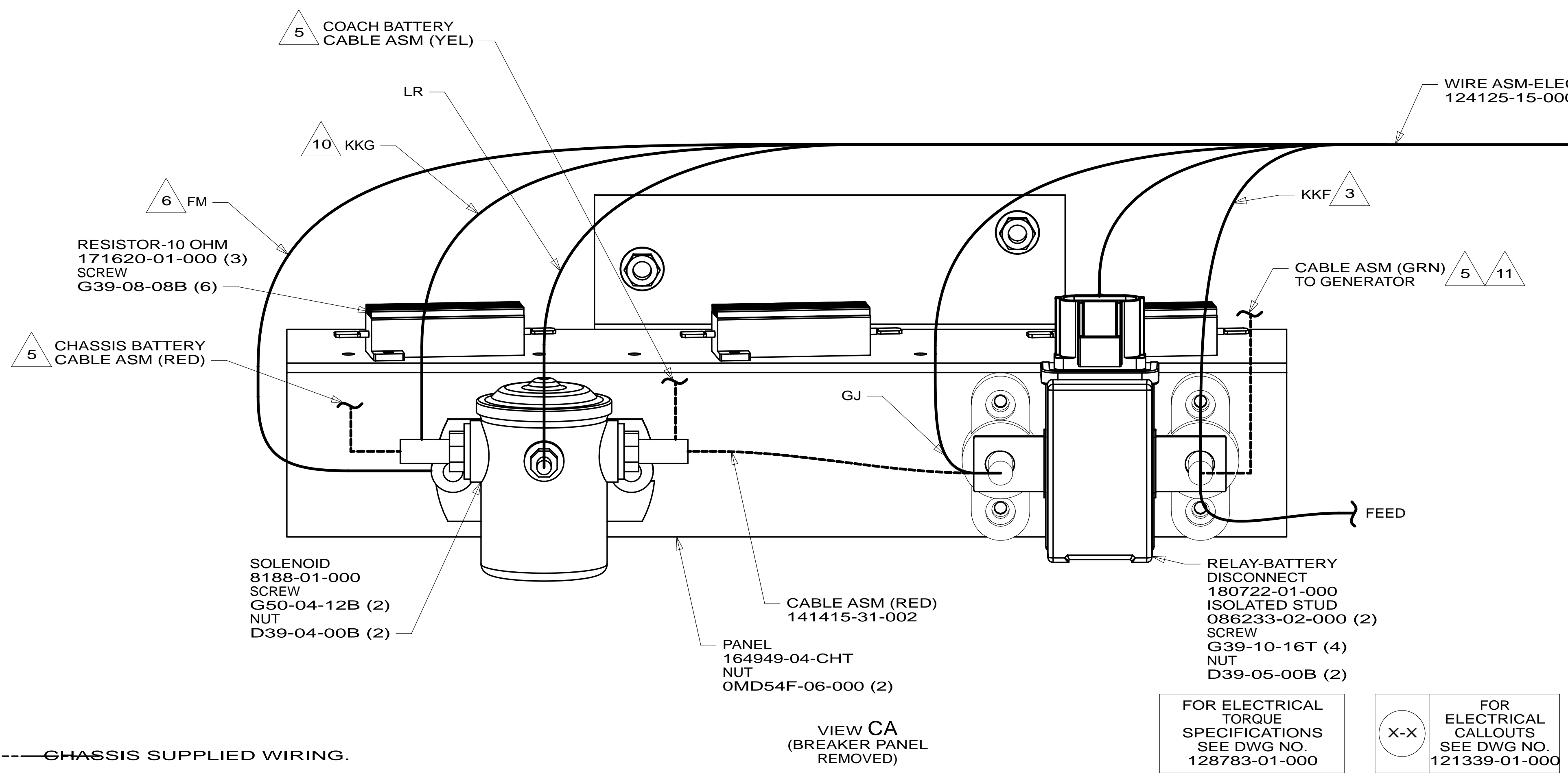

- 09L SLIDEOUT ROOM FRONT LEFT
- 09P SLIDEOUT ROOM - BACKWALL
- 52R AWNING PATIO WITHOUT
- 52N AWNING - PATIO, ELECTRIC
- 40B INVERTER-DC/AC, 300 WATT
- 09P SLIDEOUT ROOM - BACKWALL
- 323 GENERATOR PREP KIT - DIESEL
- 321 GENERATOR PREP KIT
- 1E2 ENTRANCE STEP-ELEC.
- 09L SLIDEOUT ROOM FRONT LEFT
- 40A INVERTER-DC/AC WITHOUT
- 1MD MERCEDES-11,030# GVWR,DIESEL
- 265 CODES/STANDARDS-CSA/CMVSS
- 1B1 CODES/STANDARDS USA

1B1 265 1MD

FIRST USED

14 500-SERIES

DO NOT SCALE DRAWING

TITLE: CHASSIS ELECTRICAL BOX ASM

SHEET 3 PART NO 186593 REV

02-Aug-2013

FOR ELECTRICAL TORQUE SPECIFICATIONS SEE DWG NO. 128783-01-000

FOR ELECTRICAL CALLOUTS SEE DWG NO. 121339-01-000

VIEW CA (BREAKER PANEL REMOVED)

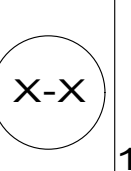

* 186593