

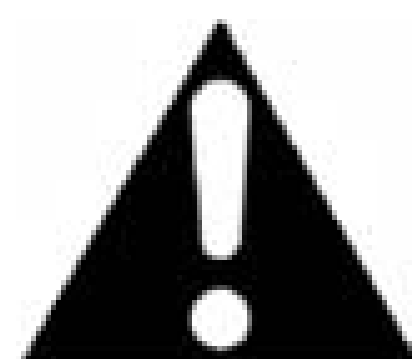

DANGER

Danger of electrical shock, burns or death. Always remove all power sources before attempting any repair, service or diagnostic work. Power can be present from shore power, generator, inverter or battery. All power sources must be disabled and secured before performing any service.



CAUTION

If you lack the skills, tools or equipment to perform diagnostic or repair work leave such work to an authorized Winnebago Industries dealer or other qualified shop.

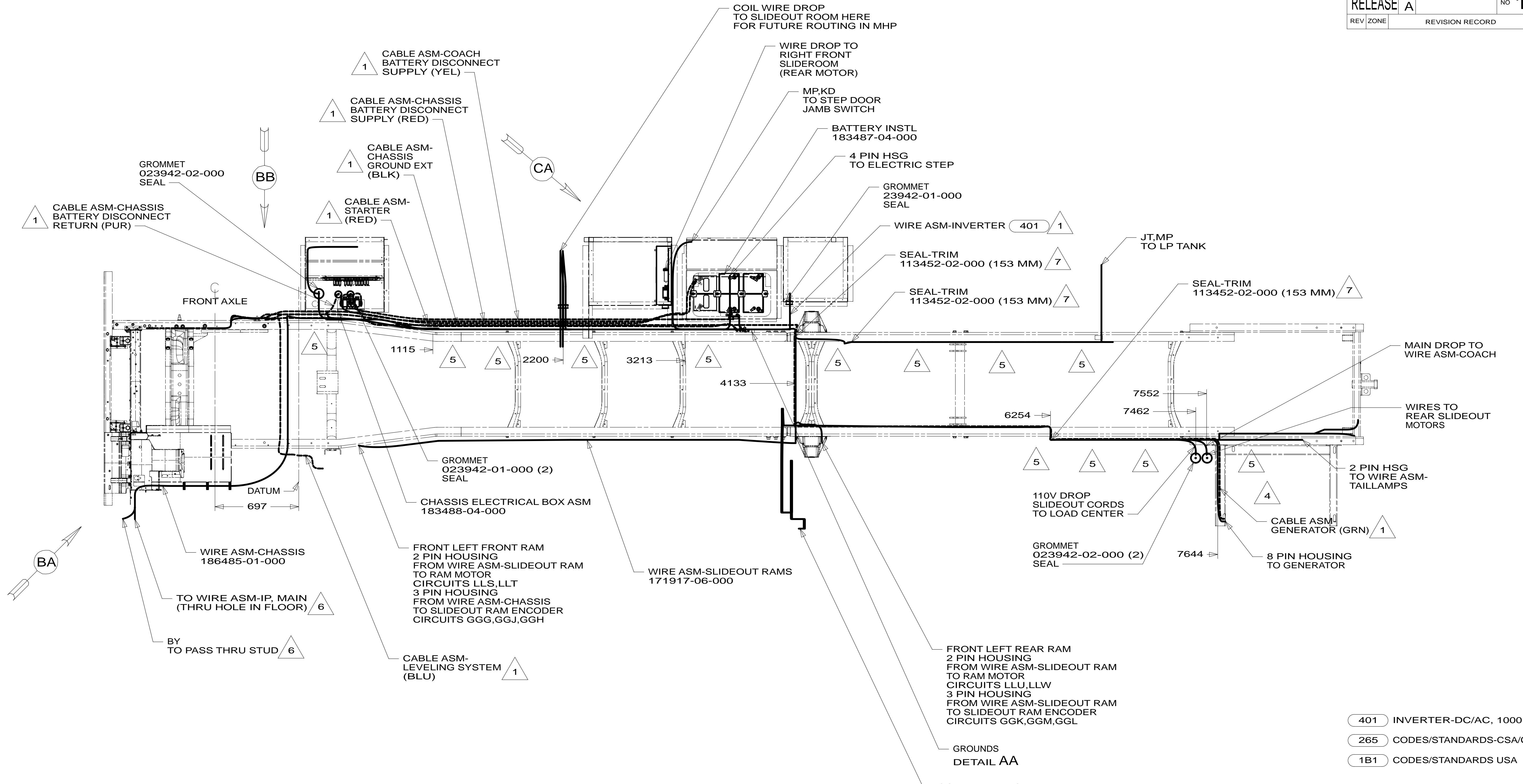

- 7 COVER SHARP EDGES WHERE WIRE CROSSES FRAME RAIL.
- 6 SEE WIRING INSTL-FRONT END FOR ADDITIONAL INFORMATION.
- 5 CLAMP 83610-01-000, SCREW G11-10-16B.
- 4 WIRE TIE 8343-04-000. FASTEN EVERY 600MM MINIMUM.
- 3. ALL DIMENSIONS ARE FROM DATUM UNLESS OTHERWISE SPECIFIED.
- 2. SECURE CONDUIT 41953, TAB AS REQUIRED, OVER ALL WIRES IN CONTACT WITH SHARP EDGES.
- 1 SEE BATTERY INSTALLATION FOR ADDITIONAL INFORMATION.

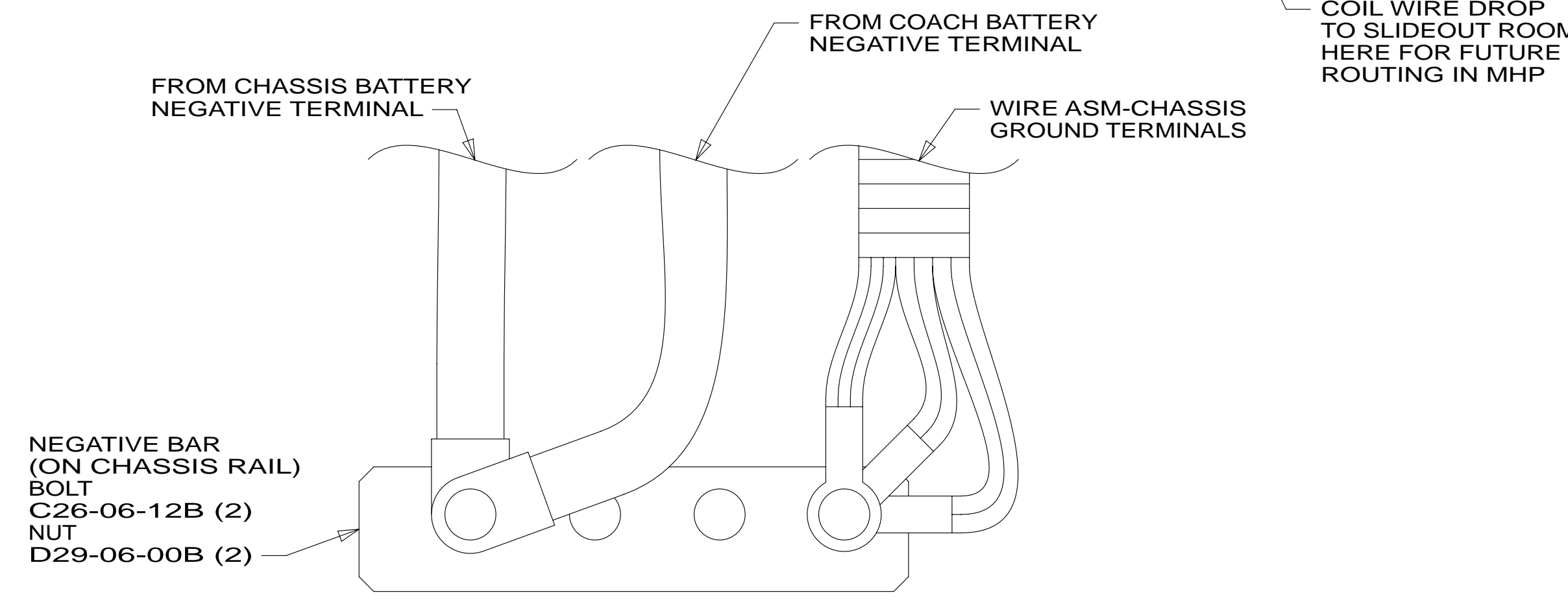

- 401 INVERTER-DC/AC, 1000 WATT
- 265 CODES/STANDARDS-CSA/CMVSS
- 1B1 CODES/STANDARDS USA
- 1B1 265

WINNEBAGO COPYRIGHT 2013 WINNEBAGO INDUSTRIES, INC.

DFTR	ORIG. DATE
CHKR	ALL DIMENSIONS ARE IN MILLIMETERS
P.E.	
M.E.	FIRST USED
DSNR	14 D35G
UNSPECIFIED TOLERANCES ARE:	
WHOLE DIM (X)	: 3
ONE-PLACE (X.X)	: 1.5
TWO-PLACE (X.XX)	: 0.50
ANGLE	: 1°
THIRD ANGLE PROJECTION	
DO NOT SCALE DRAWING	REFER TO ES0018 FOR FASTENER TIGHTENING GUIDELINES
TITLE: WIRING INSTL-CHASSIS	
SHEET 1 OF 3	PART NO 186482 REV
REF:	1 20-May-2013

FOR ELECTRICAL TORQUE SPECIFICATIONS SEE DWG NO. 128783-01-000

X-X FOR ELECTRICAL CALLOUTS SEE DWG NO. 121339-01-000

* 186482 *

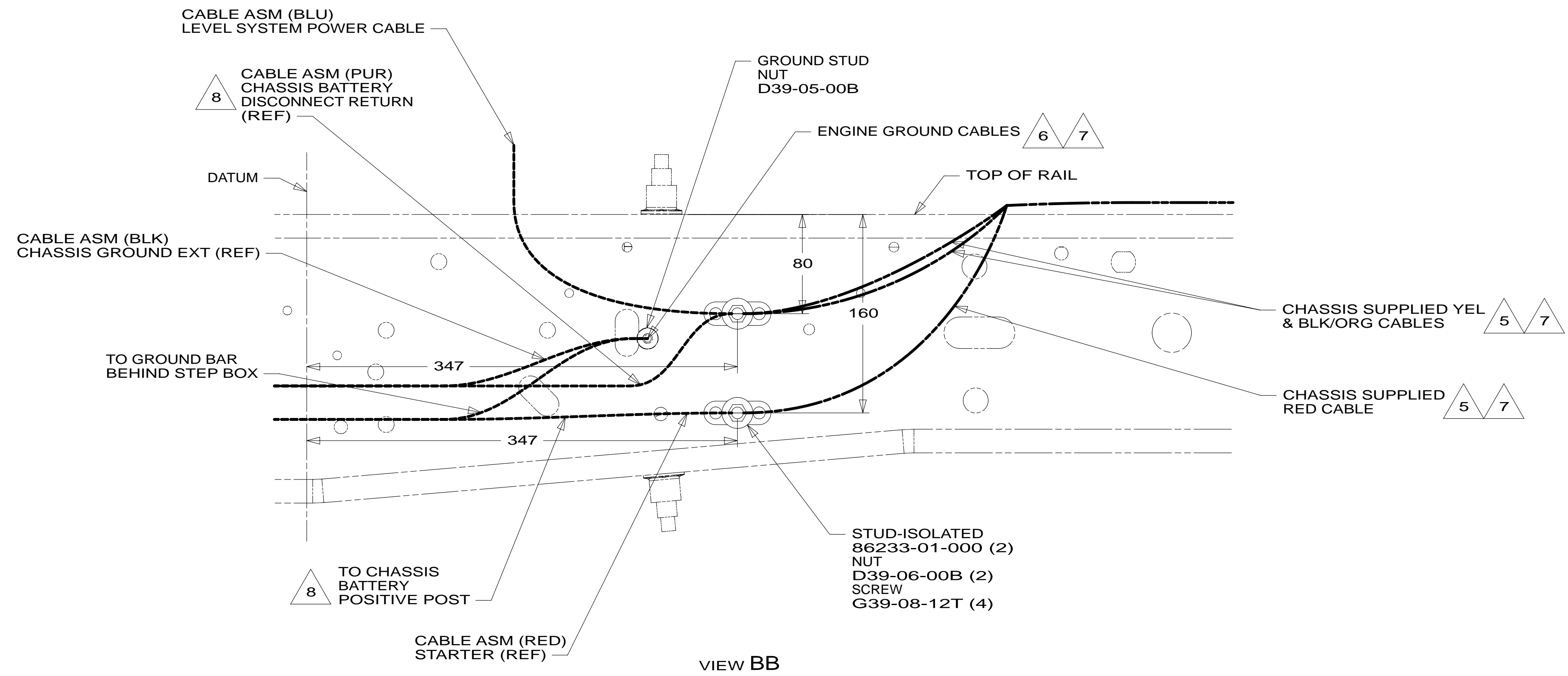

VIEW BB

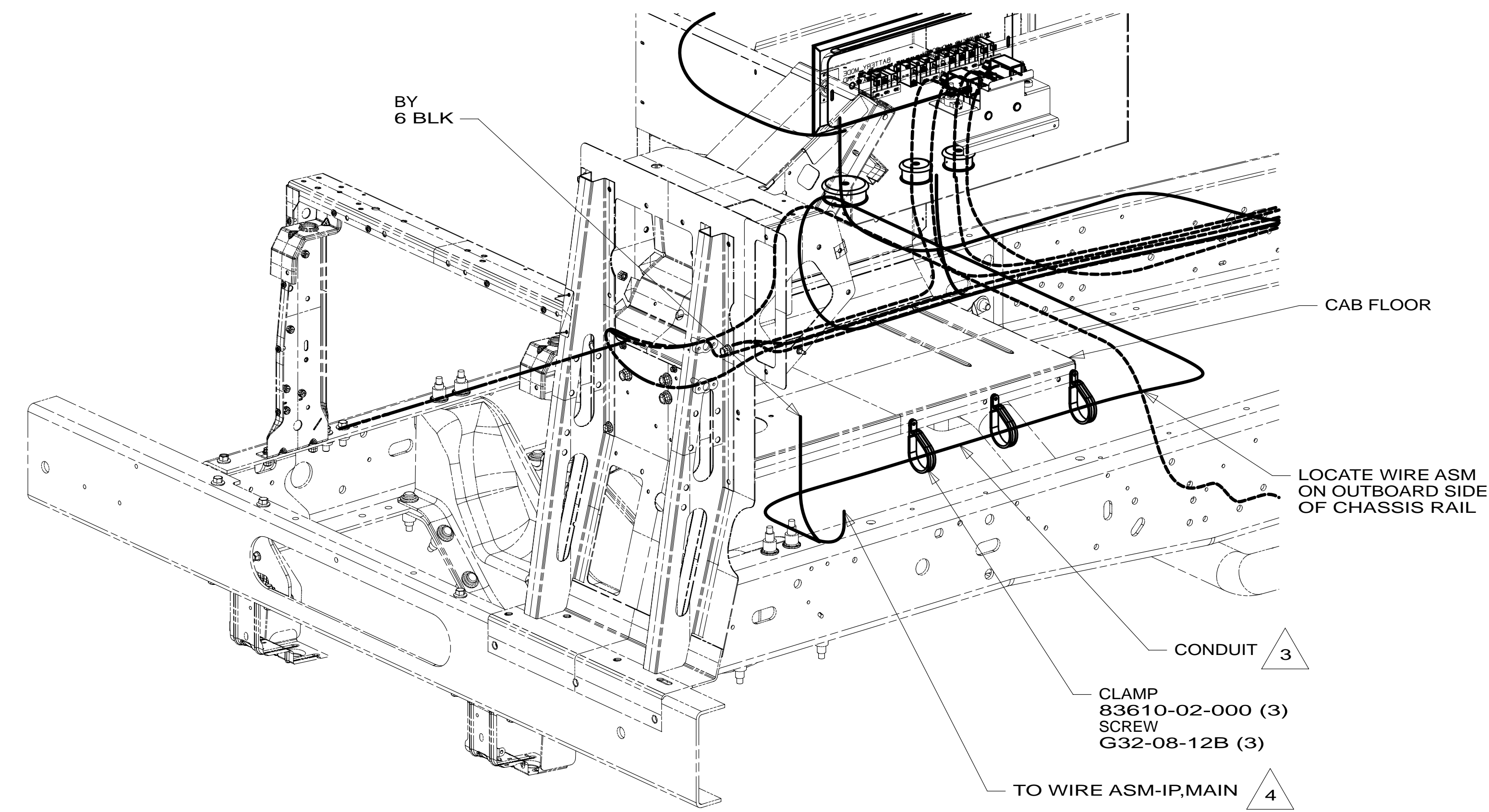

VIEW BA

- 8 SEE BATTERY INSTL FOR ADDITIONAL INFORMATION.
- 7 SUPPLIED WITH CHASSIS
- 6 CUT CHASSIS SUPPLIED BATTERY GROUND CABLE 700MM FROM BATTERY TERMINAL AND ADD TERMINAL 8348-01-000 TO CUT END.
- 5 CUT CHASSIS SUPPLIED POSITIVE BATTERY CABLE 150MM FROM BATTERY TERMINAL END, DISCARD TERMINAL END AND SEPARATE WIRES. ADD TERMINAL 8348-01-000 AND HEAT SHRINK 176567-04-000 TO RED CABLE (CHASSIS STARTER) AND COMBINE YELLOW (CHASSIS POWER DISTRIBUTION) AND BLACK/ORANGE (CHASSIS ALTERNATOR) WIRES TOGETHER AND ADD TERMINAL 8348-01-000 AND HEAT SHRINK 176567-02-000. COIL EXCESS CABLE ALONG FRAME RAIL JUST BEHIND RADIATOR AND TIE UP WITH TIE-WIRE 8343-04-000.
- 4 ROUTE WIRE THRU HOLE IN CAB FLOOR.
- 3 COVER WITH CONDUIT 41953-10-000 AND 41953-11-000 AS REQUIRED.

2. CONNECT CABLES TO COACH SIDE OF BATTERY DISCONNECT WHEN BATTERY DISCONNECT IS USED.
1. CUT OFF EXCESS END OF WIRE TIE.

NOTES:

265 CODES/STANDARDS-CSA/CMVSS
 1B1 CODES/STANDARDS USA

1B1 265

FIRST USED **14 D35G**

DO NOT SCALE DRAWING

TITLE: **WIRING INSTL-CHASSIS**

SHEET 2 PART NO **186482** REV

FOR ELECTRICAL TORQUE SPECIFICATIONS SEE DWG NO. 128783-01-000

FOR ELECTRICAL CALLOUTS SEE DWG NO. 121339-01-000

* 186482 *

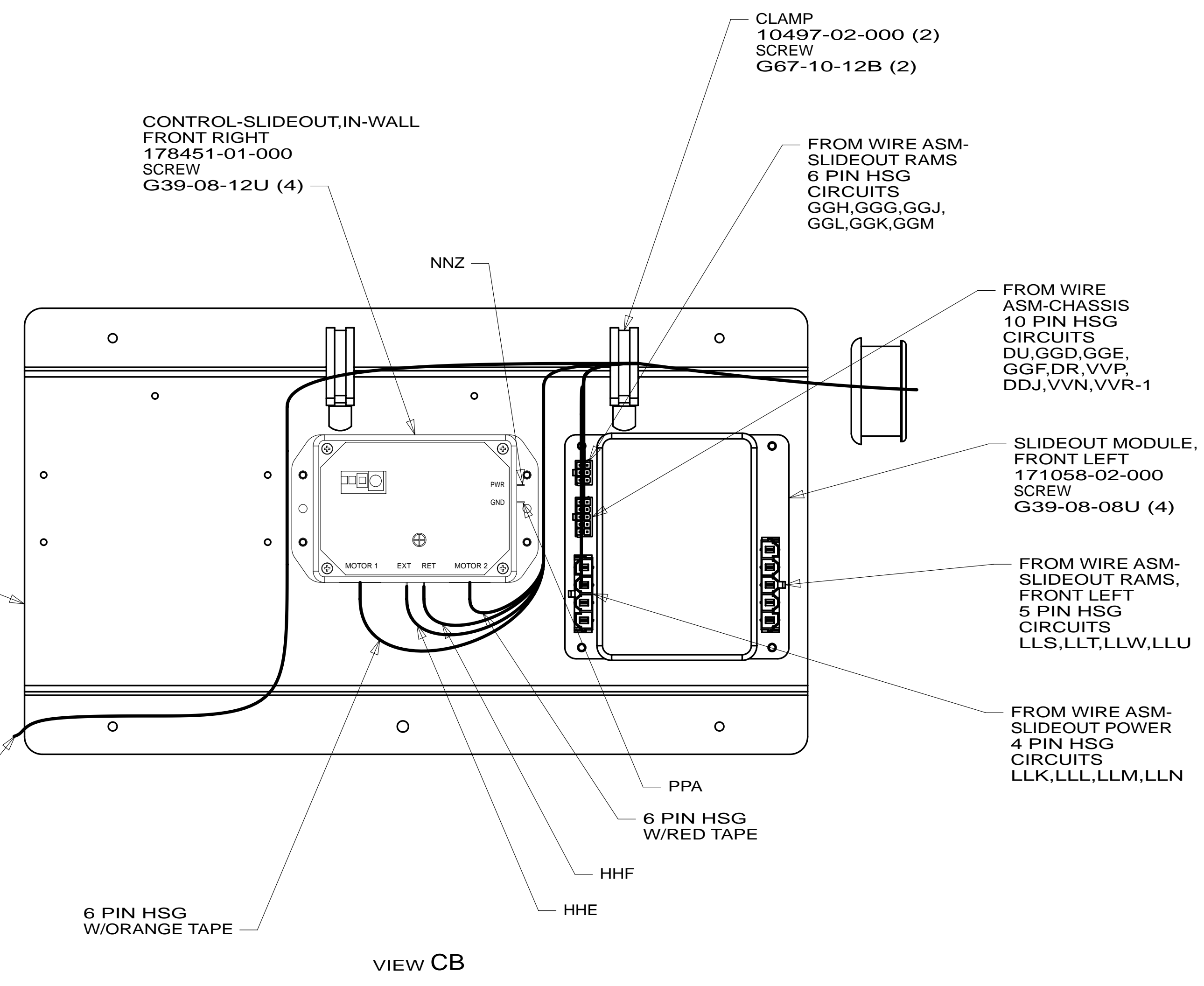
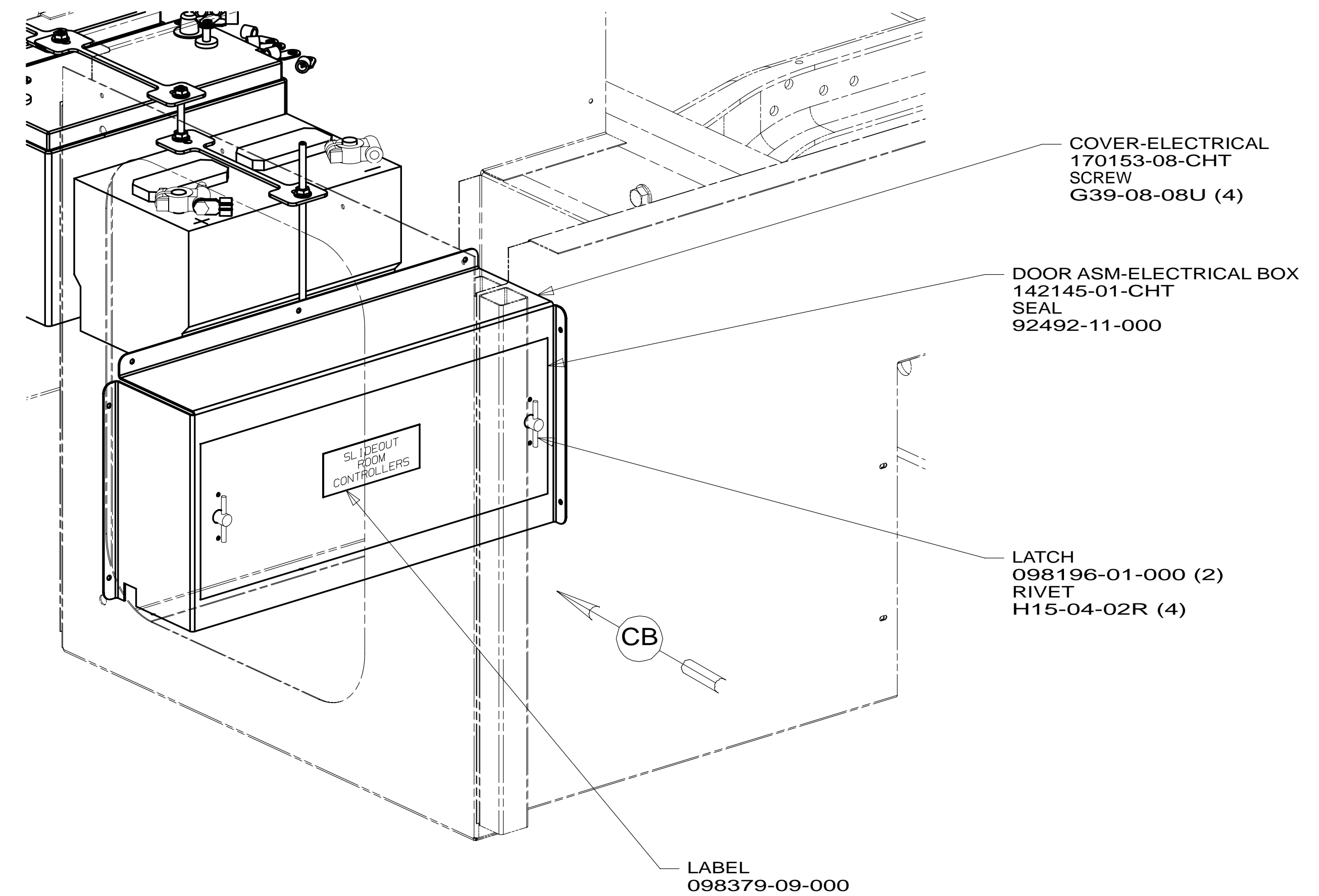

1 SEE CHASSIS ELECTRICAL BOX ASM FOR ADDITIONAL INFORMATION.

FOR ELECTRICAL
TORQUE
SPECIFICATIONS
SEE DWG NO.
128783-01-000

X-X
FOR
ELECTRICAL
CALLOUTS
SEE DWG NO.
121339-01-000

265 CODES/STANDARDS-CSA/CMVSS
1B1 CODES/STANDARDS USA
1B1 265

FIRST USED	14 D35G	
DO NOT SCALE DRAWING		
TITLE:	WIRING INSTL-CHASSIS	
SHEET 3	PART NO 186482	REV

* 186482 * A