



DANGER

Danger of electrical shock, burns or death. Always remove all power sources before attempting any repair, service or diagnostic work. Power can be present from shore power, generator, inverter or battery. All power sources must be disabled and secured before performing any service.



CAUTION

If you lack the skills, tools or equipment to perform diagnostic or repair work leave such work to an authorized Winnebago Industries dealer or other qualified shop.

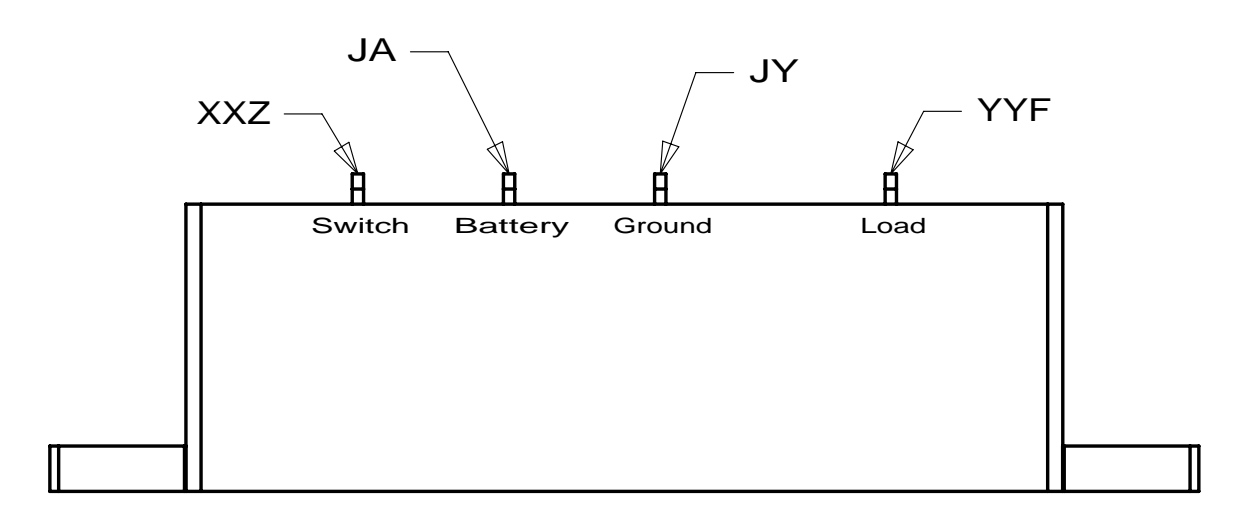
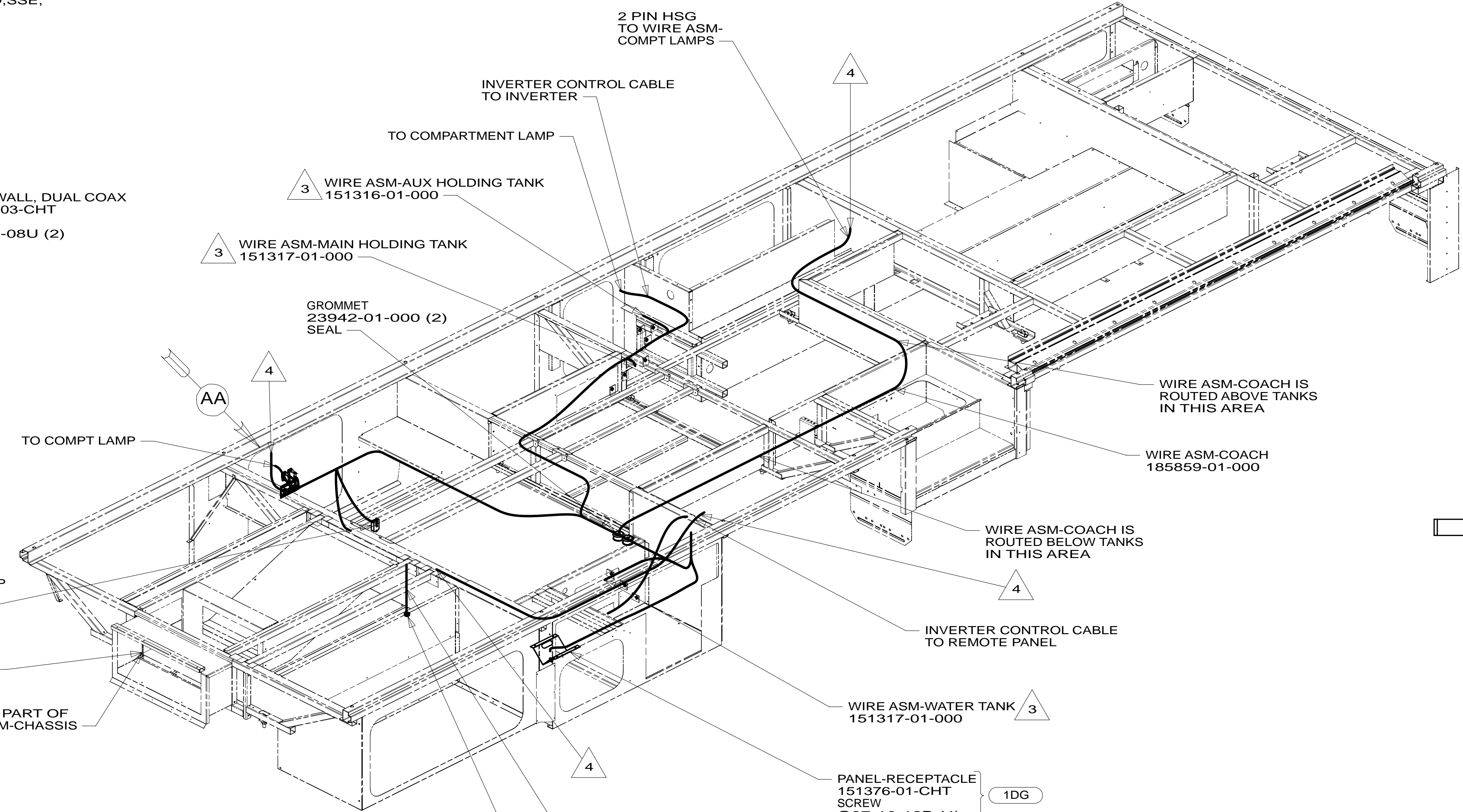
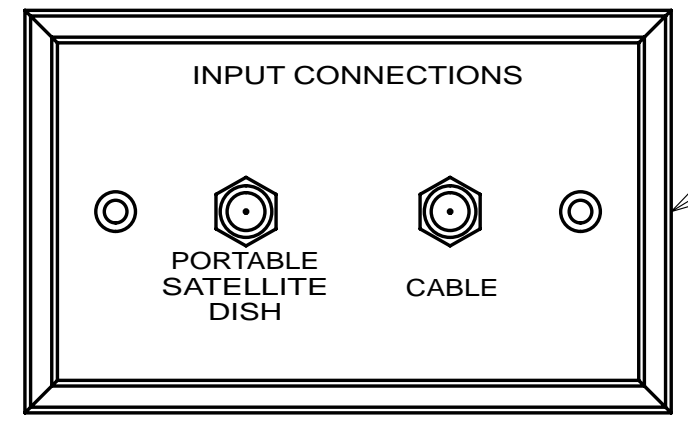
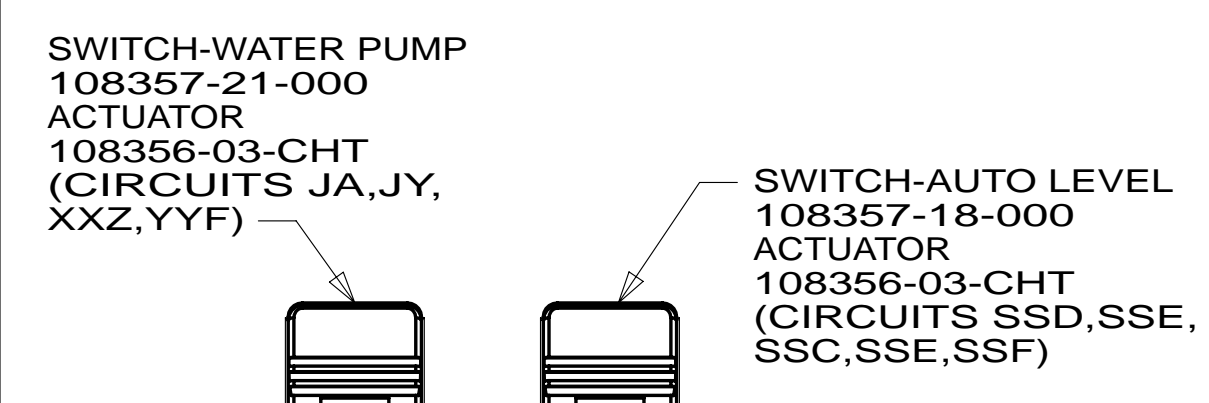

- NOTES:
- 4 WIRE PASSES THROUGH FLOOR IN THIS AREA.
 - 3 PLACE CROSS LOCATOR ON SENSOR OVER DIMPLES ON TANK.
 - 2. ROUTE TANK SENSOR WIRES SO THEY DO NOT PASS OVER SENSORS. USE WIRE TIE MOUNT 155366-01-000 AND WIRE TIE 8343-01-000 AS NEEDED. TANK SURFACE MUST BE CLEANED USING ISOPROPYL ALCOHOL AND PRIMED WITH PRIMER 94.
 - 1. AT MINIMUM ALL WIRES TO BE SUPPORTED AND SECURED PER CODE REQUIREMENTS. USE CLAMP 10495 OR 10497 OR WIRE TIE 8343 OR 108046 AND SCREW G67-XX-XXX OR G56-XX-XXX AS APPROPRIATE FOR INSTALLATION.

- PANEL-RECEPTACLE 151376-01-CHT SCREW G67-10-12B (4) 1DG
- PANEL-RECEPTACLE 151376-02-CHT LABEL-COAX 157486-01-CHT ADAPTER 82134-01-000 NUT 82136-01-000 SCREW G67-10-12B (4) 299

- 1DG EXT ENTERTAIN CTR W/TV & CD
- 299 ENTERTAINMENT CENTER EXT.W/O
- 265 CODES/STANDARDS-CSA/CMVSS
- 1B1 CODES/STANDARDS USA

WINNEBAGO COPYRIGHT 2014 WINNEBAGO INDUSTRIES, INC.

| | |
|------|-----------------------------------|
| DTR | ORIG. DATE |
| CHKR | ALL DIMENSIONS ARE IN MILLIMETERS |
| P.E. | FIRST USED |
| M.E. | 14 D33C |
| DSNR | |

UNSPECIFIED TOLERANCES ARE:

| | |
|------------------|--------|
| WHOLE DIM (X) | : 3 |
| ONE-PLACE (X.X) | : 1.5 |
| TWO-PLACE (X.XX) | : 0.50 |
| ANGLE | : 1° |

THIRD ANGLE PROJECTION

DO NOT SCALE DRAWING REFER TO ES0018 FOR FASTENER TIGHTENING GUIDELINES

TITLE: **WIRING INSTL-BODY,12V**

SHEET 1 OF 8 PART NO **185856** REV

REF: 1 02-Jan-2014

FOR ELECTRICAL TORQUE SPECIFICATIONS SEE DWG NO. 128783-01-000

FOR ELECTRICAL CALLOUTS SEE DWG NO. 121339-01-000

* 185856 *

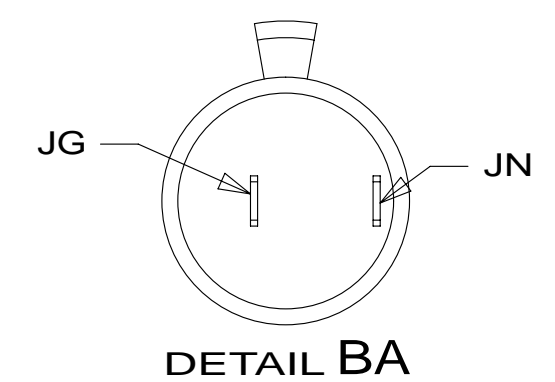

LAMP-DINETTE
93575-54-CHT
BULB
67479-01-000 (2)
CONNECTOR
58028-01-000 (2)
SCREW
G11-06-10U (2)

SWITCH
DETAIL DT

LED-2

4 PIN HSG
TO SIDEWALL

RCA & COAX
(GRN/GRN)
TO REAR TV

LIGHT-WARDROBE
87694-03-000
SCREW
G11-10-12U (2)
CONNECTOR
58028-01-000 (2)

THERMOSTAT
276 135618-04-CHT
29R 135618-03-CHT
SCREW
G13-07-12B (2)

PLATE-WALL,RCA
167733-01-CHT
SCREW
G12-06-080 (2)

PLATE-
SATELLITE
PREP
DETAIL BC

SWITCHES
DETAIL DA

4 PIN HSG TO
REAR AUTO HEATER

SECURE GROUND WIRE JP
TO SLIDEOUT FRAME IN
THIS AREA USING
SCREW
G39-10-12T

WIRE ASM-SLIDEOUT
186086-01-000 21R
186087-01-000 14W

ET,EU
TO REFRIGERATOR

WIRE ASM-CHASSIS
TO SLIDEOUT MOTORS
DETAIL HA

PLATE-WALL
149557-08-CHT
SCREW

COAX-ORG/ORG

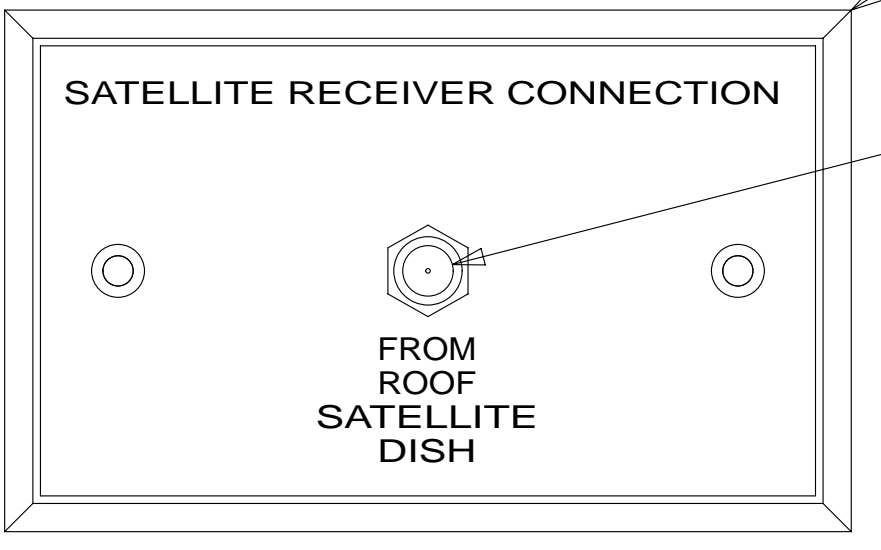

RECEPTACLE-12V
132958-01-000 14W
DETAIL BA

SPEAKER-SUB
124884-01-000
GRILLE-SPEAKER
151844-01-CHT
SCREW
G11-08-12U (4) 1JM

WIRE ASM-COACH
ROUTED WITH
WATER LINES & 110V WIRING

DETAIL BB 21R

LED-2
2

2 PIN HSG
TO WIRE ASM
SLIDEOUT ROOF

2 & 3 WAY RCA
CABLE
CAT6 CABLE
COAX
(UNMARKED)
TO TV

TO IR
RECEIVER

SWITCHES
DETAIL DB

DETAIL BB 21R

- 4 SEE WIRING INSTL-TV/DVD FOR ADDITIONAL INFORMATION.
- 3 WIRE FROM ROOF.
- 2 WIRE PASSES THROUGH FLOOR IN THIS AREA.

NOTES:
1. ALL WIRES TO BE SECURED WITH CLAMP 10495 OR 10497 OR WIRE TIE 8343 OR 108046 EVERY 600MM, USE SCREW G67-XX-XXX OR G56-XX-XXX AS APPROPRIATE FOR INSTALLATION.

- 21R DINING/BUFFET/POWERED TV
- 14W DINETTE
- 29R AC HEAT PUMP-2 HI EFFICIENCY
- 276 A/C ROOF-HI EFF (2) W/EMS
- 265 CODES/STANDARDS-CSA/CMVSS
- 1B1 CODES/STANDARDS USA

1B1 265

FIRST USED

14 D33C

DO NOT SCALE DRAWING

TITLE: **WIRING INSTL-BODY,12V**

SHEET 2 PART NO **185856** REV

FOR ELECTRICAL
TORQUE
SPECIFICATIONS
SEE DWG NO.
128783-01-000

X-X
FOR
ELECTRICAL
CALLOUTS
SEE DWG NO.
121339-01-000

* 185856 *

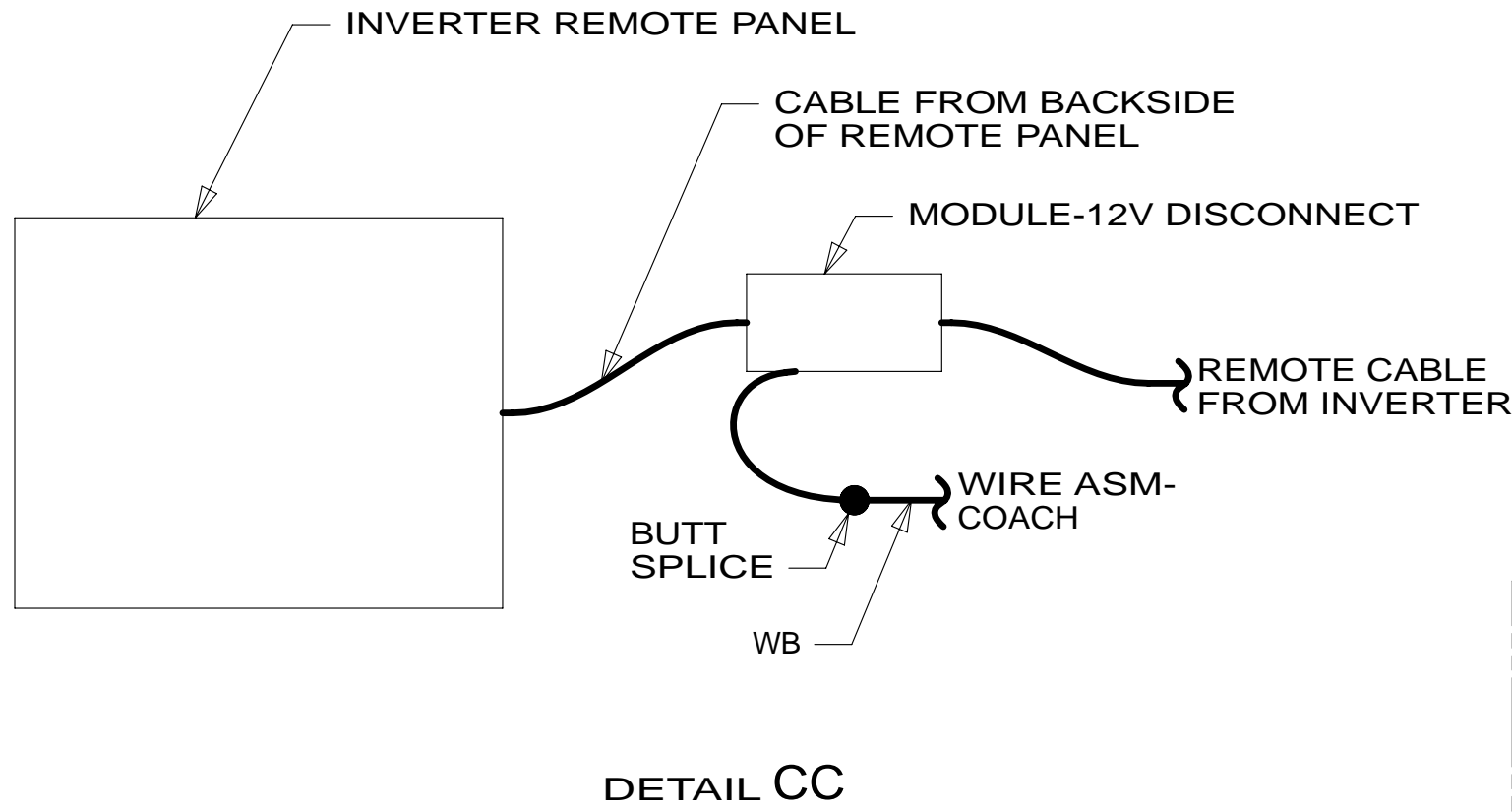
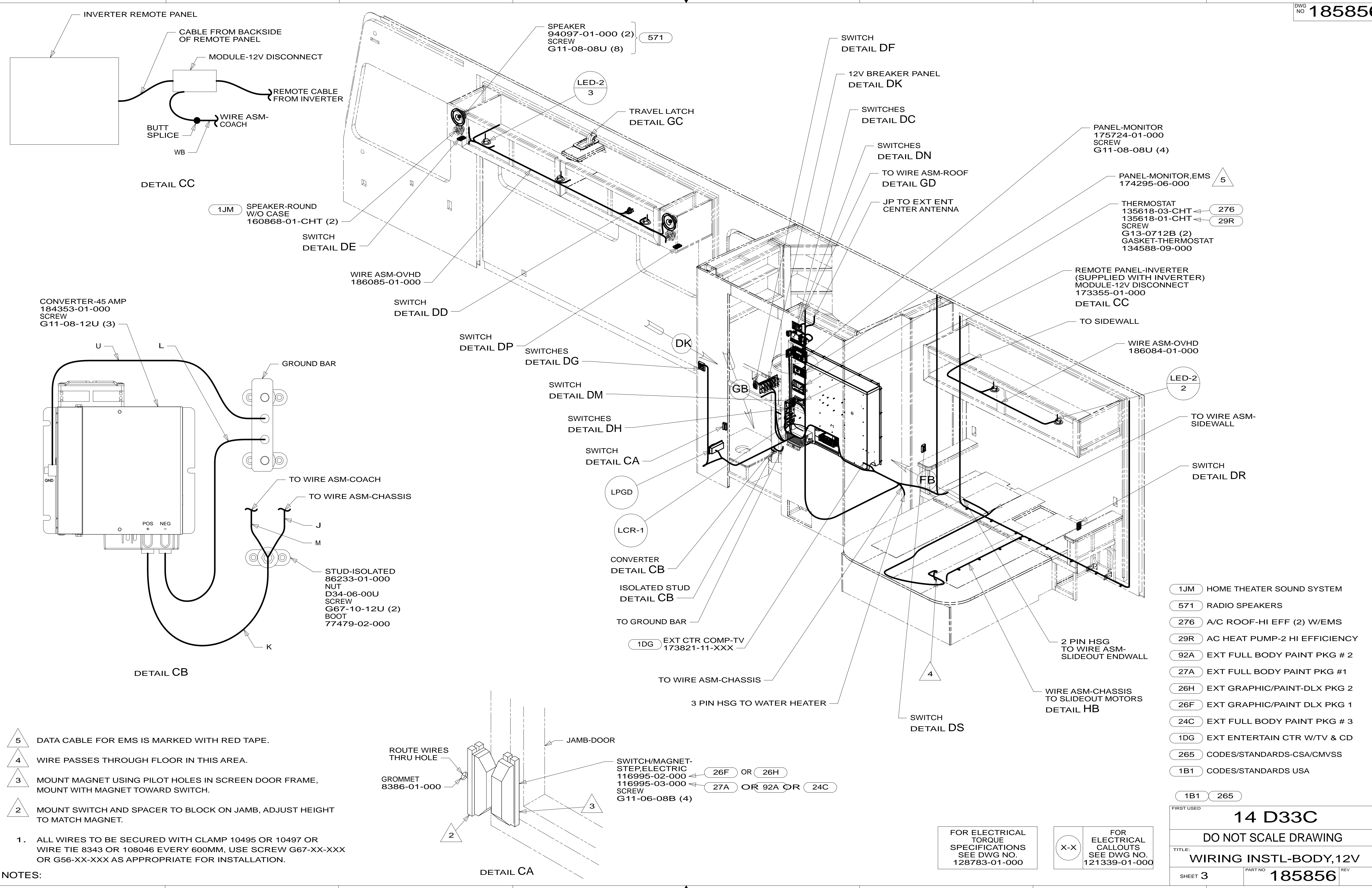

DETAIL CC

1JM SPEAKER-ROUND W/O CASE 160868-01-CHT (2)

SWITCH DETAIL DE

WIRE ASM-OVHD 186085-01-000

SWITCH DETAIL DD

SWITCH DETAIL DP SWITCHES DETAIL DG

SWITCH DETAIL DM

SWITCHES DETAIL DH

SWITCH DETAIL CA

LPGD

LCR-1

CONVERTER DETAIL CB

ISOLATED STUD DETAIL CB

TO GROUND BAR

1DG EXT CTR COMP-TV 173821-11-XXX

TO WIRE ASM-CHASSIS 3 PIN HSG TO WATER HEATER

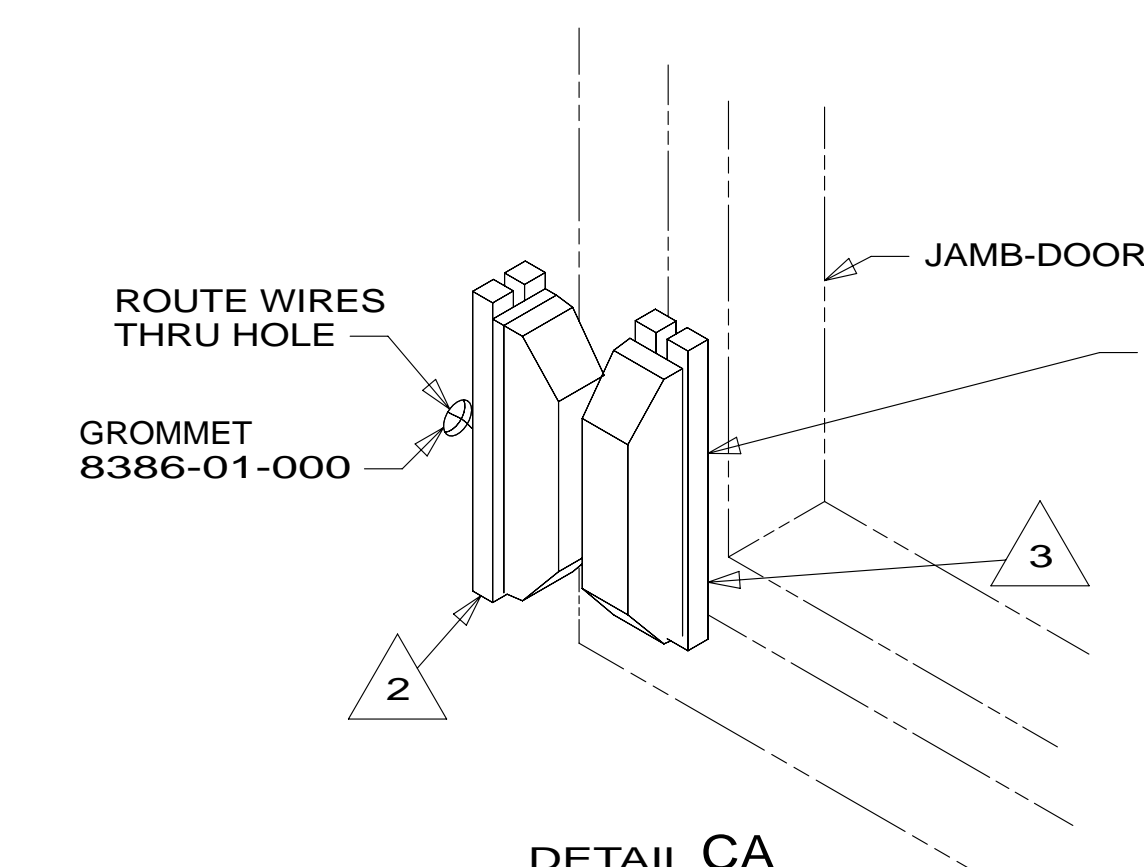

DETAIL CA

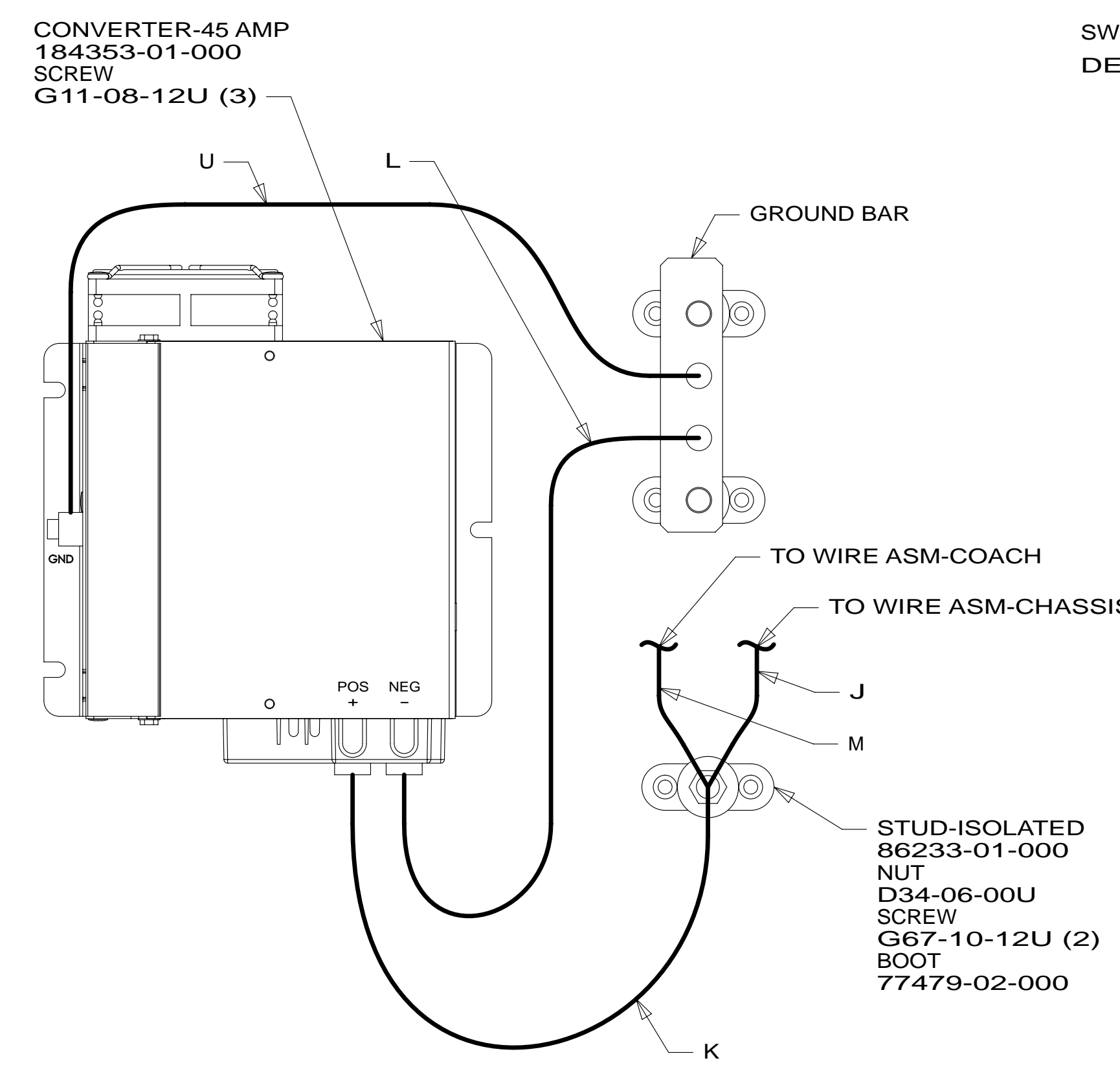

DETAIL CB

STUD-ISOLATED 86233-01-000 NUT D34-06-00U SCREW G67-10-12U (2) BOOT 77479-02-000

- 5 DATA CABLE FOR EMS IS MARKED WITH RED TAPE.
 - 4 WIRE PASSES THROUGH FLOOR IN THIS AREA.
 - 3 MOUNT MAGNET USING PILOT HOLES IN SCREEN DOOR FRAME, MOUNT WITH MAGNET TOWARD SWITCH.
 - 2 MOUNT SWITCH AND SPACER TO BLOCK ON JAMB, ADJUST HEIGHT TO MATCH MAGNET.
1. ALL WIRES TO BE SECURED WITH CLAMP 10495 OR 10497 OR WIRE TIE 8343 OR 108046 EVERY 600MM, USE SCREW G67-XX-XXX OR G56-XX-XXX AS APPROPRIATE FOR INSTALLATION.

NOTES:

- 1JM HOME THEATER SOUND SYSTEM
- 571 RADIO SPEAKERS
- 276 A/C ROOF-HI EFF (2) W/EMS
- 29R AC HEAT PUMP-2 HI EFFICIENCY
- 92A EXT FULL BODY PAINT PKG # 2
- 27A EXT FULL BODY PAINT PKG #1
- 26H EXT GRAPHIC/PAINT-DLX PKG 2
- 26F EXT GRAPHIC/PAINT DLX PKG 1
- 24C EXT FULL BODY PAINT PKG # 3
- 1DG EXT ENTERTAIN CTR W/TV & CD
- 265 CODES/STANDARDS-CSA/CMVSS
- 1B1 CODES/STANDARDS USA

| | |
|--------------------------------------|----------------------------|
| FIRST USED | |
| 14 D33C | |
| DO NOT SCALE DRAWING | |
| TITLE: WIRING INSTL-BODY, 12V | |
| SHEET 3 | PART NO. 185856 REV |

FOR ELECTRICAL TORQUE SPECIFICATIONS SEE DWG NO. 128783-01-000

FOR ELECTRICAL CALLOUTS SEE DWG NO. 121339-01-000

* 185856 A *

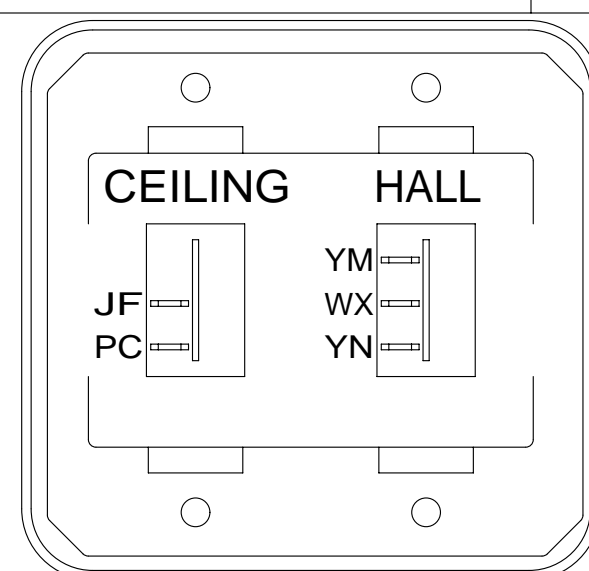

SWITCH-ROCKER 135740-01-CHT 135740-02-CHT SWITCH-BASE 135741-02-CHT SWITCH-BEZEL 135742-16-CHT SCREW G11-08-08U (4)

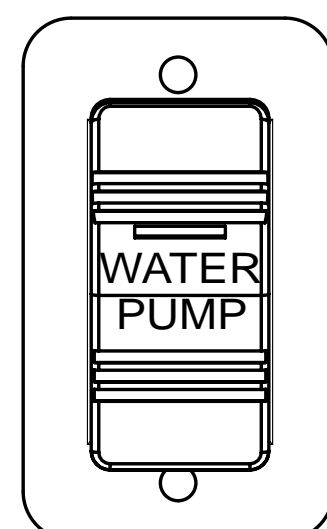

SWITCH-PUMP 108357-21-000 ACTUATOR 108356-23-CHT PLATE 98351-07-CHT SCREW G11-06-10U (2)

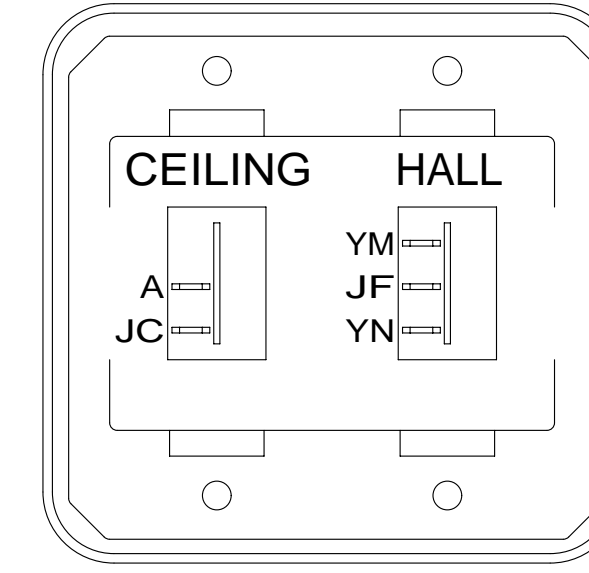

SWITCH-ROCKER 135740-01-CHT 135740-02-CHT SWITCH-BASE 135741-02-CHT SWITCH-BEZEL 135742-16-CHT SCREW G11-08-08U (4)

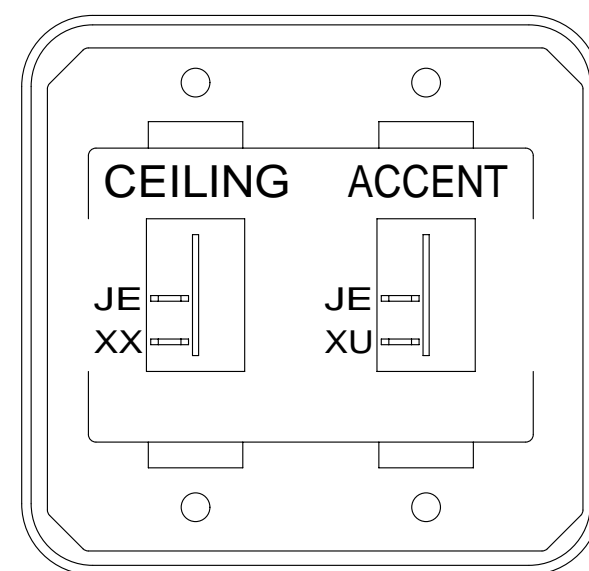

SWITCH-ROCKER 135740-01-CHT (2) SWITCH-BASE 135741-02-CHT SWITCH-BEZEL 135742-18-CHT SCREW G11-08-08U (4)

PLATE-SWITCH 158431-23-CHT SCREW G11-06-10U (6)

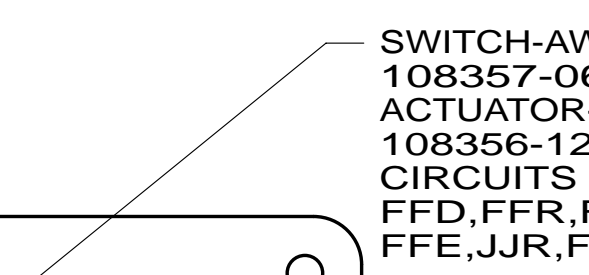

SWITCH-COMT LIGHTS 108357-01-000 ACTUATOR-SWITCH 108356-14-CHT CIRCUITS WC,NW

SWITCH-AWNING 108357-06-000 ACTUATOR-SWITCH 108356-12-CHT CIRCUITS FFD,FFR,FFE,FFE,JJR,FFD

SWITCH-AWNING 108357-14-000 ACTUATOR-SWITCH 108356-28-CHT CIRCUITS WC,WE,ZZK

SWITCH-AUTO LEVEL 108357-18-000 ACTUATOR-SWITCH 108356-15-CHT CIRCUITS SSD,SSE,SSC,SSE,SSF

SWITCH-STEP 108357-19-000 CIRCUITS ER,ES

SWITCH-CHASSIS BATTERY 108357-18-000 ACTUATOR-SWITCH 108356-20-CHT CIRCUITS TTY,TTZ,MK,UUB,UUC WIRE ASM-THERM 186796-01-000

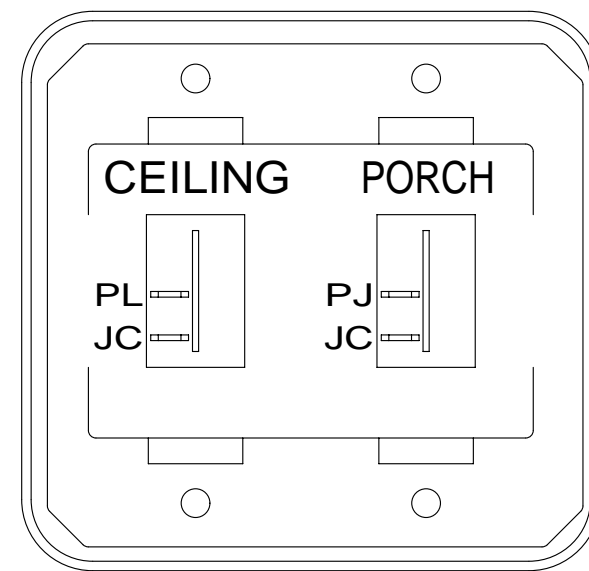

SWITCH-ROCKER 135740-01-CHT (2) SWITCH-BASE 135741-02-CHT SWITCH-BEZEL 135742-19-CHT SCREW G11-08-08U (4)

SWITCH-COACH BATT 108357-18-000 ACTUATOR-SWITCH 108356-19-CHT CIRCUITS KF,LJ,LG,LH,WC WIRE ASM-THERM 186796-01-000

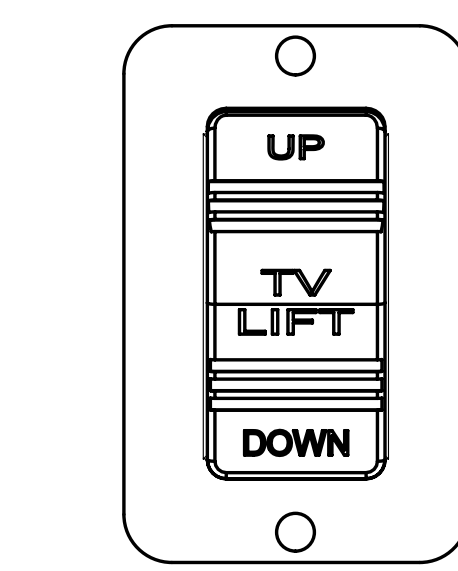

SWITCH-TV-LIFT 108357-16-000 ACTUATOR 108356-26-CHT PLATE 98351-07-CHT SCREW G11-06-10U (2)

DETAIL DD (2 PLACES) 21R

LABEL-SLIDEOUT,PASS,FRONT 163992-04-CHT

SLIDEOUT-ELEC,FRONT 171341-01-000 SCREW 76790-05-000 (2)

SWITCH 108357-06-000 ACTUATOR 108356-25-CHT PPP,PPV,PPN,PPN,PPU,PPP

CONNECT TO 12-PIN HOUSING WITH CIRCUITS SSN,NNP,NNR,NNN,HHE,HHF,WWR,WWP

LABEL-WARNING,SLIDEOUT 116549-01-000

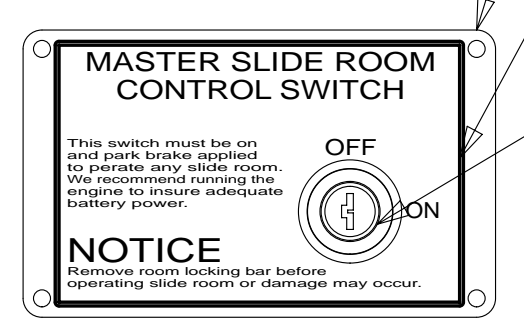

SWITCH-KEY,SPST-ILLINOIS LCK 163097-01-000 (CONNECTS TO CIRCUITS DY & DDJ)

LABEL-SLIDEOUT, DRIVER,FRONT 163988-01-CHT

LABEL-SLIDEOUT,PASS,REAR 163992-03-CHT

SWITCH 108357-06-000 ACTUATOR 108356-24-CHT (DR,DT,DU)

SWITCH 108357-06-000 ACTUATOR 108356-24-CHT (BBM,DT,BBN)

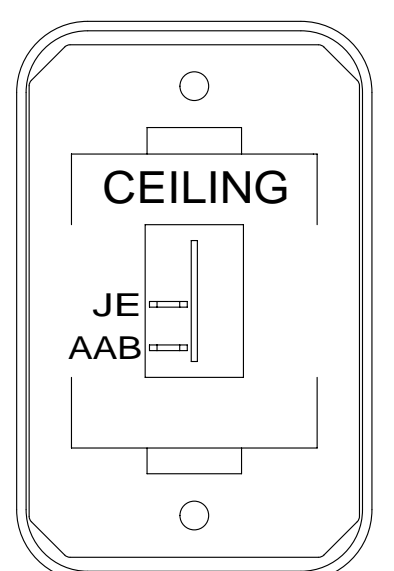

SWITCH-ROCKER 135740-01-CHT SWITCH-BASE 135741-01-CHT SWITCH-BEZEL 135742-07-CHT SCREW G11-08-08U (2)

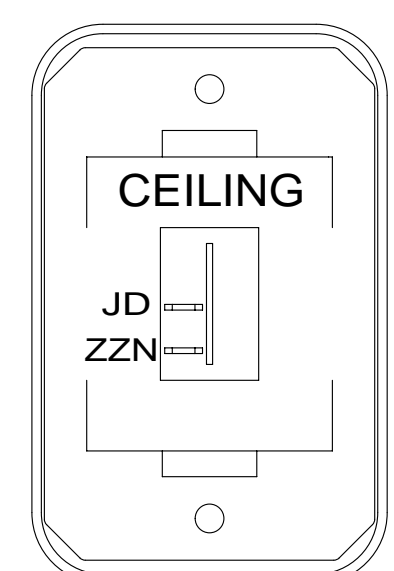

SWITCH-ROCKER 135740-01-CHT SWITCH-BASE 135741-01-CHT SWITCH-BEZEL 135742-07-CHT SCREW G11-08-08U (2)

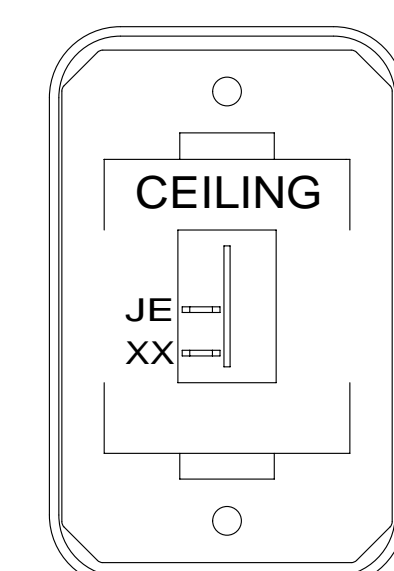

SWITCH-ROCKER 135740-01-CHT SWITCH-BASE 135741-01-CHT SWITCH-BEZEL 135742-07-CHT SCREW G11-08-08U (2)

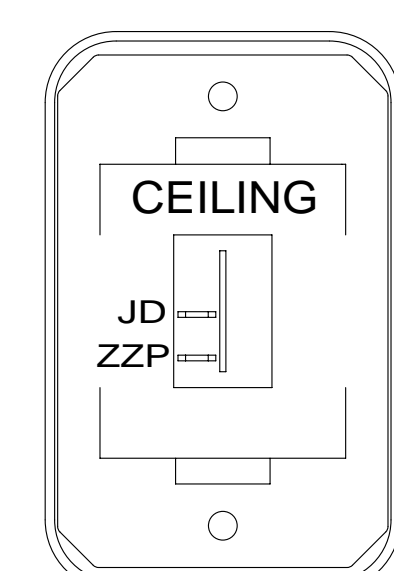

SWITCH-ROCKER 135740-01-CHT SWITCH-BASE 135741-01-CHT SWITCH-BEZEL 135742-07-CHT SCREW G11-08-08U (2)

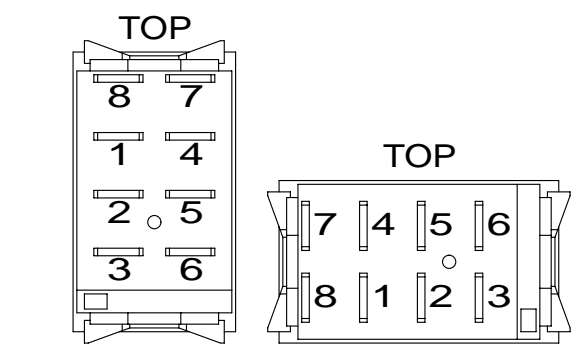

DETAIL DJ

41Z 41H

CIRCUIT BREAKER 93655-01-000 SCREW G52-06-04B WASHER OME02B

LABEL 92547-17-000

SCREW G11-10-12U (4)

SCREW G52-06-04B (12)

PLATE 139067-02-CHT

SCREW G39-08-06B (2)

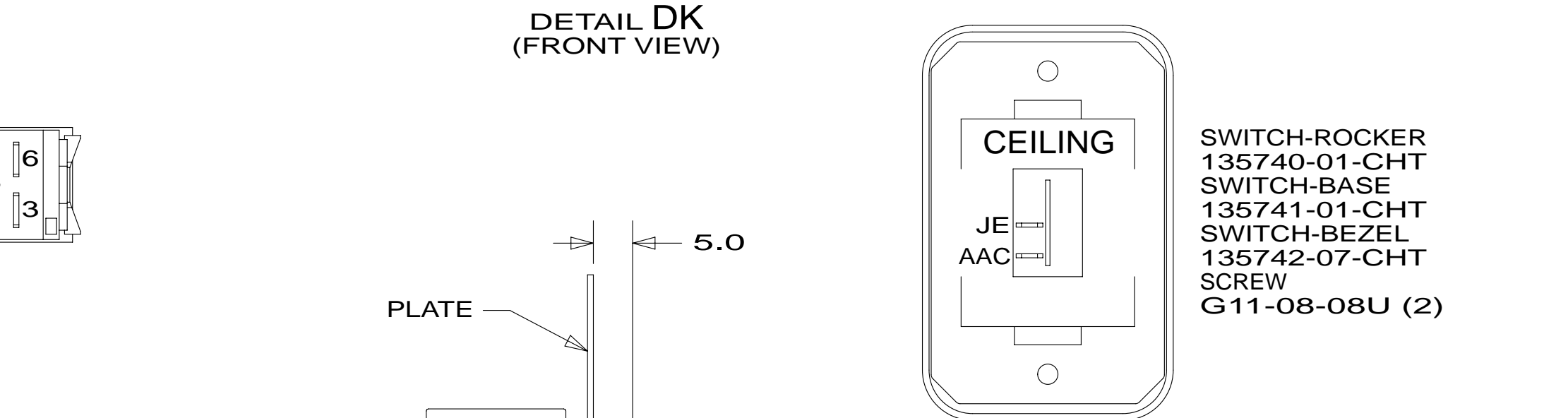
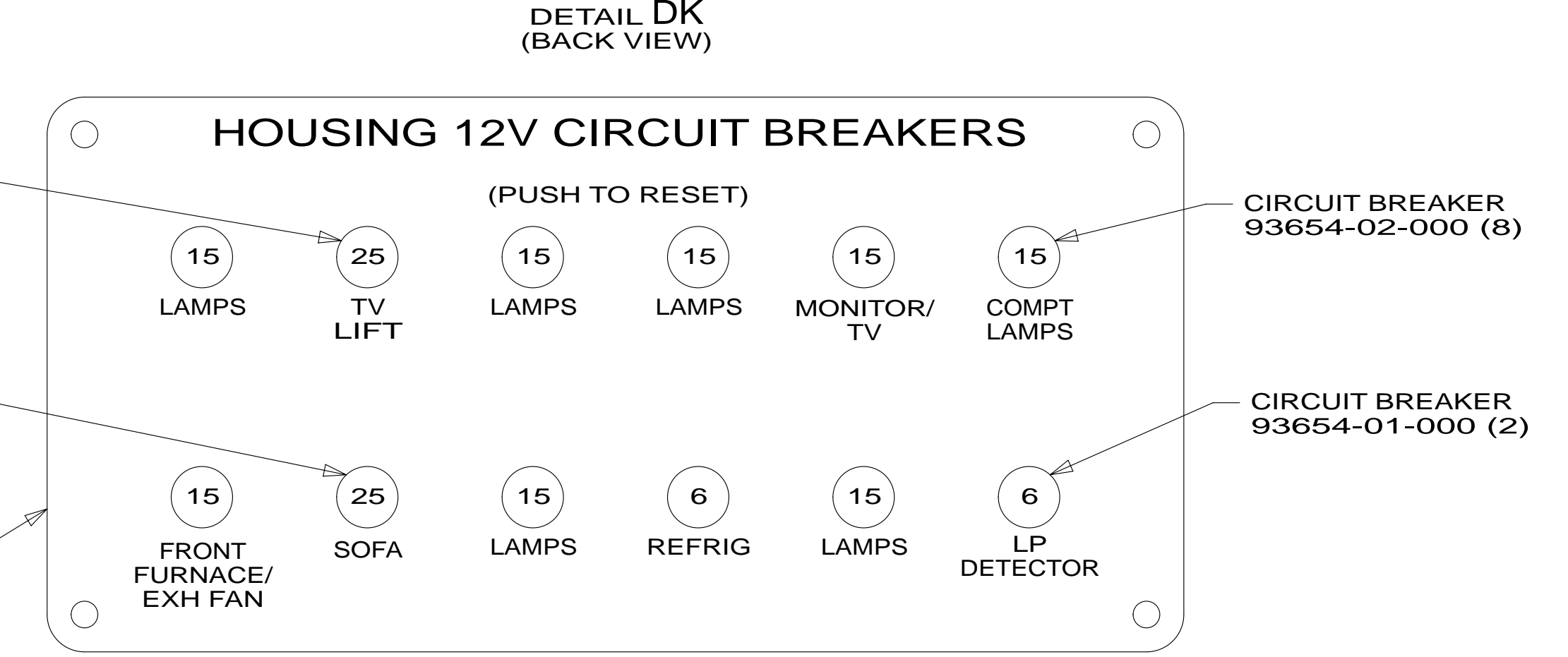
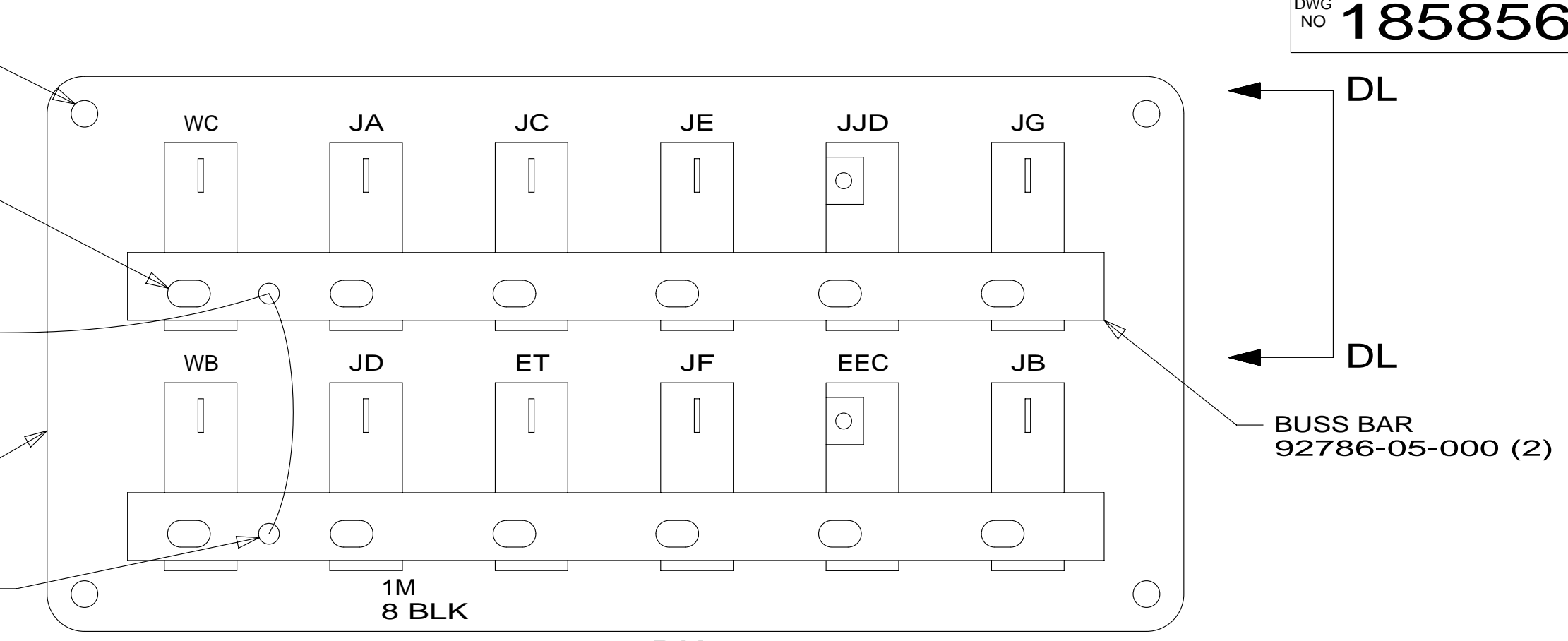

PLATE, BUSS BAR, HEX NUT-PALNUT (SUPPLIED WITH CIRCUIT BREAKER), KNURLED NUT (SUPPLIED WITH CIRCUIT BREAKER)

- 41Z RESTEASY DUAL CTL ULTRALE RH
- 41H REST EASY, ULTRALEATHER
- 21R DINING/BUFFET/POWERED TV
- 265 CODES/STANDARDS-CSA/CMVSS
- 1B1 CODES/STANDARDS USA

| | |
|------------------------------|----------------|
| FIRST USED | |
| 14 D33C | |
| DO NOT SCALE DRAWING | |
| TITLE: WIRING INSTL-BODY,12V | |
| SHEET 4 | PART NO 185856 |
| REV | |

FOR ELECTRICAL TORQUE SPECIFICATIONS SEE DWG NO. 128783-01-000

FOR ELECTRICAL CALLOUTS SEE DWG NO. 121339-01-000

NOTES: 1 FOR SWITCH ORIENTATION SEE DETAIL DJ.

* 185856

1JM 42K SPEAKER-ROUND, CEILING
179783-01-CHT (3)
SCREW
000G12-08-12U (12)

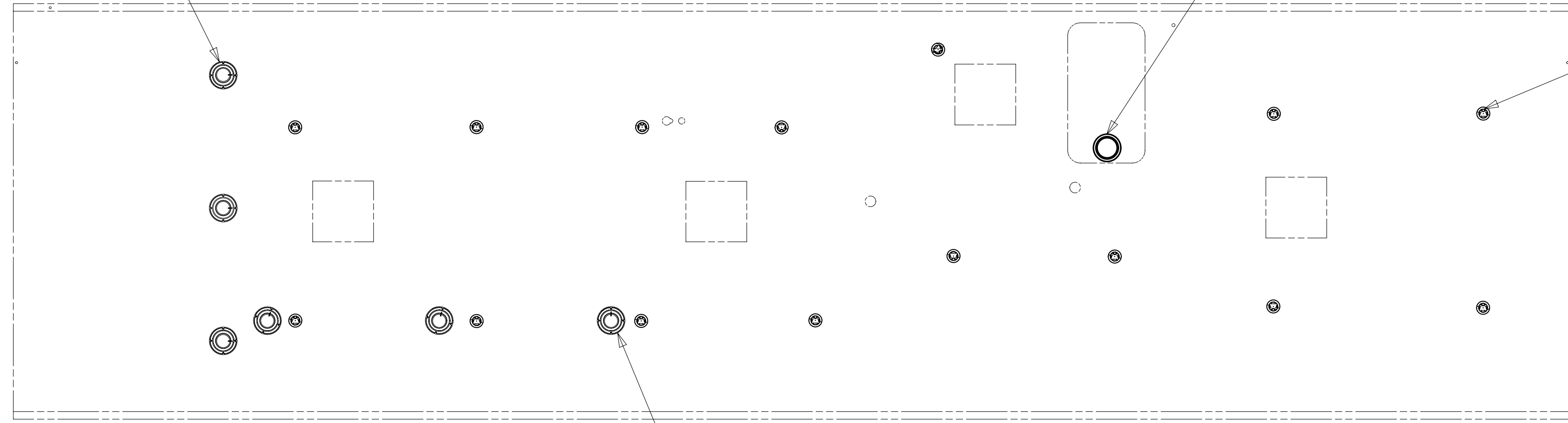

SPEAKER-ROUND, CEILING 1JM 21R
179783-01-CHT (3)
SCREW
G1208-12-170 (12)

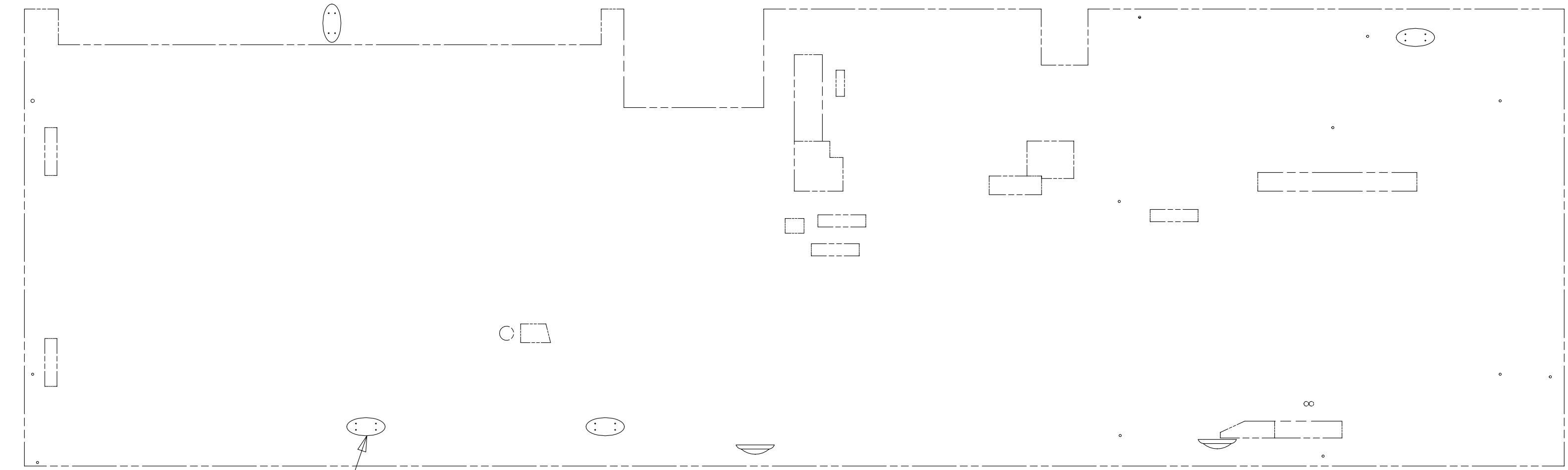

LO1-3 6 BULB-LED
176793-01-000 (6)
WASHER
180671-02-CHT (4) 2

- 42K TV-32" COLOR,STEREO W/REMOTE
- 21R DINING/BUFFET/POWERED TV
- 1JM HOME THEATER SOUND SYSTEM
- 265 CODES/STANDARDS-CSA/CMVSS
- 1B1 CODES/STANDARDS USA

1B1 265

FIRST USED 14 D33C

DO NOT SCALE DRAWING

TITLE: WIRING INSTL-BODY,12V

SHEET 5 PART NO 185856 REV

* 185856 *

2 REMOVE BULB SUPPLIED WITH LAMP, SEND BULB TO STOCK AS PART NUMBER 117805-02-000, REPLACE WITH LED BULB.

1 SENSOR SUPPLIED WITH SATELLITE ASSEMBLY.

NOTES:

FOR ELECTRICAL TORQUE SPECIFICATIONS SEE DWG NO. 128783-01-000

FOR ELECTRICAL CALLOUTS SEE DWG NO. 121339-01-000

THE SATELLITE DISH WIRE CONNECTIONS ARE TO BE PLACED ON THE CENTERLINE OF THE MOTORHOME FACING FORWARD

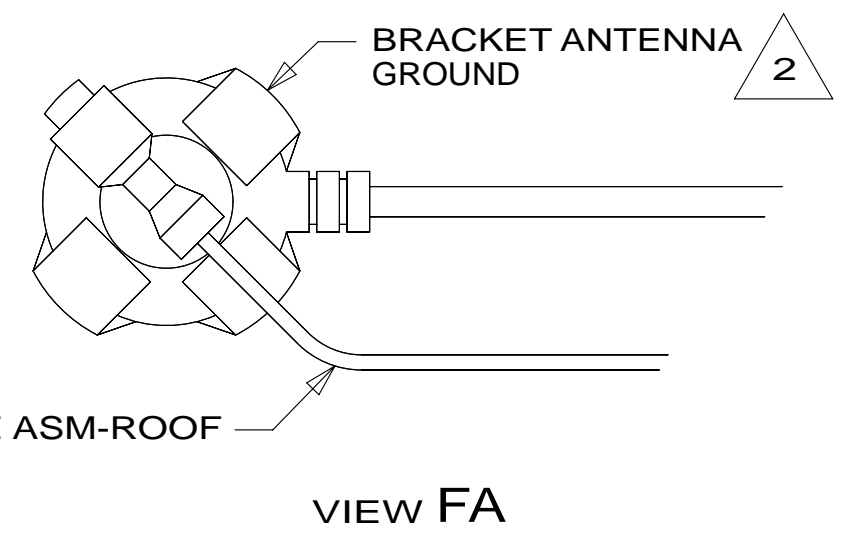
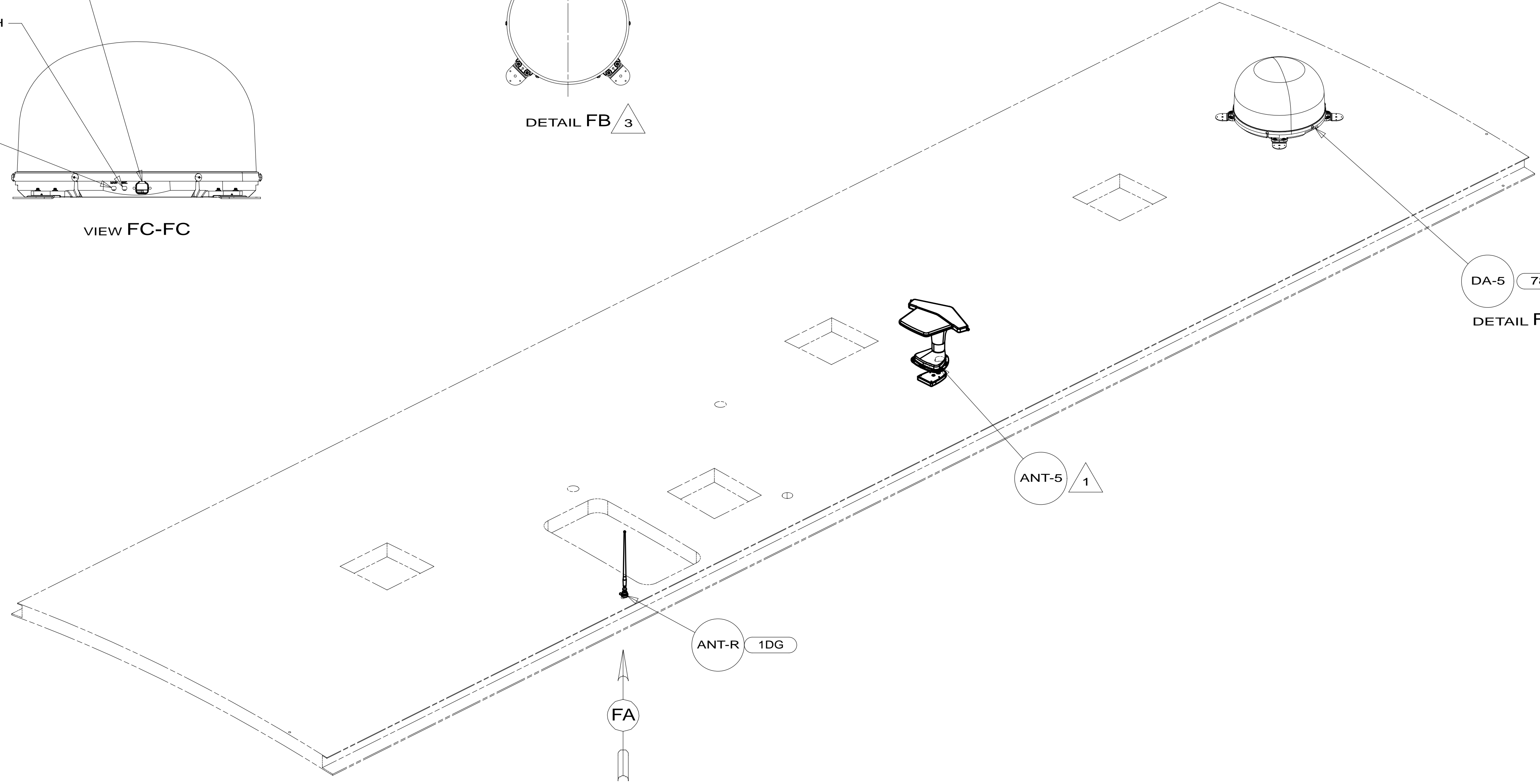
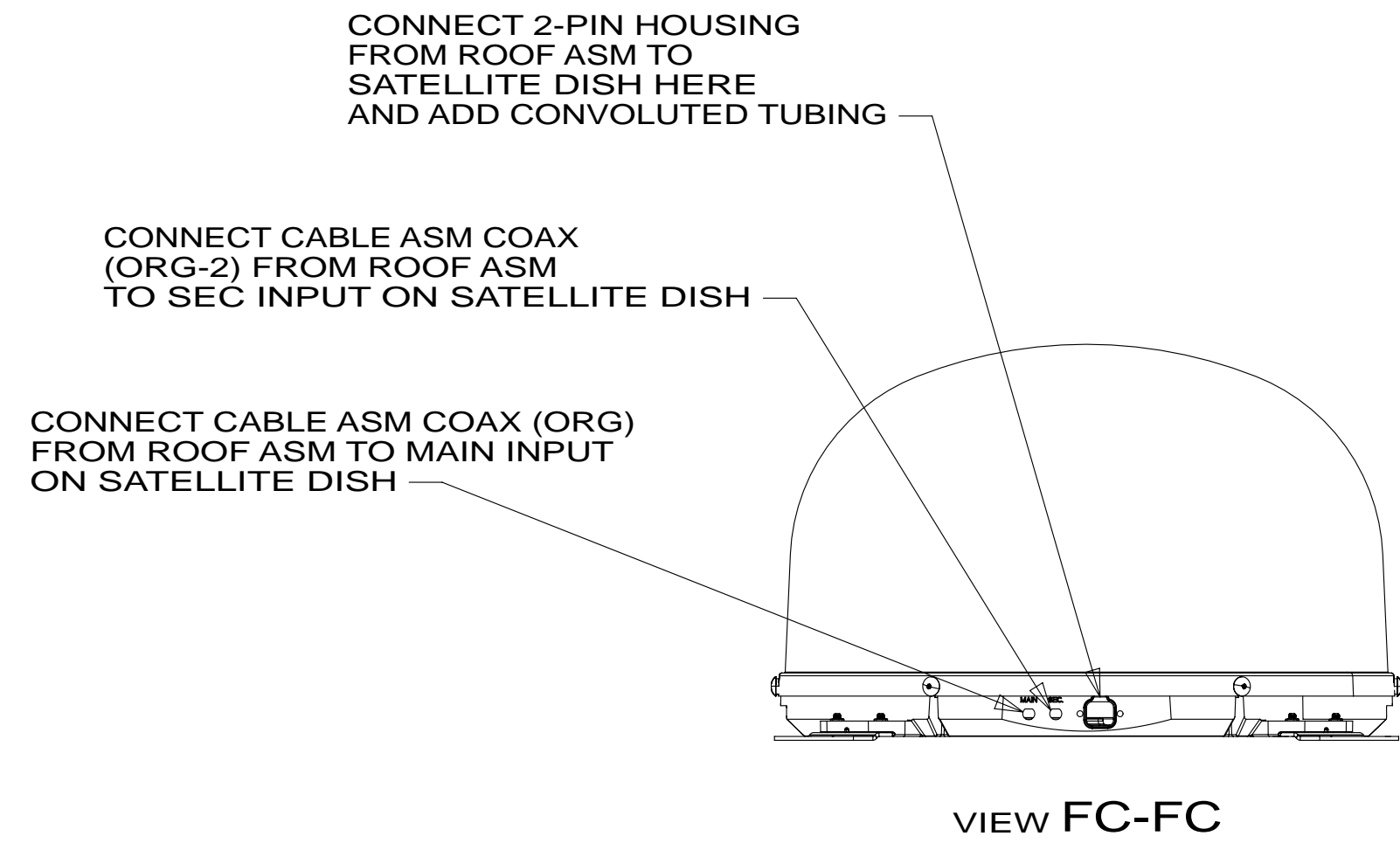
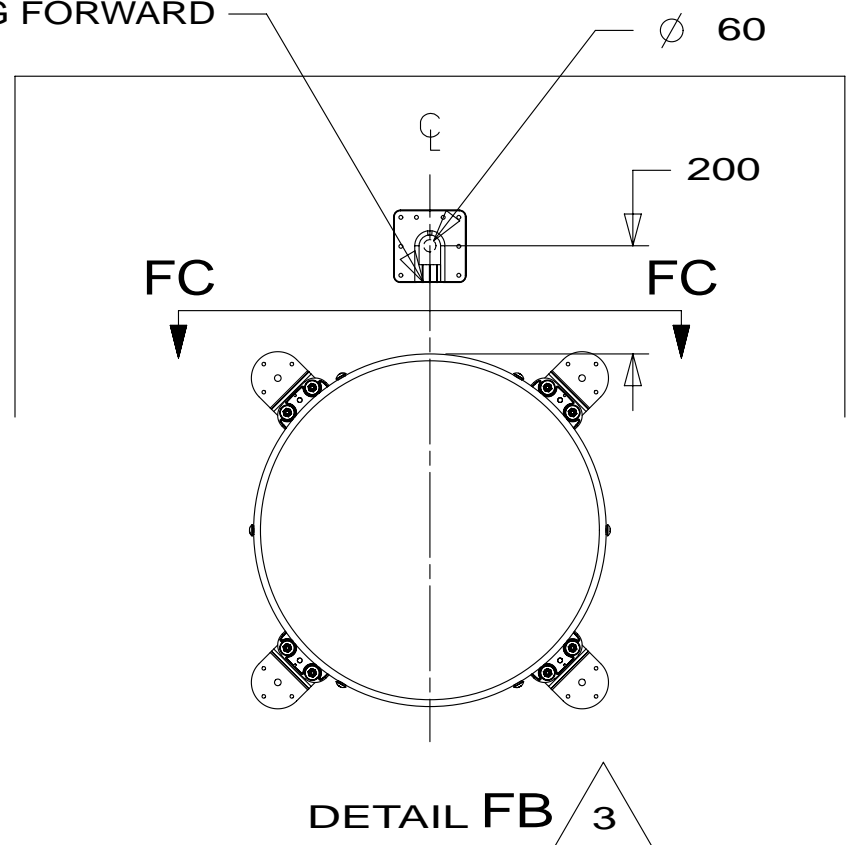

- NOTES:
- 3 SEE MANUFACTURER'S INSTALLATION FOR ADDITIONAL INFORMATION.
 - 2 WRAP LEGS AROUND ANTENNA BASE.
 - 1 SEE ANTENNA INSTALLATION MANUAL FOR CORRECT INSTALLATION PROCEDURE.

- 78K SATELLITE TV SYSTEM AUTO
- 1DG EXT ENTERTAIN CTR W/TV & CD
- 265 CODES/STANDARDS-CSA/CMVSS
- 1B1 CODES/STANDARDS USA

| | |
|--------------------------------------|---------------------------|
| FIRST USED | |
| 14 D33C | |
| DO NOT SCALE DRAWING | |
| TITLE: WIRING INSTL-BODY, 12V | |
| SHEET 6 | PART NO 185856 REV |
| 1 02-Jan-2014 | |

FOR ELECTRICAL TORQUE SPECIFICATIONS SEE DWG NO. 128783-01-000

FOR ELECTRICAL CALLOUTS SEE DWG NO. 121339-01-000

* 185856 *

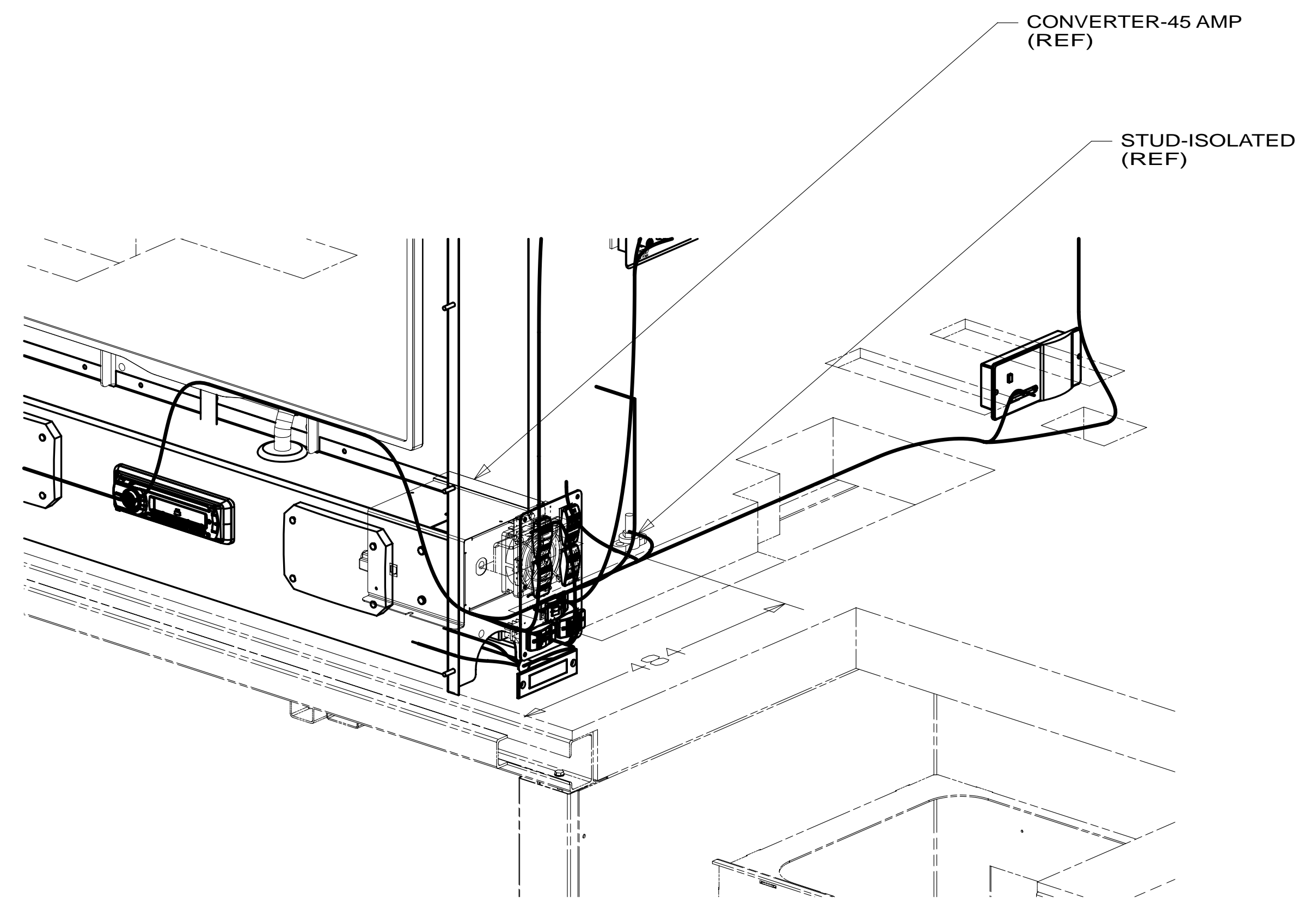

VIEW GB

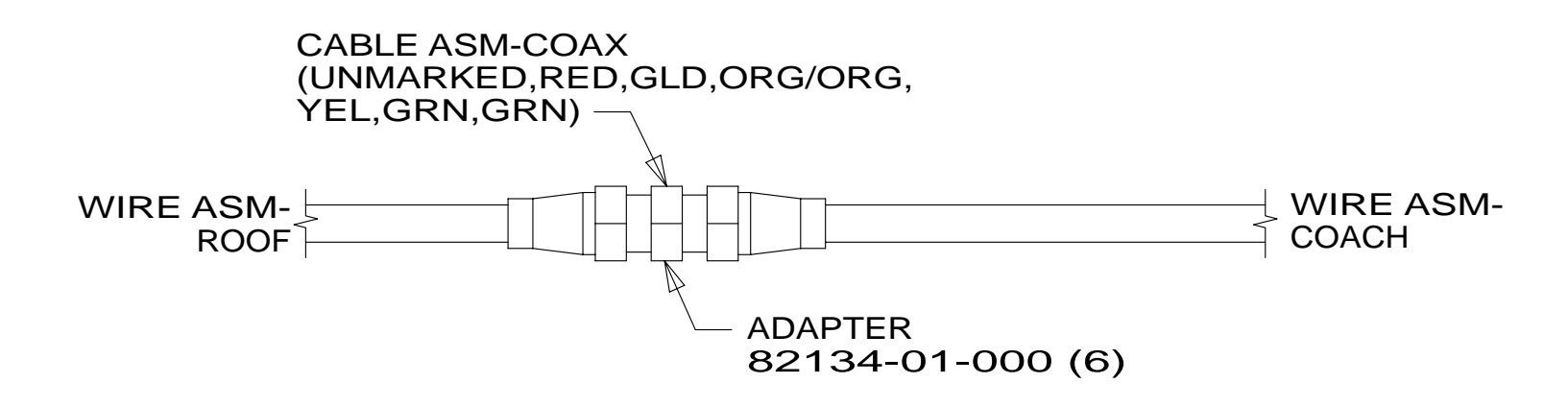
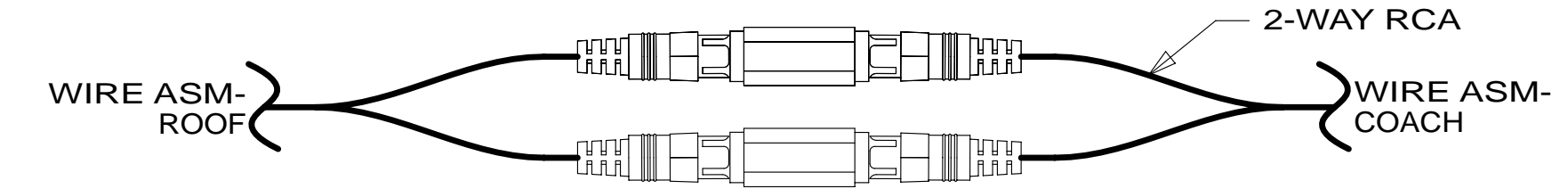
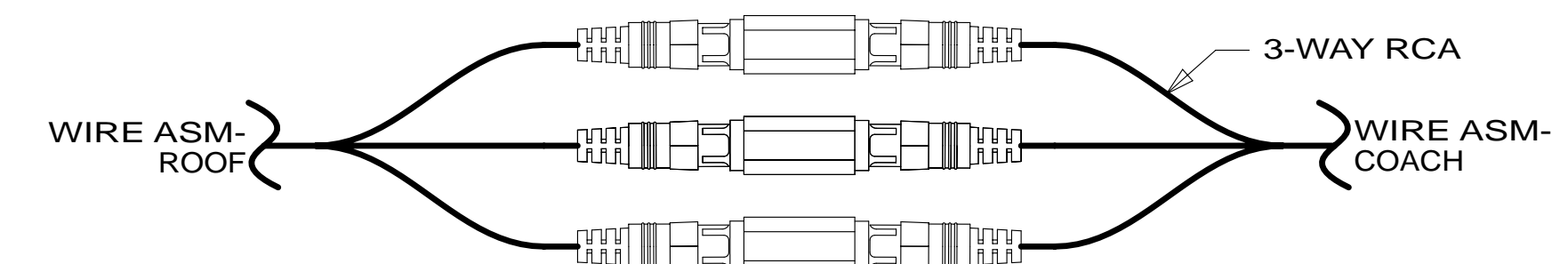
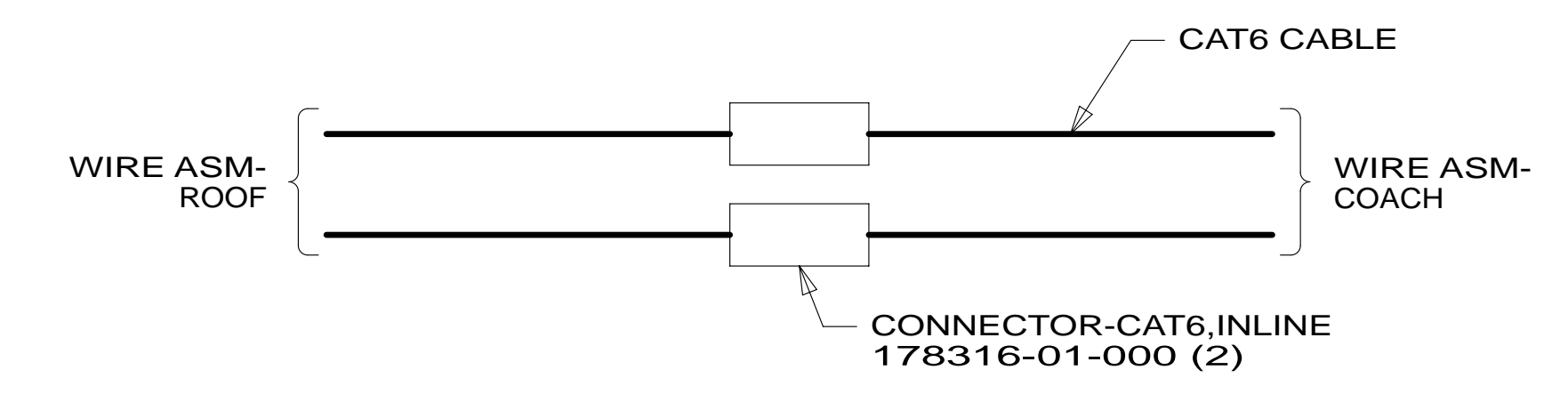
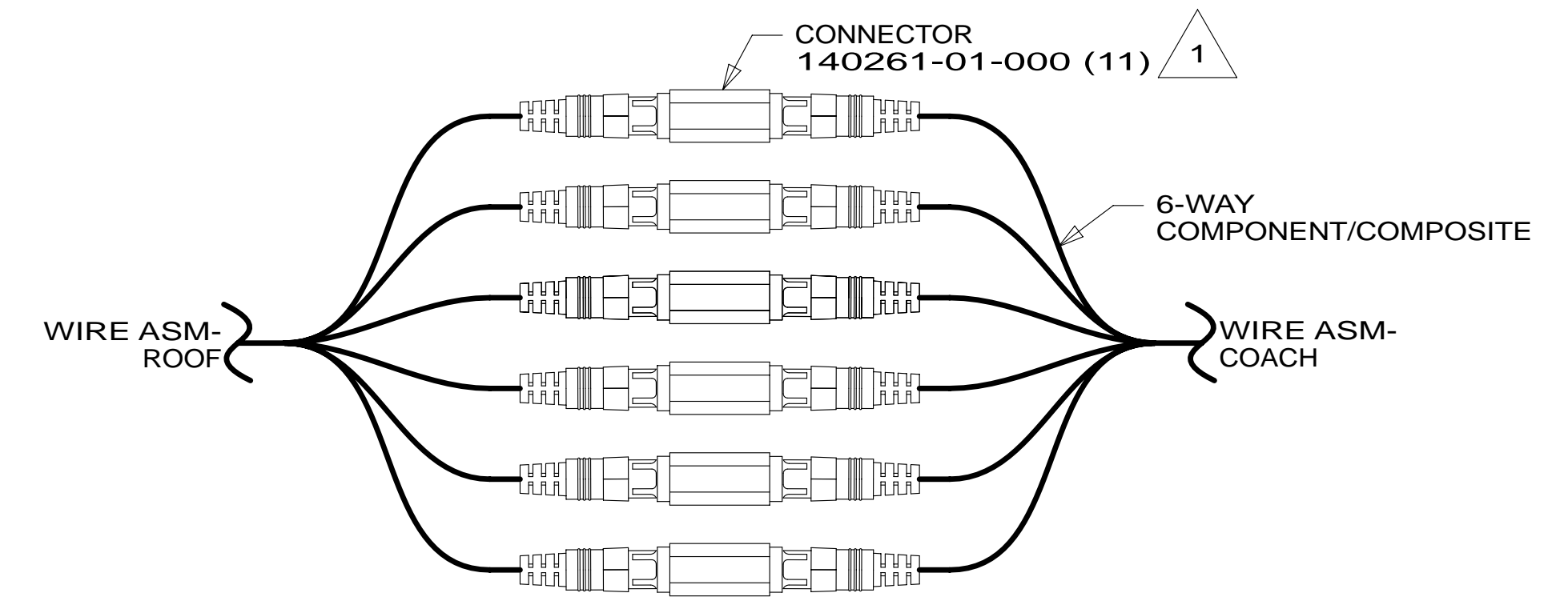

DETAIL GD

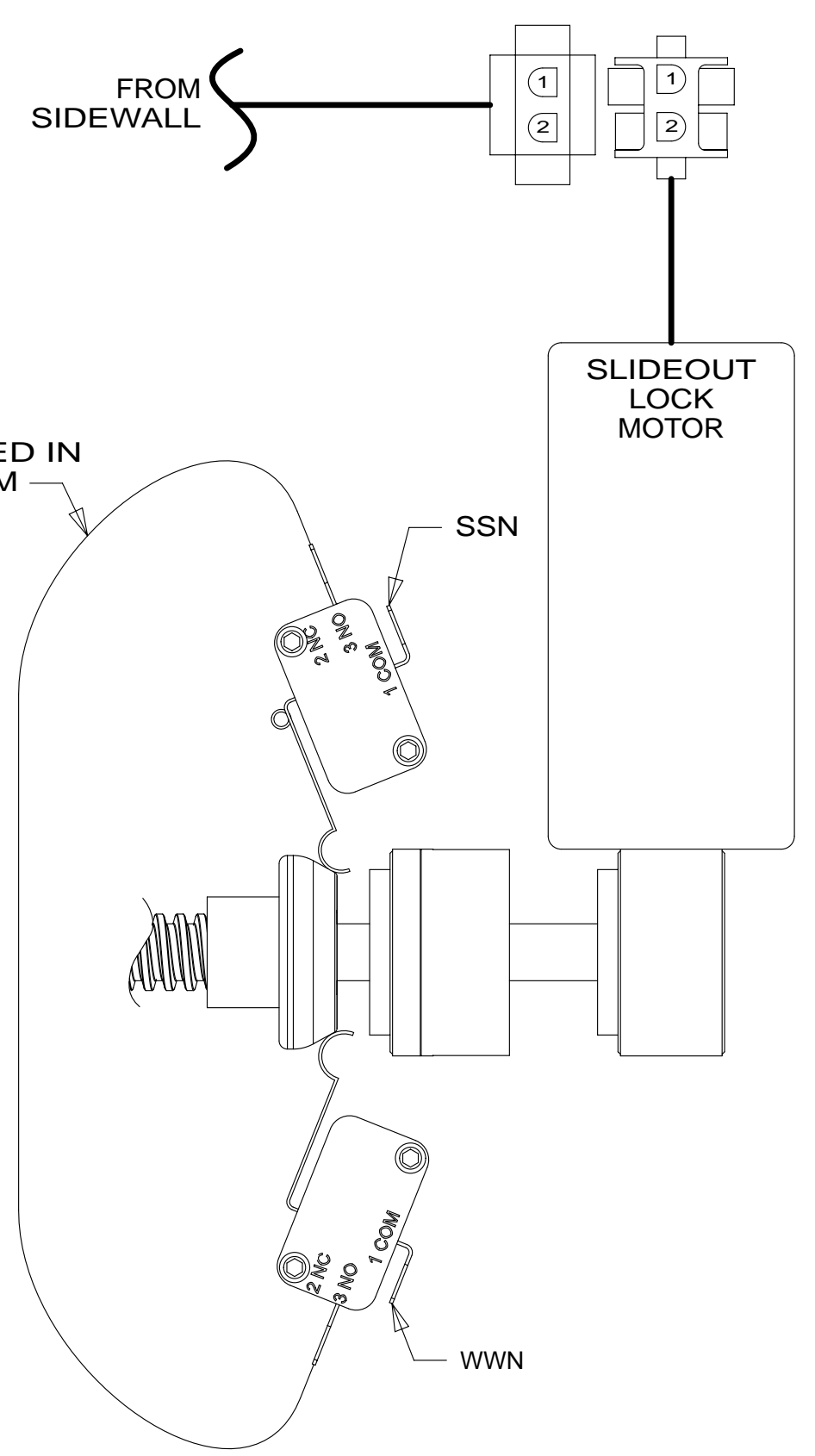

DETAIL GC (FRT RIGHT)

NOTES:

1 WRAP BOTH ENDS WITH TAPE 8363-01-000 TO SECURE CONNECTION.

FOR ELECTRICAL TORQUE SPECIFICATIONS SEE DWG NO. 128783-01-000

FOR ELECTRICAL SPECIFICATIONS SEE DWG NO. 121339-01-000

- 265 CODES/STANDARDS-CSA/CMVSS
- 1B1 CODES/STANDARDS USA
- 1B1 265

| | |
|--------------------------------------|----------------------------|
| FIRST USED | |
| 14 D33C | |
| DO NOT SCALE DRAWING | |
| TITLE: WIRING INSTL-BODY, 12V | |
| SHEET 7 | PART NO. 185856 REV |
| 02-Jan-2014 | |

* 185856 * A

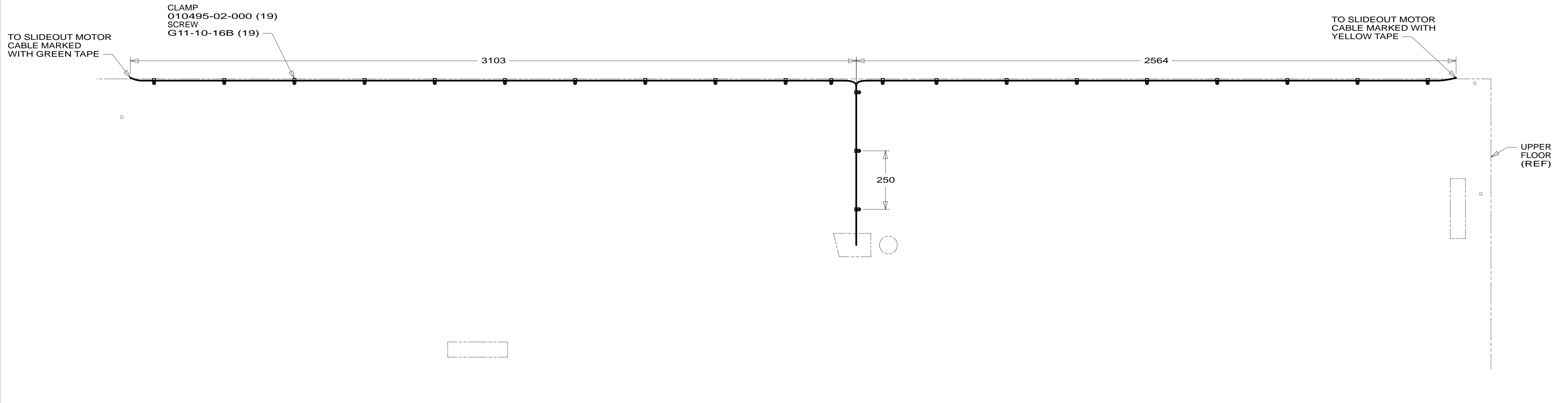

DETAIL HA (FRONT LEFT)

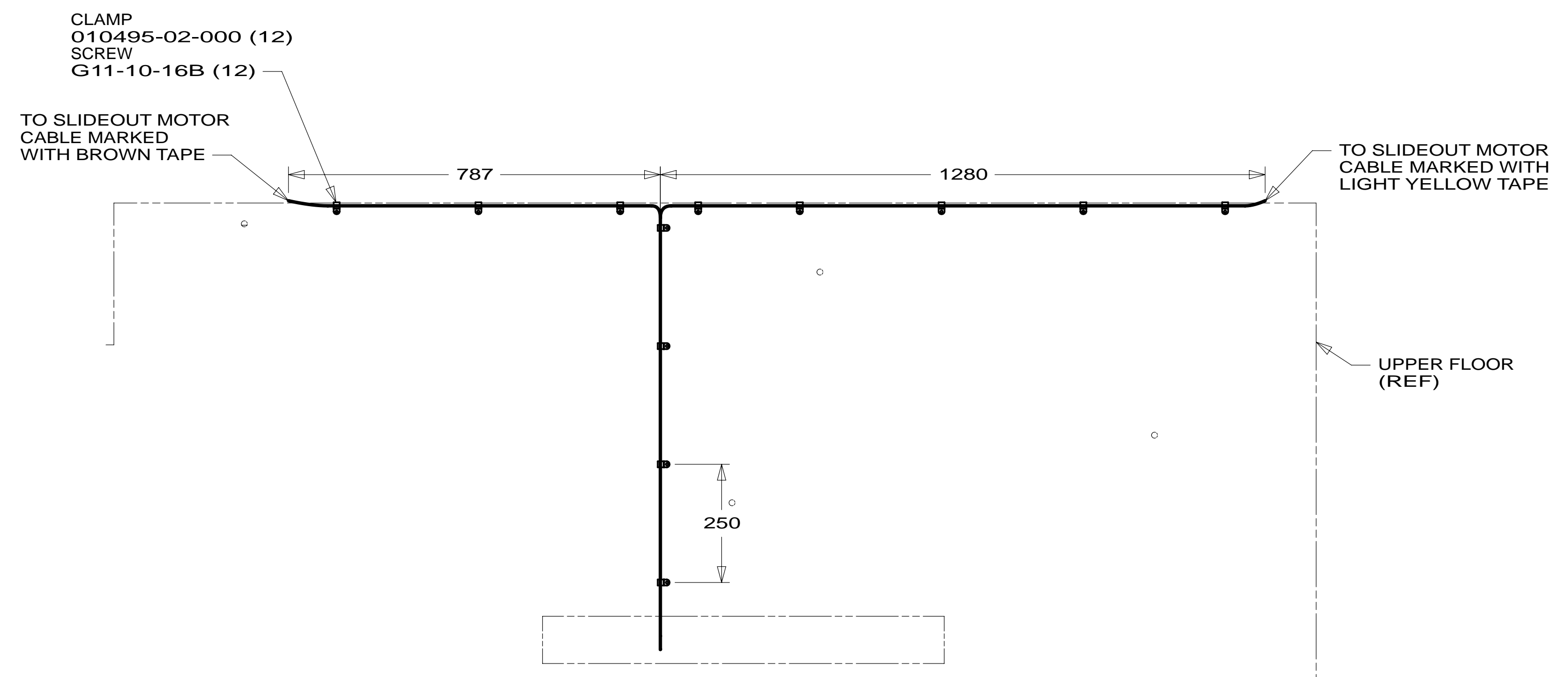

DETAIL HB (REAR RIGHT)

265 CODES/STANDARDS-CSA/CMVSS

1B1 CODES/STANDARDS USA

1B1 265

FIRST USED 14 D33C

DO NOT SCALE DRAWING

TITLE: WIRING INSTL-BODY, 12V

SHEET 8 PART NO 185856 REV

FOR ELECTRICAL TORQUE SPECIFICATIONS SEE DWG NO. 128783-01-000

FOR ELECTRICAL CALLOUTS SEE DWG NO. 121339-01-000

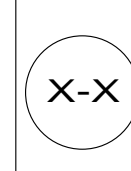

* 185856 * A