



DANGER

Danger of electrical shock, burns or death. Always remove all power sources before attempting any repair, service or diagnostic work. Power can be present from shore power, generator, inverter or battery. All power sources must be disabled and secured before performing any service.



CAUTION

If you lack the skills, tools or equipment to perform diagnostic or repair work leave such work to an authorized Winnebago Industries dealer or other qualified shop.

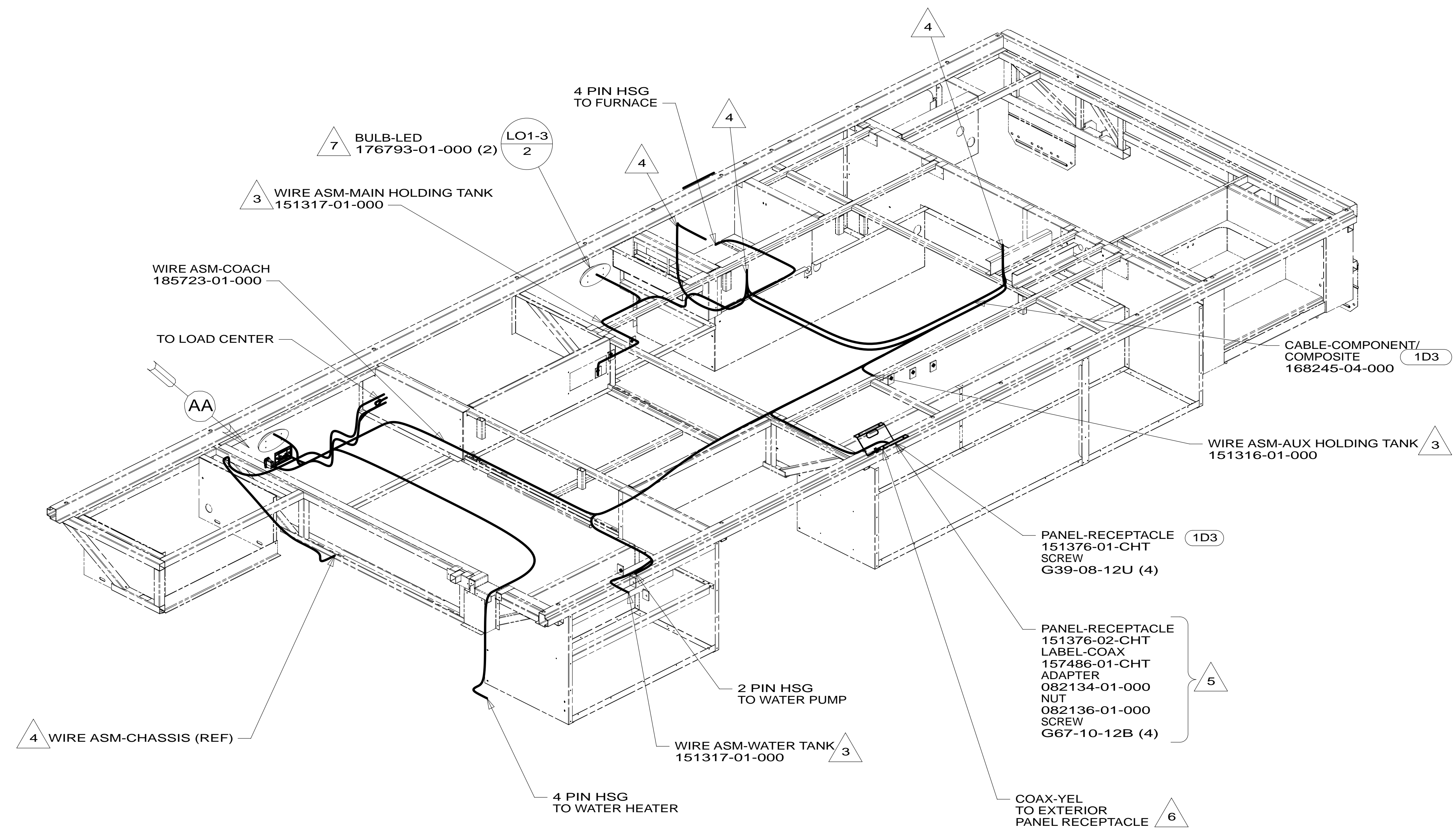

- 1D3 ENTERTAIN CENTR/EXT TV-DVD
- 401 INVERTER-DC/AC, 1000 WATT
- 265 CODES/STANDARDS-CSA/CMVSS
- 1B1 CODES/STANDARDS USA

1B1 265

WINNEBAGO COPYRIGHT 2013 WINNEBAGO INDUSTRIES, INC.

DFTR	ORIG. DATE
CHKR	ALL DIMENSIONS ARE IN MILLIMETERS
P.E.	FIRST USED
M.E.	14 E27N
DSNR	MATERIAL:
UNSPECIFIED TOLERANCES ARE:	
WHOLE DIM (X)	: 3
ONE-PLACE (X.X)	: 1.5
TWO-PLACE (X.XX)	: 0.50
ANGLE	: 1°
THIRD ANGLE PROJECTION	
DO NOT SCALE DRAWING	REFER TO ES0018 FOR FASTENER TIGHTENING GUIDELINES
TITLE: WIRING INSTL-BODY, 12V	
SHEET 1 OF 6	PART NO 185721 REV
REF:	1 19-Dec-2013

- 7 REMOVE BULB SUPPLIED WITH LAMP, SEND BULB TO STOCK AS PART NUMBER 117805-02-000, REPLACE WITH LED BULB.
 - 6 WITH 1D3 ROUTE YELLOW COAX TO SLIDEOUT WITH WIRE ASM-COACH.
 - 5 NOT USED WITH 1D3
 - 4 WIRE PASSES THROUGH FLOOR IN THIS AREA.
 - 3 PLACE CROSS LOCATOR ON SENSORS OVER DIMPLES ON TANK.
2. ROUTE TANK SENSOR WIRES SO THEY DO NOT PASS OVER SENSORS. USE WIRE TIE MOUNT 155366-01-000 AND WIRE TIE 8343-01-000 AS NEEDED. TANK SURFACE MUST BE CLEANED USING ISOPROPYL ALCOHOL AND PRIMED WITH PRIMER 94.
 1. AT MINIMUM ALL WIRES TO BE SUPPORTED AND SECURED PER CODE REQUIREMENTS. USE CLAMP 10495 OR 10497 OR WIRE TIE 8343 OR 108046 AND SCREW G67-XX-XXX OR G56-XX-XXX AS APPROPRIATE FOR INSTALLATION.

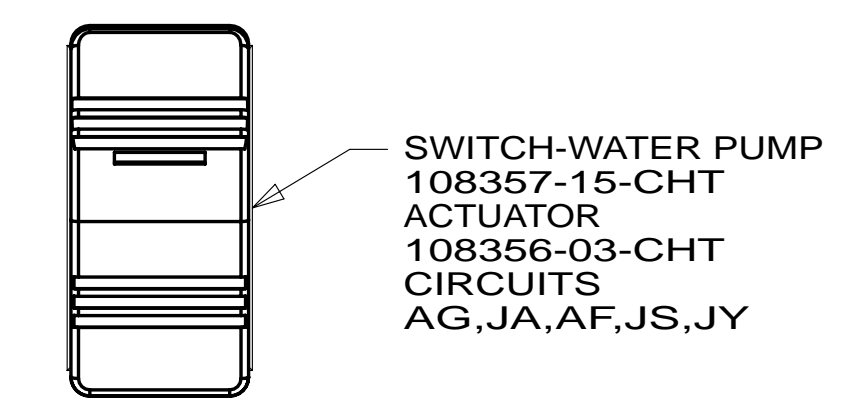
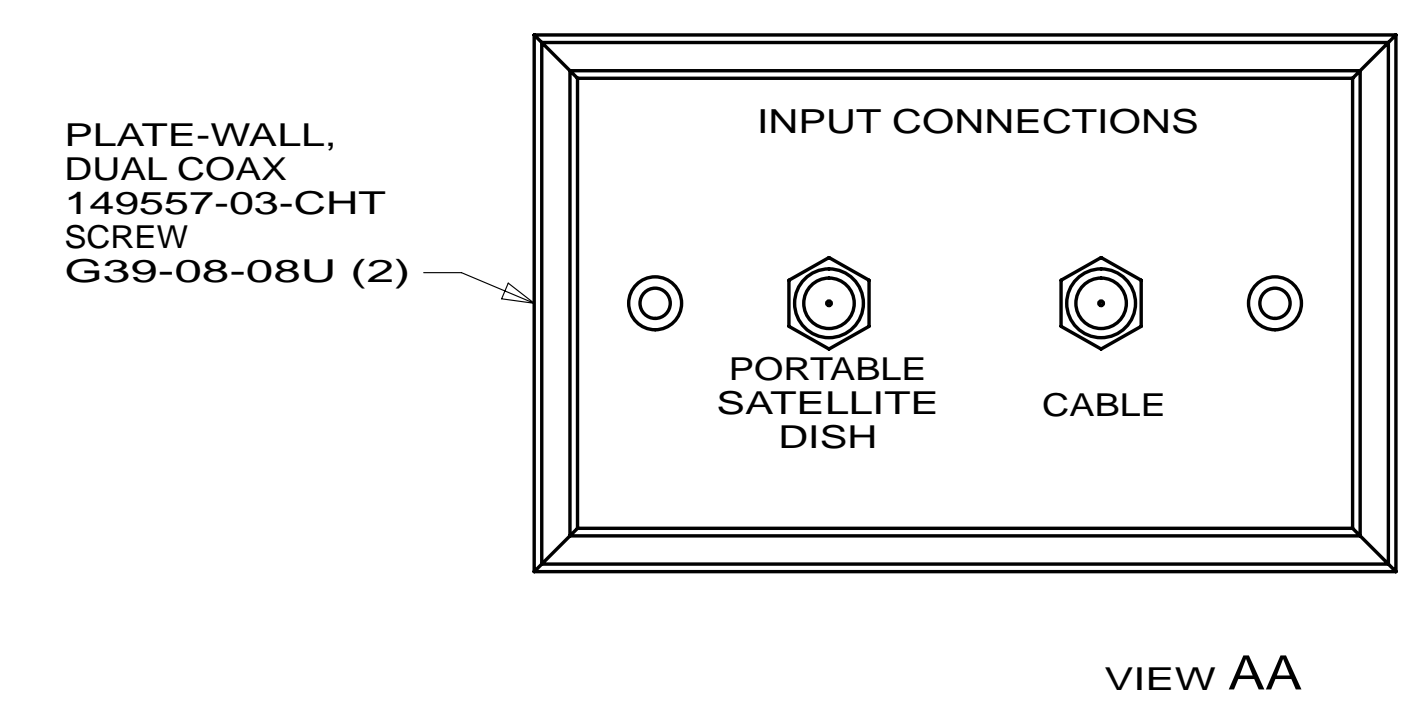

FOR ELECTRICAL TORQUE SPECIFICATIONS SEE DWG NO. 128783-01-000

FOR ELECTRICAL CALLOUTS SEE DWG NO. 121339-01-000

* 185721 *

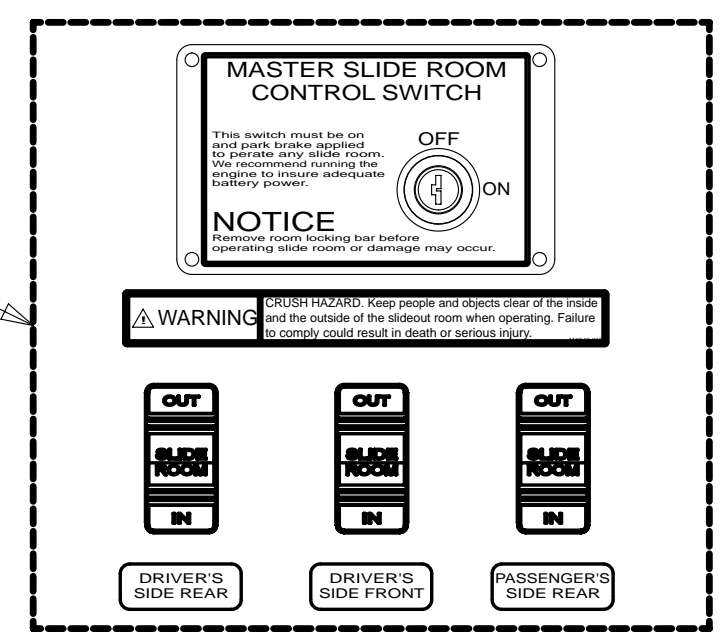

SWITCHES
DETAIL DG

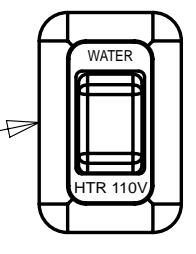

SWITCH
DETAIL DF

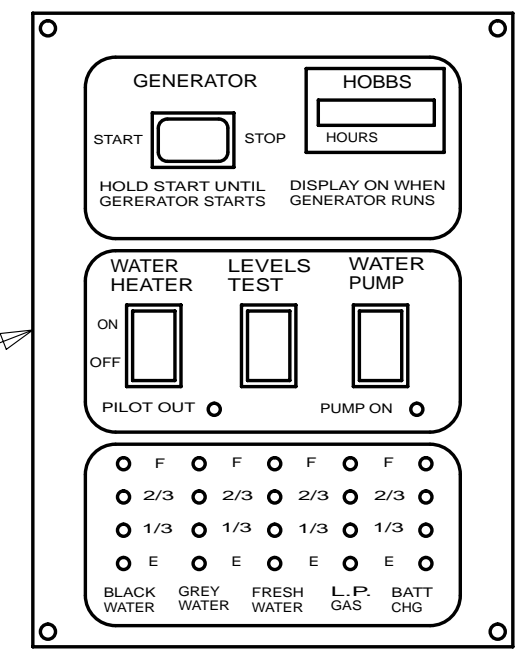

PANEL-MONITOR
134940-06-CHT
SCREW
G11-08-08U (4)

THERMOSTAT
25Q 135618-03-CHT
OR
29J 135618-01-CHT
SCREW
G13-07-12U (2)

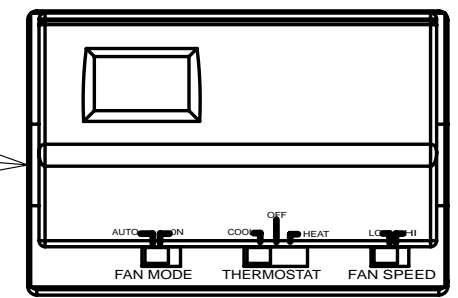

401 REMOTE PANEL-INVERTER
(SUPPLIED W/INVERTER)
MODULE-12V DISCONNECT
173355-01-000
DETAIL BC

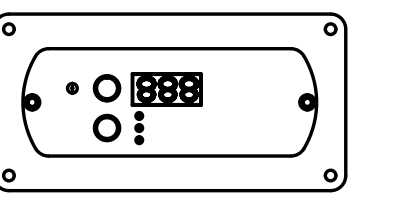

DETAIL BB

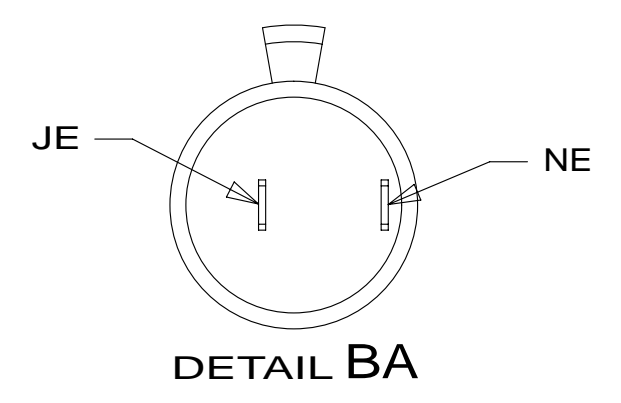

DETAIL BA

41Q WIRE ASM-OVHD
133574-01-000
22L OR 14W 133572-01-015

TO WIRE ASM-ROOF
DETAIL FA

41Q READ-1
2

TO REAR SLIDEOUT MOTOR

TO WIRE ASM-SLIDEOUT

MAIN TV CONNECTORS
FROM ROOF

3 68D TV-40"
(REF)

RECEPTACLE-12V
132958-01-000
DETAIL BA

TO FRONT
SLIDEOUT MOTOR

TO REAR SLIDEOUT MOTOR

6-PIN HSG
TO WIRE ASM-ROOF

WIRE ASM-OVHD
182761-01-000

SPEAKER
94097-01-000 (2)
GRILLE
173348-01-CHT (2)
SCREW
G11-08-08U (8)

4 BULB-LED
176793-01-000(2)
LO1-3
2

2 HOUSINGS TO
SLIDEOUT MOTORS

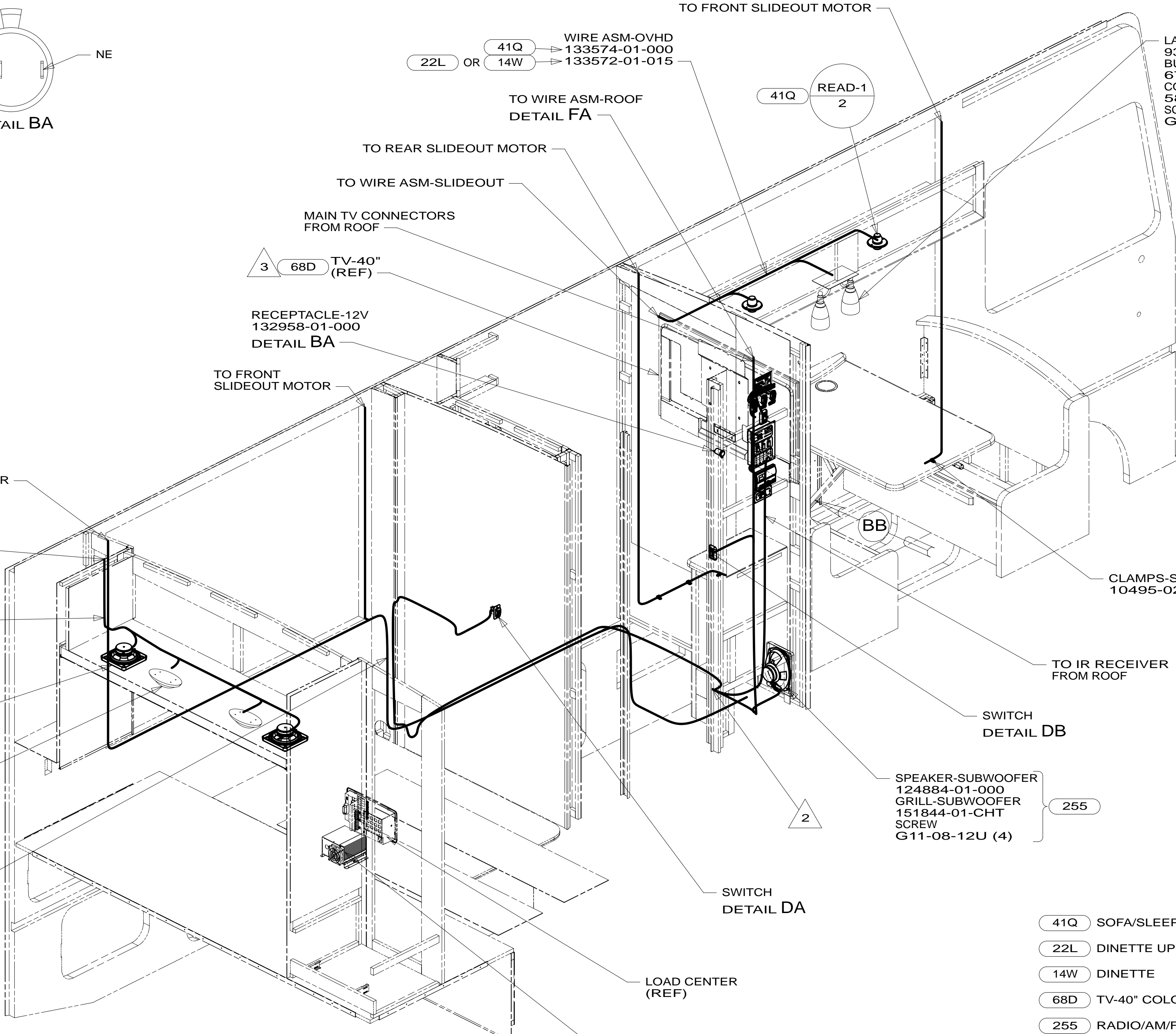

LAMP
93575-62-CHT
BULB
67479-01-000 (2)
CONNECTOR
58028-01-000 (2)
SCREW
G11-06-10U (2)

22L OR 14W

CLAMPS-SLIDEOUT WIRES
10495-02-000 (4)

TO IR RECEIVER
FROM ROOF

SWITCH
DETAIL DB

SPEAKER-SUBWOOFER
124884-01-000
GRILL-SUBWOOFER
151844-01-CHT
SCREW
G11-08-12U (4)

255

SWITCH
DETAIL DA

LOAD CENTER
(REF)

CONVERTER-45 AMP
184353-01-000
SCREW
G11-08-12U (3)

- 41Q SOFA/SLEEPER-ULTRALEATHER
- 22L DINETTE UPGRADE
- 14W DINETTE
- 68D TV-40" COLOR,STEREO W/REMOTE
- 255 RADIO/AM/FM/CD/DVD PLAYER
- 401 INVERTER-DC/AC, 1000 WATT
- 29J AC HEAT PUMP-1
- 25Q A/C ROOF AIR (1) 14,800 BTU
- 265 CODES/STANDARDS-CSA/CMVSS
- 1B1 CODES/STANDARDS USA

1B1 265

- 4 REMOVE BULB SUPPLIED WITH LAMP, SEND BULB TO STOCK AS PART NUMBER 117805-02-000, REPLACE WITH LED BULB.
- 3 SEE WIRING INSTL-TV/DVD FOR ADDITIONAL INFORMATION.
- 2 WIRE PASSES THROUGH FLOOR IN THIS AREA.

1. AT MINIMUM ALL WIRES TO BE SUPPORTED AND SECURED PER CODE REQUIREMENTS. USE CLAMP 10495 OR 10497 OR WIRE TIE 8343 OR 108046 AND SCREW G67-XX-XXX OR G56-XX-XXX AS APPROPRIATE FOR INSTALLATION.

NOTES:

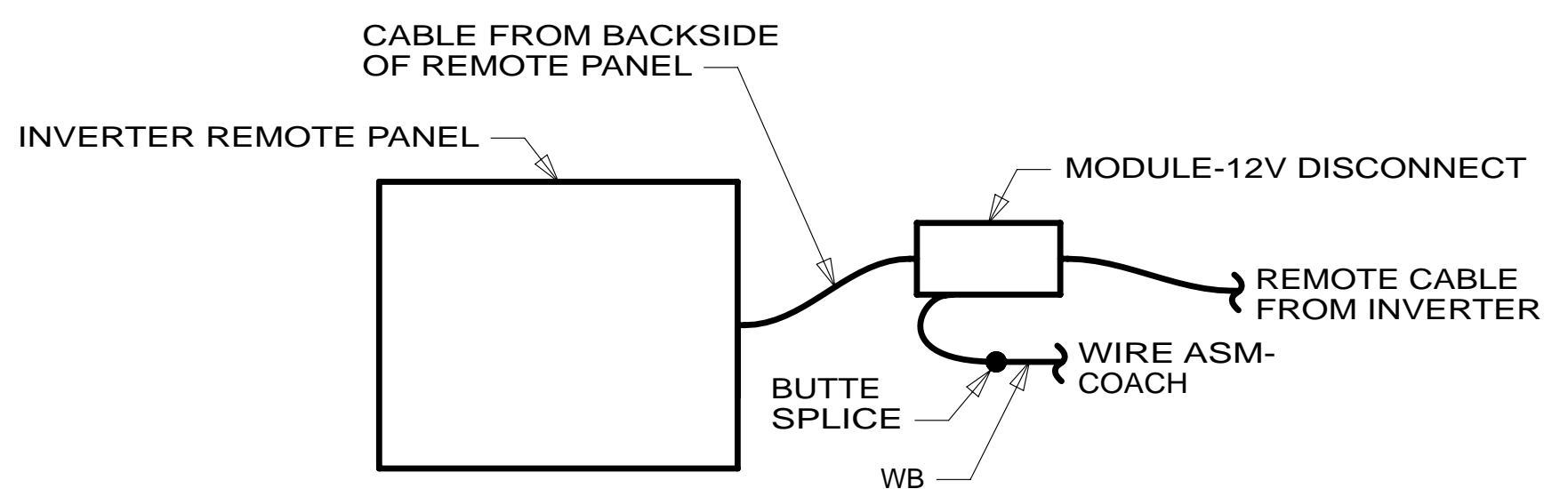

DETAIL BC

FOR ELECTRICAL
TORQUE
SPECIFICATIONS
SEE DWG NO.
128783-01-000

FOR ELECTRICAL
CALLOUTS
SEE DWG NO.
121339-01-000

FIRST USED		14 E27N	
DO NOT SCALE DRAWING			
TITLE: WIRING INSTL-BODY,12V			
SHEET 2	PART NO	185721	REV

* 185721 *

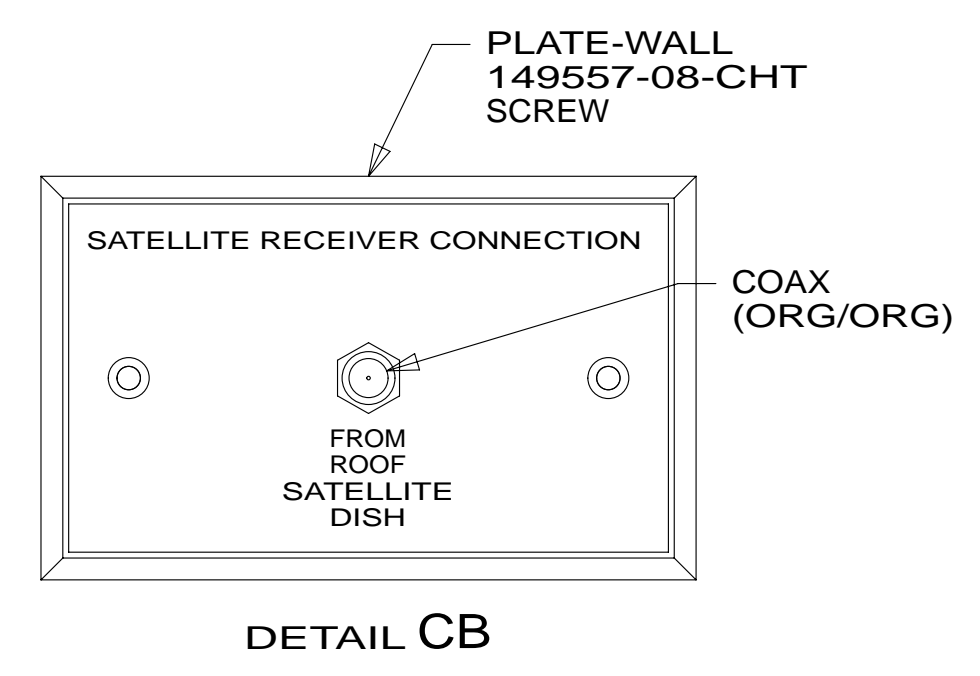
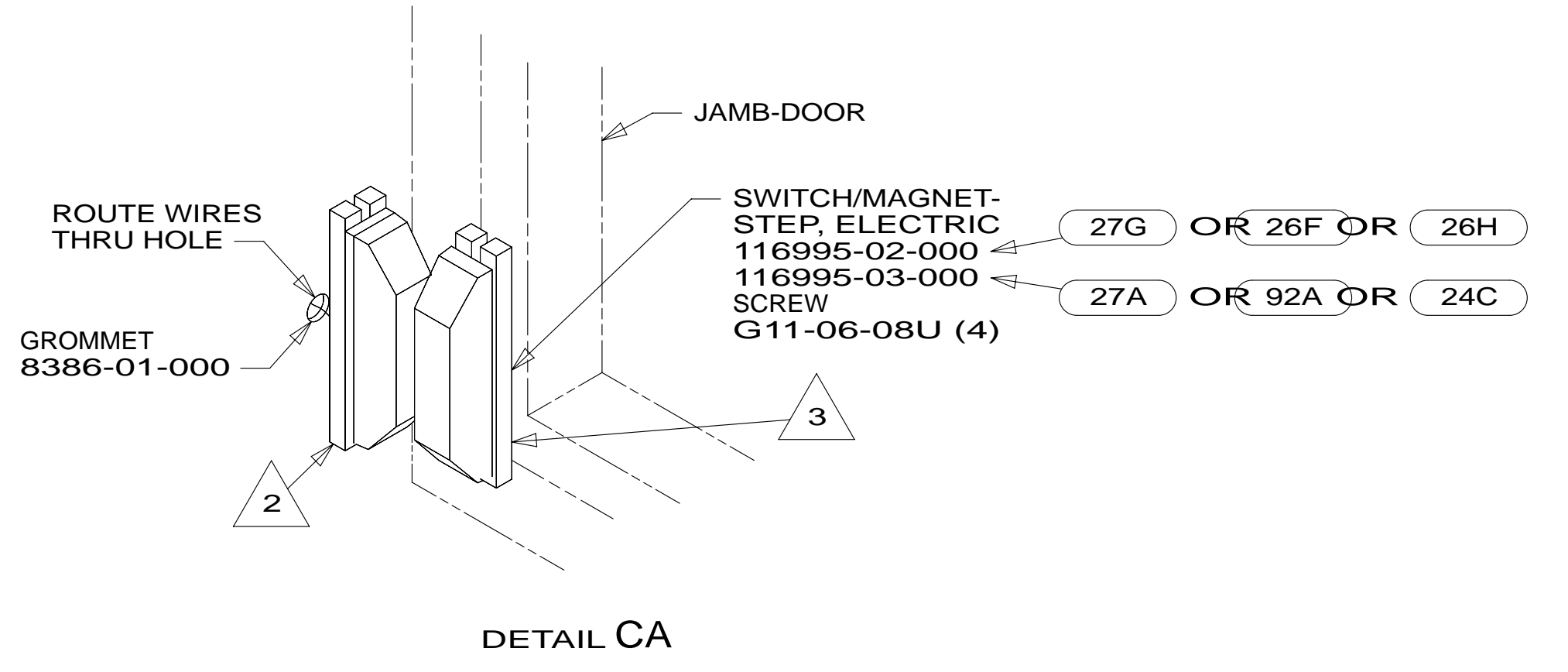
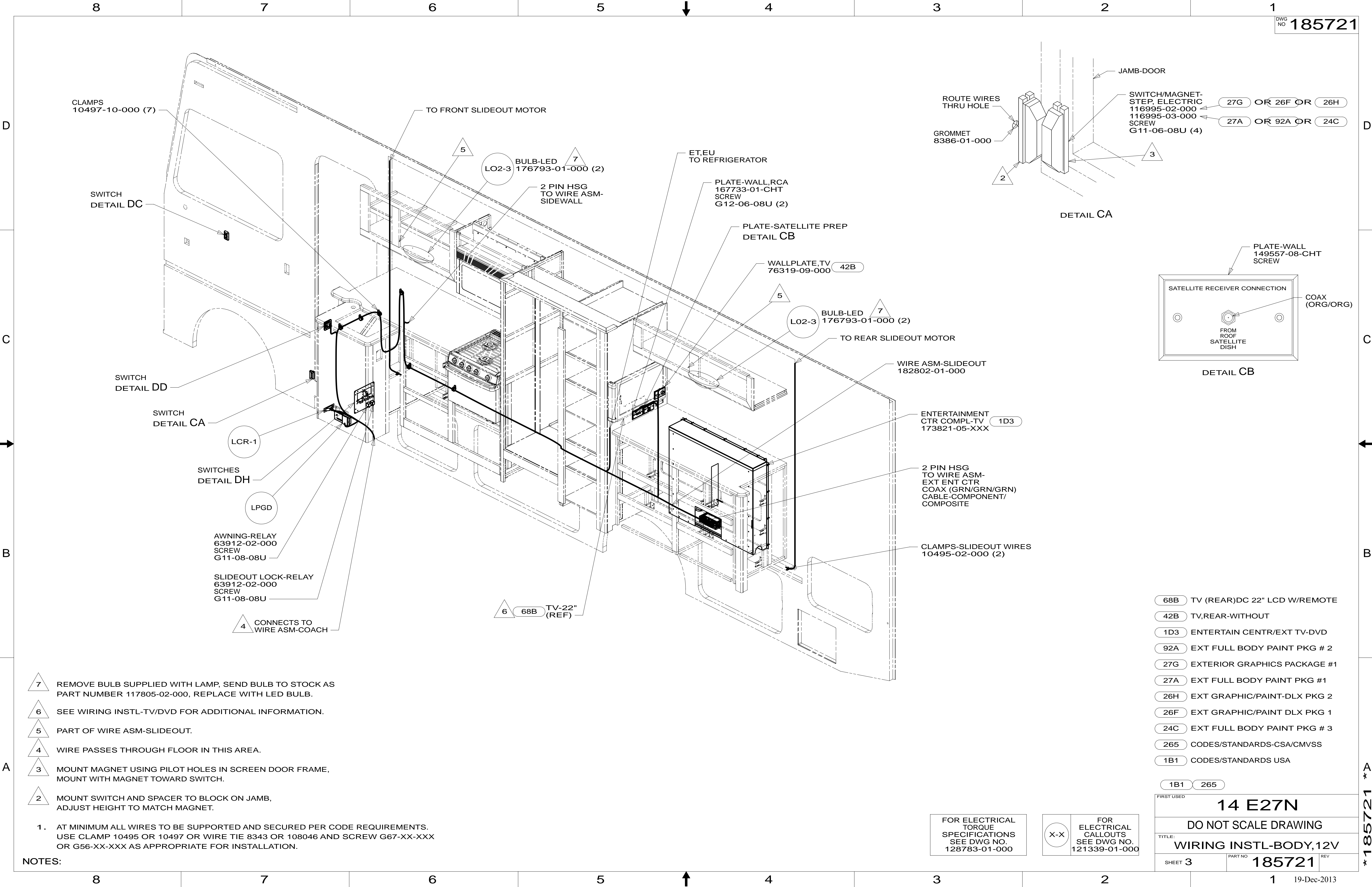

- 7 REMOVE BULB SUPPLIED WITH LAMP, SEND BULB TO STOCK AS PART NUMBER 117805-02-000, REPLACE WITH LED BULB.
- 6 SEE WIRING INSTL-TV/DVD FOR ADDITIONAL INFORMATION.
- 5 PART OF WIRE ASM-SLIDEOUT.
- 4 WIRE PASSES THROUGH FLOOR IN THIS AREA.
- 3 MOUNT MAGNET USING PILOT HOLES IN SCREEN DOOR FRAME, MOUNT WITH MAGNET TOWARD SWITCH.
- 2 MOUNT SWITCH AND SPACER TO BLOCK ON JAMB, ADJUST HEIGHT TO MATCH MAGNET.

NOTES:
 1. AT MINIMUM ALL WIRES TO BE SUPPORTED AND SECURED PER CODE REQUIREMENTS. USE CLAMP 10495 OR 10497 OR WIRE TIE 8343 OR 108046 AND SCREW G67-XX-XXX OR G56-XX-XXX AS APPROPRIATE FOR INSTALLATION.

- 68B TV (REAR)DC 22" LCD W/REMOTE
- 42B TV,REAR-WITHOUT
- 1D3 ENTERTAIN CENTR/EXT TV-DVD
- 92A EXT FULL BODY PAINT PKG # 2
- 27G EXTERIOR GRAPHICS PACKAGE #1
- 27A EXT FULL BODY PAINT PKG #1
- 26H EXT GRAPHIC/PAINT-DLX PKG 2
- 26F EXT GRAPHIC/PAINT DLX PKG 1
- 24C EXT FULL BODY PAINT PKG # 3
- 265 CODES/STANDARDS-CSA/CMVSS
- 1B1 CODES/STANDARDS USA

FOR ELECTRICAL TORQUE SPECIFICATIONS SEE DWG NO. 128783-01-000

FOR ELECTRICAL CALLOUTS SEE DWG NO. 121339-01-000

FIRST USED
14 E27N
 DO NOT SCALE DRAWING
 TITLE: **WIRING INSTL-BODY,12V**
 SHEET 3 PART NO **185721** REV
 19-Dec-2013

* 185721 *

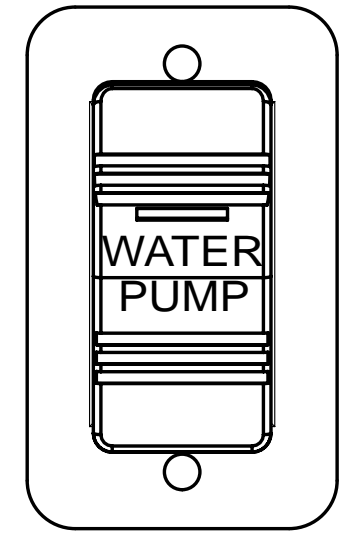

SWITCH-PUMP
108357-15-000
ACTUATOR
108356-23-CHT
PLATE
98351-07-CHT
SCREW
G11-06-10U (2)

DETAIL DA
(2 PLACES)

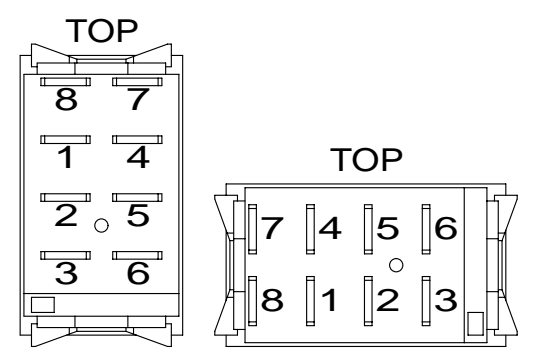

DETAIL DE

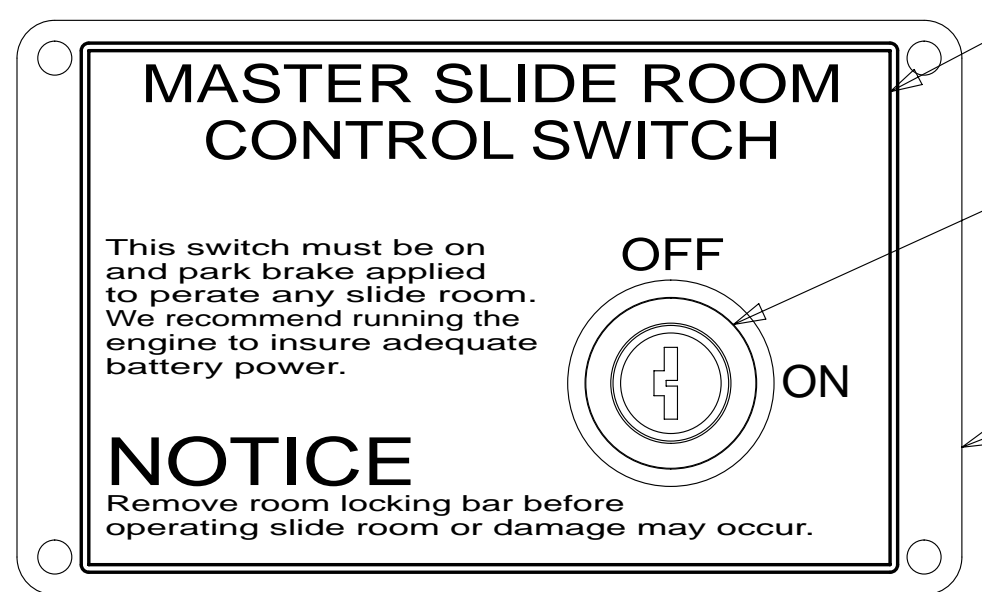

LABEL-SLIDROOM CONTROL,MAN 163988-01-CHT
SWITCH-KEY,SPST-ILLINOIS LCK 163097-01-000 (CONNECTS TO CIRCUITS DY & DDJ)
PLATE-KEY, SLIDE ROOM 163987-01-CHT SCREW 76790-05-000 (4)

MASTER SLIDE ROOM CONTROL SWITCH

This switch must be on and park brake applied to operate any slide room. We recommend running the engine to insure adequate battery power.

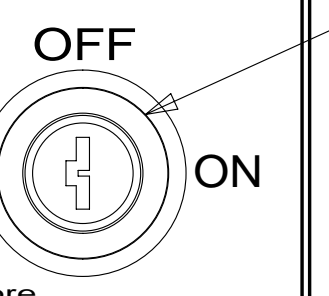

NOTICE

Remove room locking bar before operating slide room or damage may occur.

LABEL-WARNING,SLIDEOUT 116549-01-000

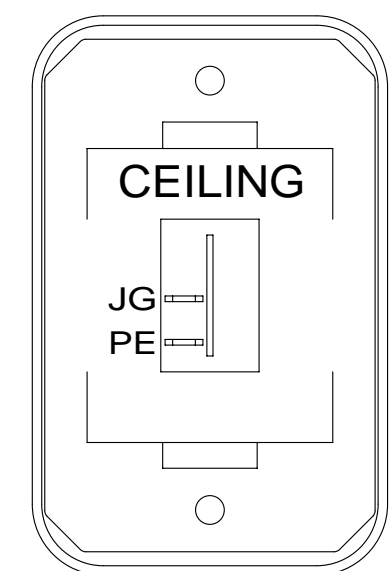
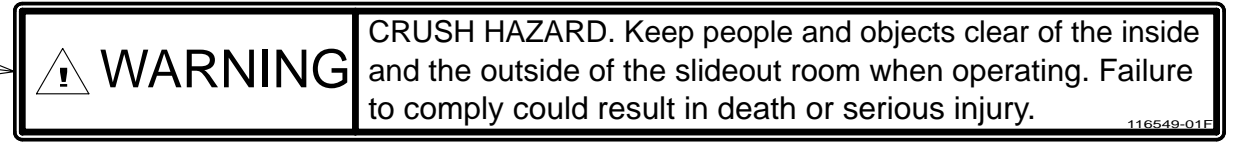

SWITCH-ROCKER 135740-01-CHT
SWITCH-BASE 135741-01-CHT
SWITCH-BEZEL 135742-07-CHT
SCREW
G11-08-08U (2)

DETAIL DB

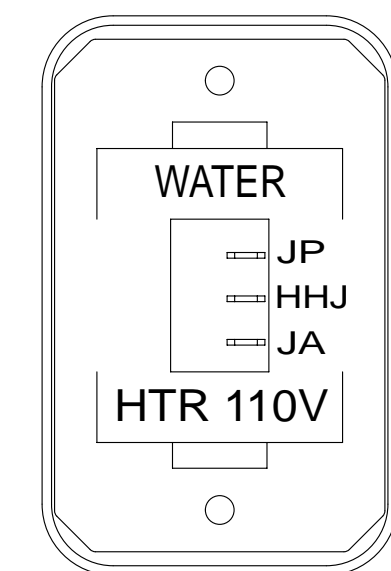

SWITCH-ROCKER 135740-06-CHT
SWITCH-BASE 135741-01-CHT
SWITCH-BEZEL 135742-35-CHT
SCREW
G11-08-08U (2)

DETAIL DF

SWITCH 108357-06-000
ACTUATOR 108356-24-CHT
CIRCUITS BBM,DT,BBN, BBA,DDJ,BBA

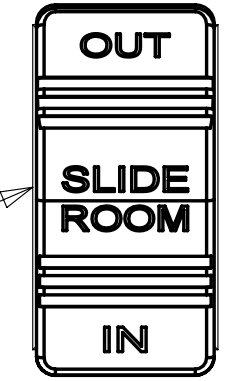

DRIVER'S SIDE REAR

LABEL-SLIDEOUT, DRIVER,REAR 163992-02-CHT

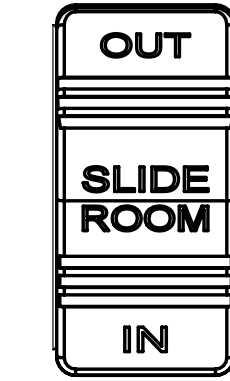

DRIVER'S SIDE FRONT

LABEL-SLIDEOUT, DRIVER,FRONT 163992-01-CHT

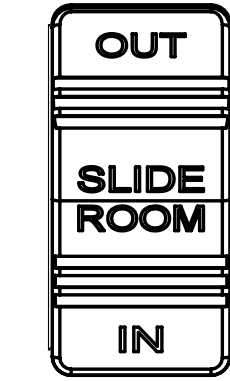

PASSENGER'S SIDE REAR

LABEL-SLIDEOUT PASS,REAR 163992-03-CHT

SWITCH 108357-06-000
ACTUATOR 108356-24-CHT
CIRCUITS DR,DT,DU, BBA,DDJ,BBA
SWITCH 108357-06-000
ACTUATOR 108356-24-CHT
CIRCUITS LLZ,DT,MMC, BBA,DDJ,BBA

DETAIL DG

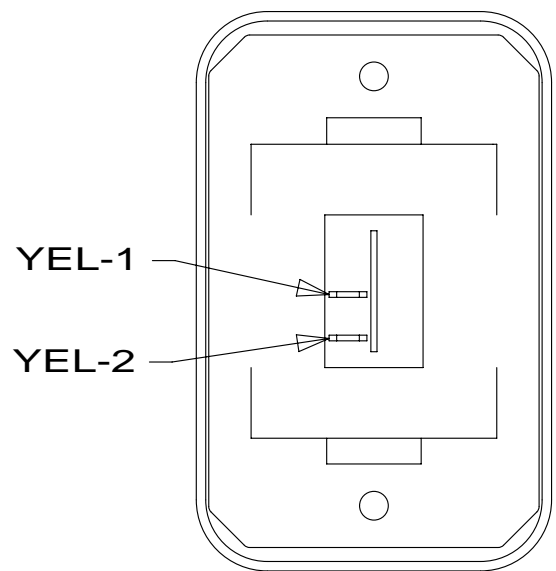

SWITCH-ROCKER 135740-01-CHT
SWITCH-BASE 135741-01-CHT
SWITCH-BEZEL 135742-01-CHT
SCREW
G11-08-08U (2)

DETAIL DC

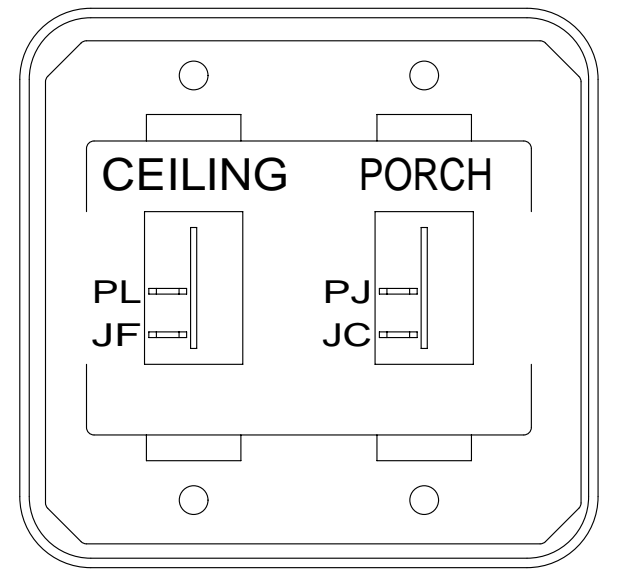

SWITCH-ROCKER 135740-01-CHT (2)
SWITCH-BASE 135741-02-CHT
SWITCH-BEZEL 135742-19-CHT
SCREW
G11-08-08U (4)

DETAIL DD

SWITCH-AWNING 108357-06-000
ACTUATOR-SWITCH 108356-12-CHT
CIRCUITS FFD,FFR,FFE, FFE,JJR,FFD

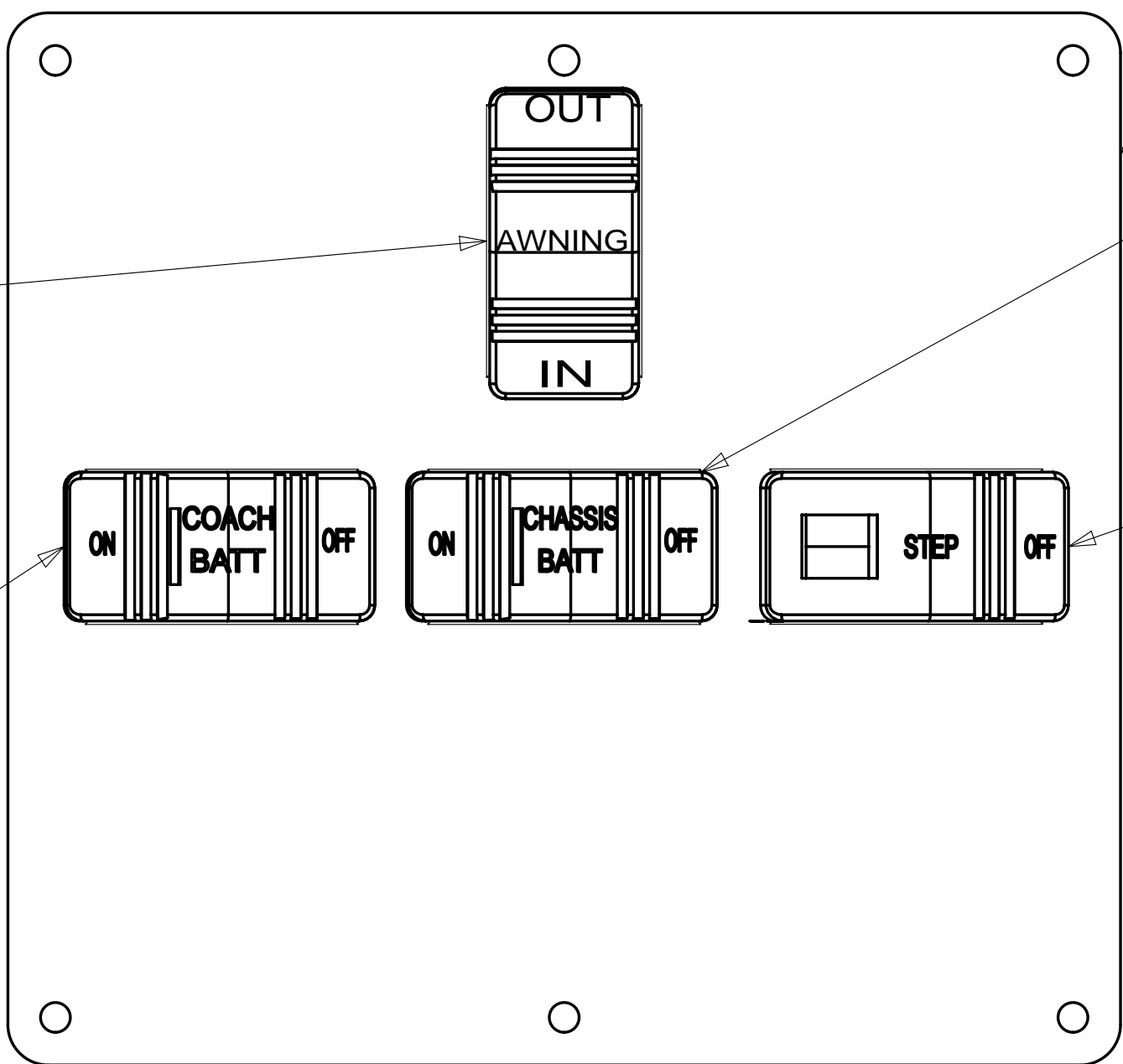

DETAIL DH 1

PLATE-SWITCH 158431-26-CHT
SCREW
G11-06-10U (6)

SWITCH-CHASSIS BATTERY 108357-18-000
ACTUATOR-SWITCH 108356-20-CHT
CIRCUITS UUC,TTY,UUB UUB,TTZ,MK WIRE ASM-THERM 186796-01-000

SWITCH-STEP 108357-19-000
CIRCUITS ER,ES

SWITCH-COACH BATT 108357-18-000
ACTUATOR-SWITCH 108356-19-CHT
CIRCUITS KF,LG,LJ,LH,WC WIRE ASM-THERM 186796-01-000

265 CODES/STANDARDS-CSA/CMVSS

1B1 CODES/STANDARDS USA

1B1 265

FIRST USED 14 E27N

DO NOT SCALE DRAWING

TITLE: WIRING INSTL-BODY,12V

SHEET 4 PART NO 185721 REV

FOR ELECTRICAL TORQUE SPECIFICATIONS SEE DWG NO. 128783-01-000

FOR ELECTRICAL CALLOUTS SEE DWG NO. 121339-01-000

NOTES:
1 FOR SWITCH ORIENTATION SEE DETAIL DE

* 185721 * A

8

7

6

5

4

3

2

1

D

D

C

C

B

B

A

A

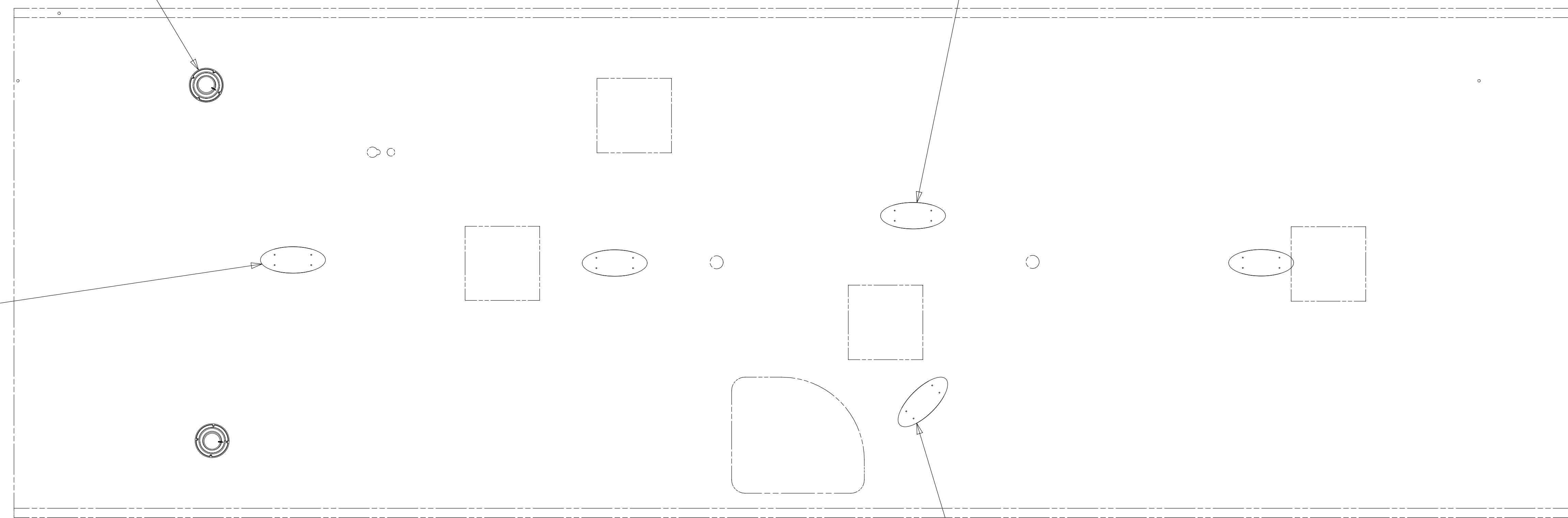

- 2 REMOVE BULB SUPPLIED WITH LAMP, SEND BULB TO STOCK AS PART NUMBER 117805-02-000, REPLACE WITH LED BULB.
- 1 SENSOR SUPPLIED WITH SATELLITE ASSEMBLY.

NOTES:

FOR ELECTRICAL TORQUE SPECIFICATIONS SEE DWG NO. 128783-01-000

FOR ELECTRICAL CALLOUTS SEE DWG NO. 121339-01-000

- 255 RADIO/AM/FM/CD/DVD PLAYER
- 265 CODES/STANDARDS-CSA/CMVSS
- 1B1 CODES/STANDARDS USA

1B1 265

FIRST USED	14 E27N	
DO NOT SCALE DRAWING		
TITLE:	WIRING INSTL-BODY,12V	
SHEET 5	PART NO 185721	REV

*185721 *A

8

7

6

5

4

3

2

1

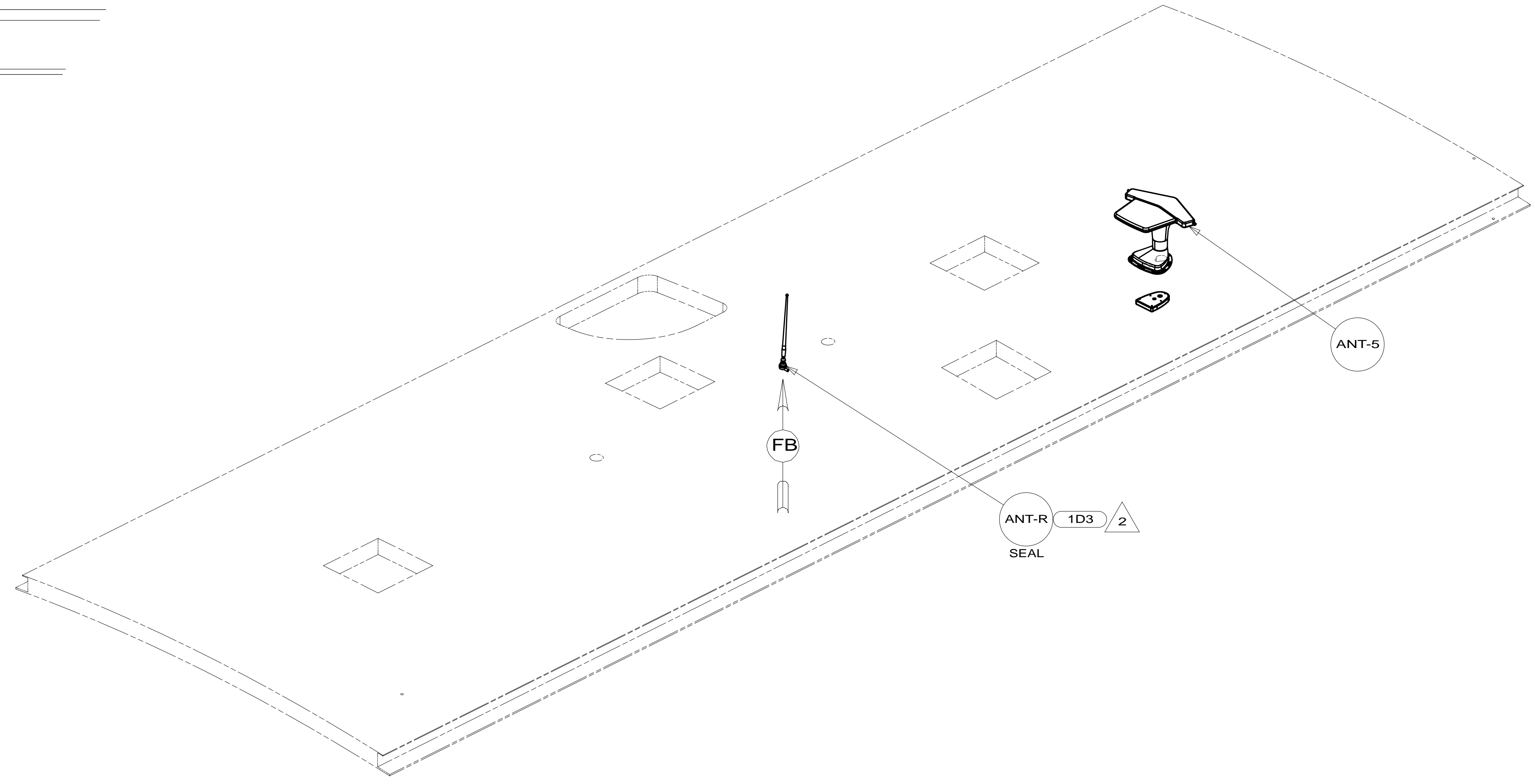
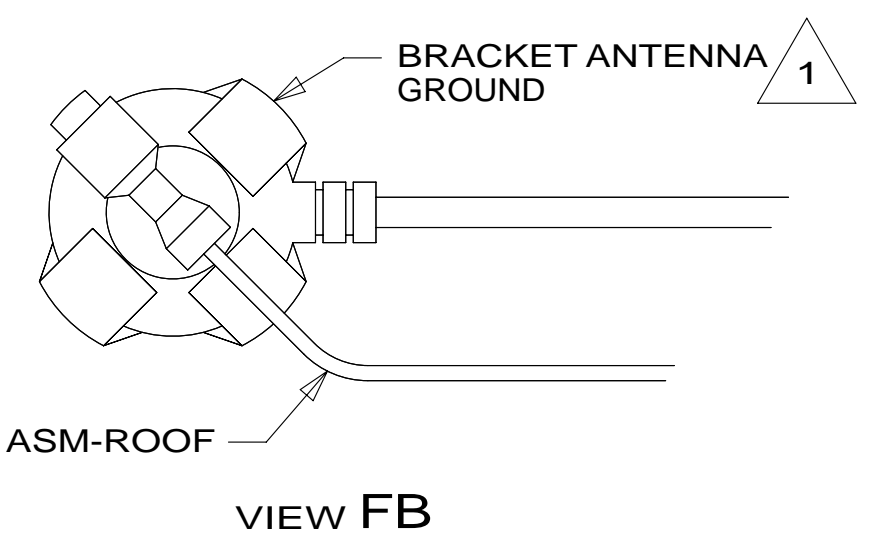
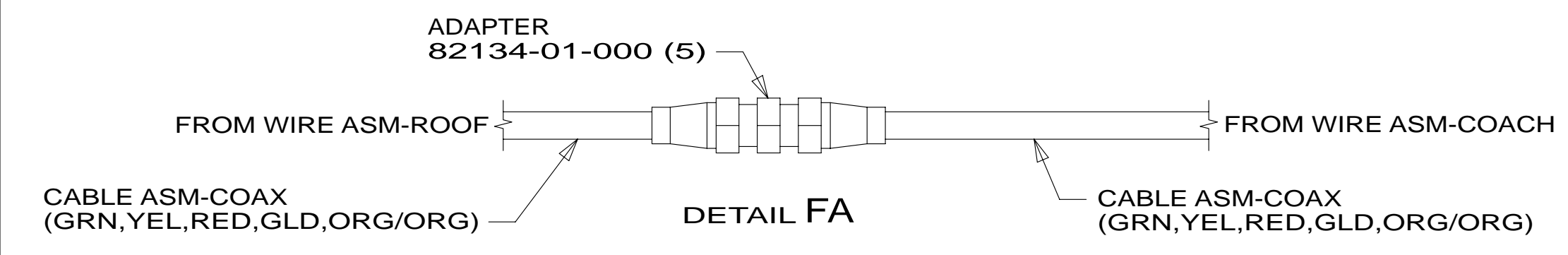

- NOTES:
- 2 REMOVE GROUND WIRE FROM ANTENNA BASE.
 - 1 WRAP LEGS AROUND ANTENNA BASE.

- 1D3 ENTERTAIN CENTR/EXT TV-DVD
- 265 CODES/STANDARDS-CSA/CMVSS
- 1B1 CODES/STANDARDS USA

- 1B1 265

FOR ELECTRICAL TORQUE SPECIFICATIONS SEE DWG NO. 128783-01-000

FOR ELECTRICAL CALLOUTS SEE DWG NO. 121339-01-000

FIRST USED		14 E27N	
DO NOT SCALE DRAWING			
TITLE: WIRING INSTL-BODY,12V			
SHEET 6	PART NO	185721	REV

*185721 *A