



**DANGER**

**Danger of electrical shock, burns or death.** Always remove all power sources before attempting any repair, service or diagnostic work. Power can be present from shore power, generator, inverter or battery. All power sources must be disabled and secured before performing any service.



**CAUTION**

If you lack the skills, tools or equipment to perform diagnostic or repair work leave such work to an authorized Winnebago Industries dealer or other qualified shop.





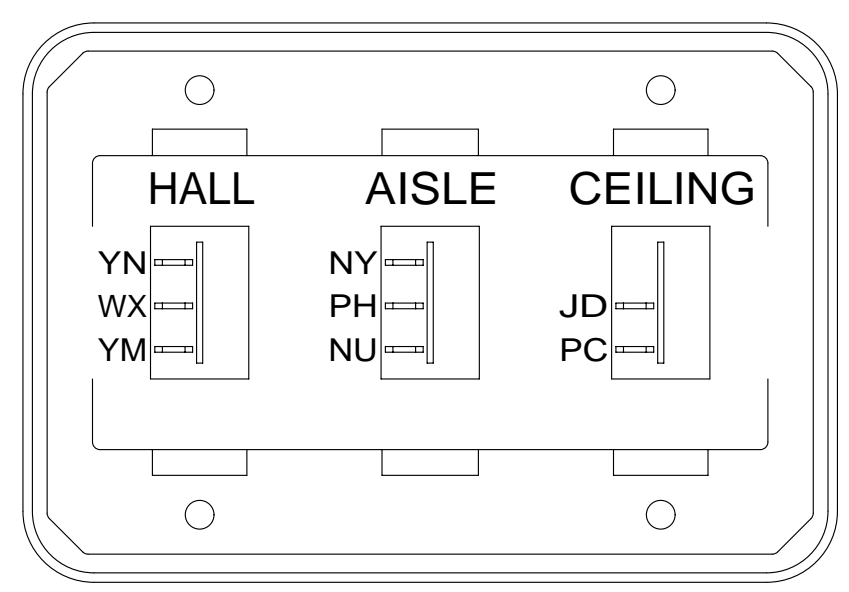

SWITCH-ROCKER  
135740-01-CHT  
135740-02-CHT (2)  
SWITCH-BASE  
135741-03-CHT  
SWITCH-BEZEL  
135742-25-CHT  
SCREW  
G11-08-08U (4)

DETAIL CA

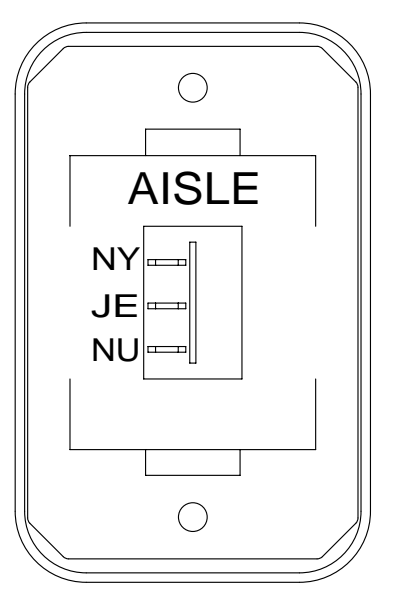

SWITCH-ROCKER  
135740-02-CHT  
SWITCH-BASE  
135741-01-CHT  
SWITCH-BEZEL  
135742-06-CHT  
SCREW  
G11-08-08U (2)

DETAIL CE

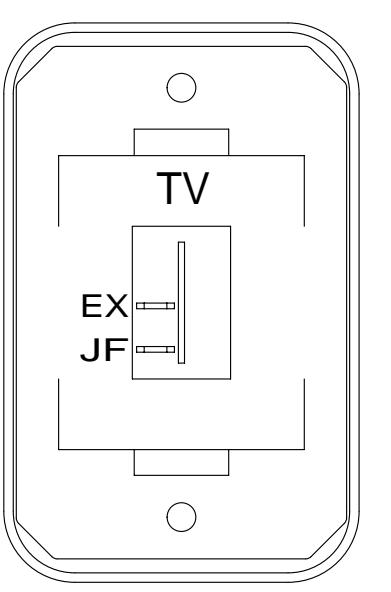

SWITCH-ROCKER  
135740-01-CHT  
SWITCH-BASE  
135741-01-CHT  
SWITCH-BEZEL  
135742-45-CHT  
SCREW  
G11-08-08U (2)

DETAIL CJ

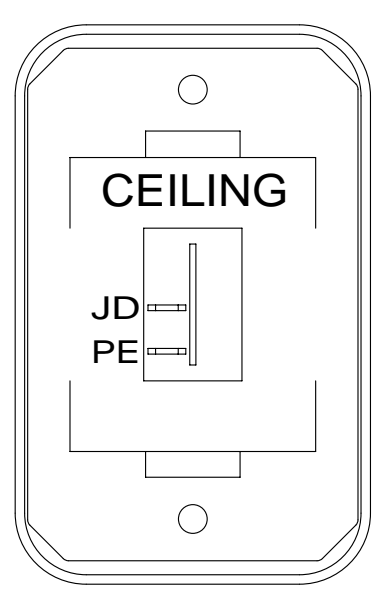

SWITCH-ROCKER  
135740-01-CHT  
SWITCH-BASE  
135741-01-CHT  
SWITCH-BEZEL  
135742-07-CHT  
SCREW  
G11-08-08U (2)

DETAIL CB

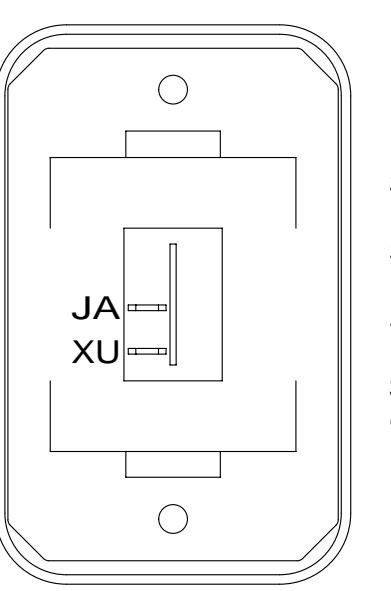

SWITCH-ROCKER  
135740-01-CHT  
SWITCH-BASE  
135741-01-CHT  
SWITCH-BEZEL  
135742-01-CHT  
SCREW  
G11-08-08U (2)

DETAIL CK

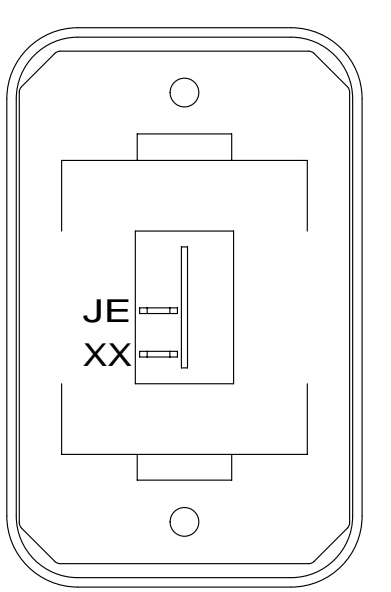

SWITCH-ROCKER  
135740-01-CHT  
SWITCH-BASE  
135741-01-CHT  
SWITCH-BEZEL  
135742-01-CHT  
SCREW  
G11-08-08U (2)

DETAIL CC

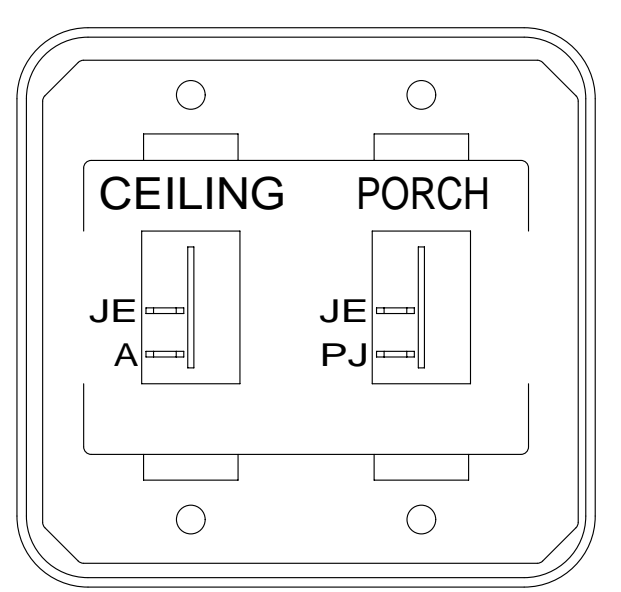

SWITCH-ROCKER  
135740-01-CHT (2)  
SWITCH-BASE  
135741-02-CHT  
SWITCH-BEZEL  
135742-19-CHT  
SCREW  
G11-08-08U (4)

DETAIL CG

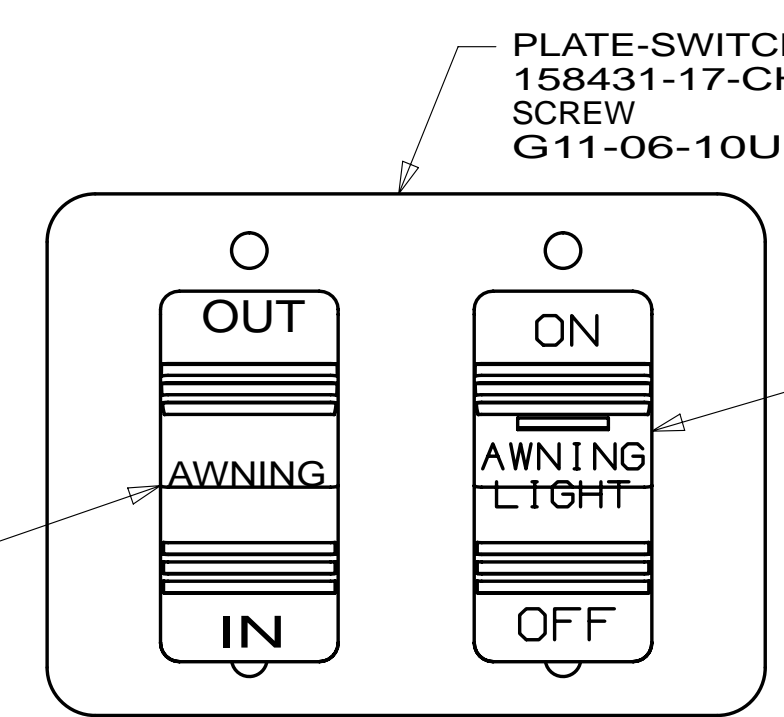

PLATE-SWITCH  
158431-17-CHT  
SCREW  
G11-06-10U (4)

DETAIL CL 52N

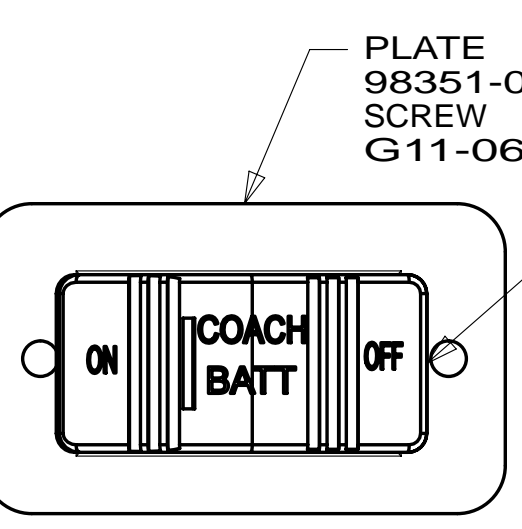
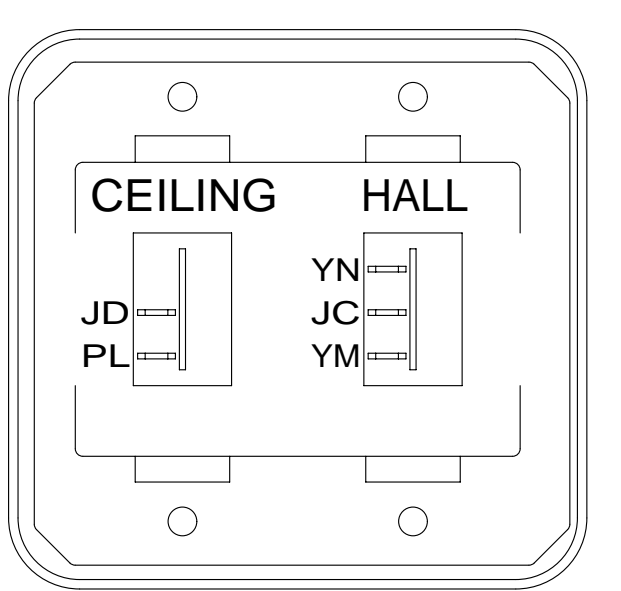

PLATE  
98351-07-CHT  
SCREW  
G11-06-10U (4)

SWITCH-BATT DISC  
108357-17-000  
ACTUATOR  
108356-19-CHT  
(CIRCUITS LH, LJ,  
LG, JP, JA)  
WIRE ASM. THERM.  
186796-01-000

DETAIL CD



SWITCH-ROCKER  
135740-01-CHT  
135740-02-CHT  
SWITCH-BASE  
135741-02-CHT  
SWITCH-BEZEL  
135742-16-CHT  
SCREW  
G11-08-08U (4)

DETAIL CH

PLATE-SWITCH  
144363-09-CHT  
SWITCH  
108357-06-000  
ACTUATOR  
108356-01-CHT  
NUT  
D65-08-00U (2)  
LABEL  
116220-01-000

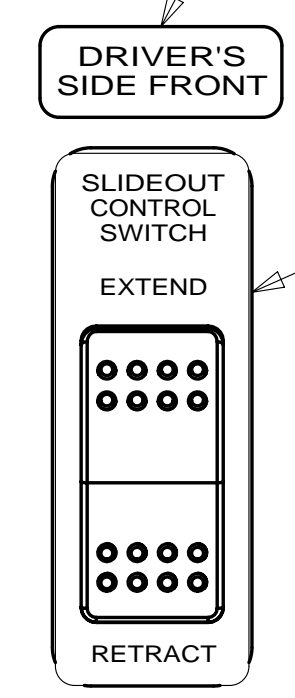
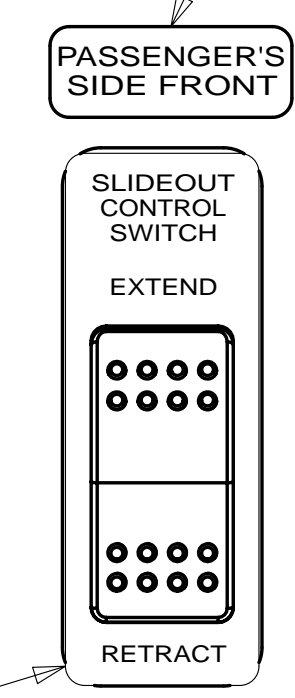
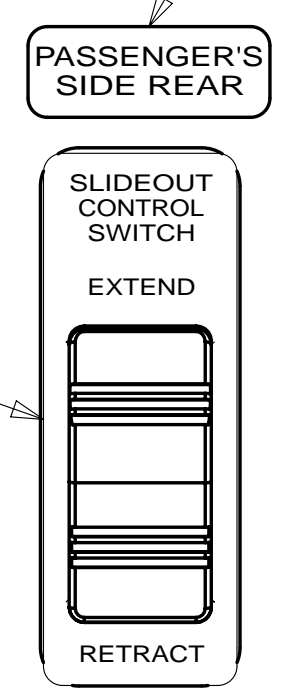

LABEL-SLIDEOUT,PASS,REAR  
163992-03-CHT

LABEL-SLIDEOUT,PASS,FRONT  
163992-04-CHT

LABEL-SLIDEOUT,DRIVER,FRONT  
163992-01-CHT

PLATE-SWITCH  
144363-09-CHT  
SWITCH  
108357-06-000  
ACTUATOR  
108356-01-CHT  
NUT  
D65-08-00U (2)  
LABEL  
116220-01-000

WARNING CRUSH HAZARD. Keep people and objects clear of the inside and the outside of the slideout room when operating. Failure to comply could result in death or serious injury.

LABEL-WARNING, SLIDEOUT  
116549-01-000

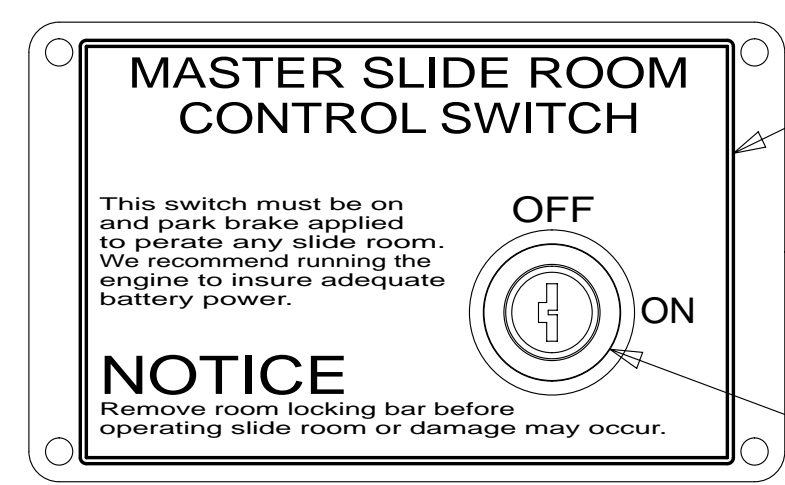

LABEL  
163988-01-CHT

PLATE-KEY, SLIDE ROOM  
163987-01-CHT  
SCREW  
76790-05-000 (4)

SWITCH-KEY,SPST-ILLINOIS LCK  
163097-01-000  
(CONNECTS TO CIRCUITS DY & DDJ)

DETAIL CM

- 52N AWNING - PATIO, ELECTRIC
- 265 CODES/STANDARDS-CSA/CMVSS
- 1B1 CODES/STANDARDS USA

1B1 265

FIRST USED	<b>14 730J</b>
<b>DO NOT SCALE DRAWING</b>	
<b>TITLE: WIRING INSTL-BODY,12V</b>	
SHEET 3	PART NO. <b>185564</b> REV
29-Apr-2014	

FOR ELECTRICAL TORQUE SPECIFICATIONS SEE DWG NO. 128783-01-000

FOR ELECTRICAL CALLOUTS SEE DWG NO. 121339-01-000

\* 185564 \*

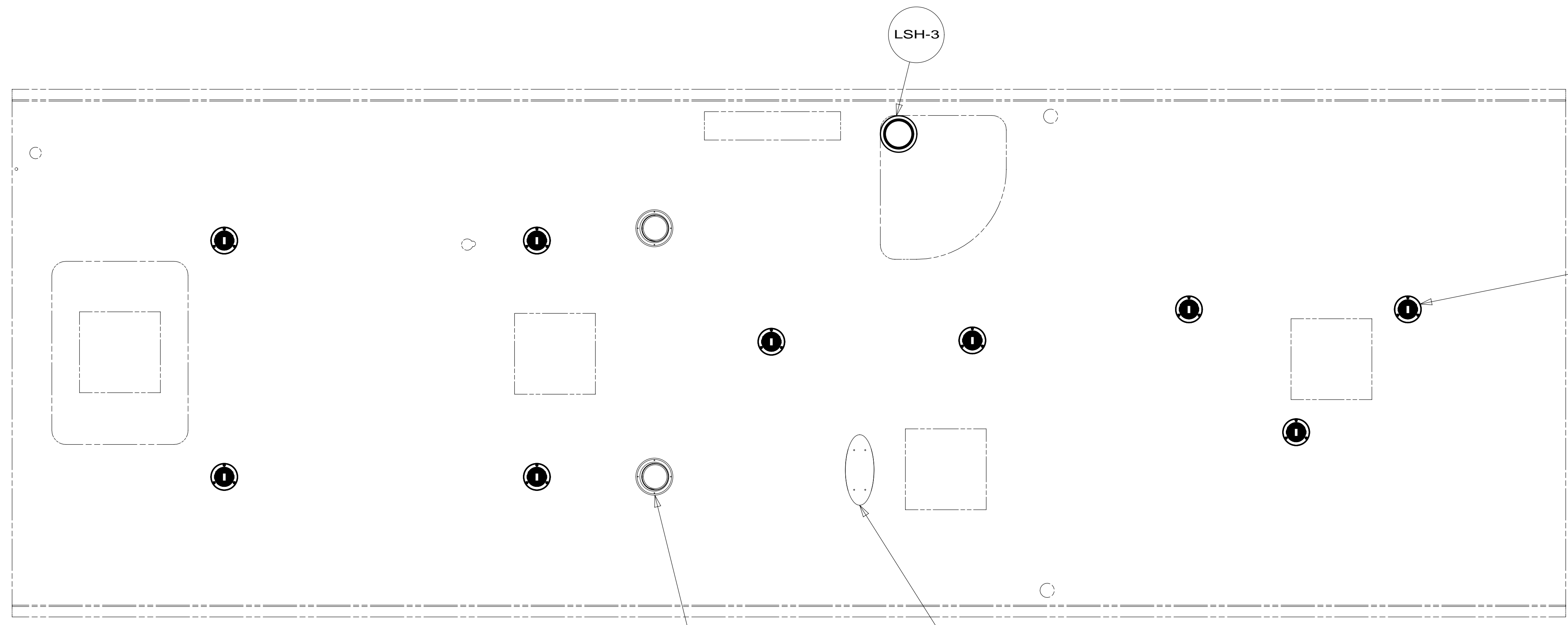

SPEAKER-ROUND  
 179783-01-CHT (2)  
 SCREW  
 G1208-12-170 (8)

LOSN3

LED-4  
 9

LSH-3

265 CODES/STANDARDS-CSA/CMVSS

1B1 CODES/STANDARDS USA

1B1 265

FIRST USED  
**14 730J**

DO NOT SCALE DRAWING

TITLE: **WIRING INSTL-BODY, 12V**

SHEET 4 PART NO **185564** REV

FOR ELECTRICAL  
 TORQUE  
 SPECIFICATIONS  
 SEE DWG NO.  
 128783-01-000

FOR ELECTRICAL  
 CALLOUTS  
 SEE DWG NO.  
 121339-01-000

X-X

NOTES:  
 1. SEE ROOF ASSEMBLY FOR ADDITIONAL INFORMATION.

\* 185564 \* A

THE SATELLITE DISH WIRE CONNECTIONS ARE TO BE PLACED ON THE CENTERLINE OF THE MOTORHOME FACING FORWARD

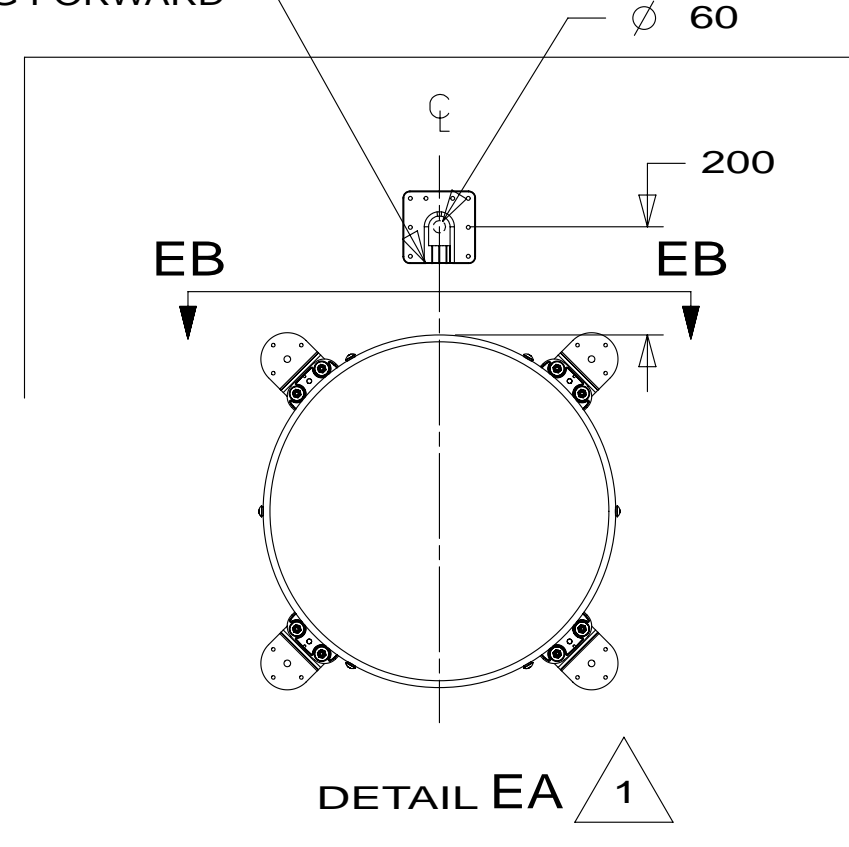

CONNECT 2-PIN HOUSING FROM ROOF ASM TO SATELLITE DISH HERE AND ADD CONVOLUTED TUBING

CONNECT CABLE ASM COAX (ORG) FROM ROOF ASM TO MAIN INPUT ON SATELLITE DISH

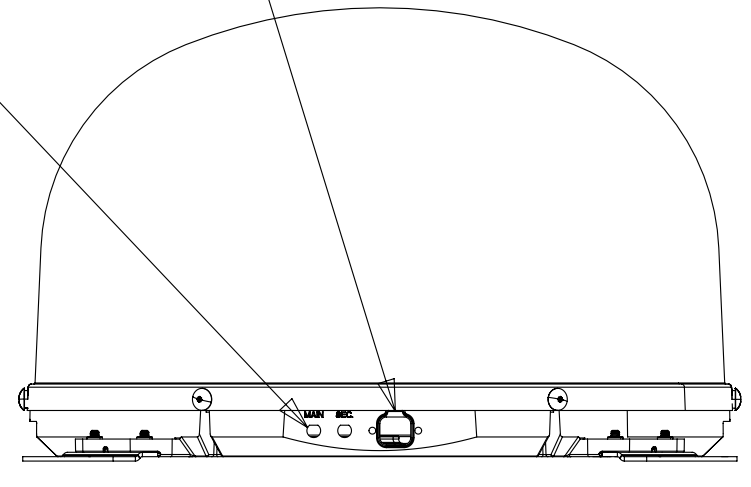

VIEW EB-EB

DA-5 78K  
DETAIL EA

DI-3 48P 3  
DETAIL EA

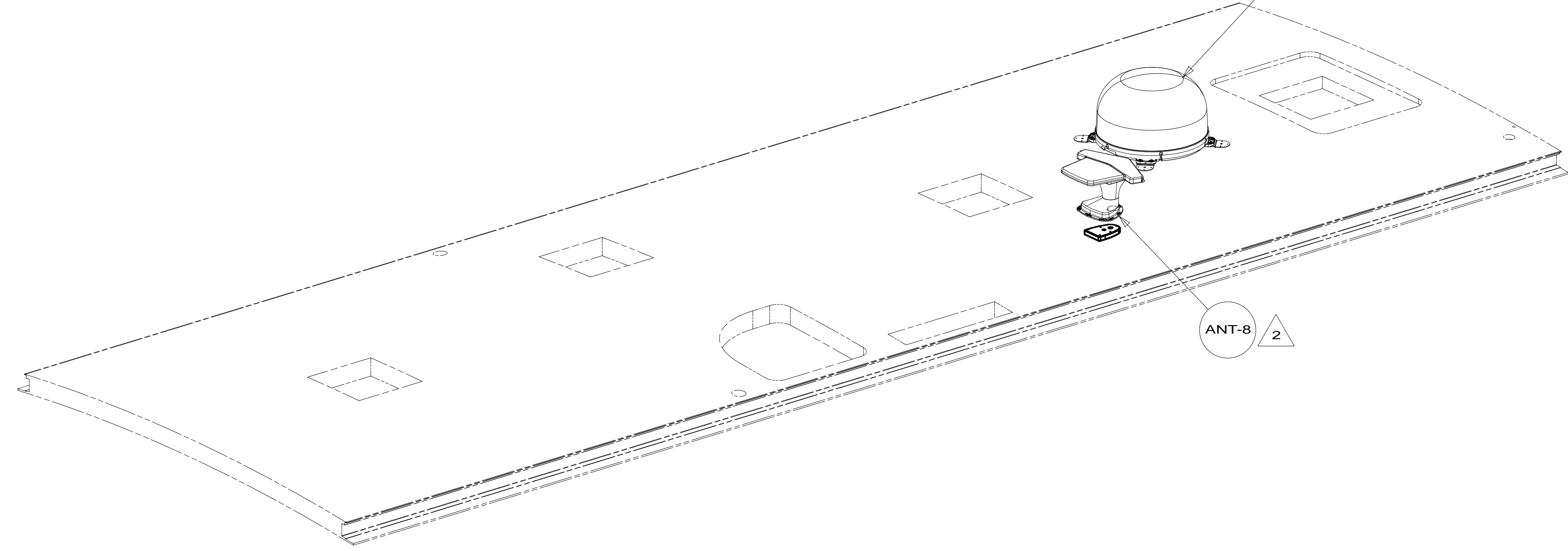

- NOTES:
- 3 ADD COAX CABLE 163598-04-000 & ADAPTOR-COAX 82134-01-000 TO ORG COAX TO MAKE CONNECTION WATER TIGHT.
  - 2 SEE ANTENNA INSTALLATION MANUAL FOR CORRECT INSTALLATION PROCEDURE.
  - 1 REMOVE ALL SHIPPING RESTRAINTS AND FIRMLY INSERT THE SUPPLIED PLUGS INTO THE APPROPRIATE SIZED HOLES AS SPECIFIED IN THE INSTALLATION PROCESS.

- 48P SAT TV SYSTEM IN-MOTION
- 78K SATELLITE TV SYSTEM AUTO
- 265 CODES/STANDARDS-CSA/CMVSS
- 1B1 CODES/STANDARDS USA

1B1 265

FIRST USED	
<b>14 730J</b>	
DO NOT SCALE DRAWING	
TITLE: <b>WIRING INSTL-BODY, 12V</b>	
SHEET 5	PART NO. <b>185564</b> REV

FOR ELECTRICAL TORQUE SPECIFICATIONS SEE DWG NO. 128783-01-000

FOR ELECTRICAL CALLOUTS SEE DWG NO. 121339-01-000

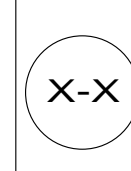

\* 185564 \* A

6 PIN HSG TO SLIDEOUT MOTOR WITH GREEN TAPE

6 PIN HSG TO SLIDEOUT MOTOR WITH YELLOW TAPE

WIRE ROUTED BEHIND TRIM PIECE IN THIS AREA

WIRE ROUTED BEHIND TRIM PIECE IN THIS AREA

WIRE ASM-SLIDEOUT MOTORS (REFERENCE)

WIRE ASM-SLIDEOUT MOTORS (REFERENCE)

VIEW FA

- 52N AWNING - PATIO, ELECTRIC
- 265 CODES/STANDARDS-CSA/CMVSS
- 1B1 CODES/STANDARDS USA

1B1 265

FIRST USED 14 730J

DO NOT SCALE DRAWING

TITLE: WIRING INSTL-BODY, 12V

SHEET 6 PART NO 185564 REV

FOR ELECTRICAL TORQUE SPECIFICATIONS SEE DWG NO. 128783-01-000

FOR ELECTRICAL CALLOUTS SEE DWG NO. 121339-01-000

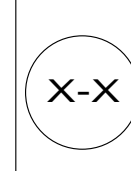

\* 185564 \* A

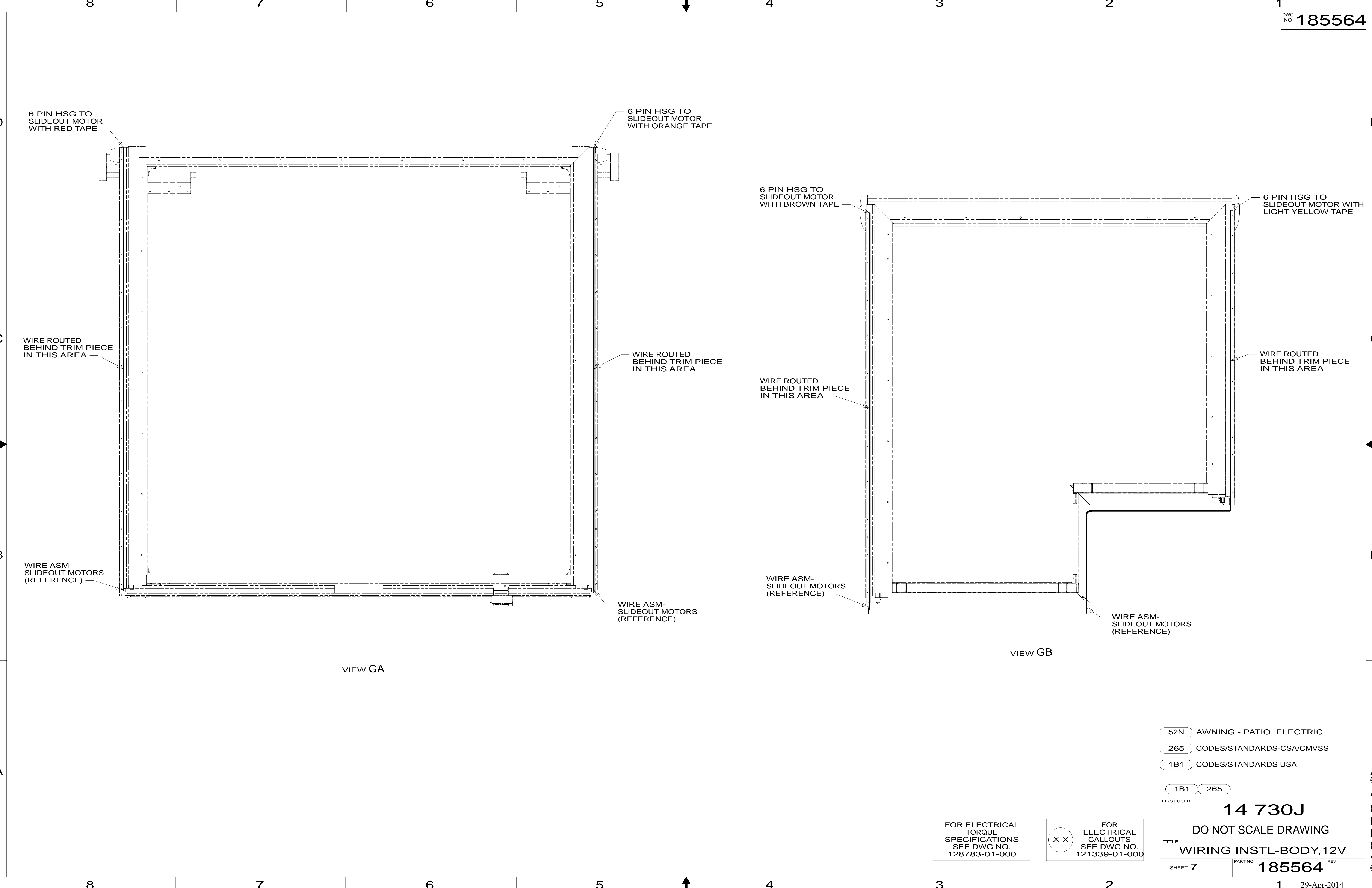

6 PIN HSG TO SLIDEOUT MOTOR WITH RED TAPE

6 PIN HSG TO SLIDEOUT MOTOR WITH ORANGE TAPE

WIRE ROUTED BEHIND TRIM PIECE IN THIS AREA

WIRE ROUTED BEHIND TRIM PIECE IN THIS AREA

WIRE ASM-SLIDEOUT MOTORS (REFERENCE)

WIRE ASM-SLIDEOUT MOTORS (REFERENCE)

VIEW GA

6 PIN HSG TO SLIDEOUT MOTOR WITH BROWN TAPE

6 PIN HSG TO SLIDEOUT MOTOR WITH LIGHT YELLOW TAPE

WIRE ROUTED BEHIND TRIM PIECE IN THIS AREA

WIRE ROUTED BEHIND TRIM PIECE IN THIS AREA

WIRE ASM-SLIDEOUT MOTORS (REFERENCE)

WIRE ASM-SLIDEOUT MOTORS (REFERENCE)

VIEW GB

- 52N AWNING - PATIO, ELECTRIC
- 265 CODES/STANDARDS-CSA/CMVSS
- 1B1 CODES/STANDARDS USA

1B1 265

FIRST USED 14 730J

DO NOT SCALE DRAWING

TITLE: WIRING INSTL-BODY,12V

SHEET 7 PART NO 185564 REV

FOR ELECTRICAL TORQUE SPECIFICATIONS SEE DWG NO. 128783-01-000

FOR ELECTRICAL CALLOUTS SEE DWG NO. 121339-01-000

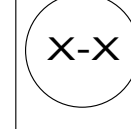

\* 185564 \* A