



DANGER

Danger of electrical shock, burns or death. Always remove all power sources before attempting any repair, service or diagnostic work. Power can be present from shore power, generator, inverter or battery. All power sources must be disabled and secured before performing any service.



CAUTION

If you lack the skills, tools or equipment to perform diagnostic or repair work leave such work to an authorized Winnebago Industries dealer or other qualified shop.

| DRAWING NO. | FEATURE |
|-------------|---------|
| 185187-01 | WIN |
| 185187-02 | ITA |

| | | | |
|----------|-----------------|--------|----------|
| RELEASE | REV/DATE | DWG NO | 185187 |
| REV ZONE | REVISION RECORD | DATE | DTR-ORIG |

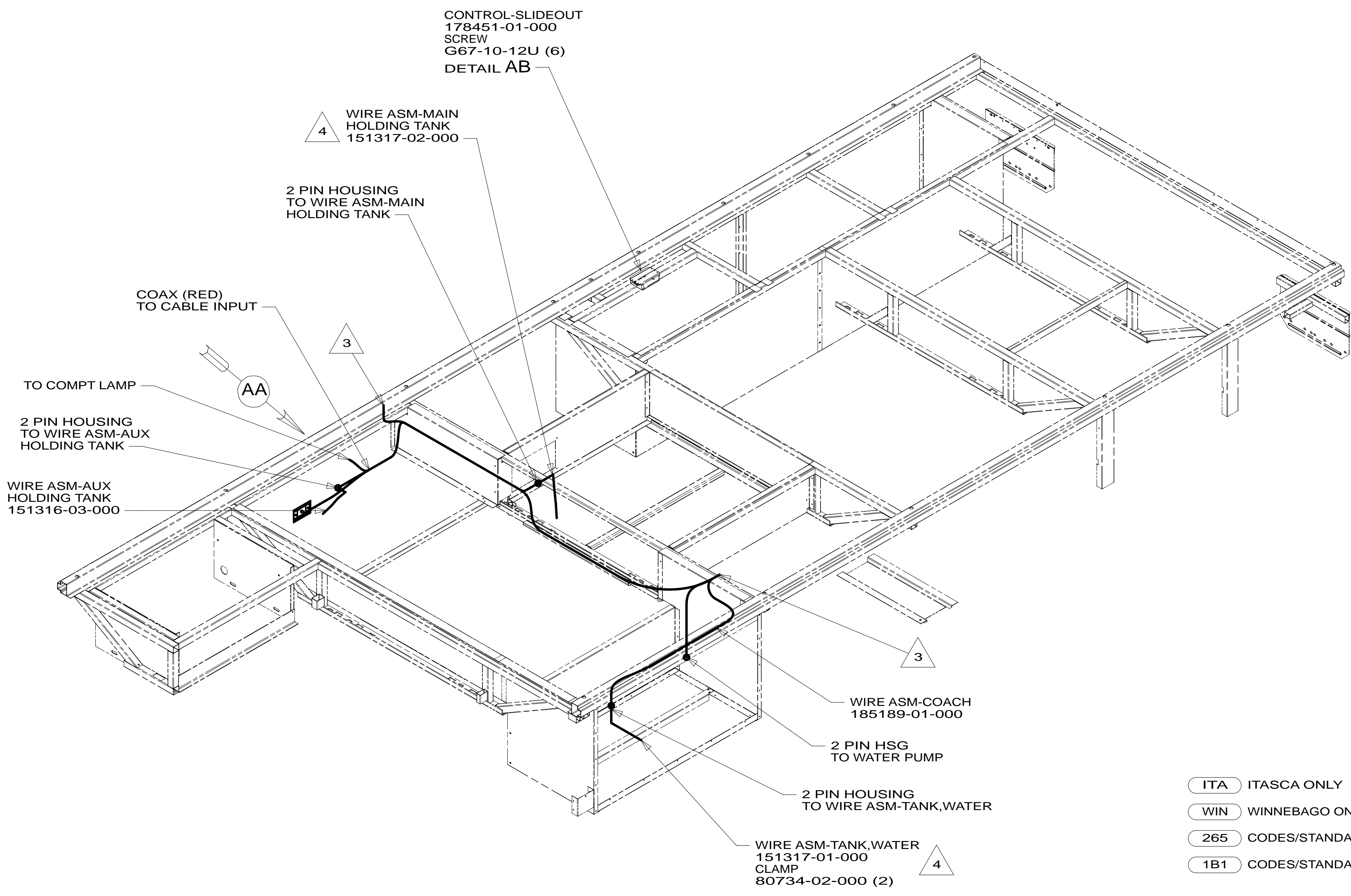
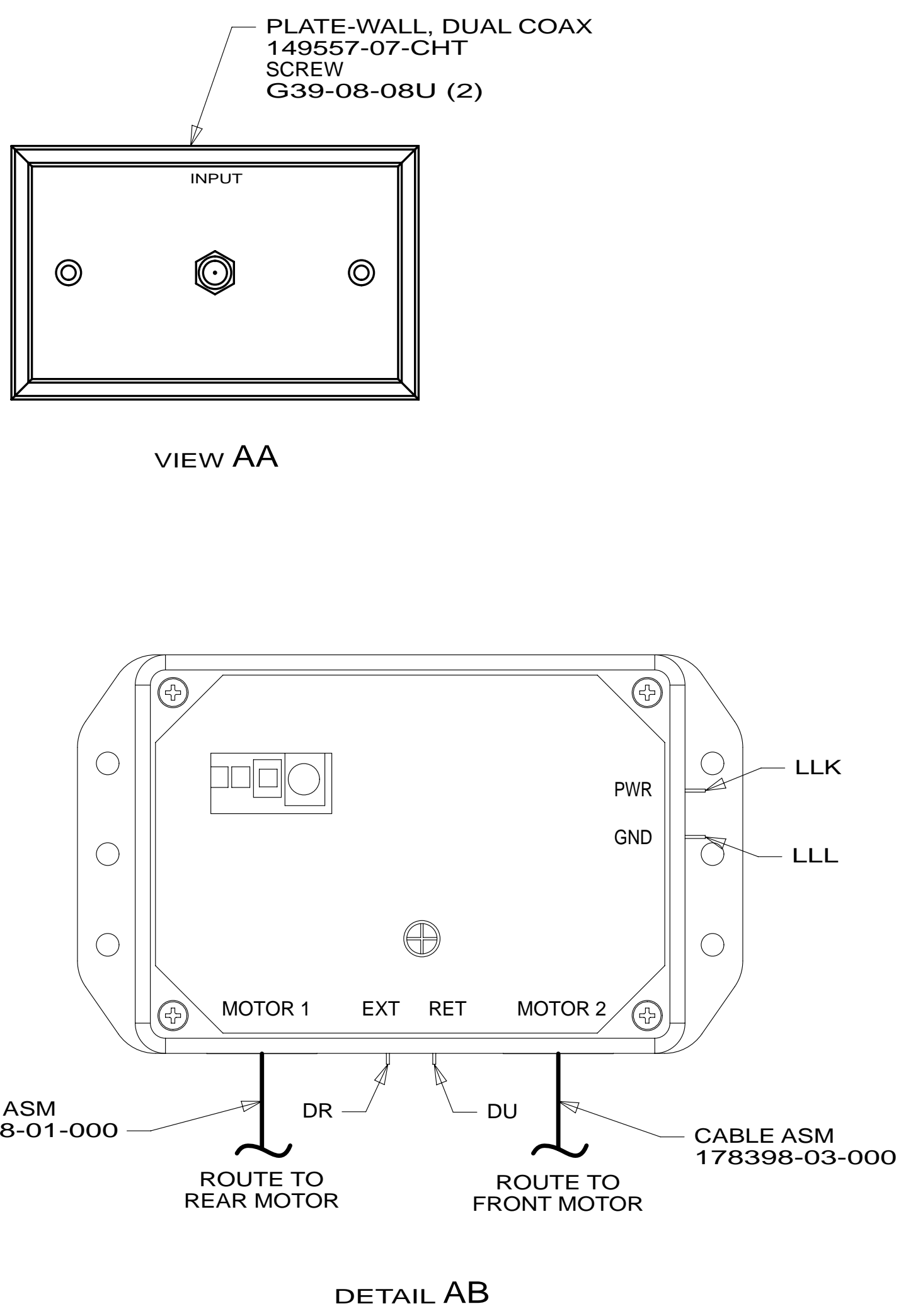

- 4 PLACE CROSS LOCATOR ON SENSORS OVER DIMPLES ON TANK.
- 3 WIRE PASSES THROUGH FLOOR IN THIS AREA.
2. ROUTE TANK SENSOR WIRES SO THEY DO NOT PASS OVER SENSORS. USE WIRE TIE MOUNT 155366-01-000 AND WIRE TIE 8343-01-000 AS NEEDED. TANK SURFACE MUST BE CLEANED USING ISOPROPYL ALCOHOL AND PRIMED WITH PRIMER 94.
 1. AT MINIMUM ALL WIRES TO BE SUPPORTED AND SECURED PER CODE REQUIREMENTS. USE CLAMP 10495 OR 10497 OR WIRE TIE 8343 OR 108046 AND SCREW G67-XX-XXX OR G56-XX-XXX AS APPROPRIATE FOR INSTALLATION.

FOR ELECTRICAL TORQUE SPECIFICATIONS SEE DWG NO. 128783-01-000

FOR ELECTRICAL CALLOUTS SEE DWG NO. 121339-01-000

- ITA ITASCA ONLY
- WIN WINNEBAGO ONLY
- 265 CODES/STANDARDS-CSA/CMVSS
- 1B1 CODES/STANDARDS USA

WINNEBAGO INDUSTRIES, INC. COPYRIGHT 2014

| | |
|------|-----------------------------------|
| DTR | ORIG. DATE |
| CHKR | ALL DIMENSIONS ARE IN MILLIMETERS |
| P.E. | |
| M.E. | FIRST USED |
| DSNR | 14 E26HE |

UNSPECIFIED TOLERANCES ARE:

| | |
|------------------|--------|
| WHOLE DIM (X) | : 3 |
| ONE-PLACE (X.X) | : 1.5 |
| TWO-PLACE (X.XX) | : 0.50 |
| ANGLE | : 1° |

THIRD ANGLE PROJECTION

DO NOT SCALE DRAWING REFER TO ES0018 FOR FASTENER TIGHTENING GUIDELINES

TITLE: **WIRING INSTL-BODY, 12V**

SHEET 1 OF 7 PART NO. **185187** REV

* 185187 *

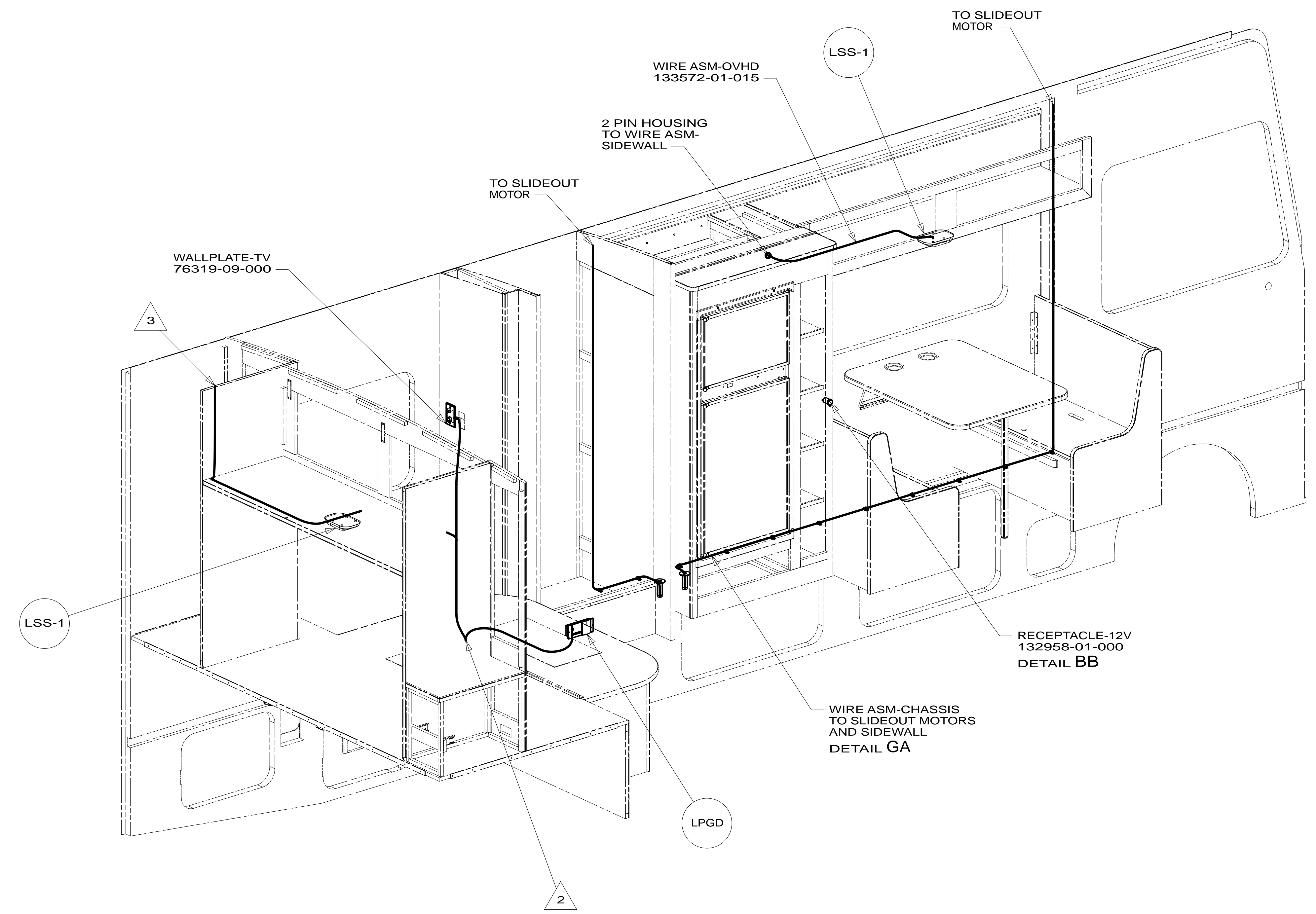
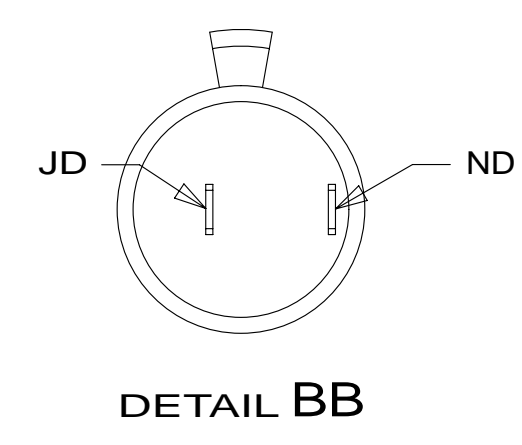

- 3 WIRE FROM ROOF.
- 2 WIRE PASSES THROUGH FLOOR IN THIS AREA.

1. AT MINIMUM ALL WIRES TO BE SUPPORTED AND SECURED PER CODE REQUIREMENTS. USE CLAMP 10495 OR 10497 OR WIRE TIE 8343 OR 108046 AND SCREW G67-XX-XXX OR G56-XX-XXX AS APPROPRIATE FOR INSTALLATION.

NOTES:

265 CODES/STANDARDS-CSA/CMVSS
 1B1 CODES/STANDARDS USA

1B1 265

FIRST USED 14 E26HE

DO NOT SCALE DRAWING

TITLE: WIRING INSTL-BODY, 12V

SHEET 2 PART NO 185187 REV

FOR ELECTRICAL TORQUE SPECIFICATIONS SEE DWG NO. 128783-01-000

FOR ELECTRICAL CALLOUTS SEE DWG NO. 121339-01-000

* 185187 * A

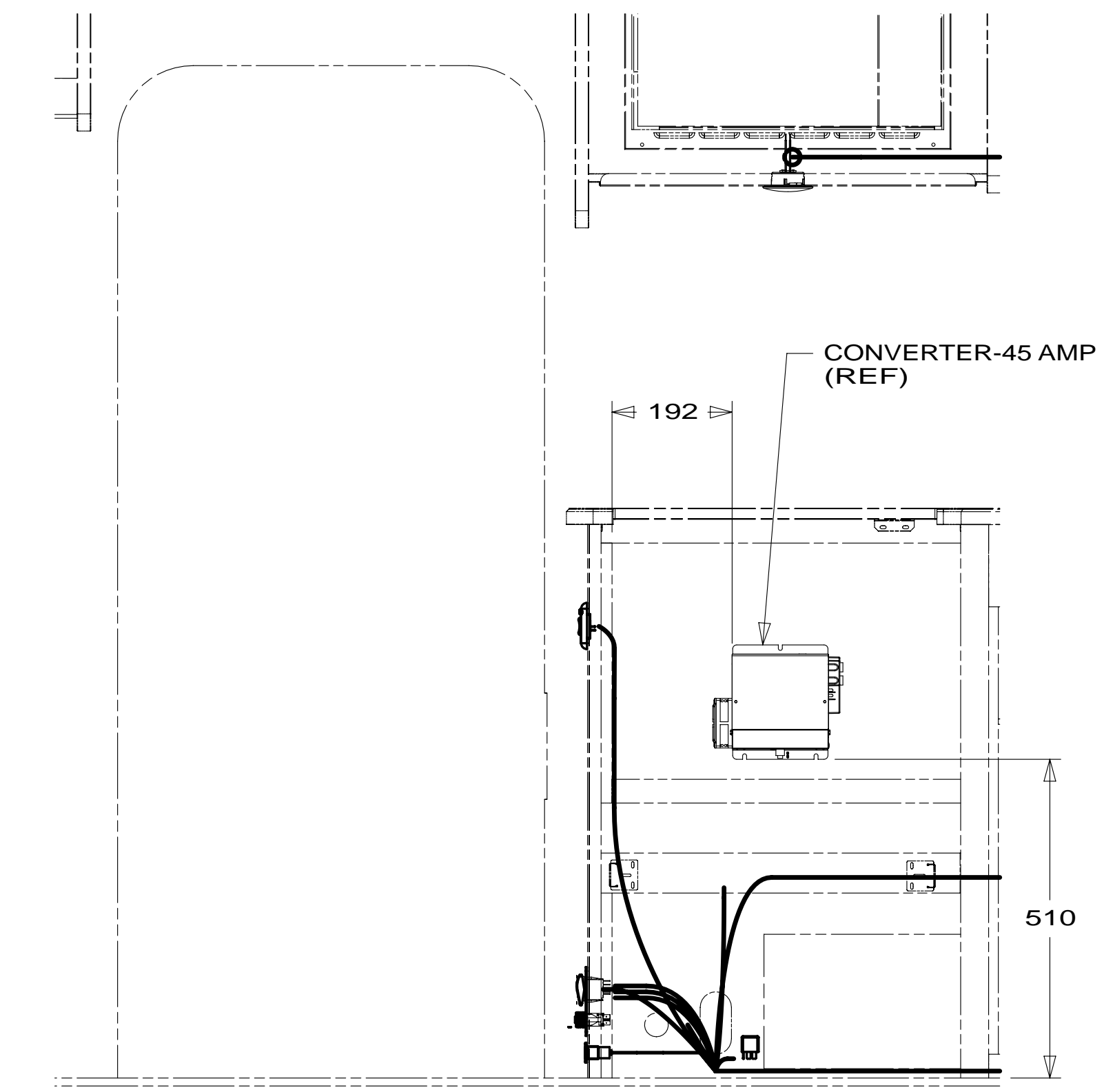
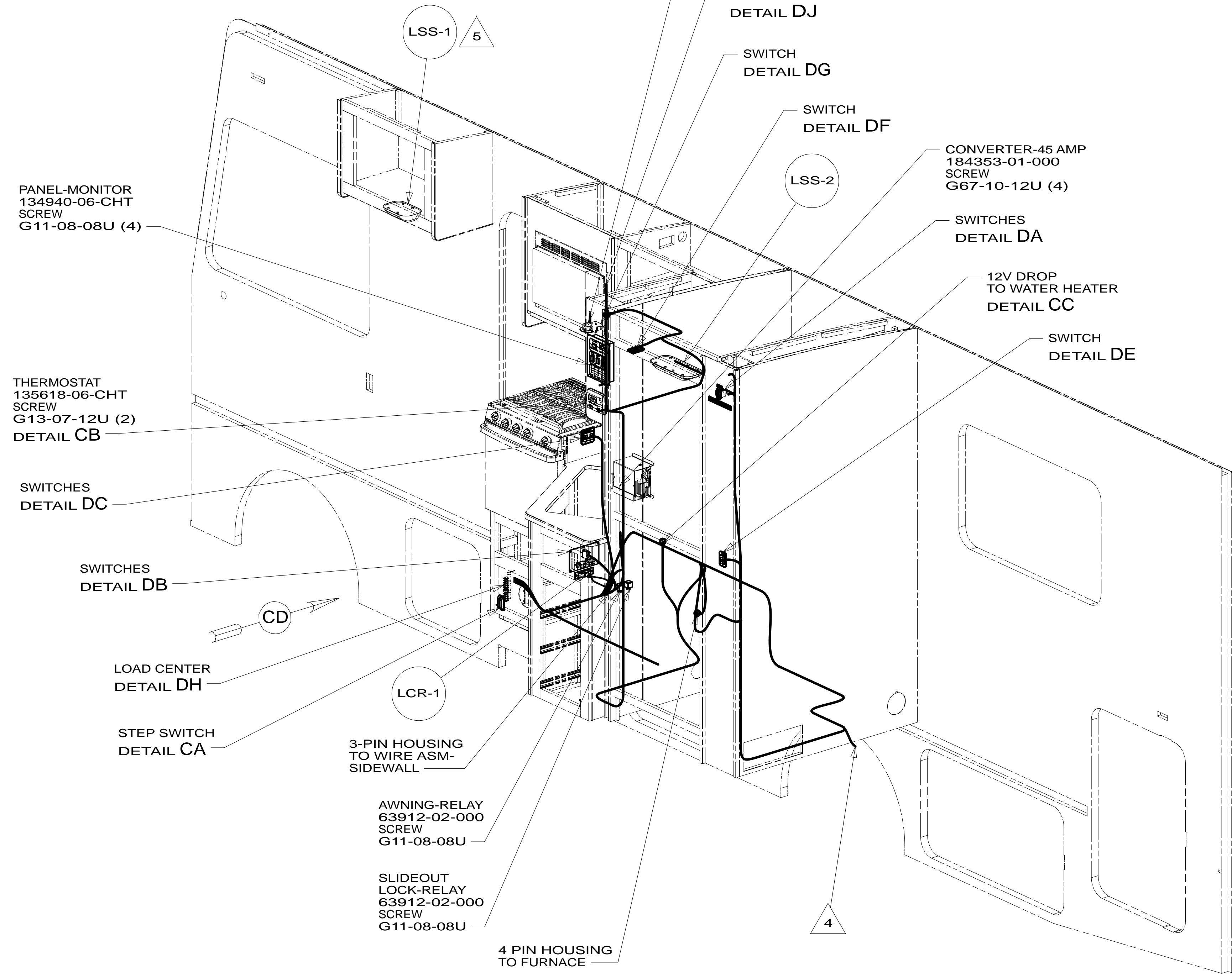
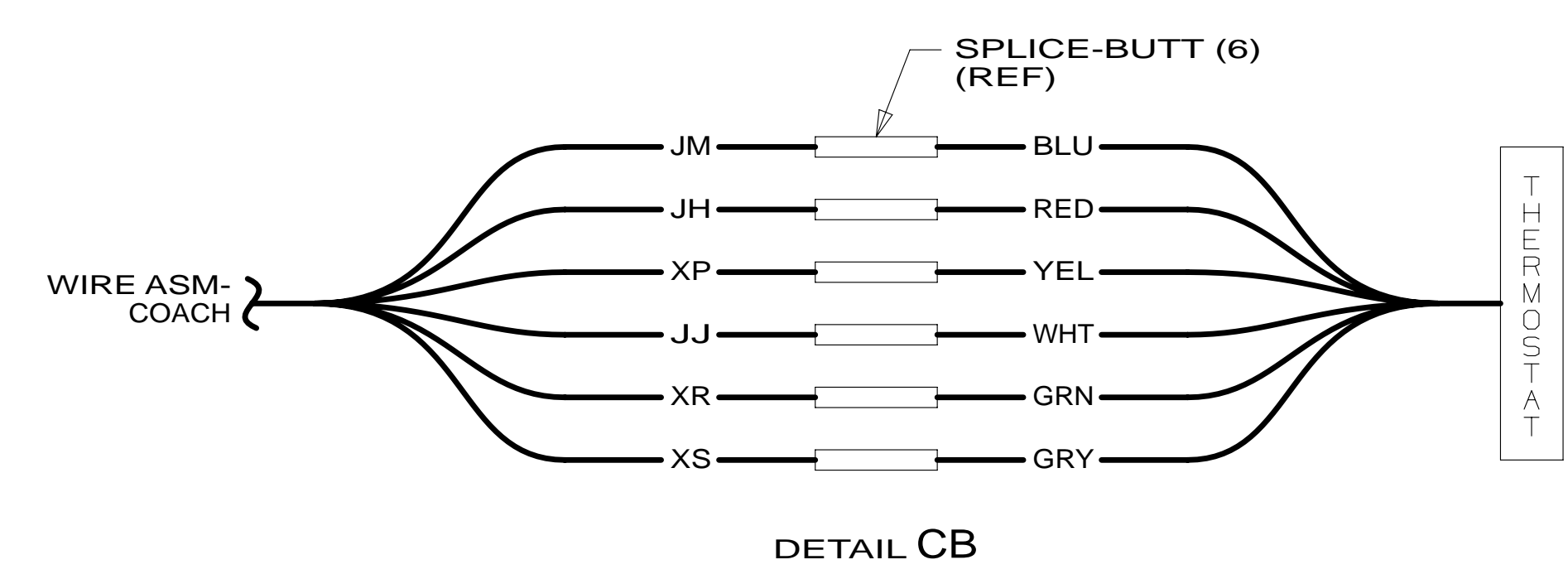
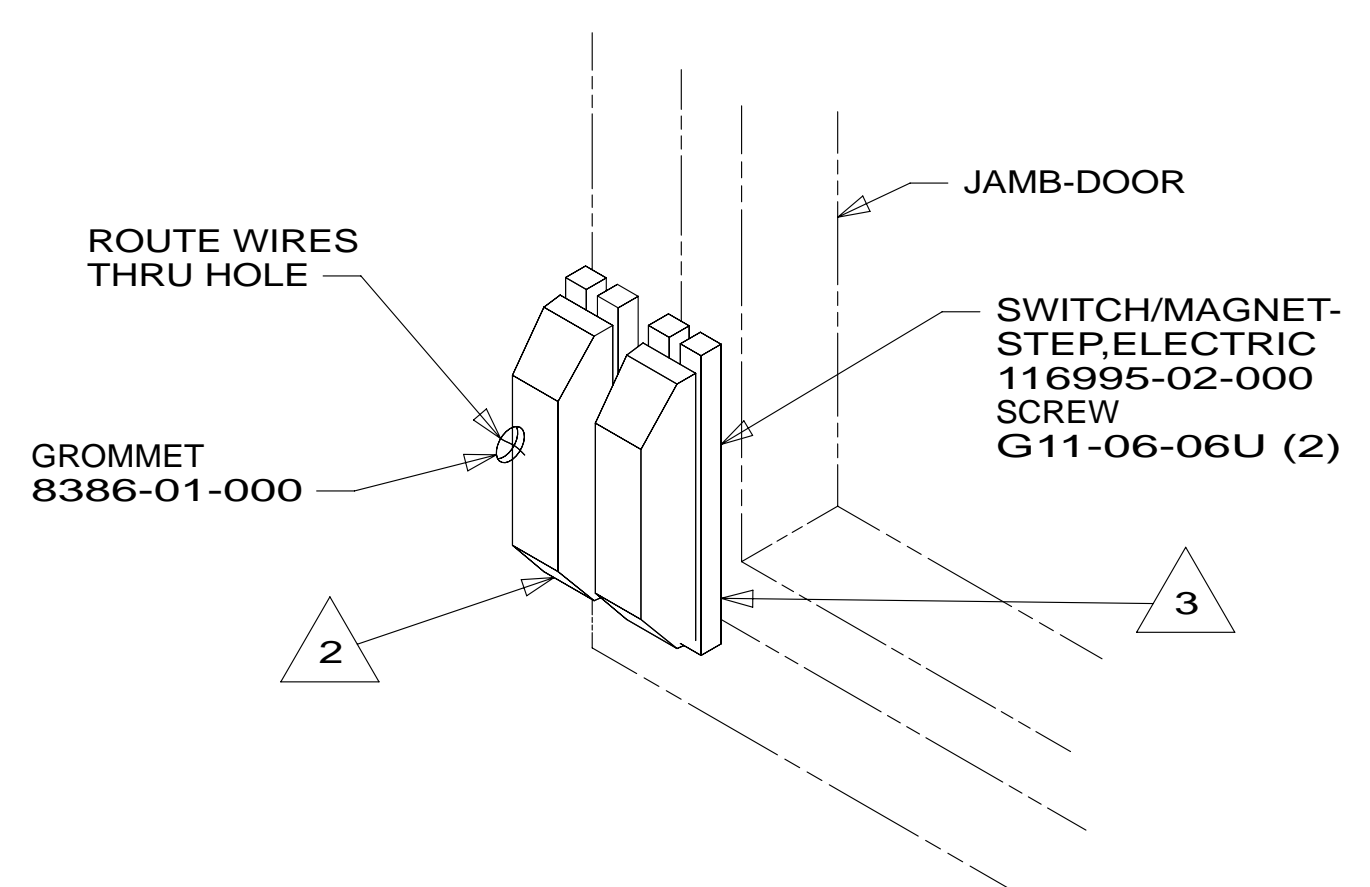

- NOTES:
- 5 THIS LIGHT NOT USED ON T3 MODEL.
 - 4 WIRE PASSES THROUGH FLOOR IN THIS AREA.
 - 3 MOUNT MAGNET TO SCREEN DOOR FRAME, MOUNT WITH MAGNET TOWARD SWITCH.
 - 2 MOUNT SWITCH TO DOOR JAMB WITH TAPE 076322-21-000.
 - 1. AT MINIMUM ALL WIRES TO BE SUPPORTED AND SECURED PER CODE REQUIREMENTS. USE CLAMP 10495 OR 10497 OR WIRE TIE 8343 OR 108046 AND SCREW G67-XX-XXX OR G56-XX-XXX AS APPROPRIATE FOR INSTALLATION.

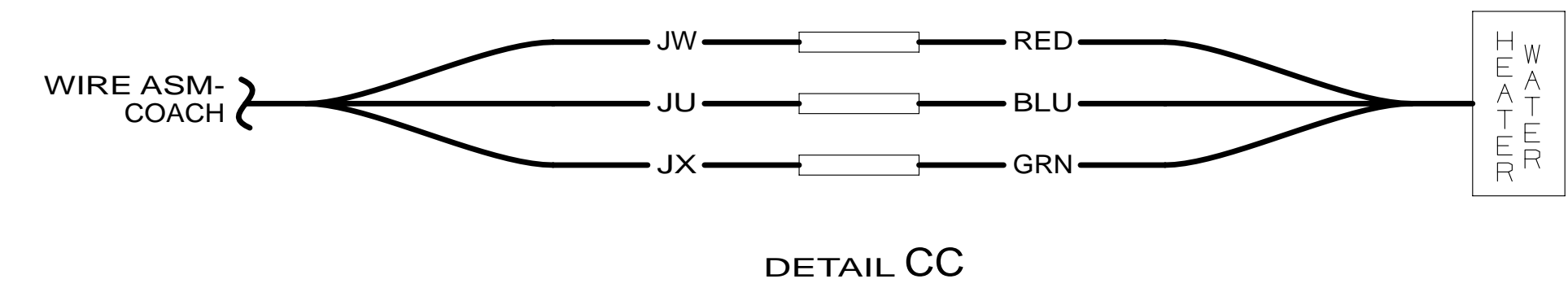

FOR ELECTRICAL TORQUE SPECIFICATIONS SEE DWG NO. 128783-01-000

FOR ELECTRICAL CALLOUTS SEE DWG NO. 121339-01-000

| | |
|------------------------------|---------------------------|
| 265 | CODES/STANDARDS-CSA/CMVSS |
| 1B1 | CODES/STANDARDS USA |
| 1B1 | 265 |
| FIRST USED | |
| 14 E26HE | |
| DO NOT SCALE DRAWING | |
| WIRING INSTL-BODY,12V | |
| SHEET 3 | PART NO 185187 REV |
| 09-Jul-2014 | |

* 185187 *

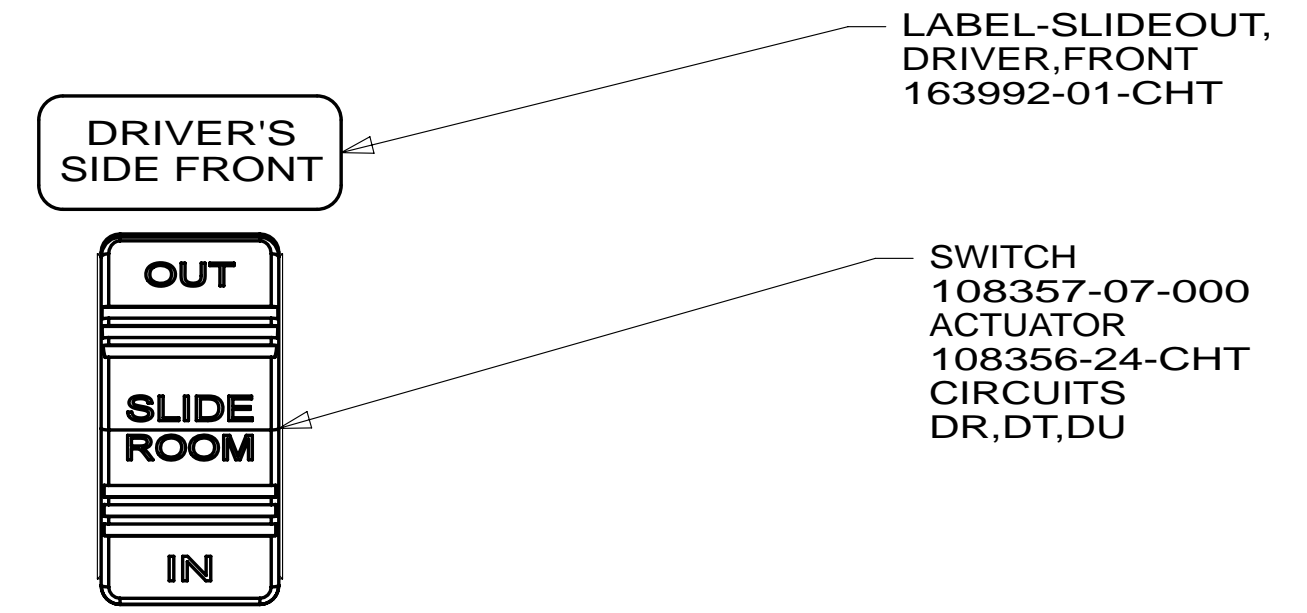

WARNING CRUSH HAZARD. Keep people and objects clear of the inside and the outside of the slideout room when operating. Failure to comply could result in death or serious injury.

DETAIL DA

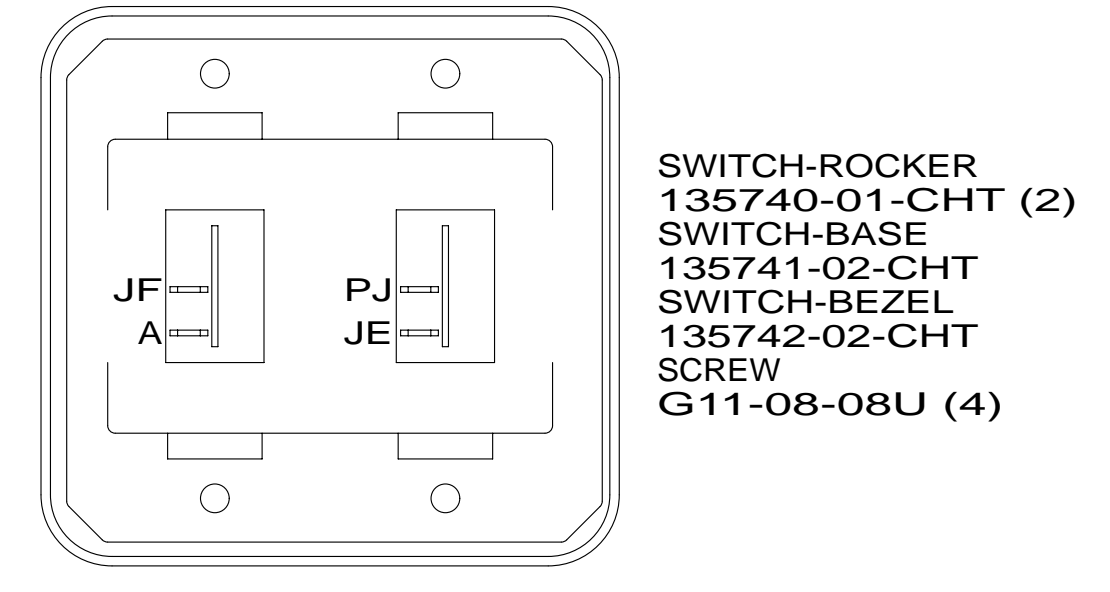

DETAIL DC

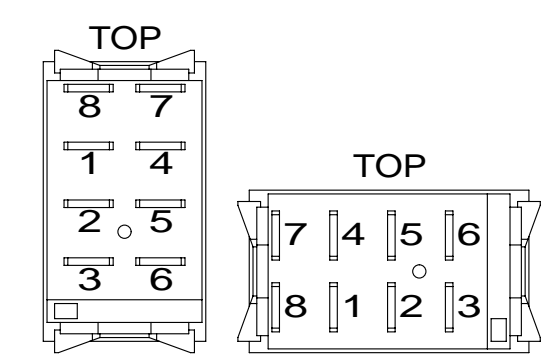

DETAIL DD

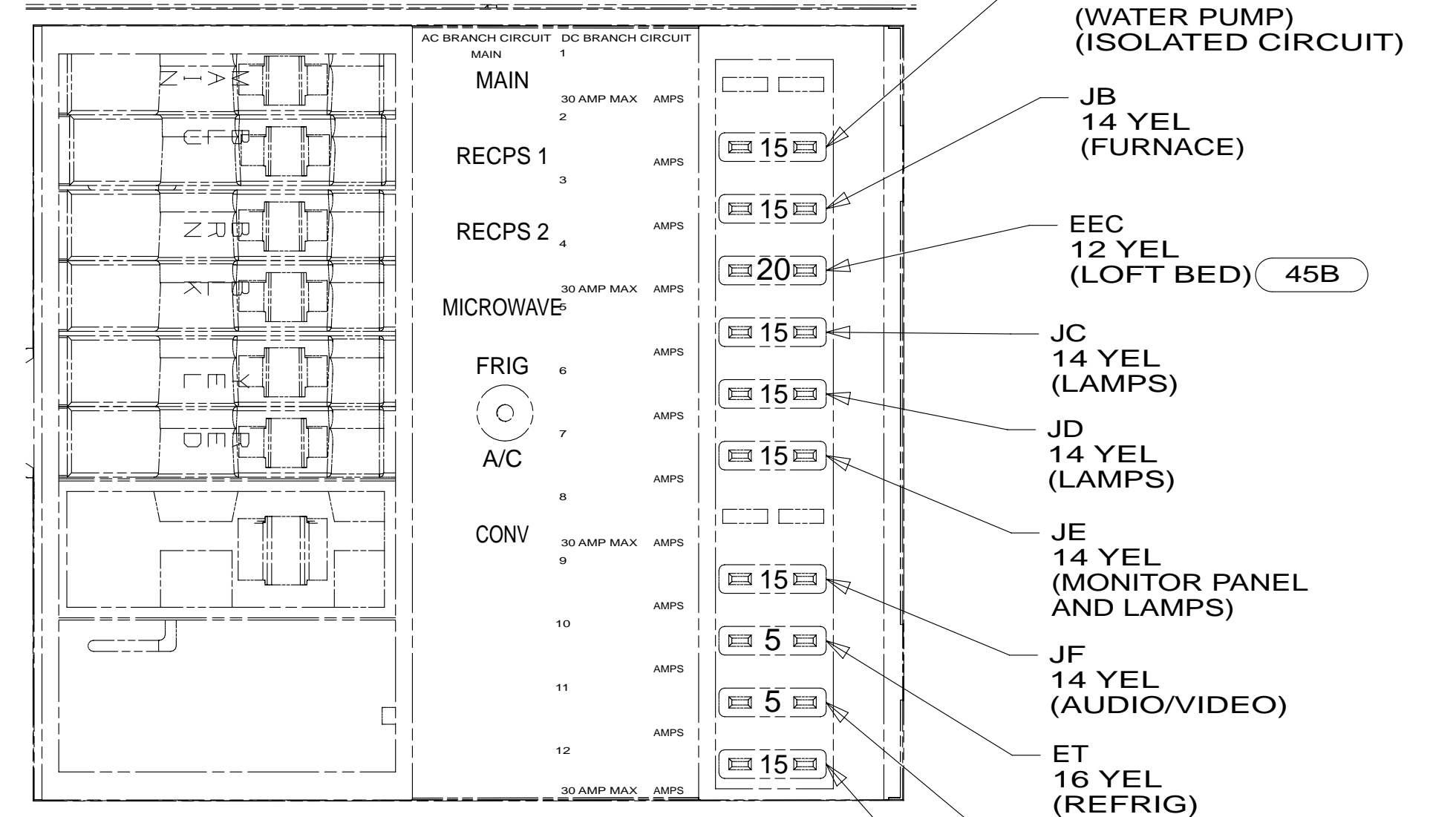

DETAIL DH

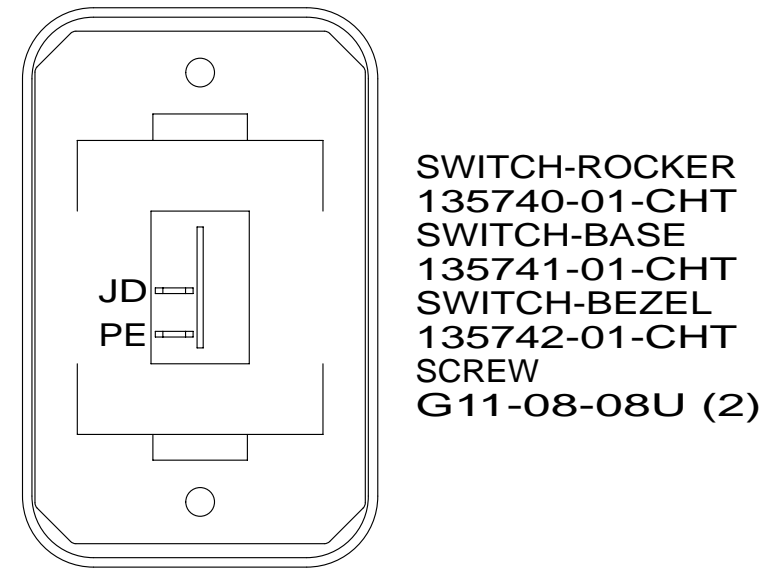

DETAIL DE

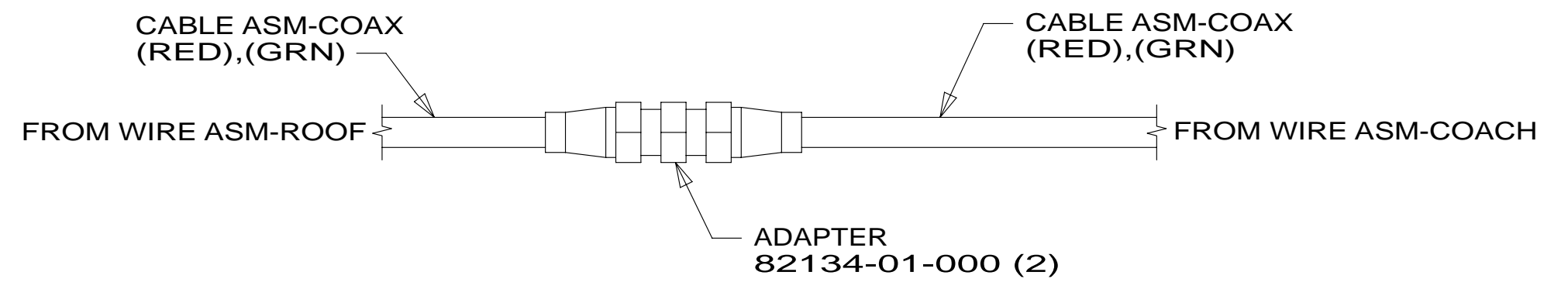

DETAIL DJ

SWITCH-AWNING
108357-06-000
ACTUATOR-SWITCH
108356-12-CHT
CIRCUITS
FFD,FFR,FFE
FFE,JJR,FFD

PLATE-SWITCH
158431-10-CHT
SCREW
G11-06-10U (6)

SWITCH-COACH BATTERY
108357-18-000
ACTUATOR-SWITCH
108356-19-CHT
CIRCUITS
KF,LG,LJ,LH,WC
WIRE ASM-THERM
186796-01-000

SWITCH-STEP
108357-19-000
CIRCUITS ER,ES

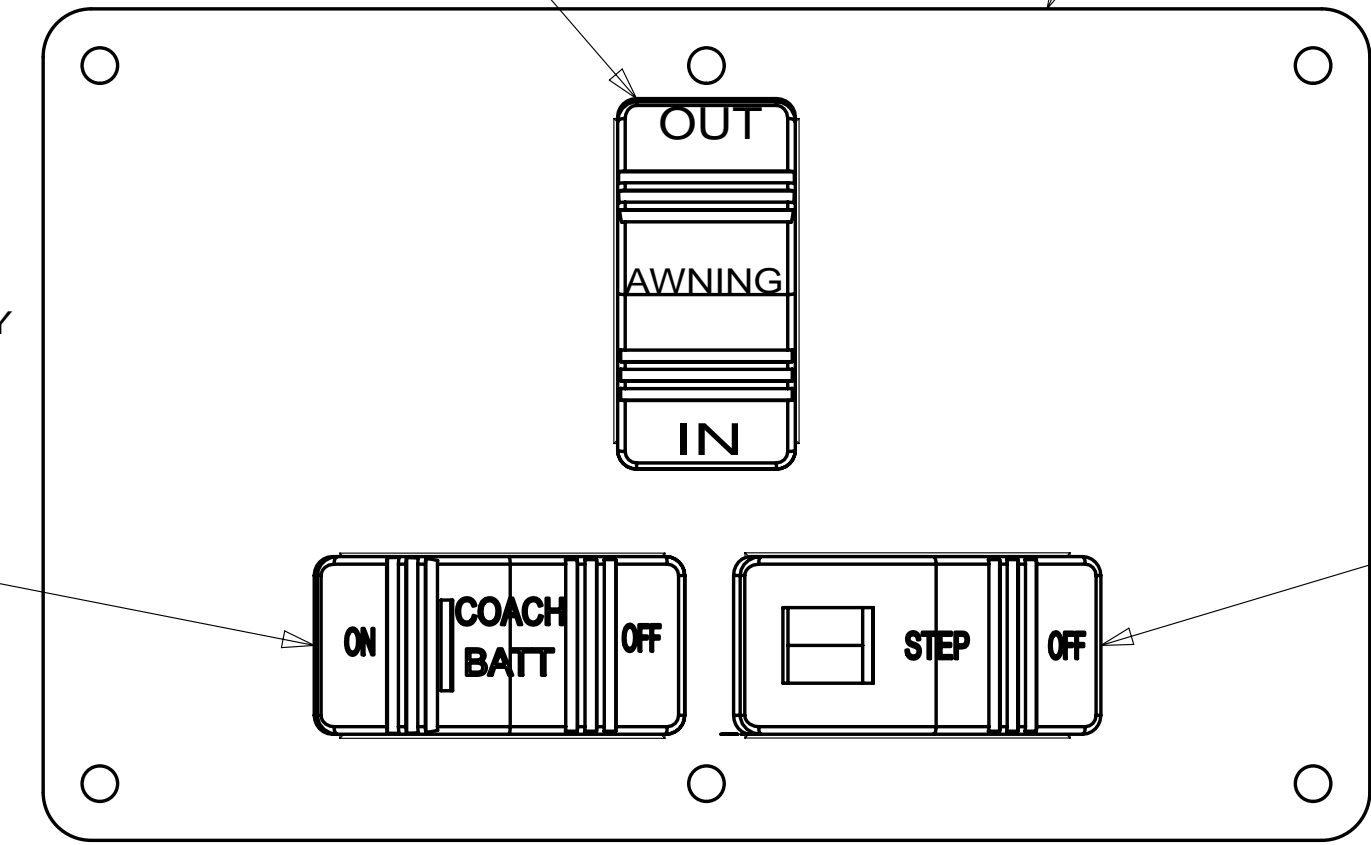

DETAIL DB 1

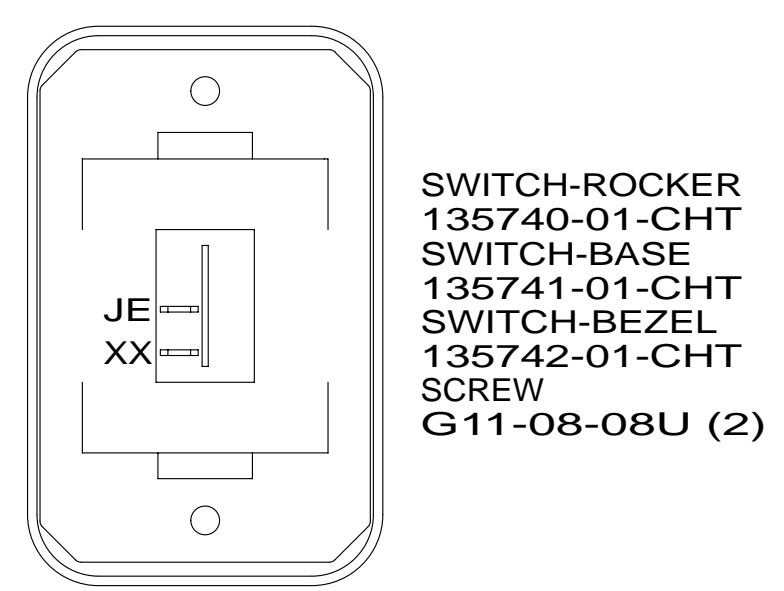

DETAIL DF

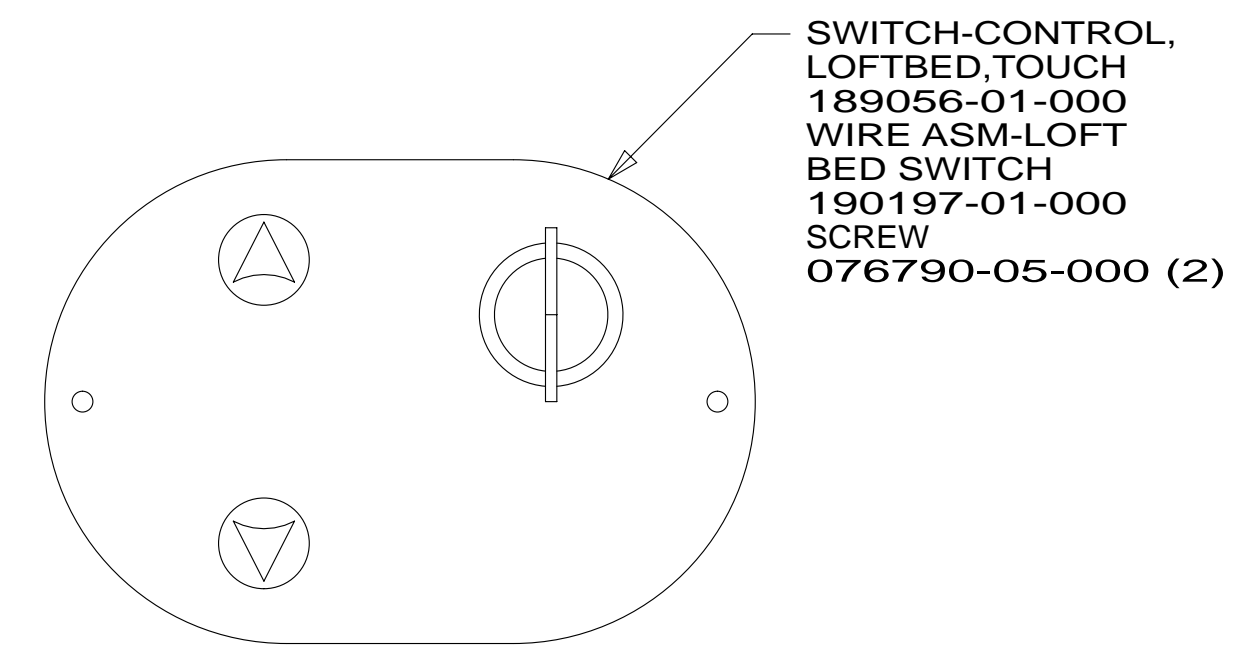

DETAIL DG 45B

- 45B LOFT BED
- 265 CODES/STANDARDS-CSA/CMVSS
- 1B1 CODES/STANDARDS USA

| | |
|-------------------------------------|---------------------|
| 1B1 | 265 |
| FIRST USED | |
| 14 E26HE | |
| DO NOT SCALE DRAWING | |
| TITLE: WIRING INSTL-BODY,12V | |
| SHEET 4 | PART NO. 185187 REV |

FOR ELECTRICAL TORQUE SPECIFICATIONS SEE DWG NO. 128783-01-000

FOR ELECTRICAL CALLOUTS SEE DWG NO. 121339-01-000

NOTES: 1 FOR SWITCH ORIENTATION SEE DETAIL DD.

* 185187 * A

8

7

6

5

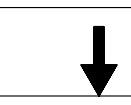

4

3

2

1

D

D

C

C



B

B

A

A

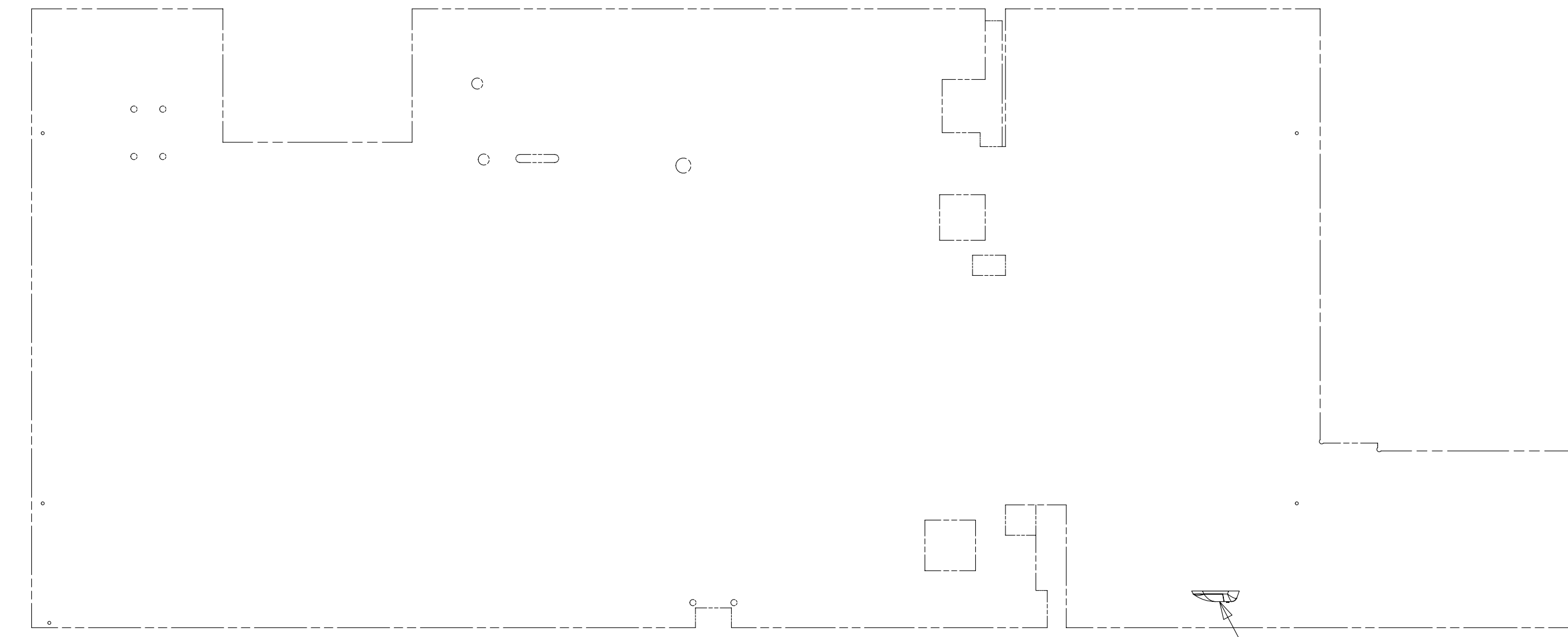
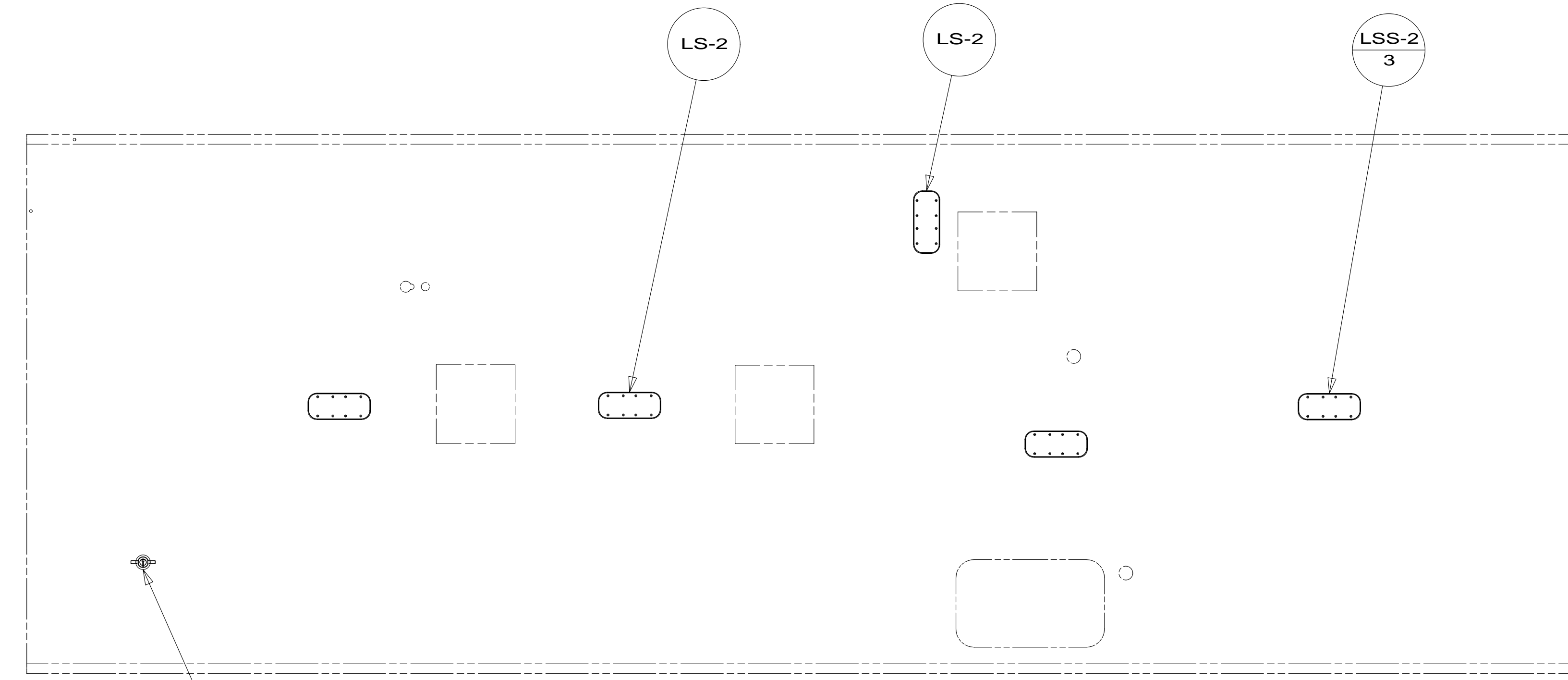

- 45B LOFT BED
- 265 CODES/STANDARDS-CSA/CMVSS
- 1B1 CODES/STANDARDS USA

1B1 265

FIRST USED **14 E26HE**

DO NOT SCALE DRAWING

TITLE: **WIRING INSTL-BODY,12V**

SHEET 5 PART NO **185187** REV

FOR ELECTRICAL TORQUE SPECIFICATIONS SEE DWG NO. 128783-01-000

FOR ELECTRICAL CALLOUTS SEE DWG NO. 121339-01-000

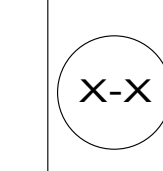

8

7

6

5



4

3

2

1

* 185187 * A

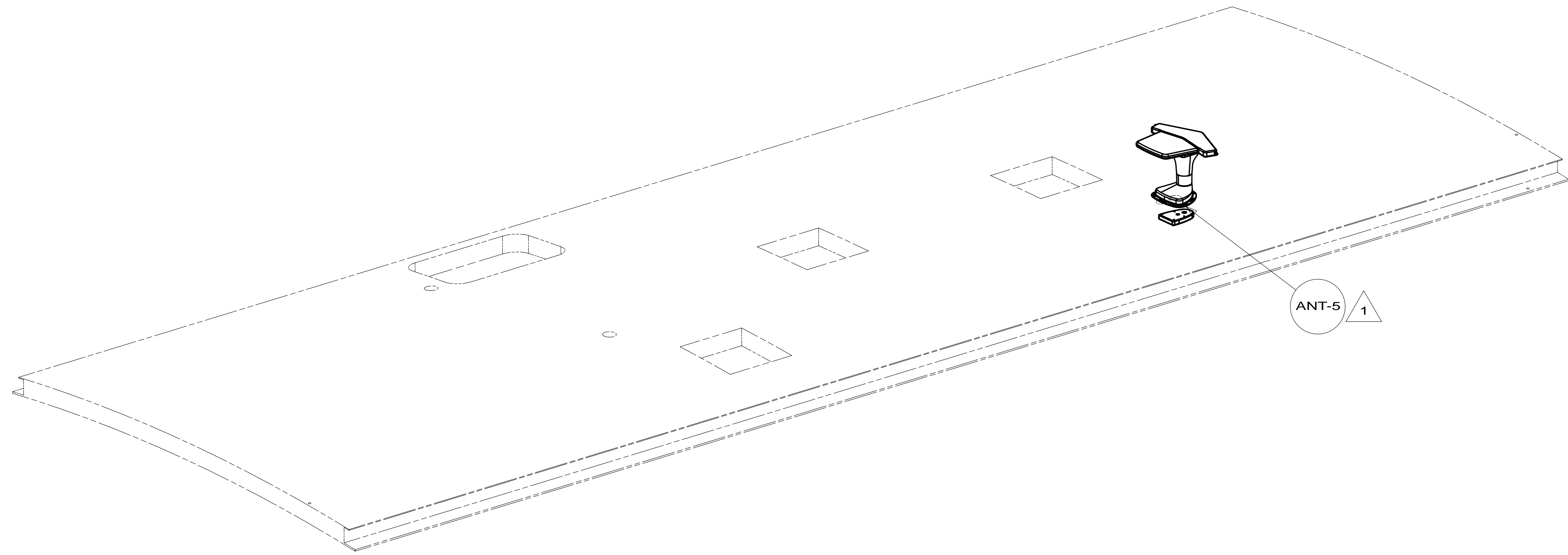

1 SEE ANTENNA INSTALLATION MANUAL FOR CORRECT INSTALLATION PROCEDURE.

NOTES:

FOR ELECTRICAL TORQUE SPECIFICATIONS SEE DWG NO. 128783-01-000

FOR ELECTRICAL CALLOUTS SEE DWG NO. 121339-01-000

265 CODES/STANDARDS-CSA/CMVSS

1B1 CODES/STANDARDS USA

1B1 265

FIRST USED 14 E26HE

DO NOT SCALE DRAWING

TITLE: WIRING INSTL-BODY,12V

SHEET 6 PART NO 185187 REV

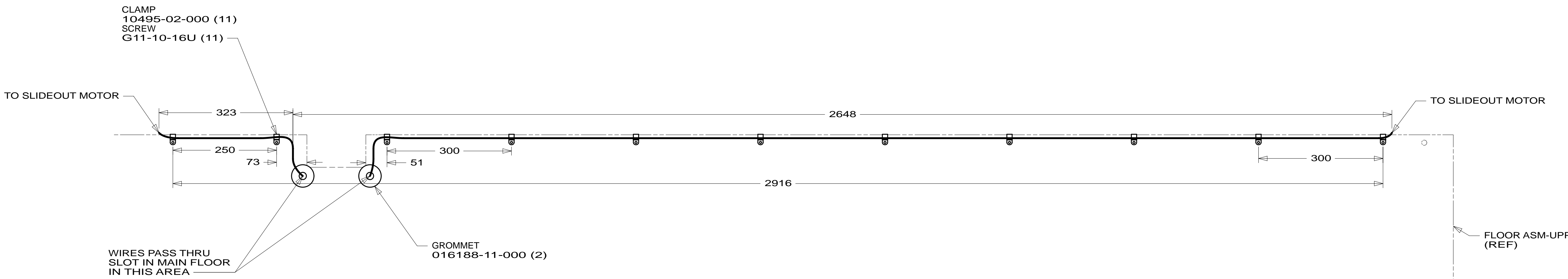

VIEW GA
(FRONT LEFT)

265 CODES/STANDARDS-CSA/CMVSS

1B1 CODES/STANDARDS USA

1B1 265

FIRST USED
14 E26HE

DO NOT SCALE DRAWING

TITLE:
WIRING INSTL-BODY, 12V

SHEET 7 PART NO **185187** REV

FOR ELECTRICAL
TORQUE
SPECIFICATIONS
SEE DWG NO.
128783-01-000

FOR
ELECTRICAL
CALLOUTS
SEE DWG NO.
121339-01-000

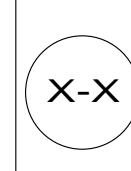

* 185187 * A