



**DANGER**

**Danger of electrical shock, burns or death.** Always remove all power sources before attempting any repair, service or diagnostic work. Power can be present from shore power, generator, inverter or battery. All power sources must be disabled and secured before performing any service.



**CAUTION**

If you lack the skills, tools or equipment to perform diagnostic or repair work leave such work to an authorized Winnebago Industries dealer or other qualified shop.

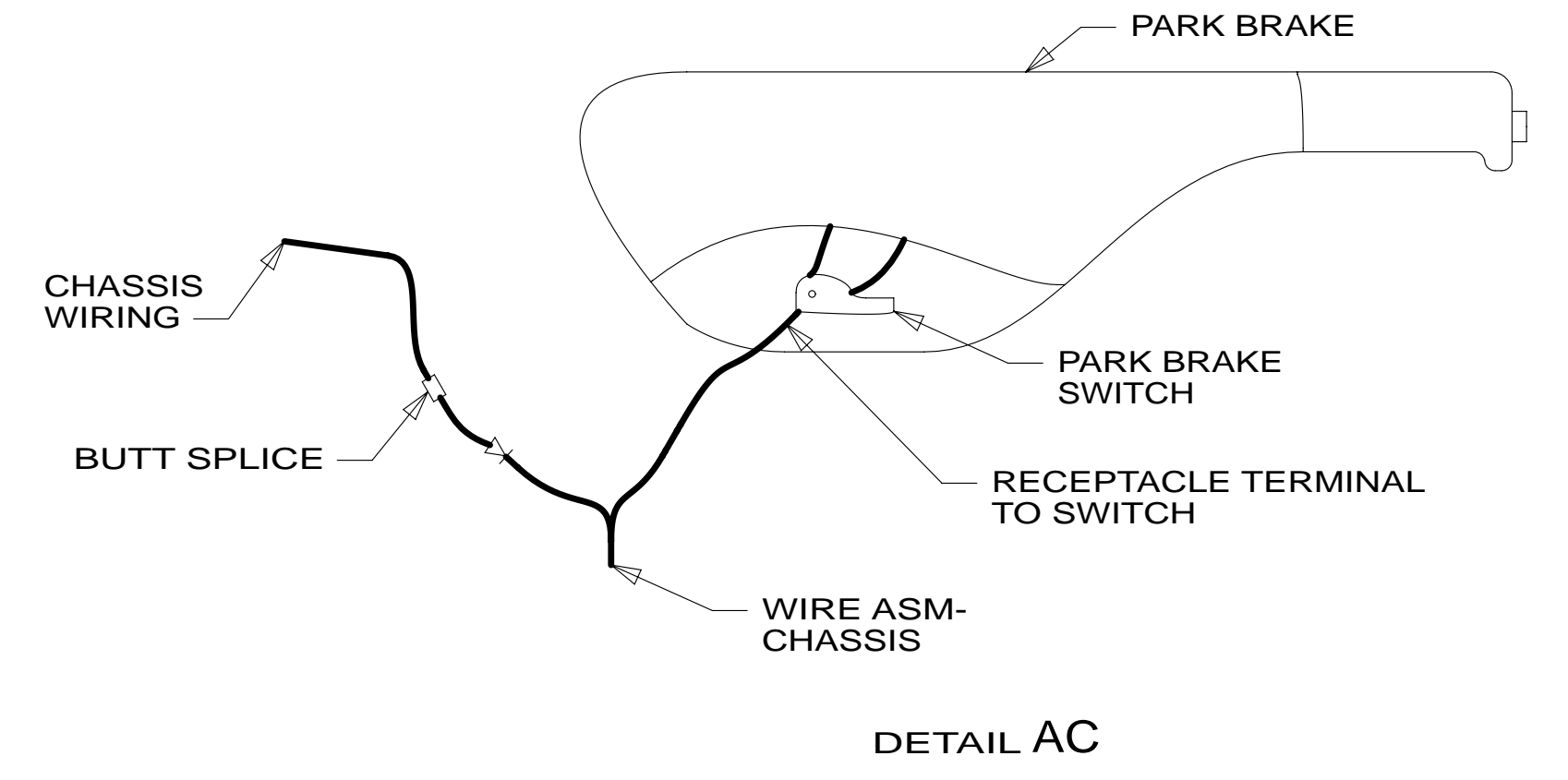
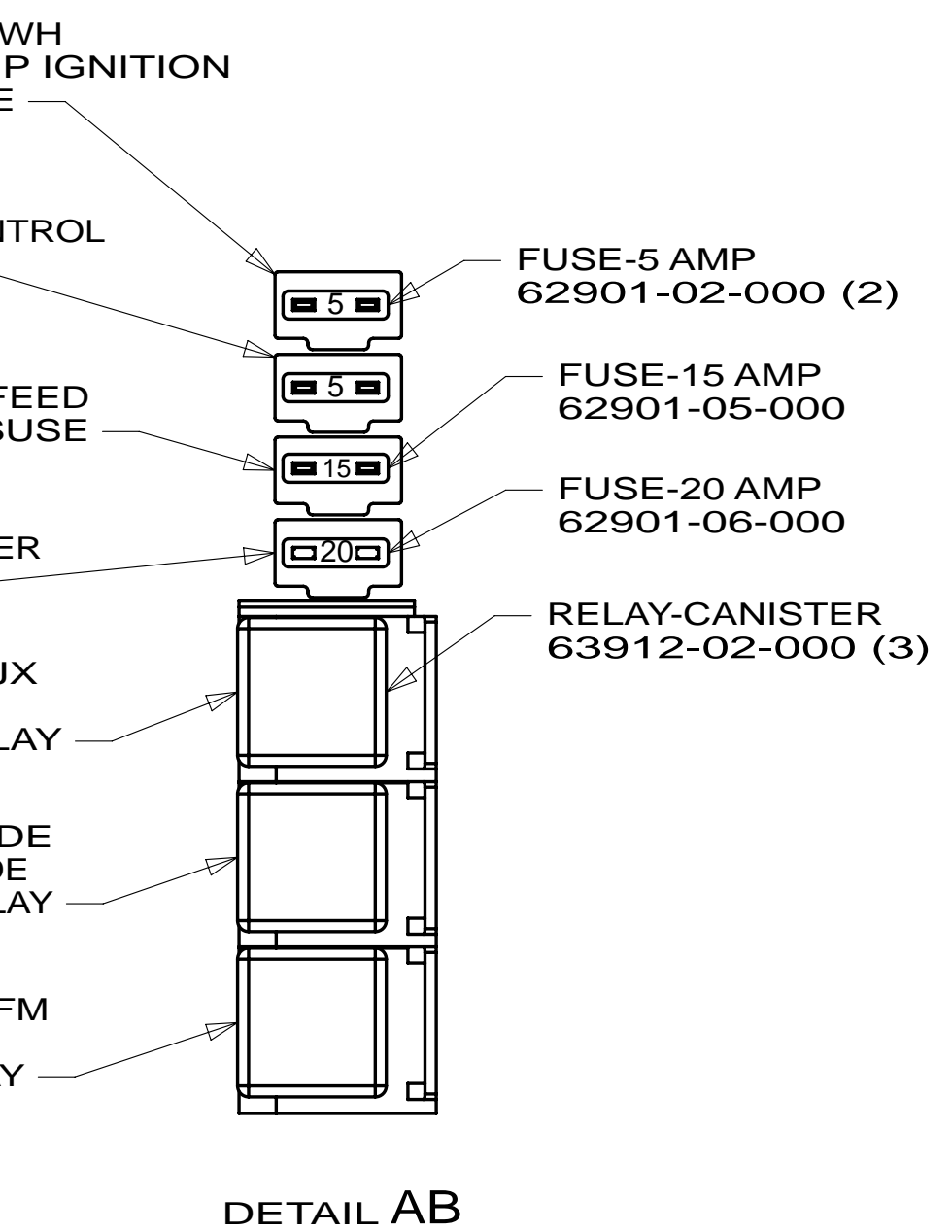
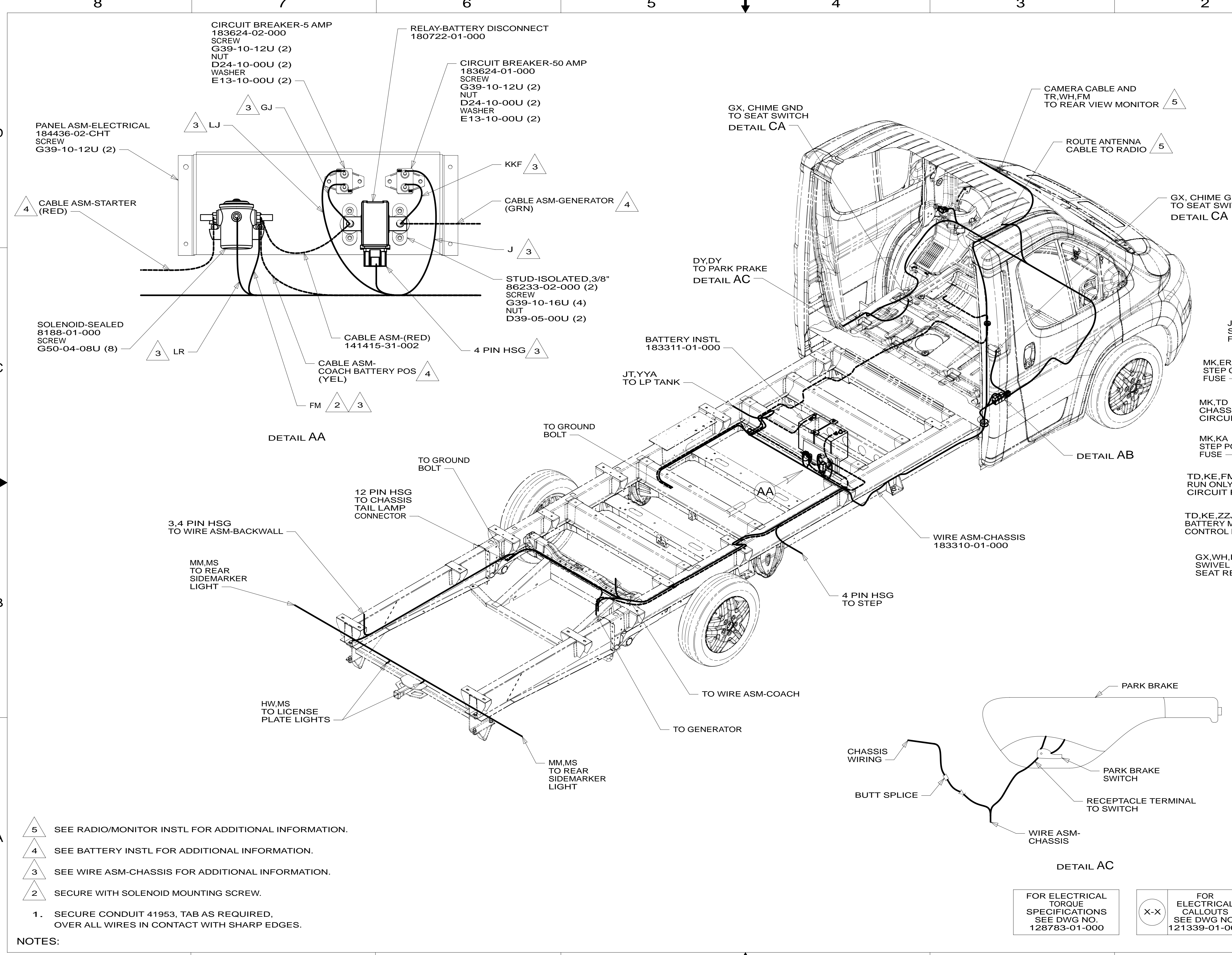

- NOTES:
- 5 SEE RADIO/MONITOR INSTL FOR ADDITIONAL INFORMATION.
  - 4 SEE BATTERY INSTL FOR ADDITIONAL INFORMATION.
  - 3 SEE WIRE ASM-CHASSIS FOR ADDITIONAL INFORMATION.
  - 2 SECURE WITH SOLENOID MOUNTING SCREW.
  - 1. SECURE CONDUIT 41953, TAB AS REQUIRED, OVER ALL WIRES IN CONTACT WITH SHARP EDGES.

FOR ELECTRICAL TORQUE SPECIFICATIONS SEE DWG NO. 128783-01-000

X-X FOR ELECTRICAL CALLOUTS SEE DWG NO. 121339-01-000

265 CODES/STANDARDS-CSA/CMVSS  
 1B1 CODES/STANDARDS USA  
 1B1 265 1ME

**WINNEBAGO** COPYRIGHT 2014 WINNEBAGO INDUSTRIES, INC.

DFTR	ORIG. DATE
CHKR	ALL DIMENSIONS ARE IN MILLIMETERS
P.E.	FIRST USED
M.E.	14 623L
DSNR	

UNSPECIFIED TOLERANCES ARE:  
 WHOLE DIM (X) : 3  
 ONE-PLACE (X.X) : 1.5  
 TWO-PLACE (X.XX) : 0.50  
 ANGLE : 1°

THIRD ANGLE PROJECTION

DO NOT SCALE DRAWING REFER TO ES0018 FOR FASTENER TIGHTENING GUIDELINES

TITLE: **WIRING INSTL-CHASSIS**

SHEET 1 OF 3 PART NO. 183312 REV 1

REF: 1 25-Mar-2014

\* 183312 \*



8

7

6

5

4

3

2

1

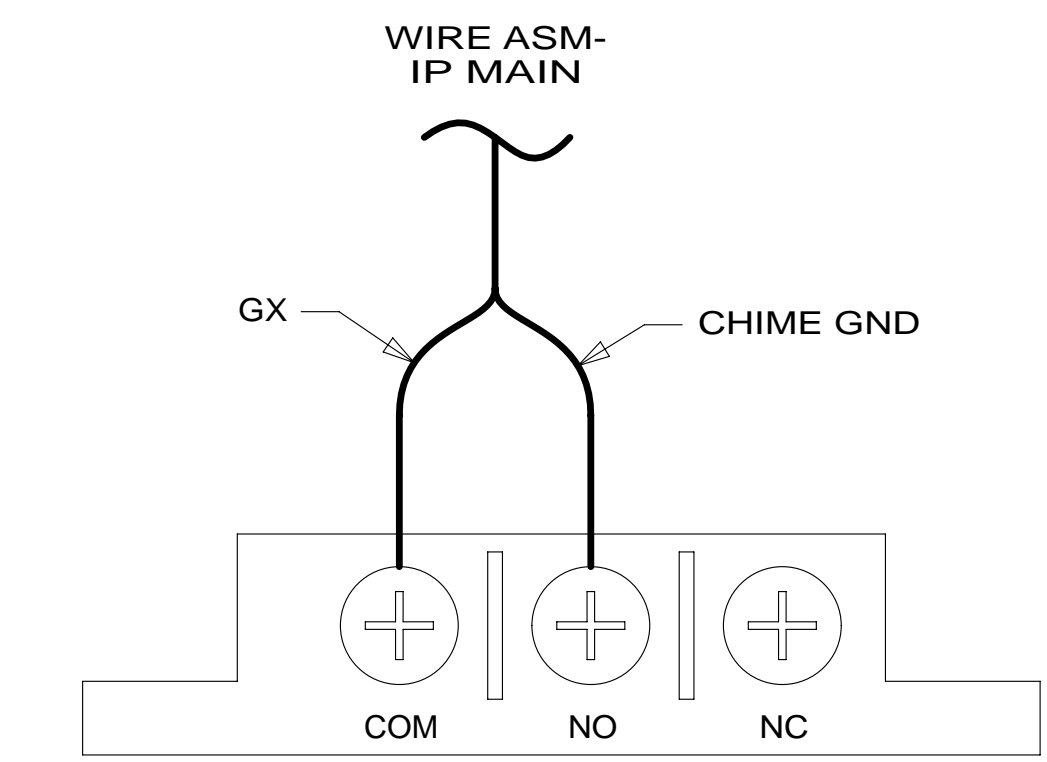
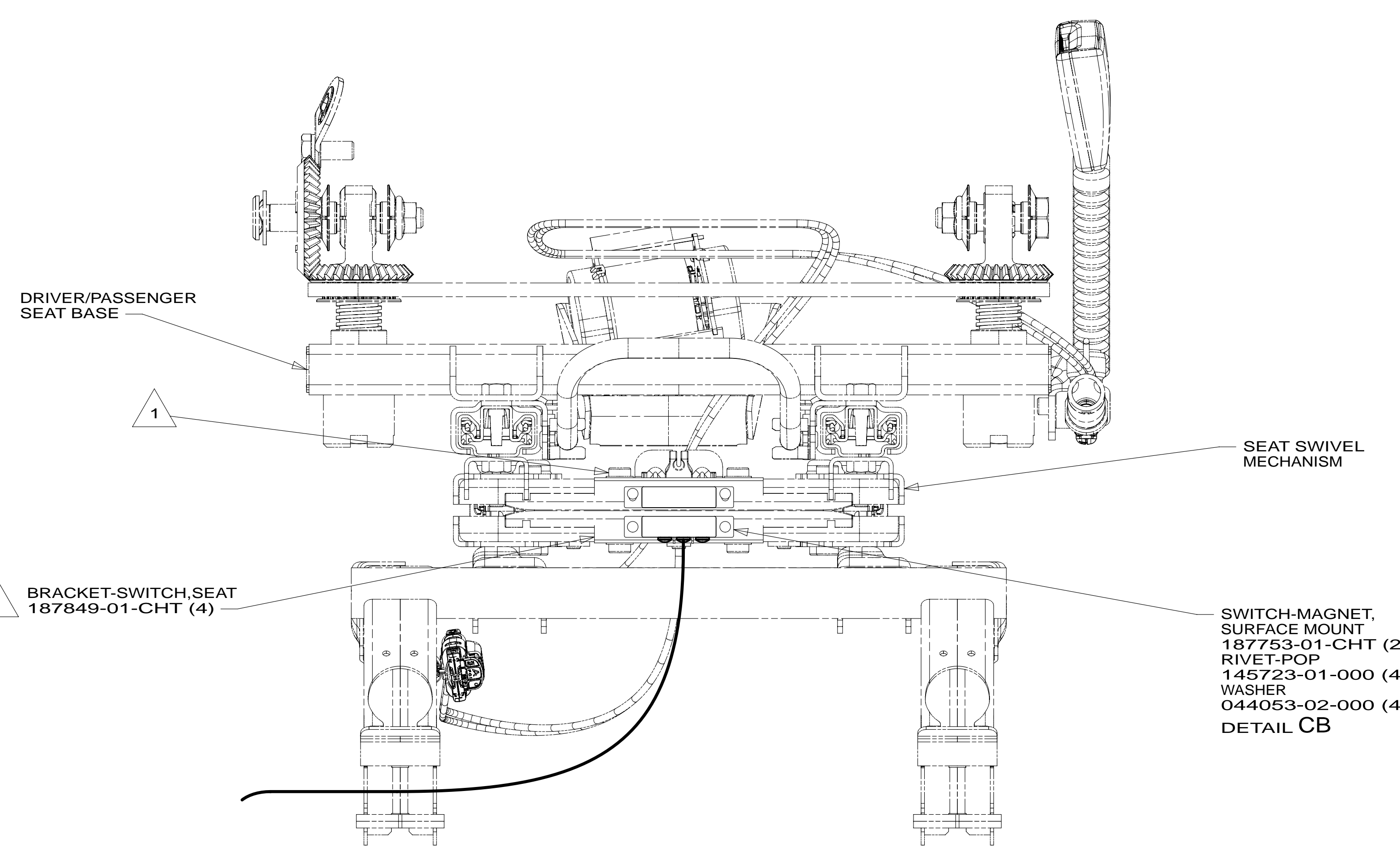

DETAIL CB

DETAIL CA

- NOTES:
- 2 INSTALL ON BOTH THE DRIVER AND PASSENGER SEATS.
  - 1 MOUNT BRACKETS TO SEAT SWIVEL MECHANISM BY LOOSENING BOLTS ON BOTH TOP AND BOTTOM OF MECHANISM.

FOR ELECTRICAL TORQUE SPECIFICATIONS SEE DWG NO. 128783-01-000

FOR ELECTRICAL CALLOUTS SEE DWG NO. 121339-01-000

- 265 CODES/STANDARDS-CSA/CMVSS
- 1B1 CODES/STANDARDS USA

1B1 265

FIRST USED	<b>14 623L</b>	
TITLE:	<b>DO NOT SCALE DRAWING</b>	
	<b>WIRING INSTL-CHASSIS</b>	
SHEET 3	PART NO <b>183312</b>	REV

\* 183312 \* A