

FRONT
OF
COACH

- 1B1 CODES/STANDARDS USA
- 265 CODES/STANDARDS-CSA/CMVSS
- 23T DRAINAGE SYSTEM-HEATED
- 1JD DRAINAGE SYSTEM-HEATED-W/O
- 43E TOILET PORCELAIN-ROUND

- NOTES:
8. PREP THE SURFACE PER MANUFACTURERS INSTRUCTIONS BEFORE APPLYING THE HEATING PAD.
 7. USE SMOOTH PLUMBERS PUTTY 167459-01-000 TO SEAL STRAINER (.2 PER STAINER)
 6. VENT PIPE MUST PROJECT 51 MIN AND 64 MAX ABOVE ROOF FOR PROPER FIT AND FUNCTION.
 5. SEAL AROUND SHOWER WITH SILICONE.
 4. SECURE VENT PIPE TO FLOOR WITH CLAMP 062401-02-000 (2), SCREW 000G67-10-12B (2), BRACKET 136878-01-CHT (2).
 3. ALL PIPE AND FITTINGS TO BE ASSEMBLED WITH SOLVENT 004020-01-000 (USA), 004020-02-000 (CAN)
 2. SLOPE OF TRAP ARM MUST BE 6 PER 305 mm.
 1. SLOPE OF HORIZONTAL PIPING TO BE MIN 3 PER 305 mm.

FOR
DRAINAGE
CALLOUTS
SEE DWG NO
116229-01-000

WINNEBAGO		COPYRIGHT 2014 WINNEBAGO INDUSTRIES, INC.	
DFT-ORIG	ORIG. DATE	ALL DIMENSIONS ARE IN MILLIMETERS	
CHKR			
P.E.			
M.E.	FIRST USED	13 524J	
DSNR			
UNSPECIFIED TOLERANCES ARE:		MATERIAL:	
WHOLE DIM (X)	: 3		
ONE-PLACE (X.X)	: 1.5		
TWO-PLACE (X.XX)	: 0.50		
ANGLE	: 1°		
THIRD ANGLE PROJECTION		REFER TO ES0018 FOR FASTENER TIGHTENING GUIDELINES	
DO NOT SCALE DRAWING		TITLE: DRAINAGE SYSTEM INSTL	
SHEET 1 OF 4	PART NO	181846	REV
REF:	1	31-Mar-2014	

* 181846 * A

GALLEY SINK
 179864-01-CHT
 SEAL
 091255-03-000 (2130)
 STRAINER
 092303-01-000 (2)
 WASTE-TRAP
 011091-02-000

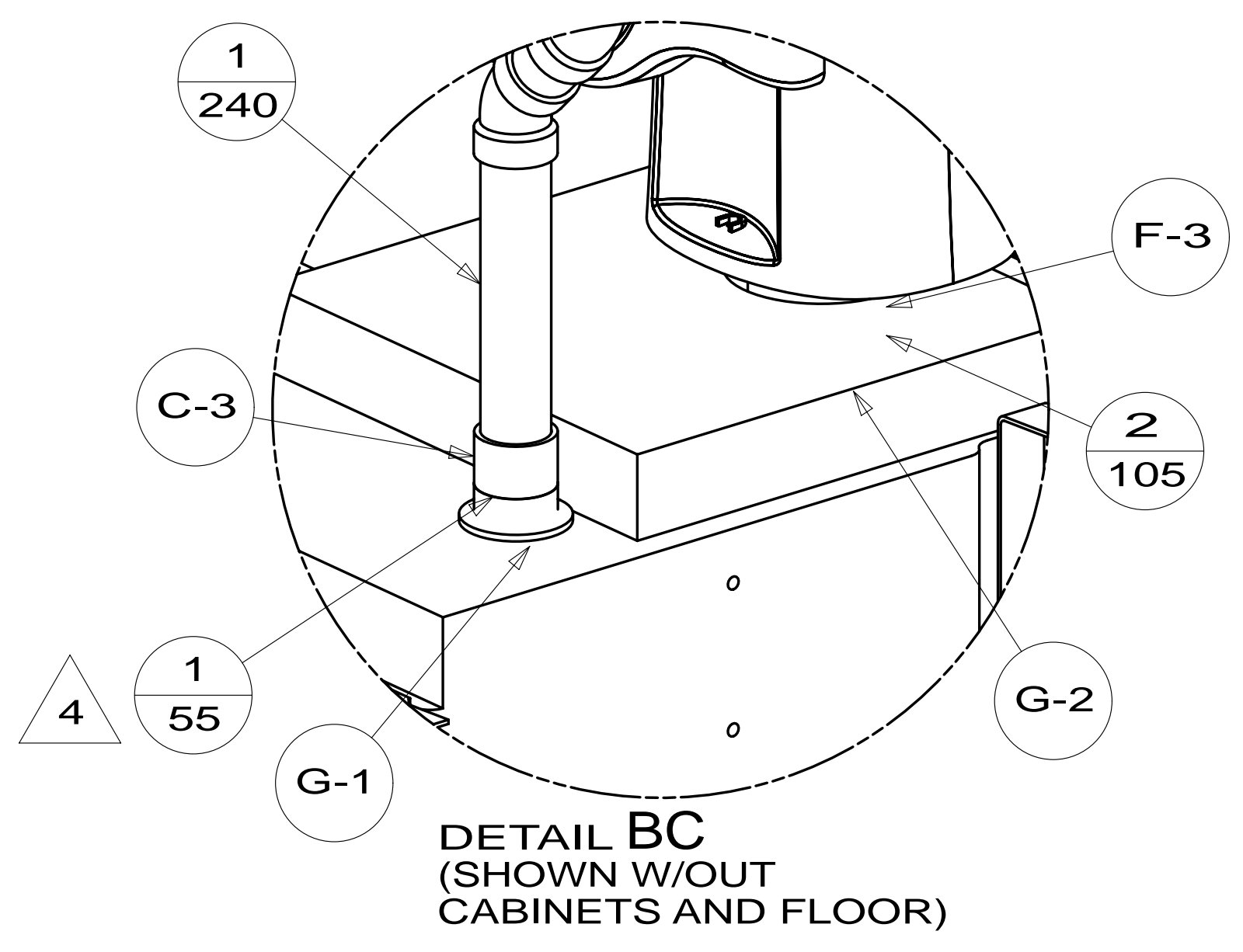
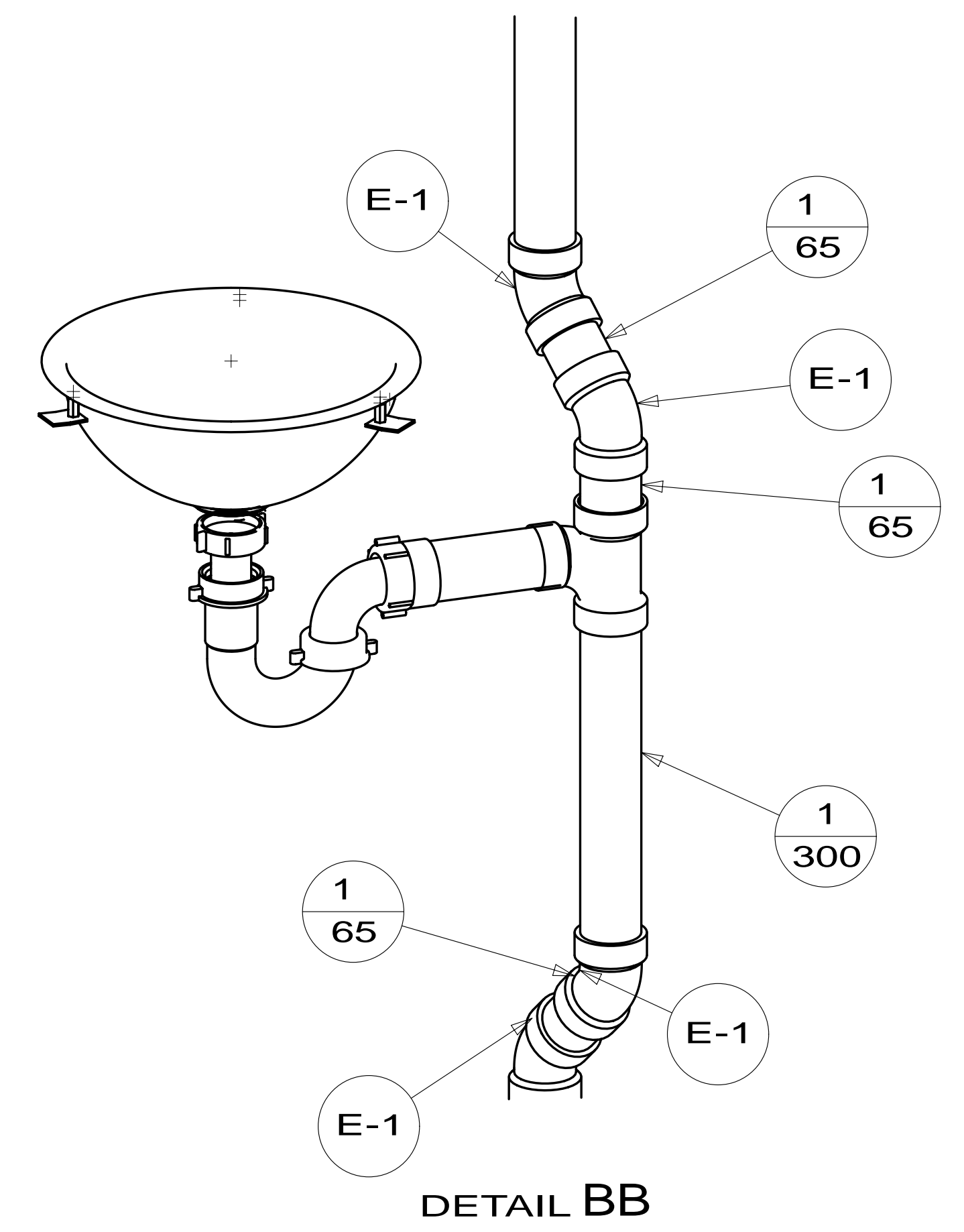
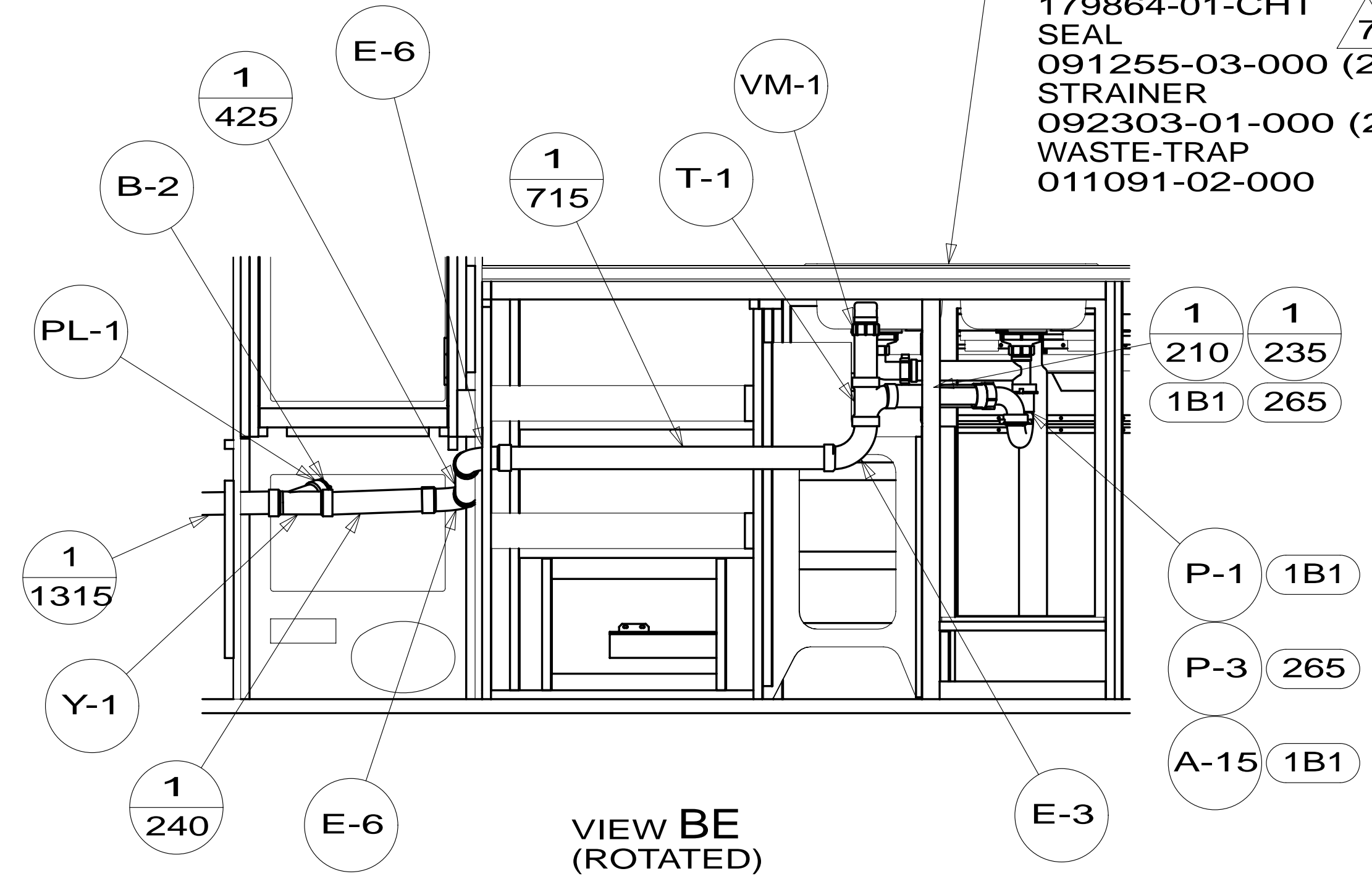
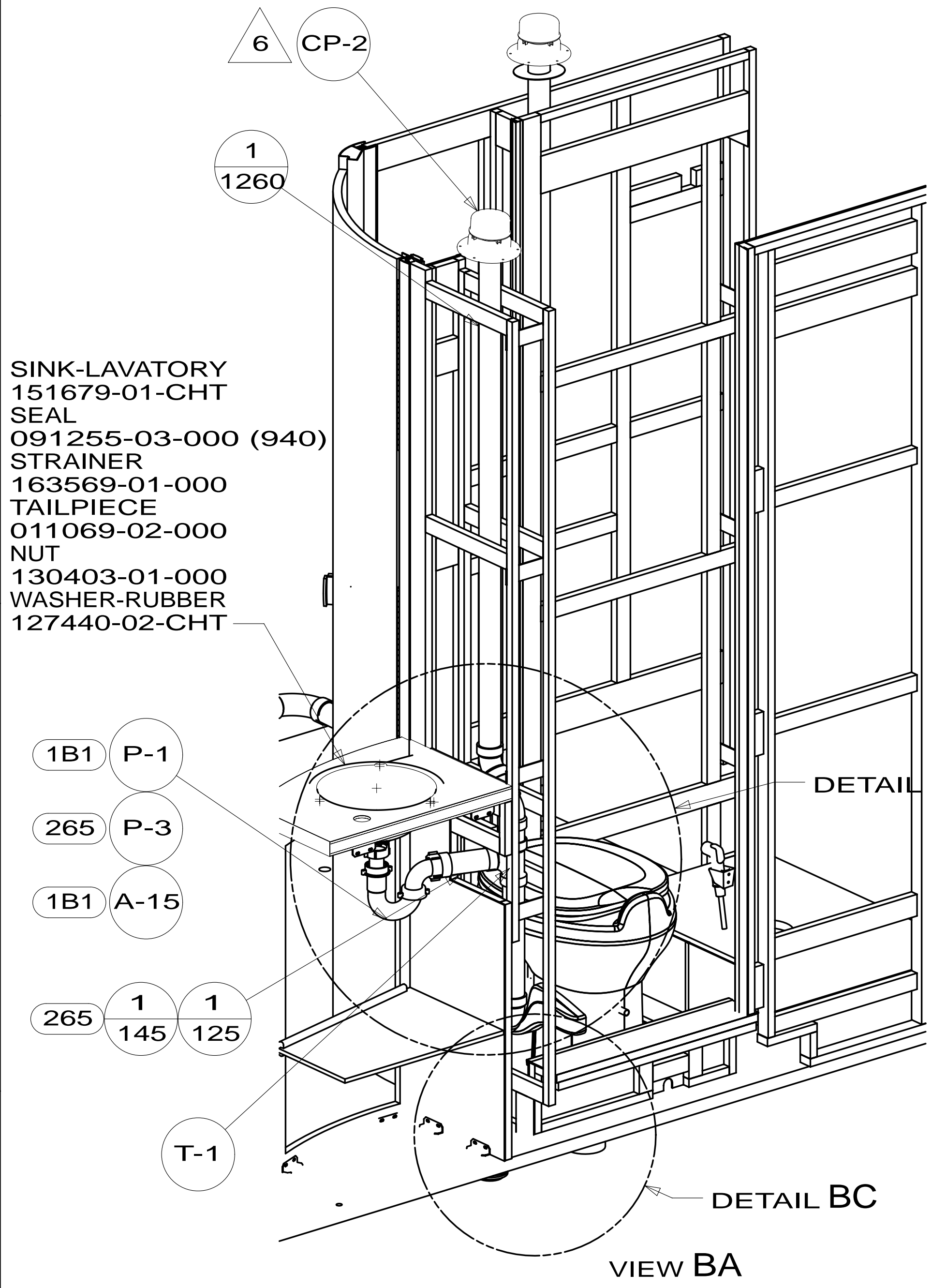

FIRST USED	13 524J		
TITLE:	DO NOT SCALE DRAWING		
TITLE:	DRAINAGE SYSTEM INSTL		
SHEET 2	PART NO	181846	REV
			31-Mar-2014

* 181846 * A

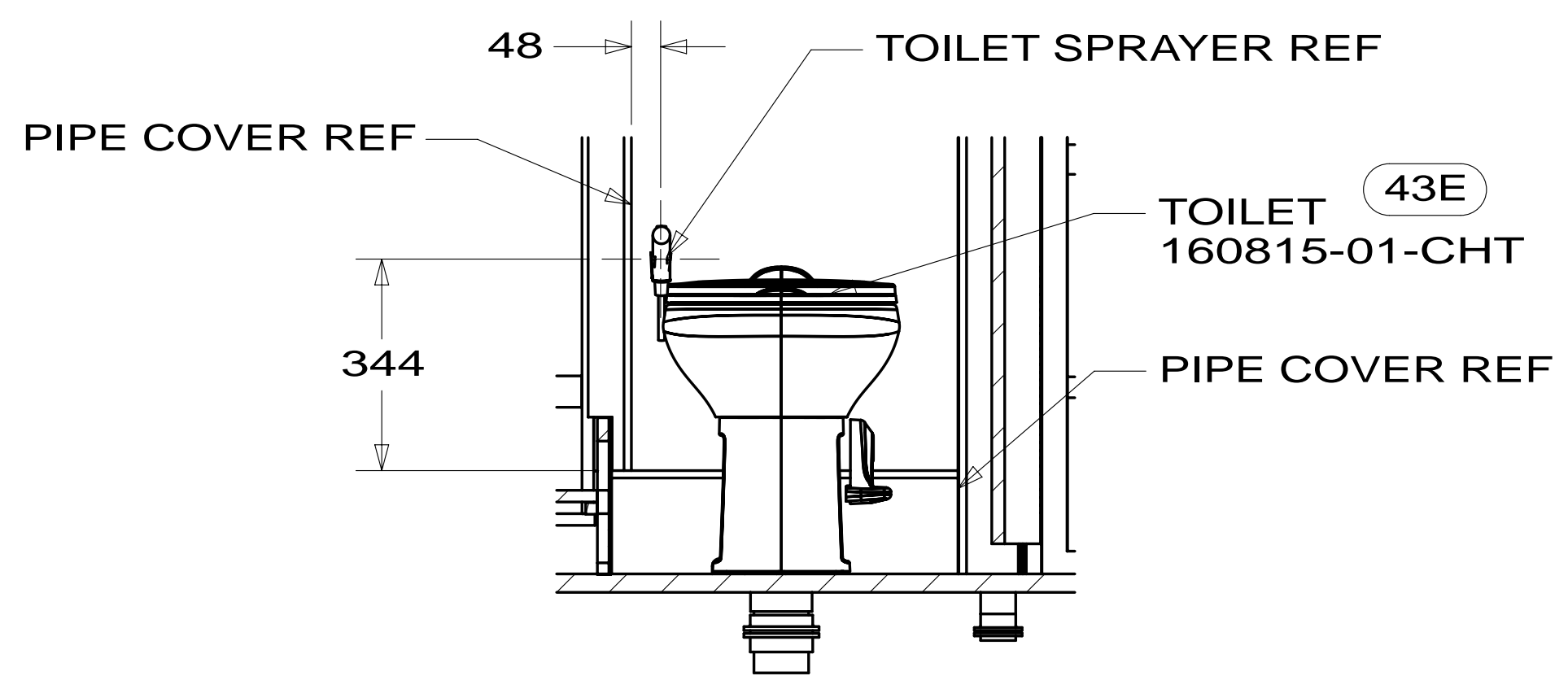

SECTION DC-DC

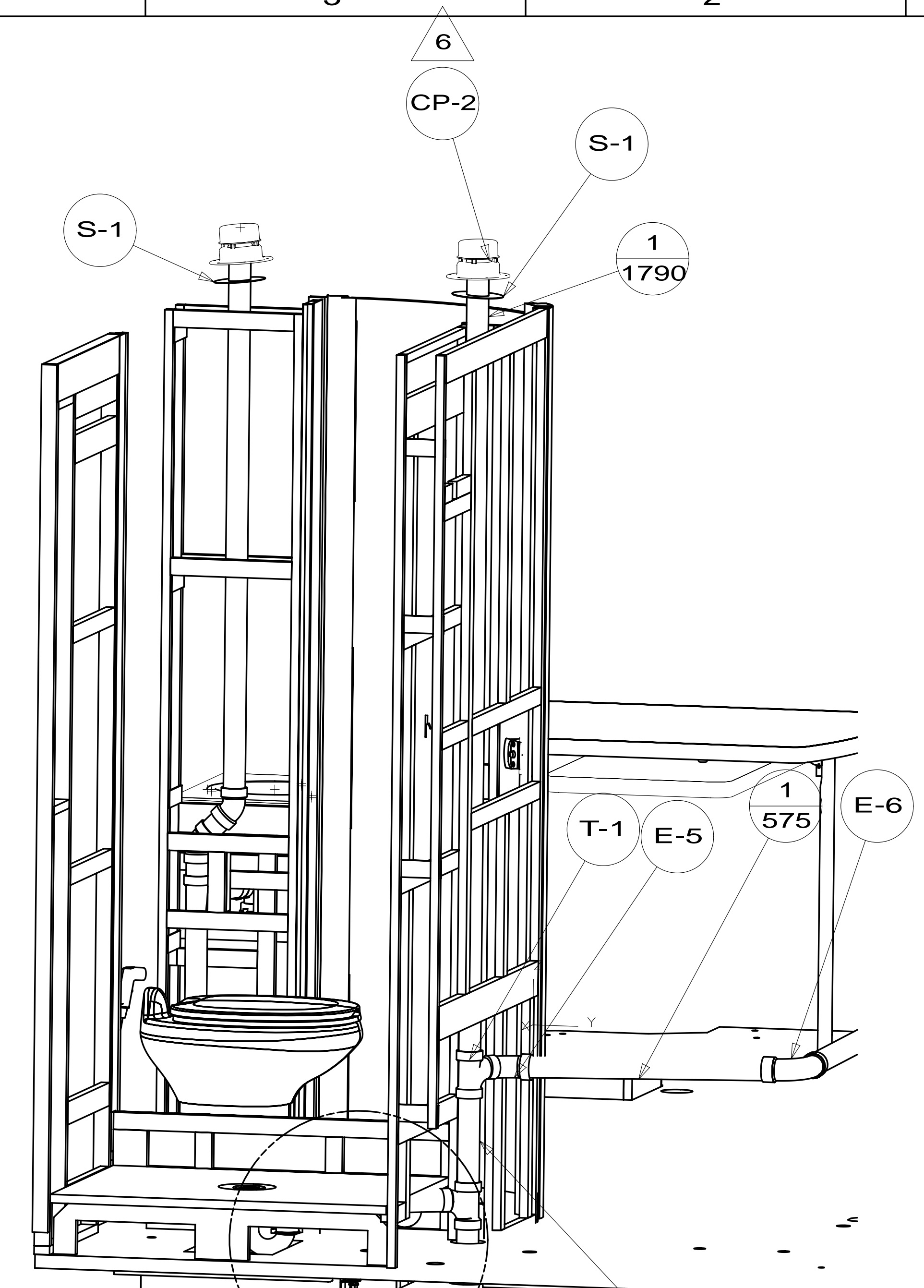

DETAIL DB

VIEW DA

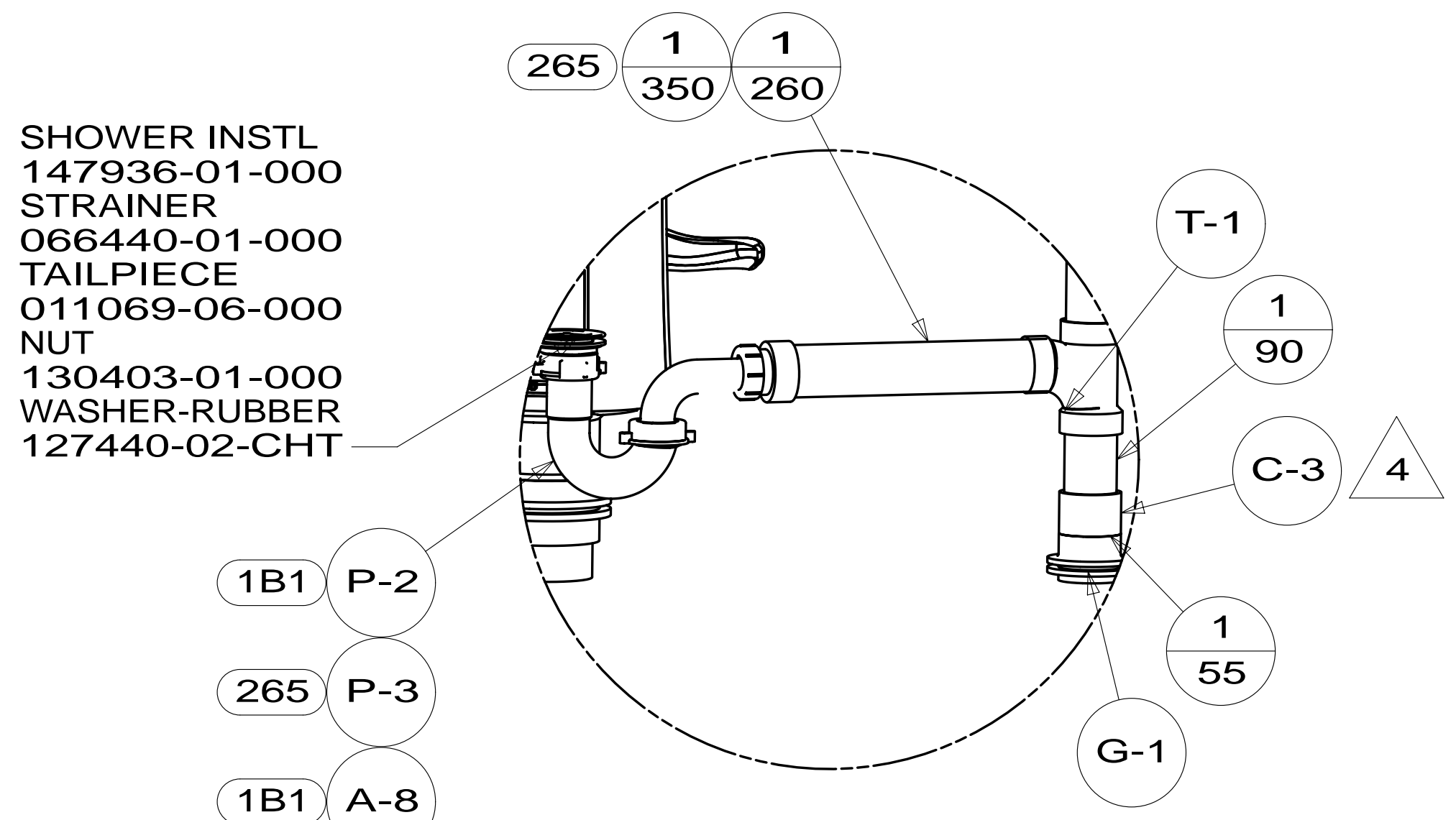

DETAIL DB
(SHOWN W/OUT
CABINETS AND FLOOR)

FIRST USED	13 524J	
TITLE:	DO NOT SCALE DRAWING	
SHEET 3	PART NO	181846
	REV	
		31-Mar-2014

* 181846 * A

SHOWING TANKS AND DRAINS BELOW FLOOR

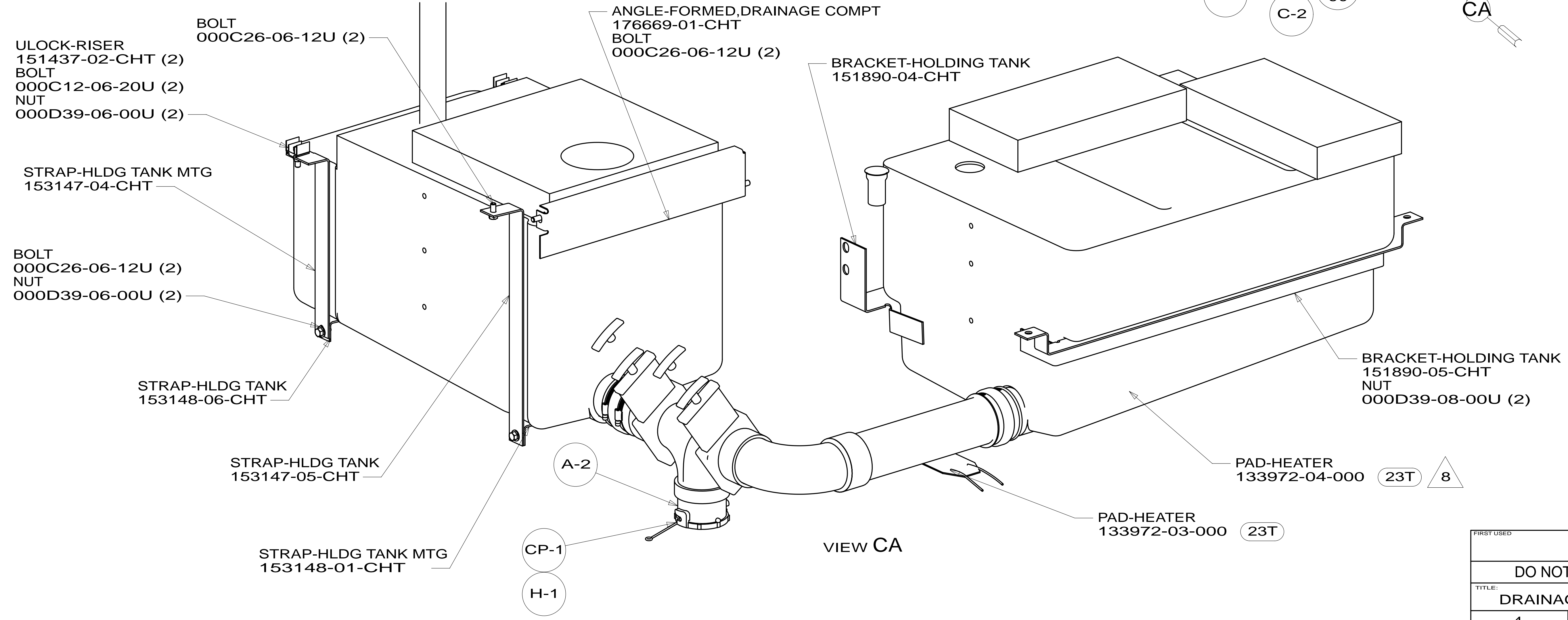
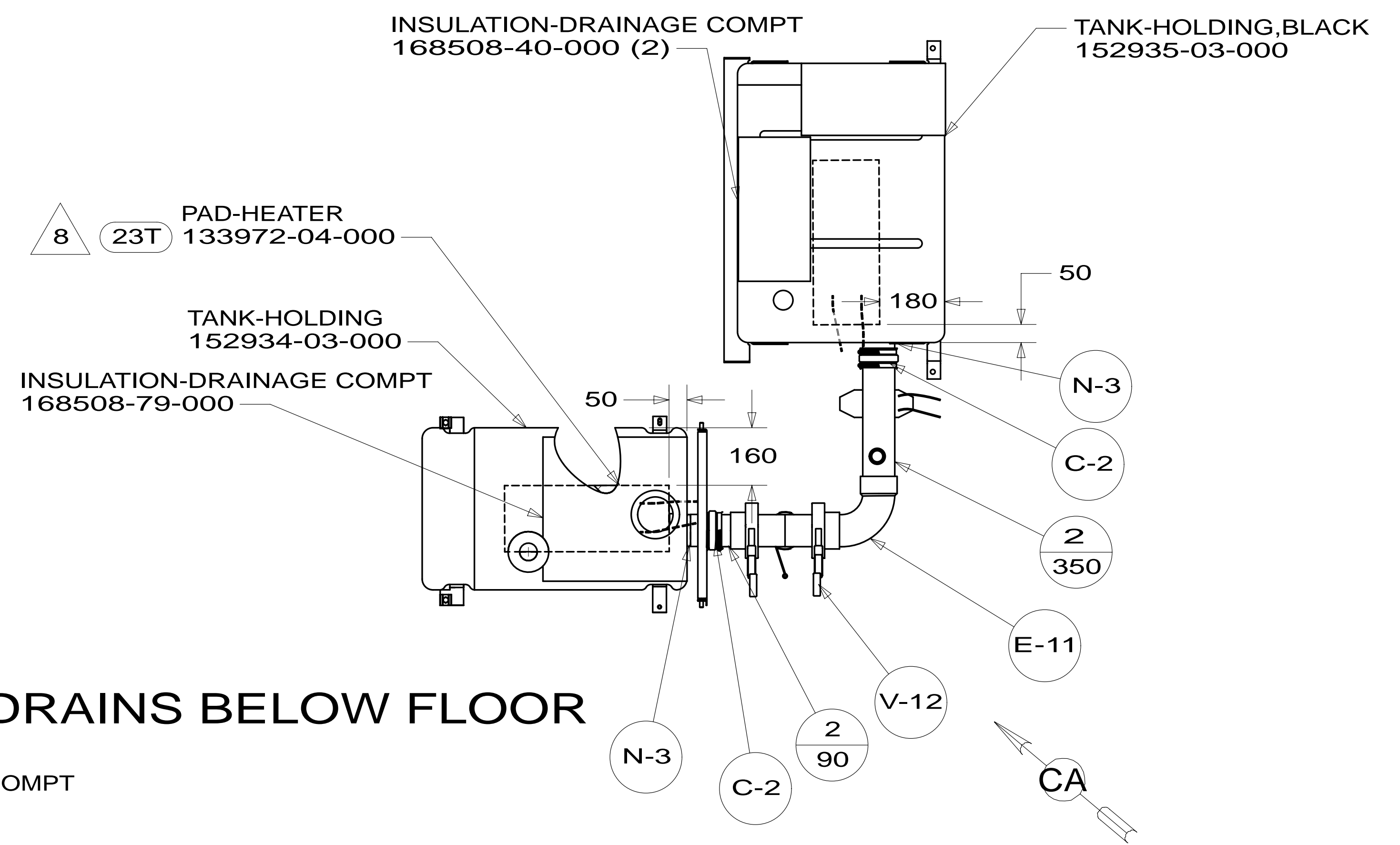

FIRST USED	13 524J	
TITLE:	DO NOT SCALE DRAWING	
SHEET 4	PART NO 181846	REV
		31-Mar-2014

* 181846 * A

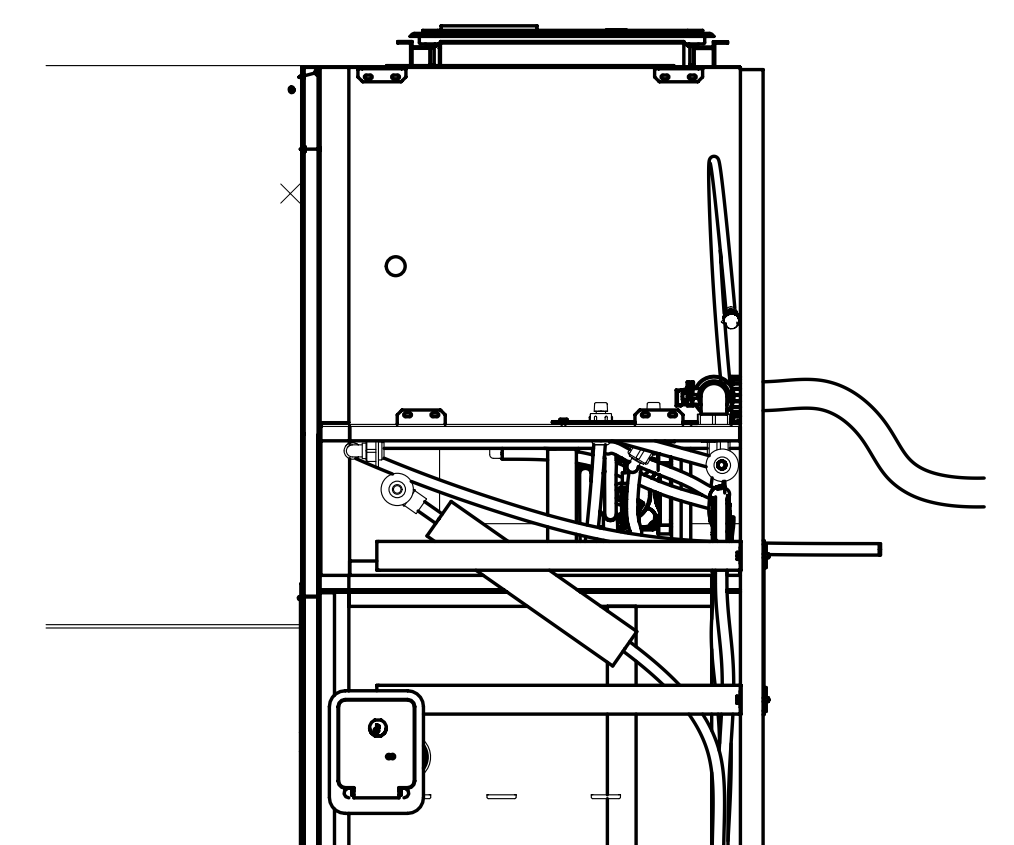
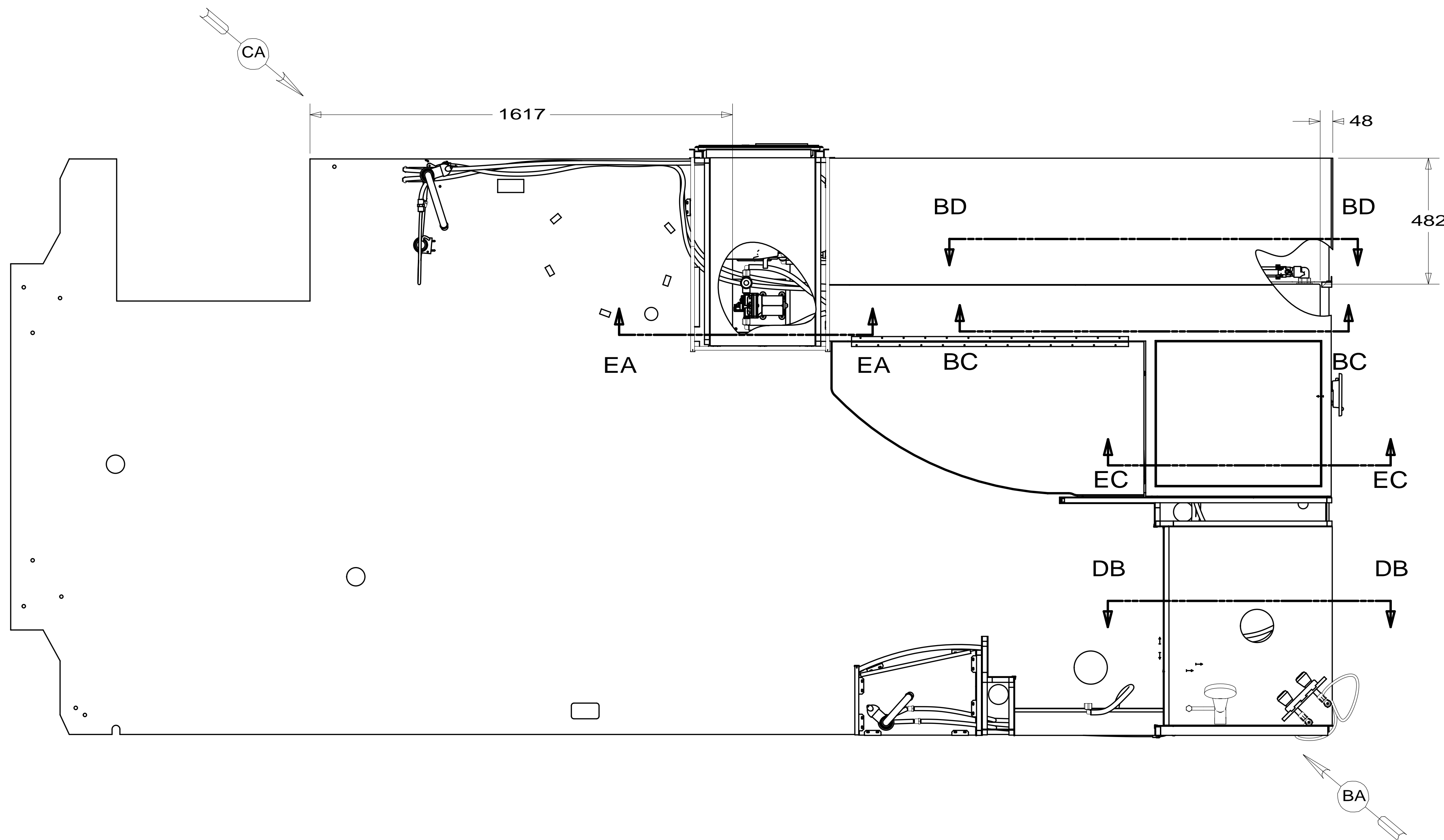

- 53E WATER SYS WINTERIZATION PKG
- 53B WTR HTR-6 GAL ELEC/LP/GAS
- 26B WATER PURIFIER
- 501 WATER PURIFIER WITHOUT
- 64R EXTERIOR WASH STATION

- 11 ENCASE FLEX WATER LINES IN CONVOLUTED TUBE (178782-00-300).
- 10 MOUNT TO COACH FLOOR PRIOR TO INSTALLING ON FLOOR OF CHASSIS.
- 9. INSTALL BYPASS PLUG FOR SYSTEM TESTING AND SHIPPING.
- 8. ALL CRIMP FITTINGS TO 1/2" PEX TUBING REQUIRE 1/2" CLAMP 140171-03-000.
- 7. ALL CRIMP FITTINGS TO 5/8" PEX TUBING REQUIRE 5/8" CLAMP 140171-04-000.
- 6 LABEL HOT AND COLD SUPPLY TUBES AND TAPE FITTING TO TUBE BEFORE CABINET SET TO PREVENT MOVEMENT.
- 5 ADD PIPE WRAP (LADDER SCRAP 110157-02-000) INSULATION.
- 4 ADD TEFLON TAPE 010405-02-000.
- 3. ALL TUBING TO BE SECURED AT 1200 INTERVALS MAXIMUM WITH CLAMP 010495-01-000 AND SCREW 000G67-10-12U OR EQUIVALENT.
- 2. TUBING TO BE INSTALLED WITH SUFFICIENT SLOPE TO PROVIDE DRAINAGE TO NEAREST VALVE.
- 1. PLASTIC FITTINGS TO BE SEALED WITH SEALANT 084456-01-000.

FOR WATER CALLOUTS SEE DWG NO 116230-01-000

		COPYRIGHT 2014 WINNEBAGO INDUSTRIES, INC.	
DFT-ORIG	ORIG. DATE	ALL DIMENSIONS ARE IN MILLIMETERS	
CHKR			
P.E.			
M.E.	FIRST USED		
DSNR		13 524J	
UNSPECIFIED TOLERANCES ARE:		MATERIAL:	
WHOLE DIM (X)	: 3		
ONE-PLACE (X.X)	: 1.5		
TWO-PLACE (X.XX)	: 0.50		
ANGLE	: 1°		
THIRD ANGLE PROJECTION			
DO NOT SCALE DRAWING		REFER TO ES0018 FOR FASTENER TIGHTENING GUIDELINES	
TITLE: WATER SYSTEM INSTL			
SHEET 1 OF 5	PART NO	181852	REV
REF:	1	17-Jan-2014	

NOTES:

* 181852 * A

FAUCET-LAV,SGL CNTL
171481-01-CHT
WASHER
E13-13-00B (2)

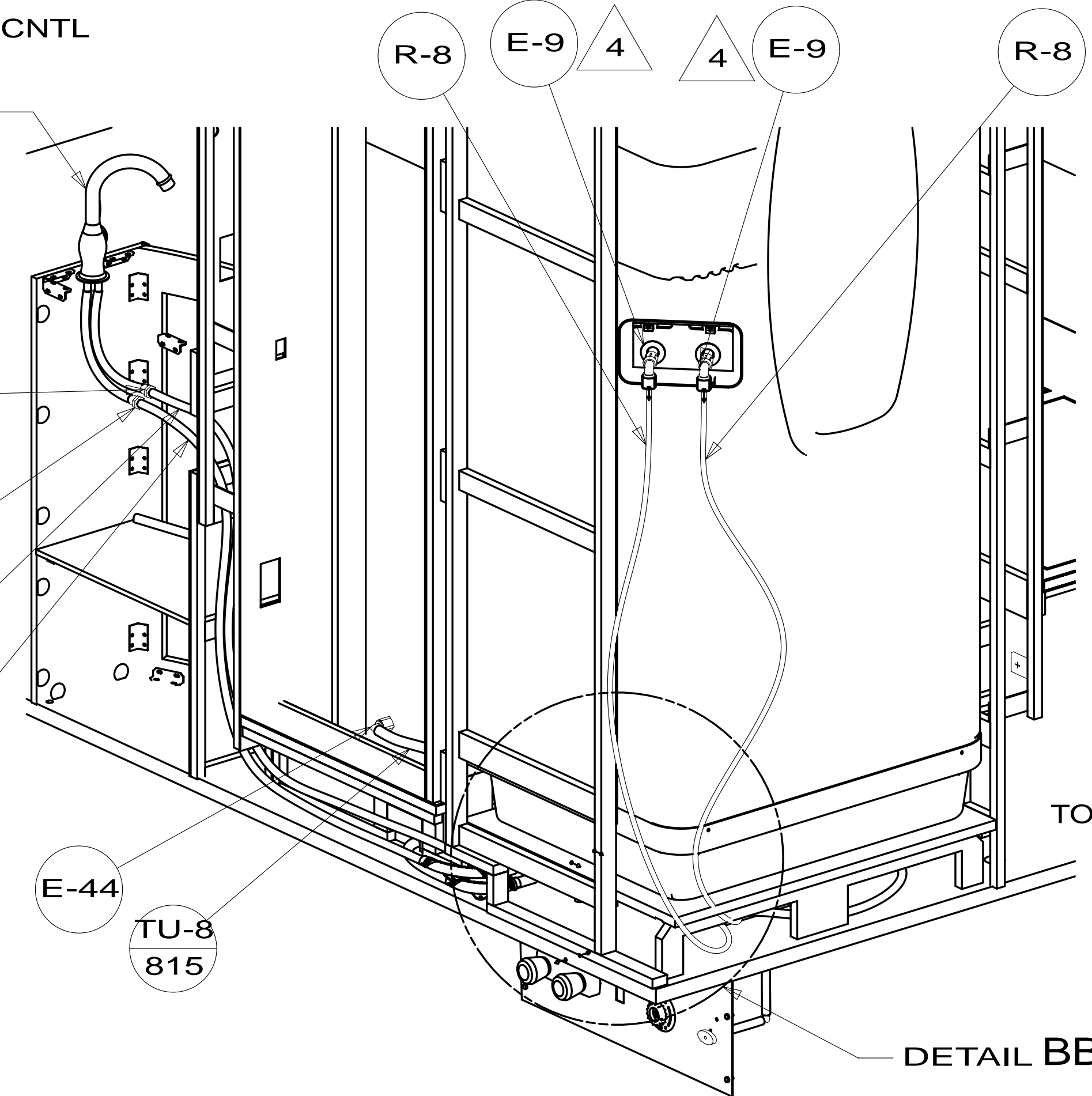

VIEW BA

CLAMP
010495-04-000(3)
RIVET
113133-03-CHT(3)

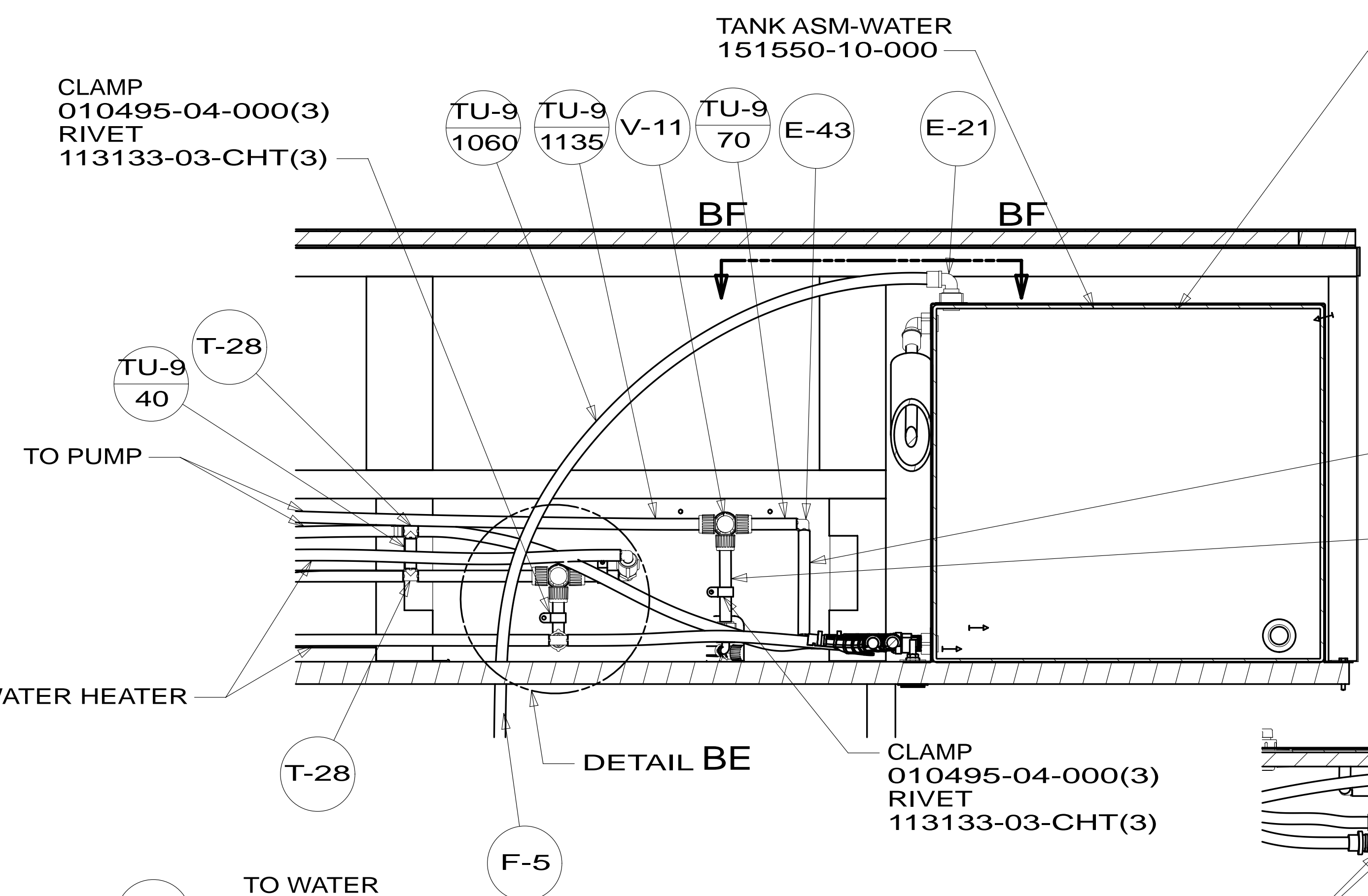

SECTION BC-BC

STRAP-TANK,WATER
118994-22-CHT (2)
SCREW
000G42-04-24U (2)
WASHER
000E13-16-00U (2)
PLATE ASM
174241-04-CHT
SCREW
000G39-10-08U(2)
NUT
000D39-05-00U(2)
WASHER
000E13-22-00U(2)

TU-9
145
TU-9
105

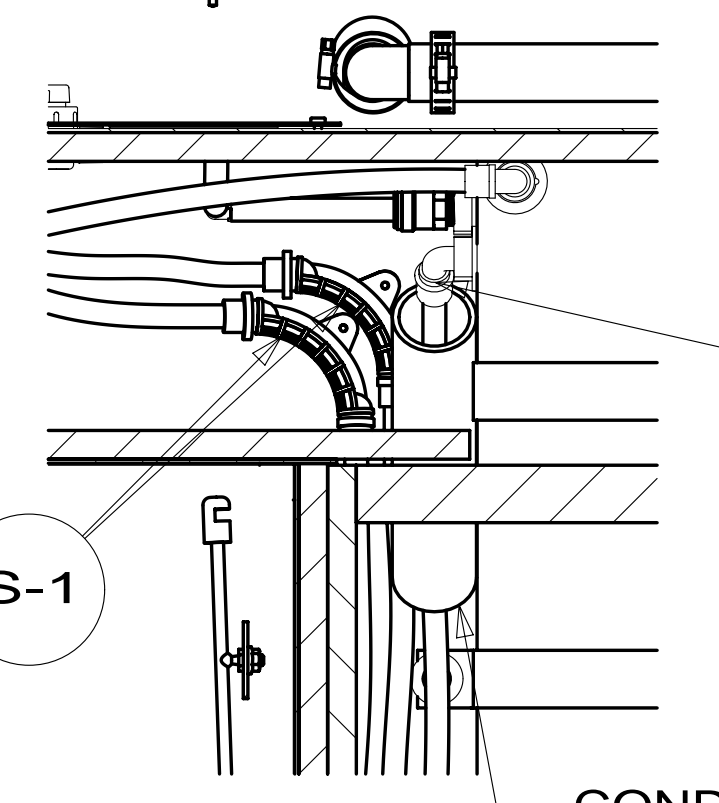

SECTION BF-BF

PANEL-WINTERIZATION VALVE
153917-01-CHT
SCREW-PAN HEAD
000G39-10-08U (5)

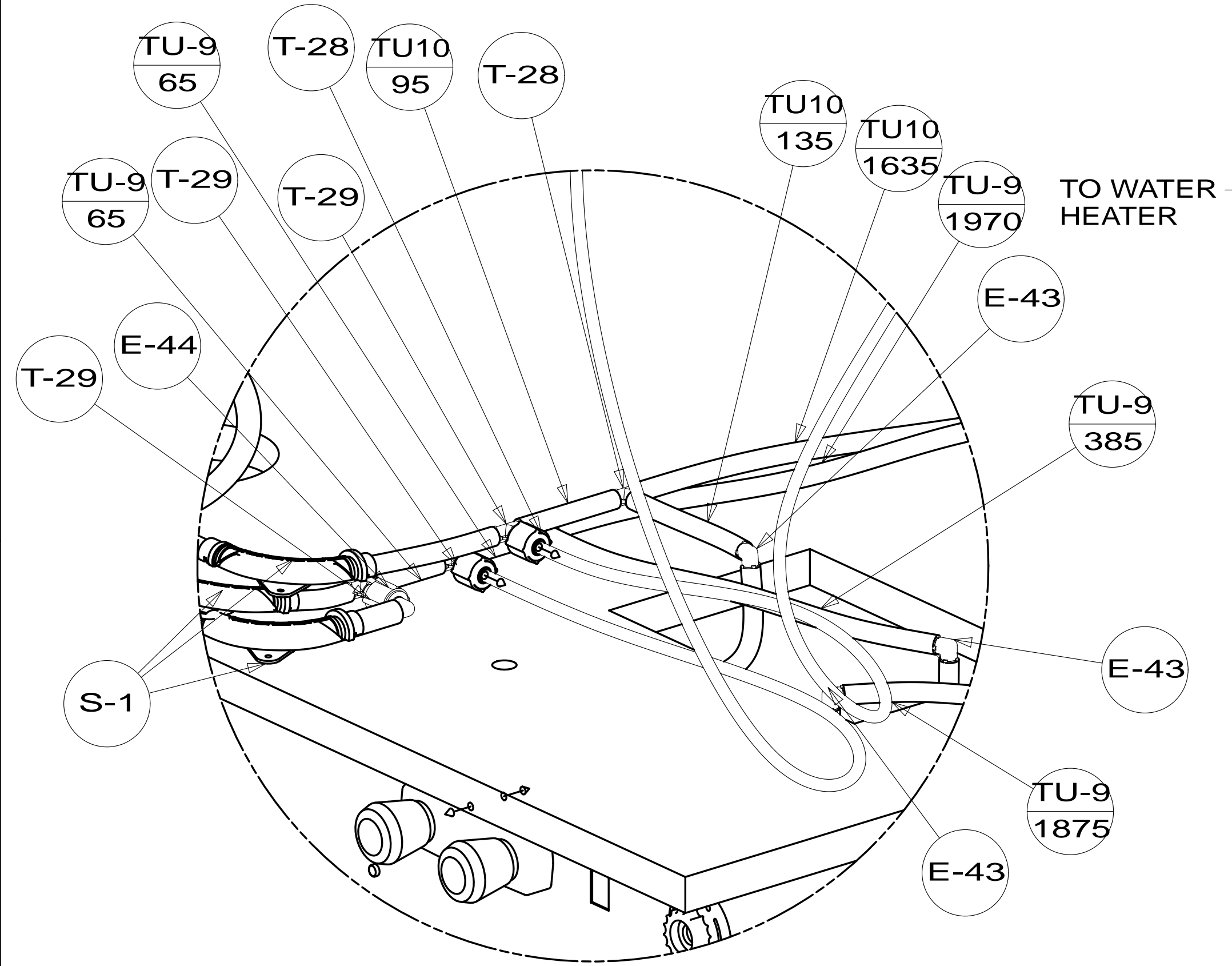

DETAIL BB
(SHOWN W/OUT CABINETS)

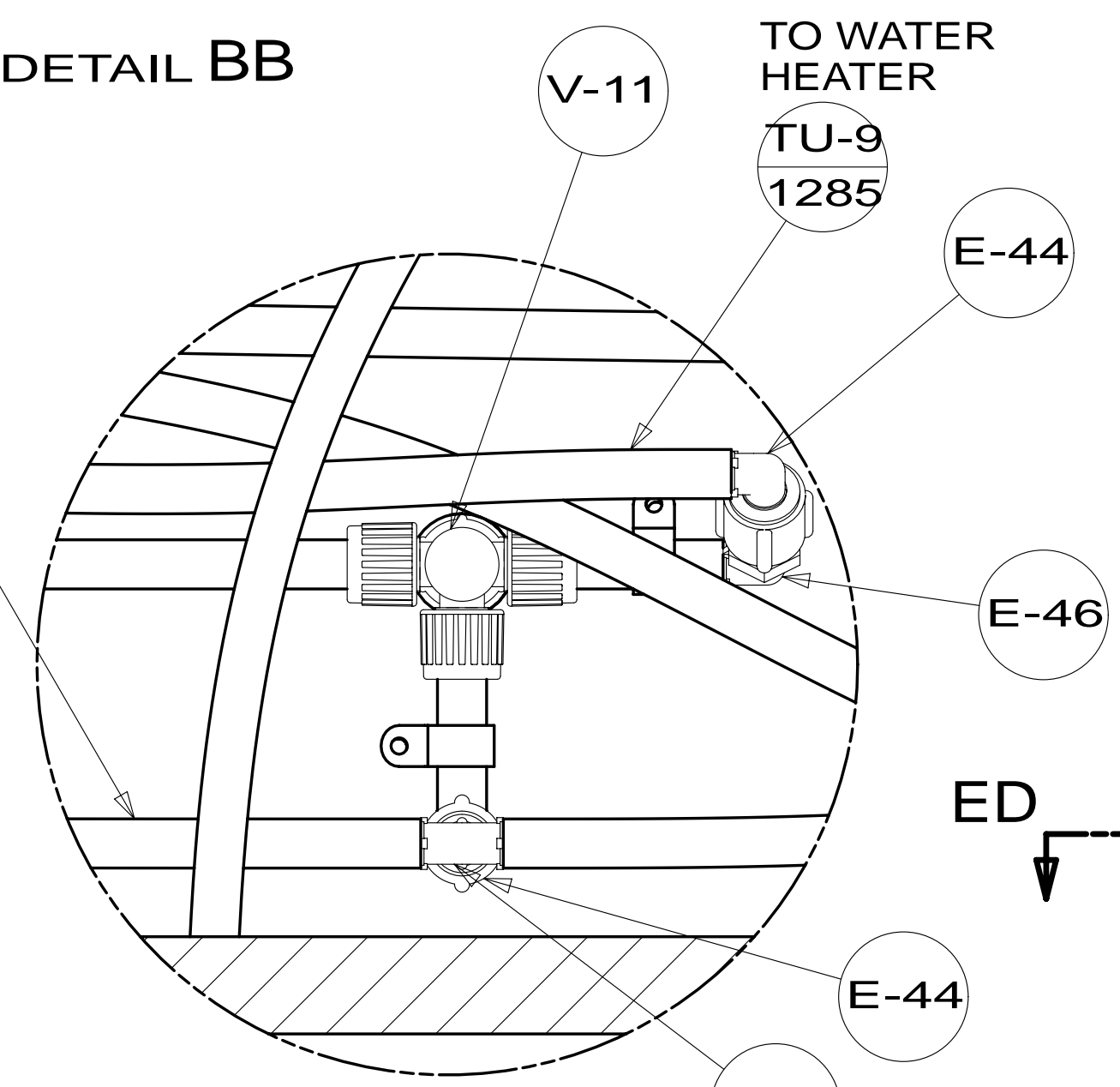

DETAIL BE

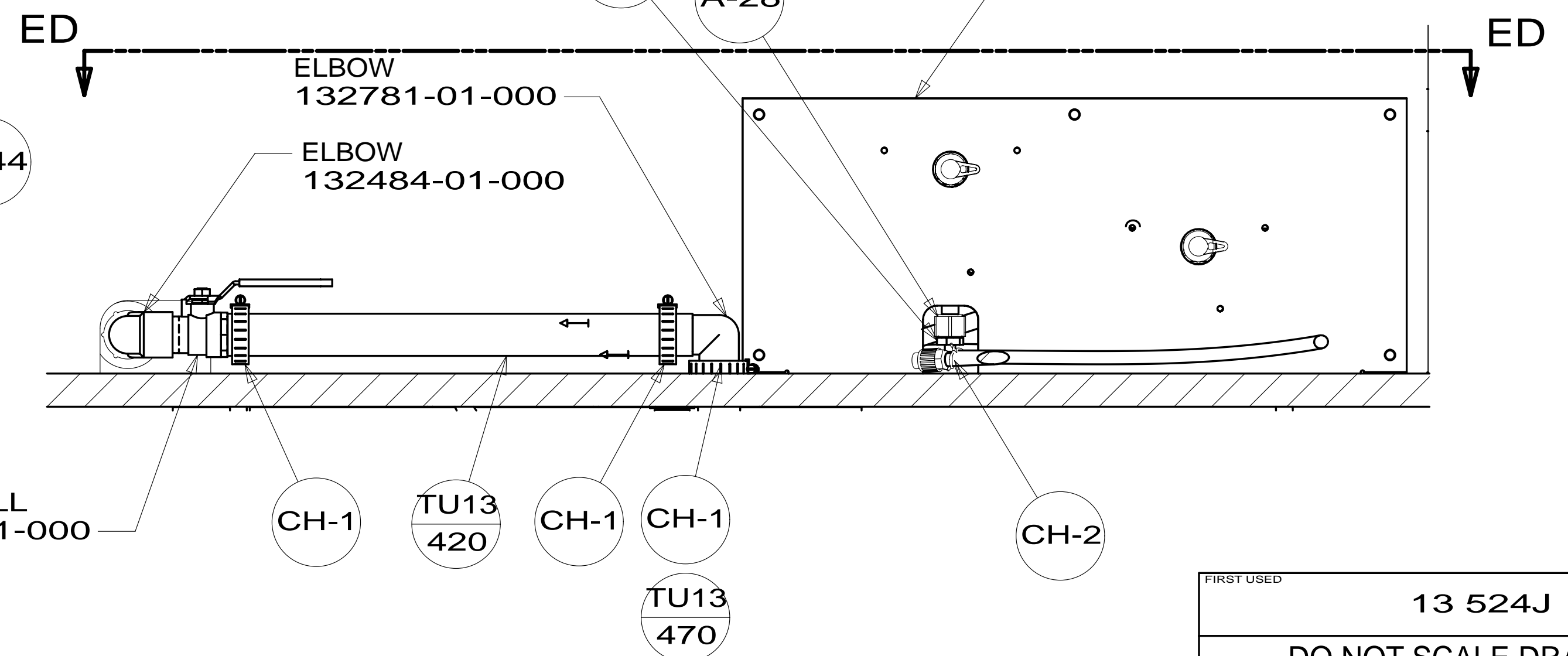

SECTION BD-BD
(ROTATED)

FIRST USED	13 524J
DO NOT SCALE DRAWING	
TITLE: WATER SYSTEM INSTL	
SHEET 2	PART NO 181852 REV
17-Jan-2014	

* 181852 * A

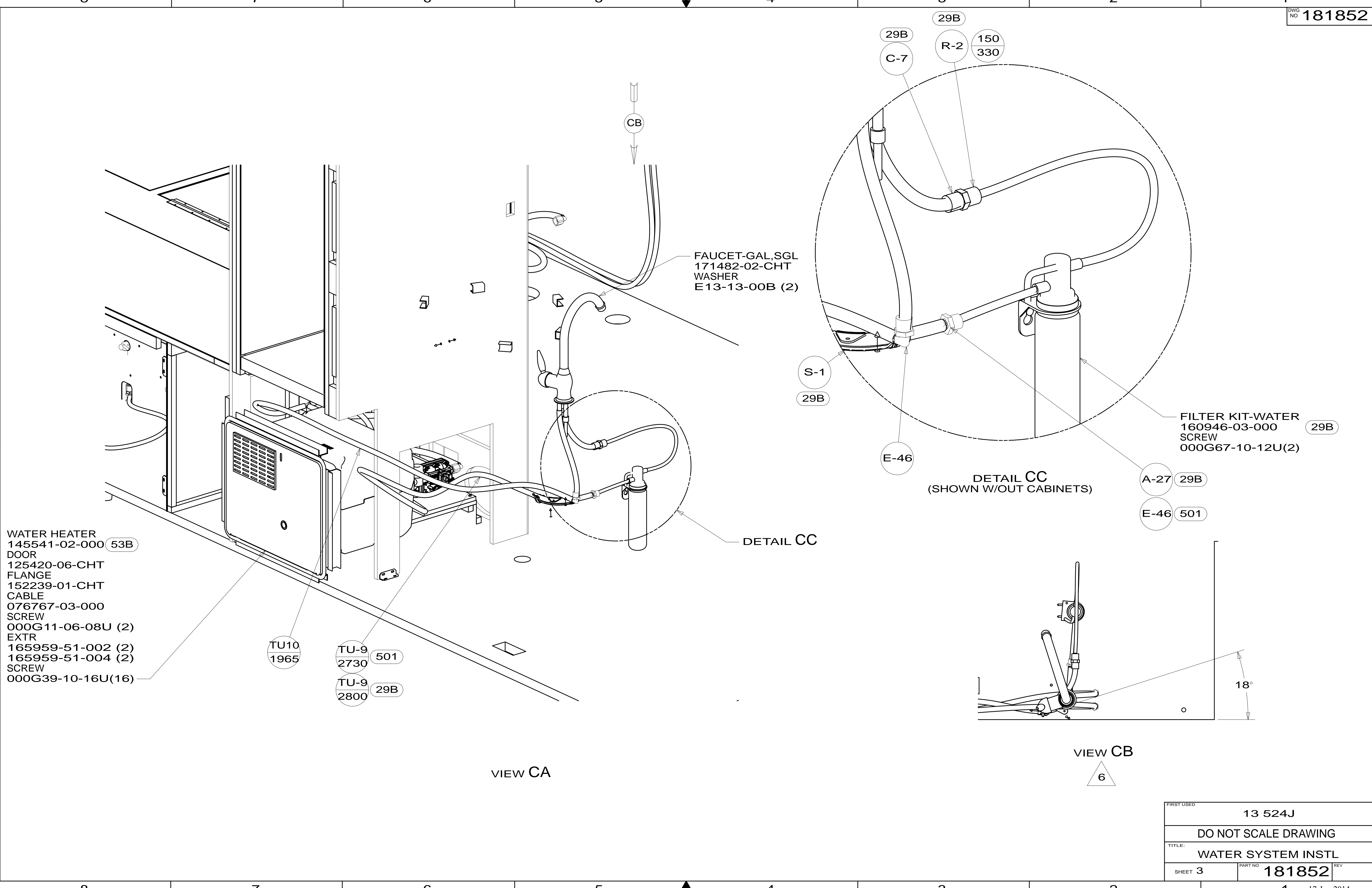

- WATER HEATER 145541-02-000 (53B)
- DOOR 125420-06-CHT
- FLANGE 152239-01-CHT
- CABLE 076767-03-000
- SCREW 000G11-06-08U (2)
- EXTR 165959-51-002 (2)
- 165959-51-004 (2)
- SCREW 000G39-10-16U(16)

FIRST USED	13 524J	
TITLE:	DO NOT SCALE DRAWING	
TITLE:	WATER SYSTEM INSTL	
SHEET 3	PART NO 181852	REV
		17-Jan-2014

* 181852 * A

SHOWER SURROUND REF 234 SHOWER-HAND HELD, WALL MOUNT 187372-01-CHT 114

F-2 PANEL-SHOWER FAUCET 167738-02-CHT NUT-SPEED 040921-05-000 (4)

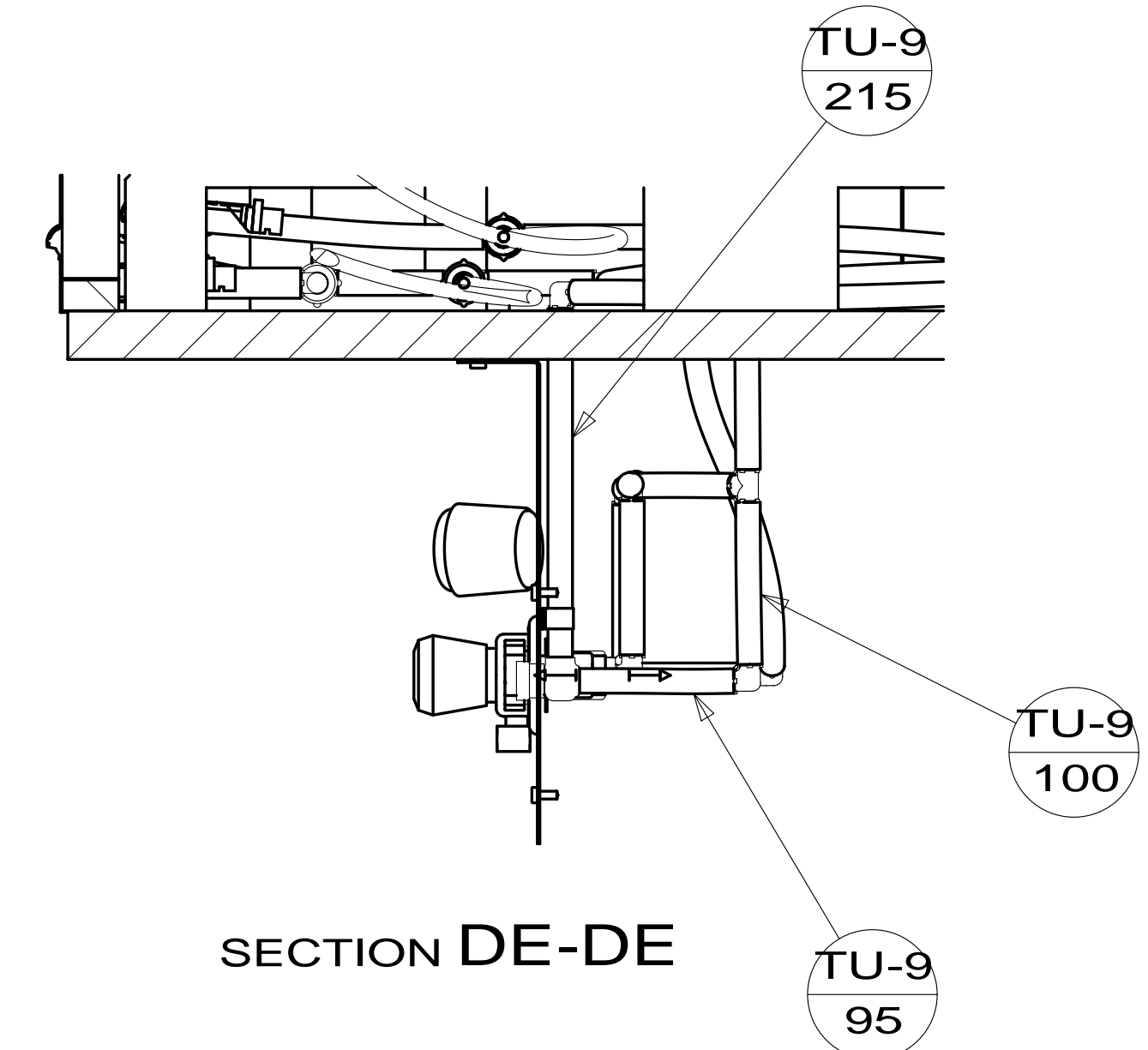

DA SECTION DB-DB

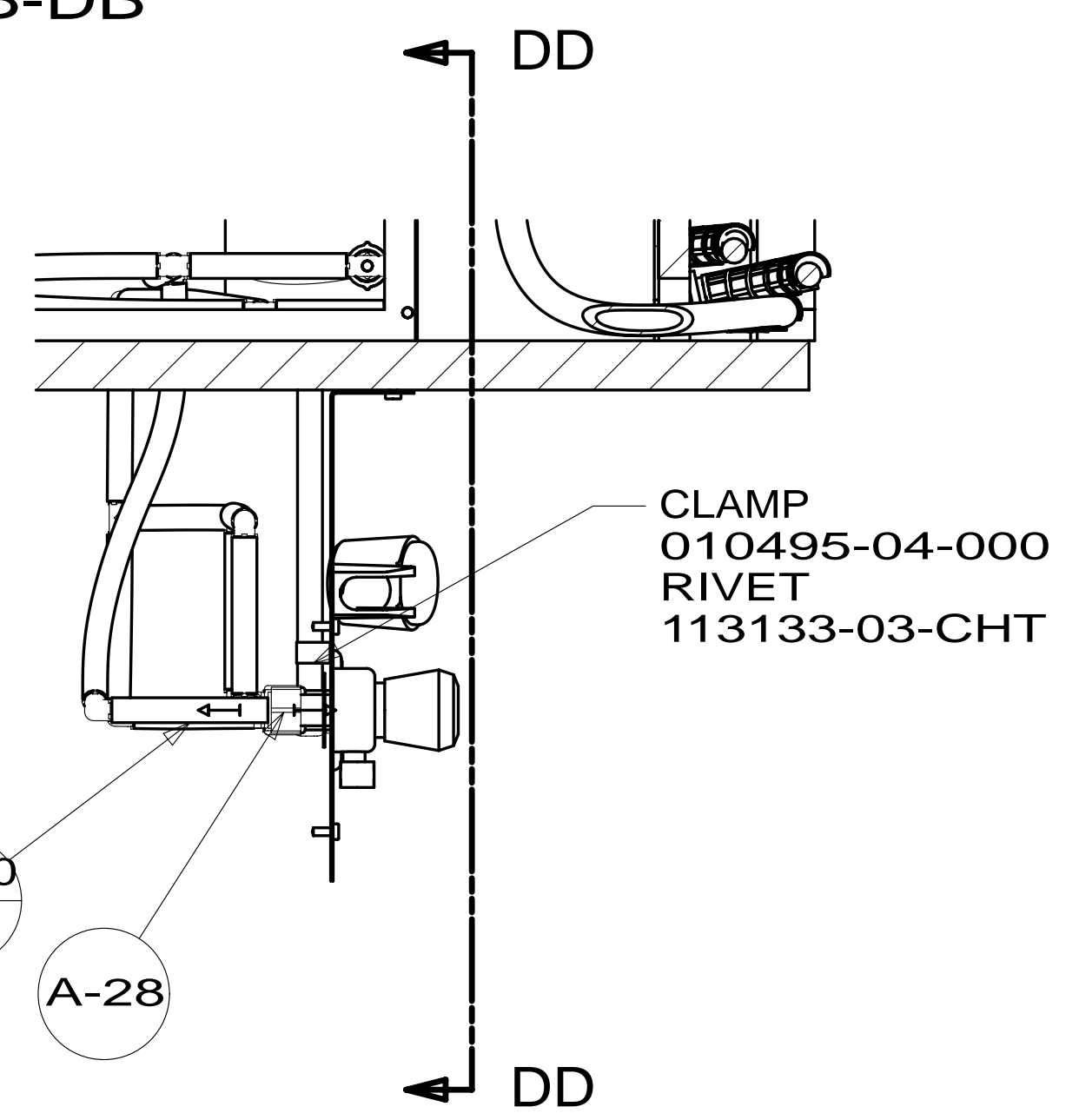

SECTION DC-DC

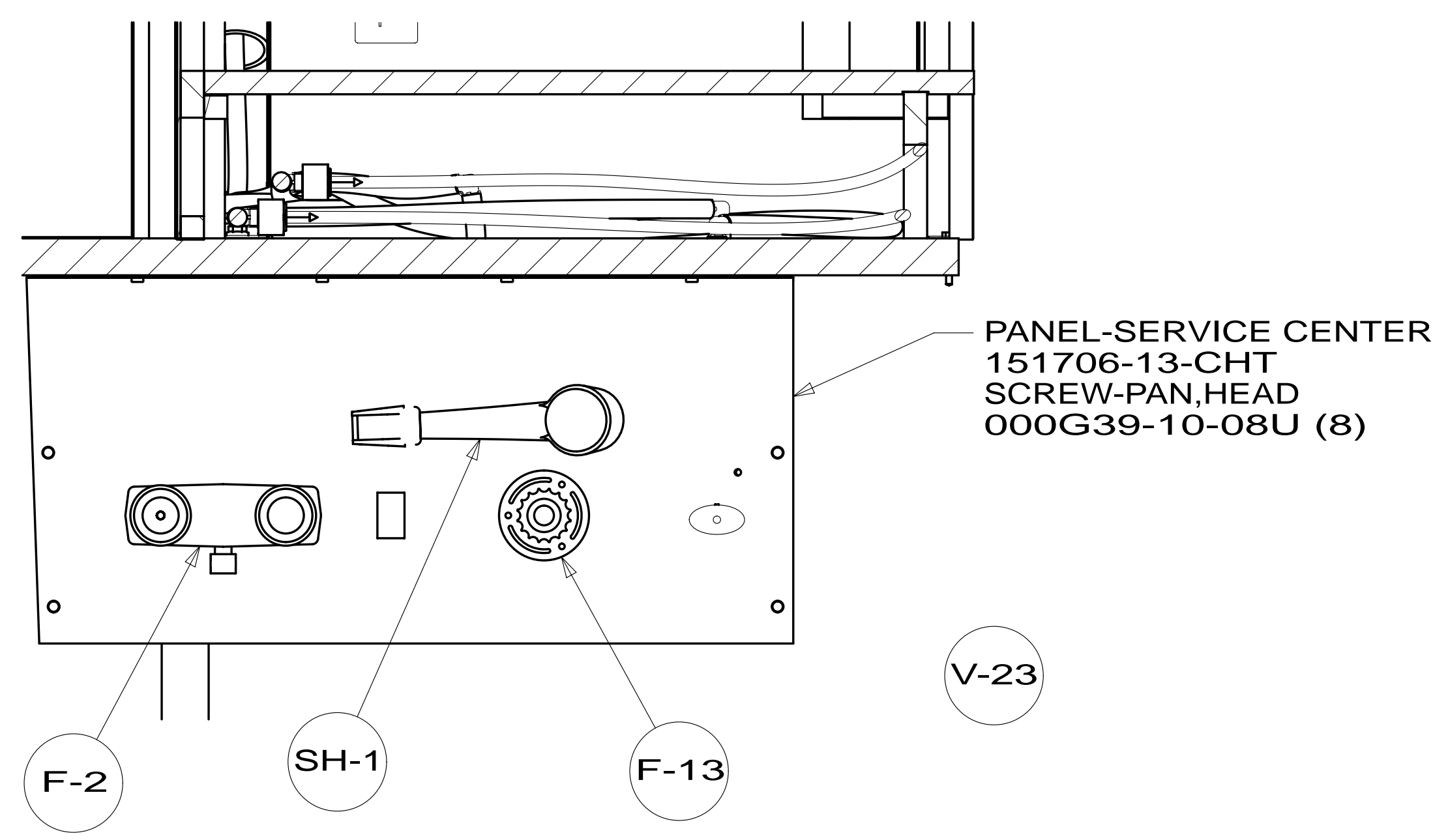

SECTION DD-DD

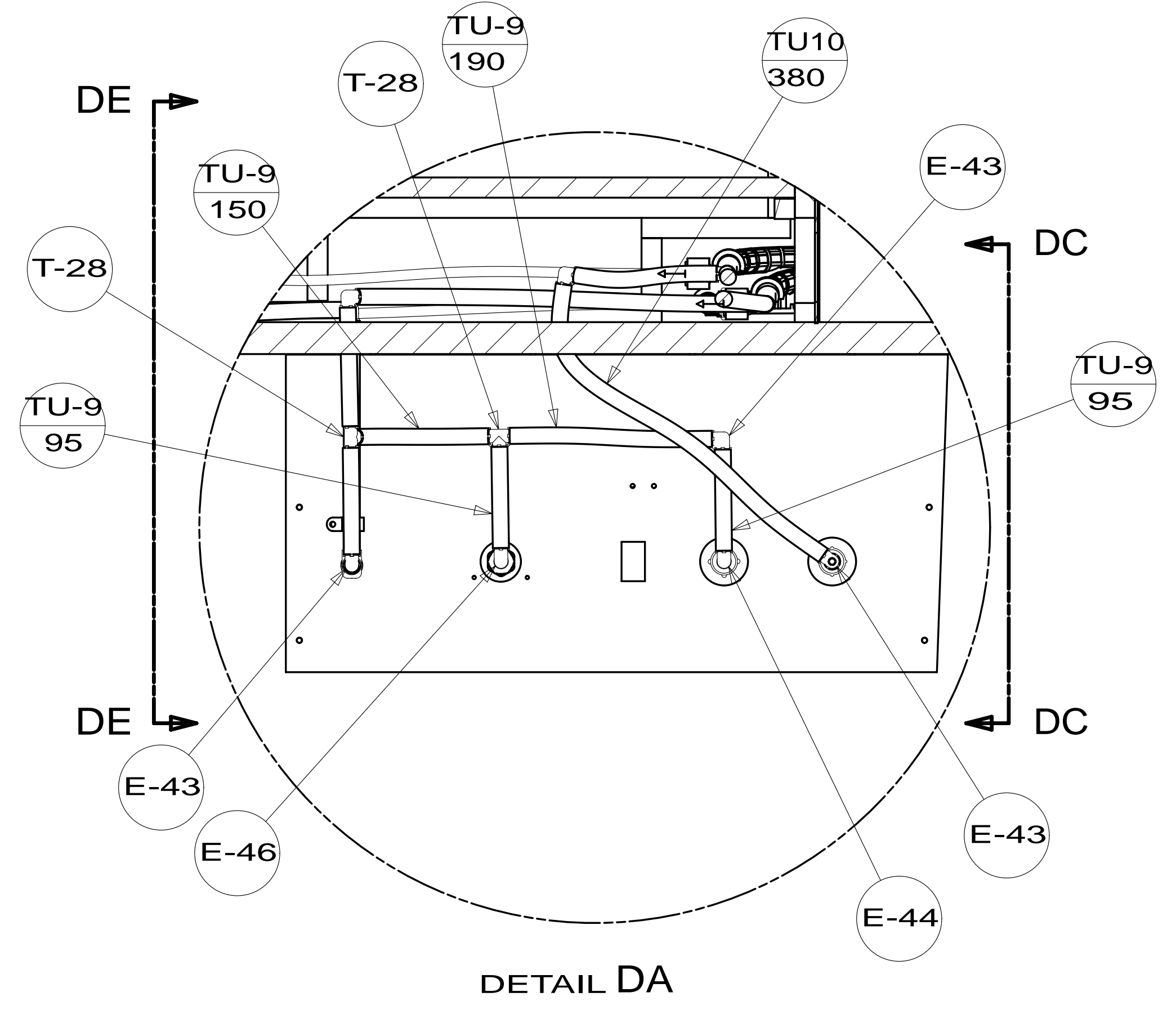

DETAIL DA

FIRST USED	13 524J	
TITLE:	DO NOT SCALE DRAWING	
	WATER SYSTEM INSTL	
SHEET 4	PART NO 181852	REV
		17-Jan-2014

* 181852 * A

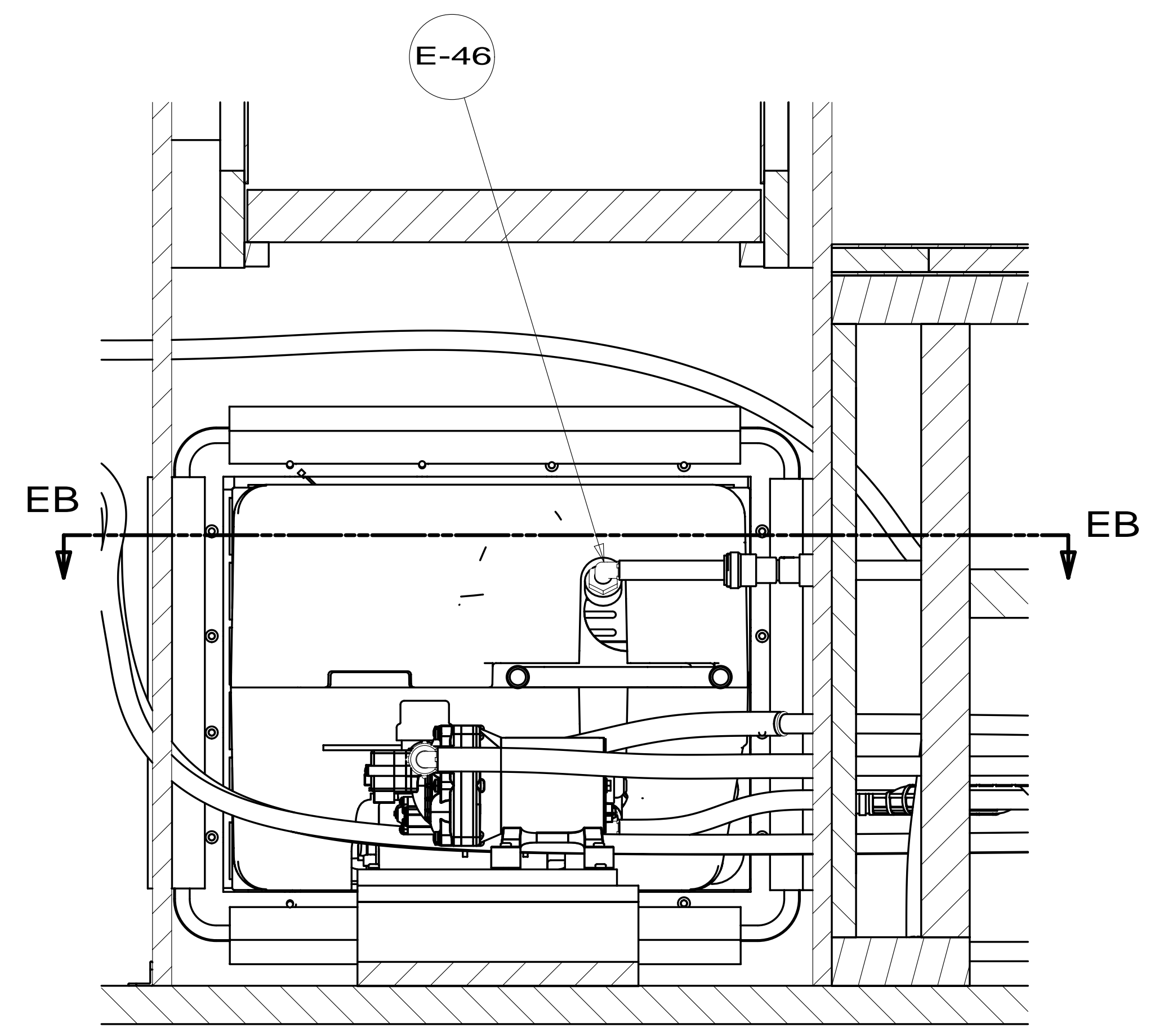

SECTION EA-EA

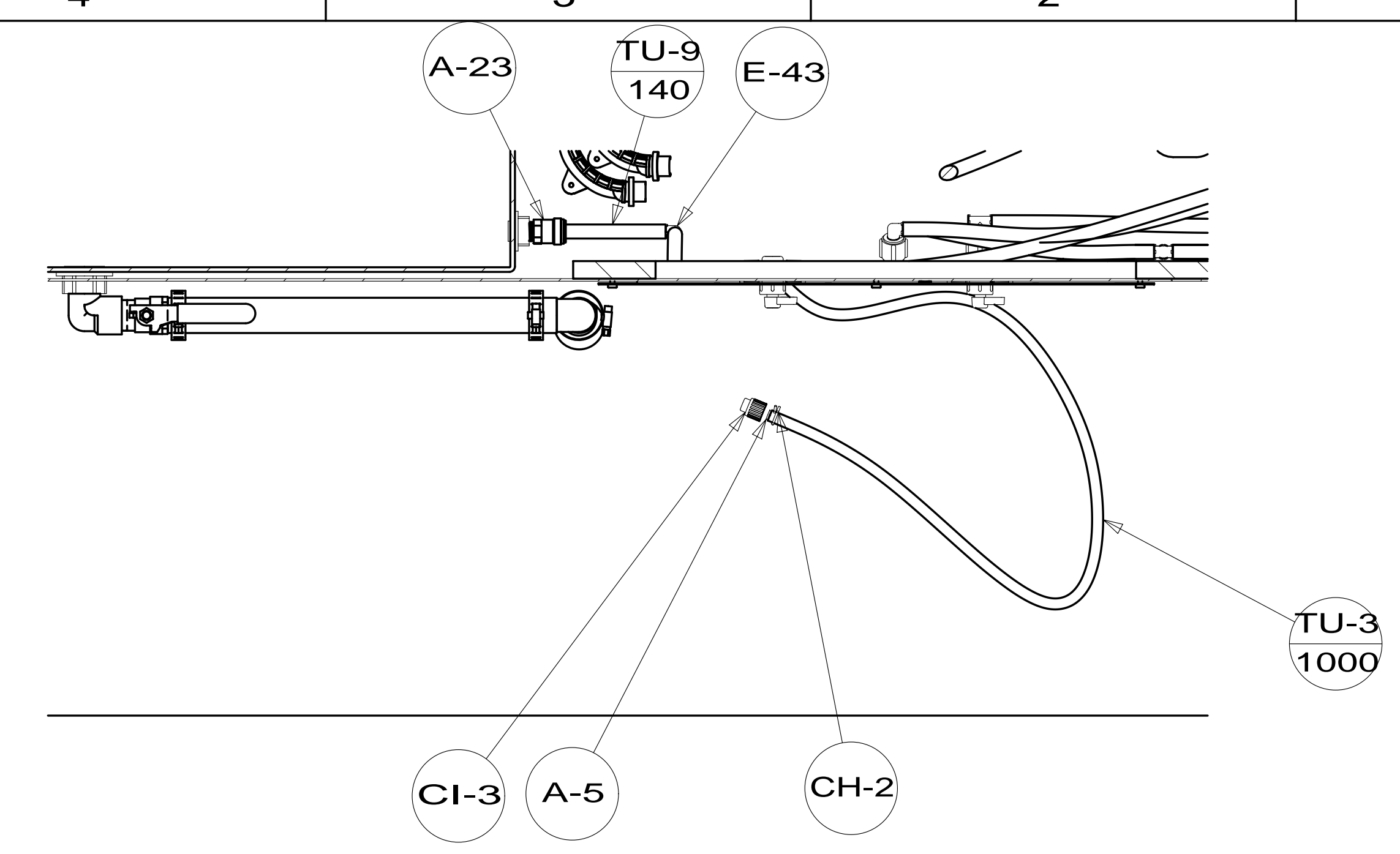

SECTION ED-ED

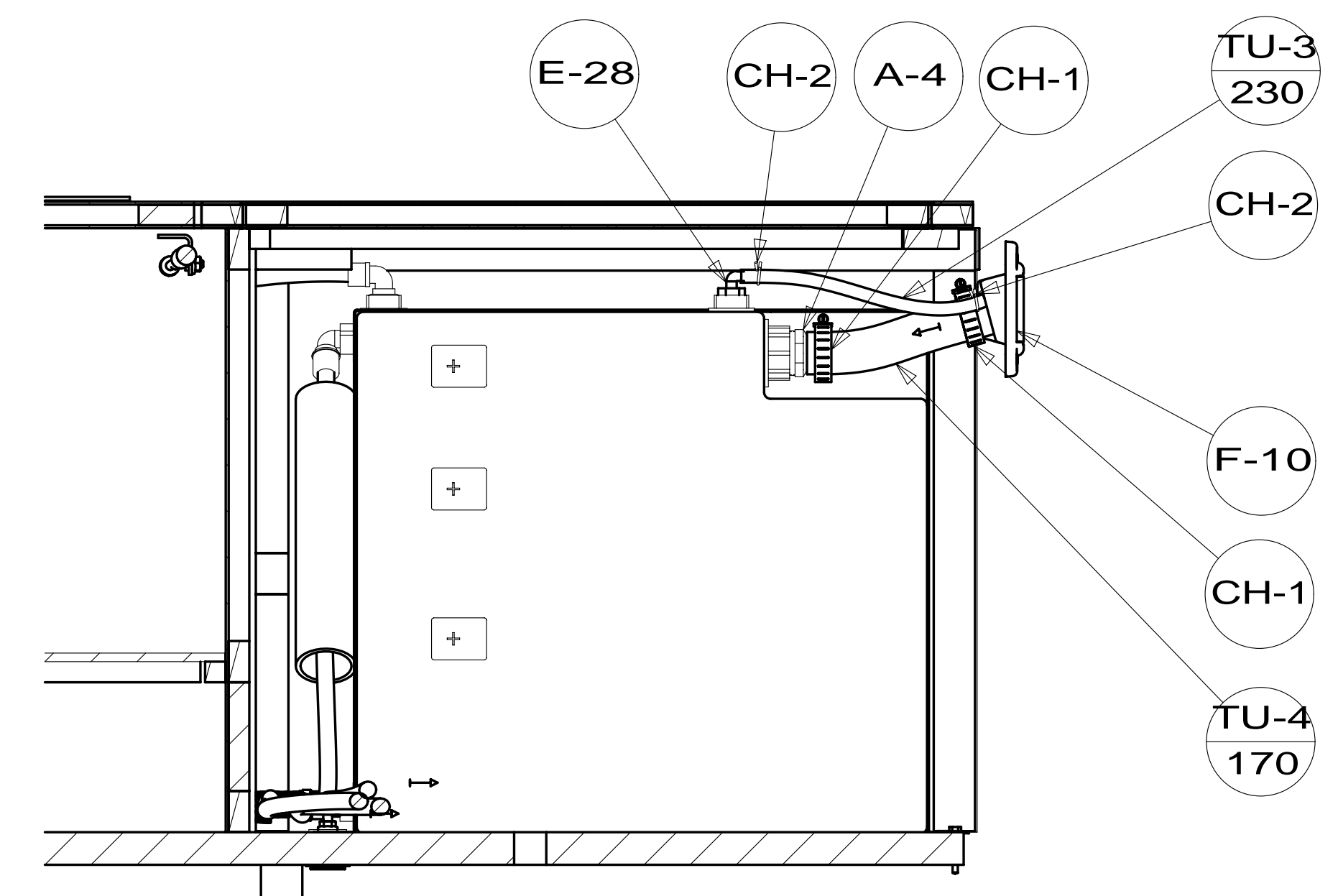

SECTION EC-EC

- PANEL-WATER PUMP
149477-08-CHT
- FOAM
140364-01-CHT
- SCREW
000G39-08-16U (4)
- PLATFORM
144200-03-000

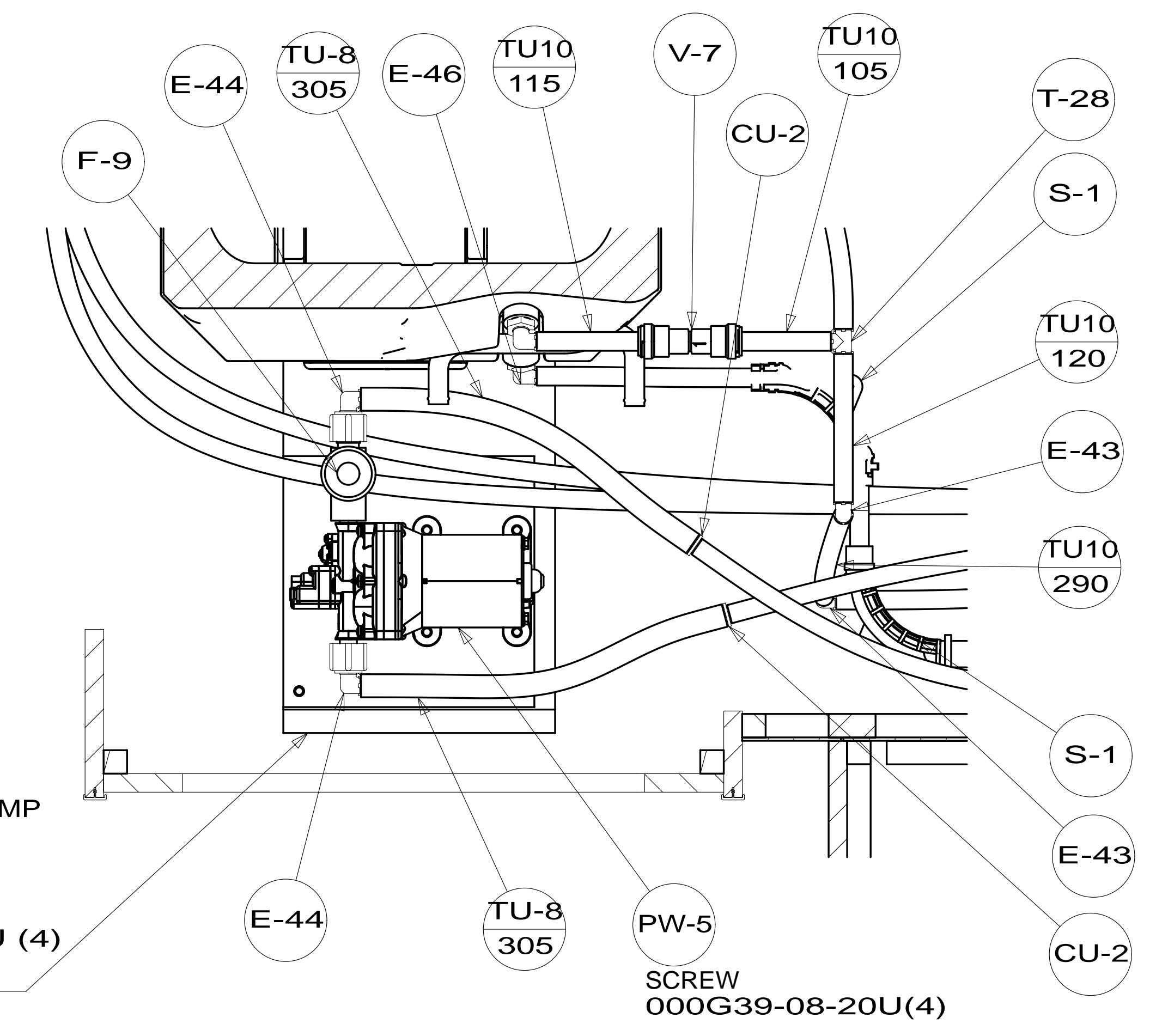

SECTION EB-EB

FIRST USED	13 524J	
TITLE:	DO NOT SCALE DRAWING	
TITLE:	WATER SYSTEM INSTL	
SHEET 5	PART NO 181852	REV
		17-Jan-2014

* 181852 *