

DWG NO	DETAIL	DETAIL	DETAIL	MODEL
184744-01	CC	BE	DA	331H
184744-02	CD	BF	DB	331HP

RELEASE	REV DATE	DWG NO	184744
REV ZONE	REVISION RECORD	DATE	DTR-ORIG

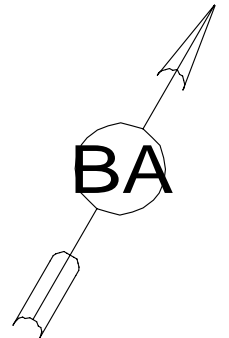
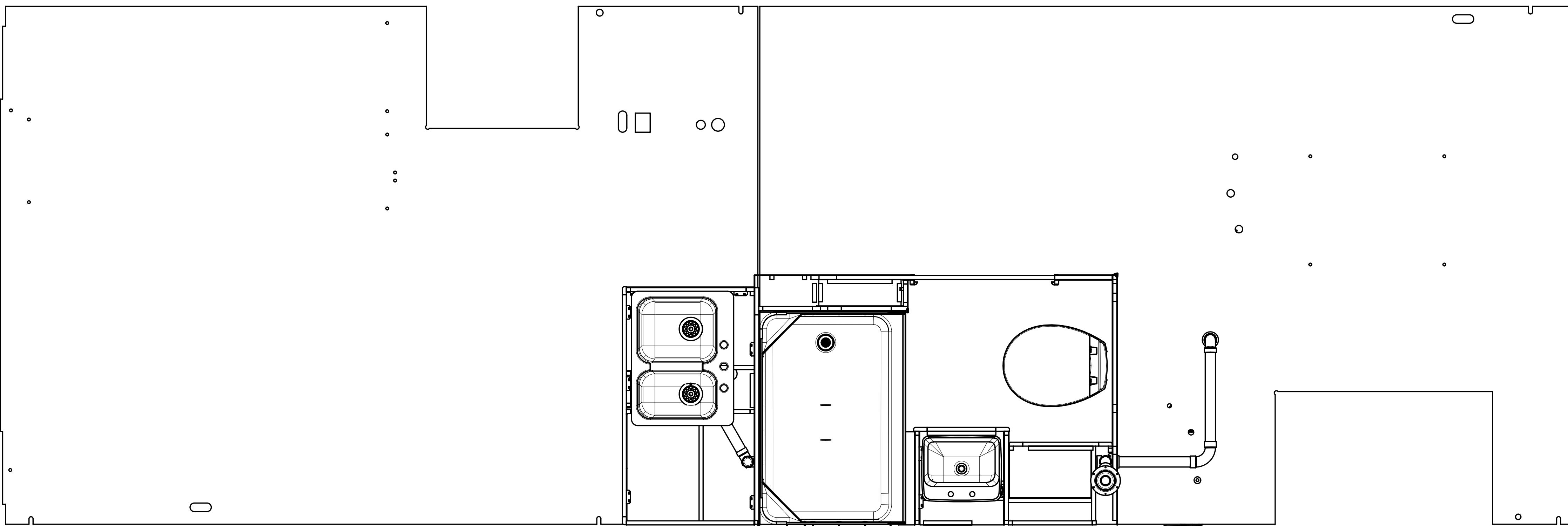

- 13. CUT DOWN 90MM
- 12. SEE WIRING INSTL-BODY FOR ELECTRICAL CONNECTION.
- 11. PREP THE SURFACE PER MANUFACTURERS INSTRUCTIONS BEFORE APPLYING THE HEATING PAD.
- 10. WATERLESS P-TRAP MUST BE INSTALLED WITH THE RIBS POINTING DOWN.
- 9. SEE DRAWING 061607 FOR INSTALLATION OF GROMMETS.
- 8. SECURE DRAINAGE PIPES TO CABINET USING WIRE TIE 108046-02-000, AND SCREW 000G67-10-12U AT INTERVALS OF NOT OF NOT MORE THAN 4 FEET APART.
- 7. SECURE VENT PIPE TO FLOOR WITH CLAMP 062401-02-000 (2), SCREW 000G67-10-12U (2), BRACKET 136878-01-CHT (2).
- 6. VENT PIPE MUST PROJECT 51 MIN AND 64 MAX ABOVE ROOF FOR PROPER FIT AND FUNCTION. ADD S-1 (116666-01-CHT SEAL-VENT PIPE) AROUND PIPE ON ROOF BEFORE VENT CAP IS INSTALLED.
- 5. SEAL AROUND SHOWER WITH SILICONE.
- 4. USE SMOOTH PLUMBERS PUTTY 167459-01-000 TO SEAL STRAINER (0.2 PER STRAINER).
- 3. ALL PIPE AND FITTINGS TO BE ASSEMBLED WITH SOLVENT 004020-01-000 (USA), 004020-02-000 (CAN)
- 2. SLOPE OF TRAP ARM MUST BE 6 PER 305 mm.
- 1. SLOPE OF HORIZONTAL PIPING TO BE MINIMUM OF 3 PER 305 mm.

- 464 TOILET
- 1B1 CODES/STANDARDS USA
- 265 CODES/STANDARDS-CSA/CMVSS
- 23T DRAINAGE SYSTEM-HEATED
- 644 GREAT ALASKAN RENTALS

FOR DRAINAGE CALLOUTS SEE DWG NO 116229-01-000

WINNEBAGO		COPYRIGHT 2014 WINNEBAGO INDUSTRIES, INC.	
DTR	ORIG. DATE	ALL DIMENSIONS ARE IN MILLIMETERS	
CHKR			
P.E.			
M.E.	FIRST USED	14 331H	
DSNR			
UNSPECIFIED TOLERANCES ARE:		MATERIAL:	
WHOLE DIM (X)	: 3		
ONE-PLACE (X.X)	: 1.5		
TWO-PLACE (X.XX)	: 0.50		
ANGLE	: 1°		
THIRD ANGLE PROJECTION			
DO NOT SCALE DRAWING		REFER TO ES0018 FOR FASTENER TIGHTENING GUIDELINES	
TITLE: DRAINAGE SYSTEM INSTL			
SHEET 1 OF 4	PART NO	184744	REV
REF:	1	21-Apr-2014	

NOTES:

* 184744 *

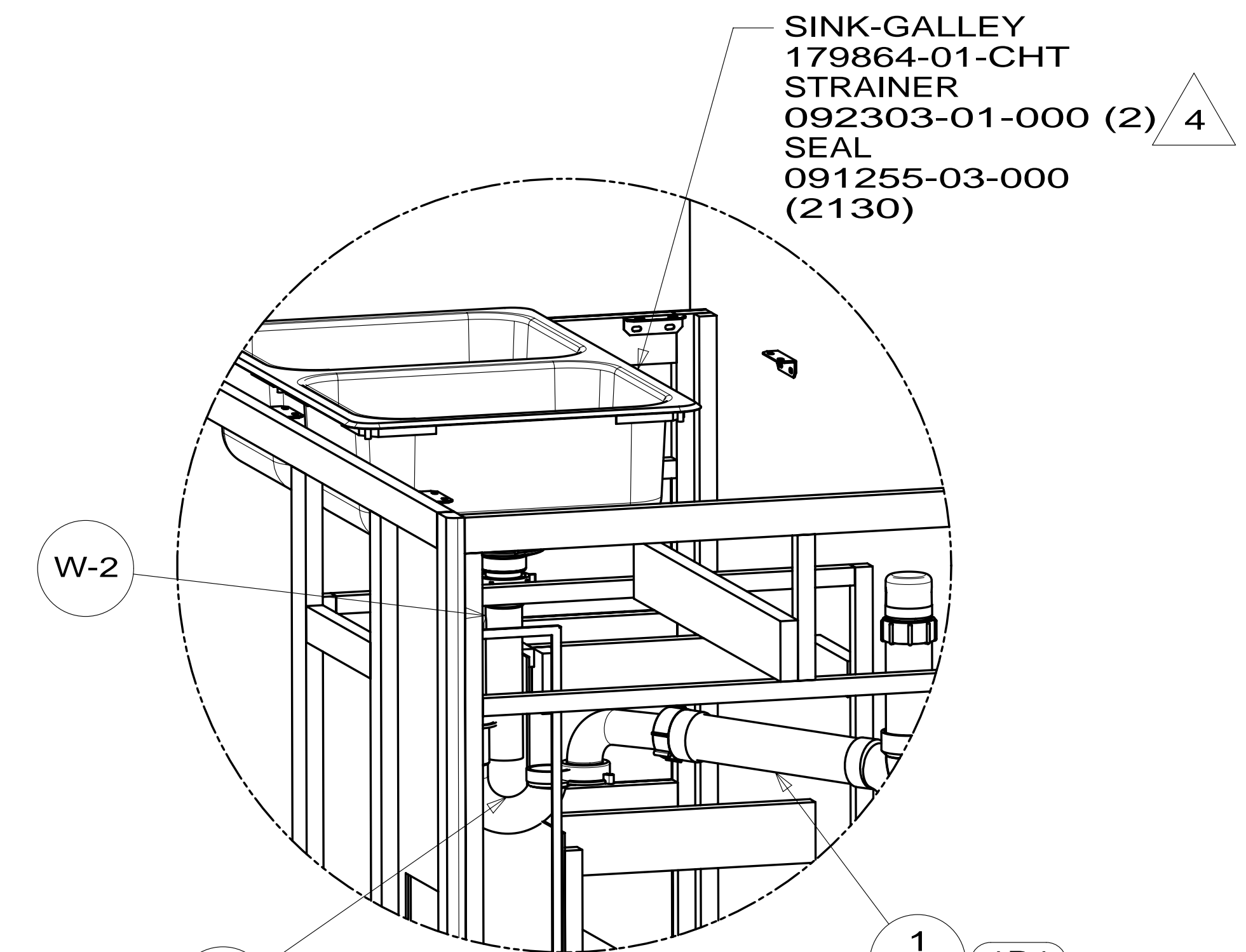
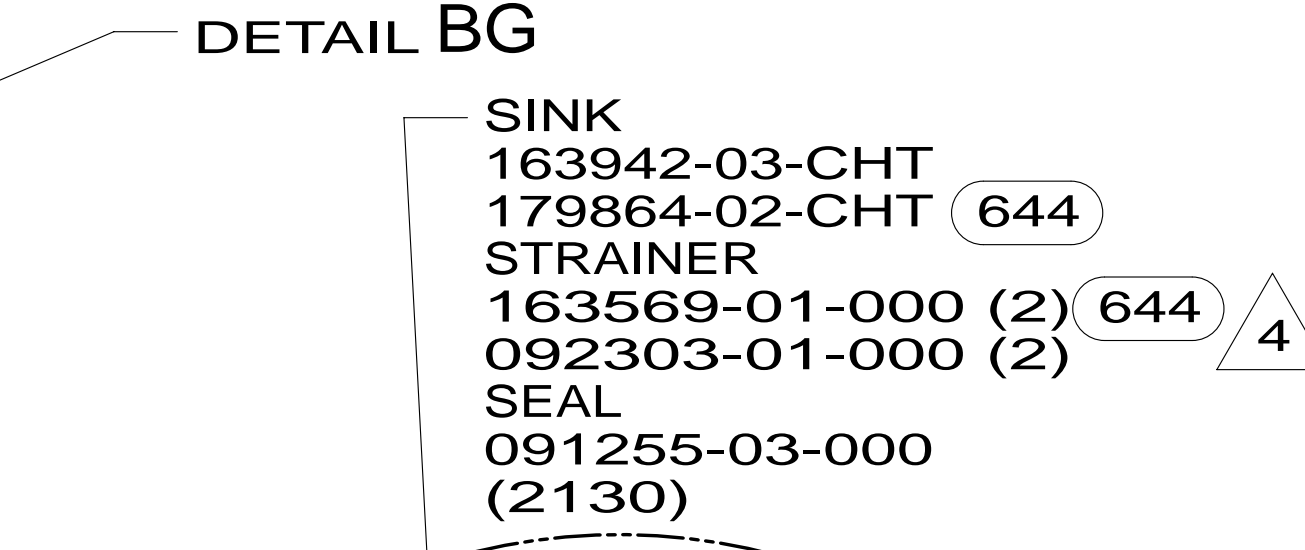
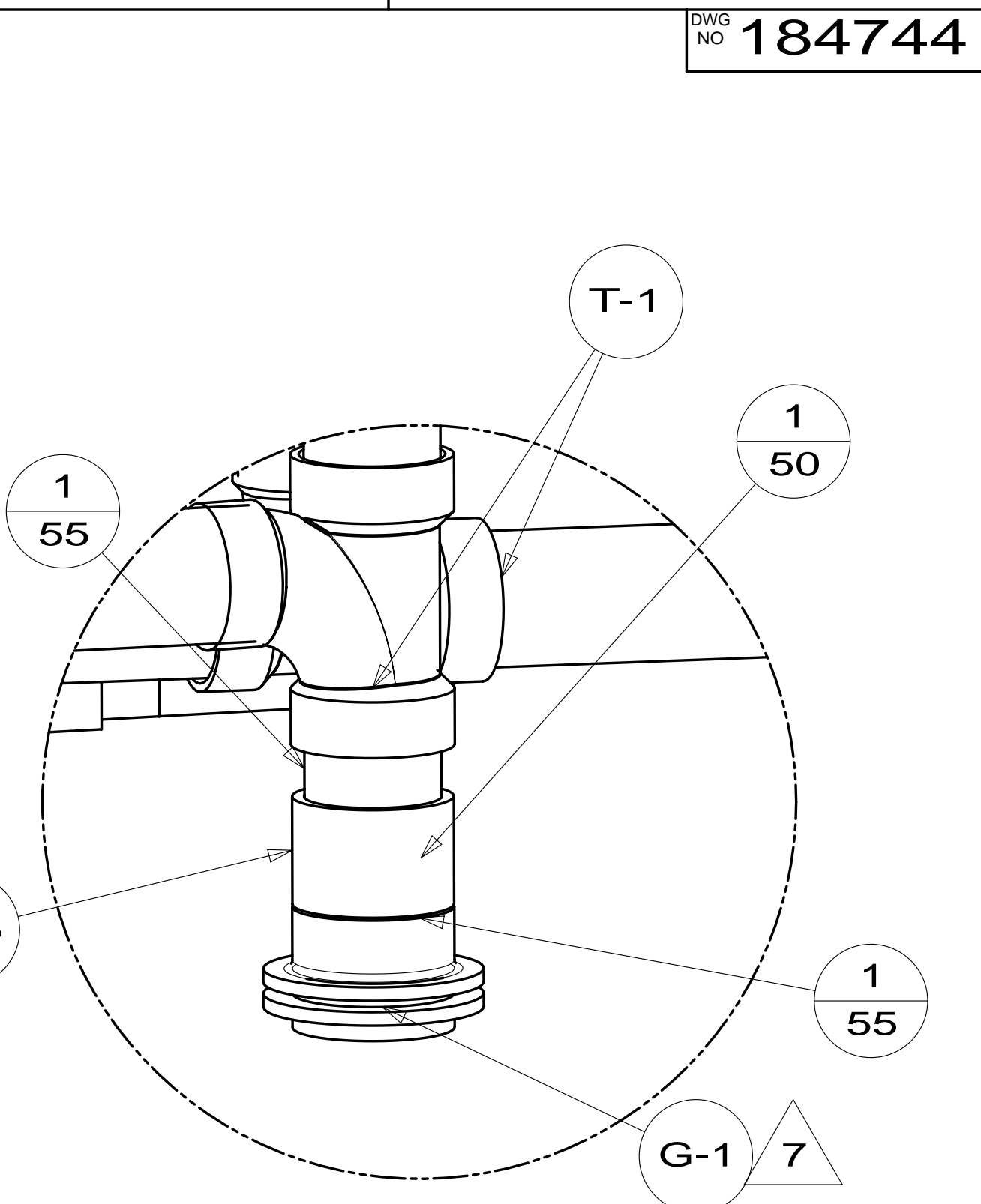
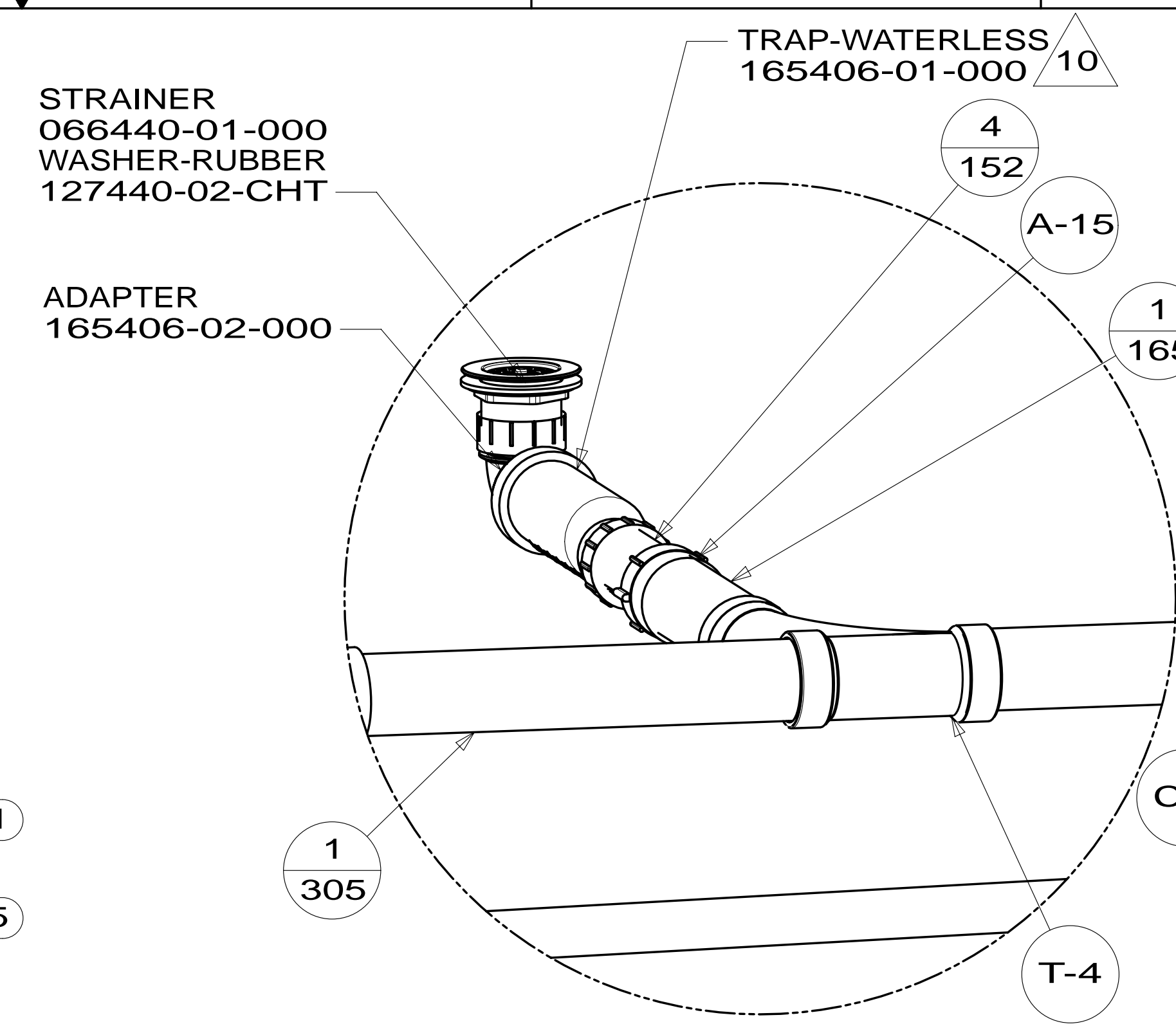
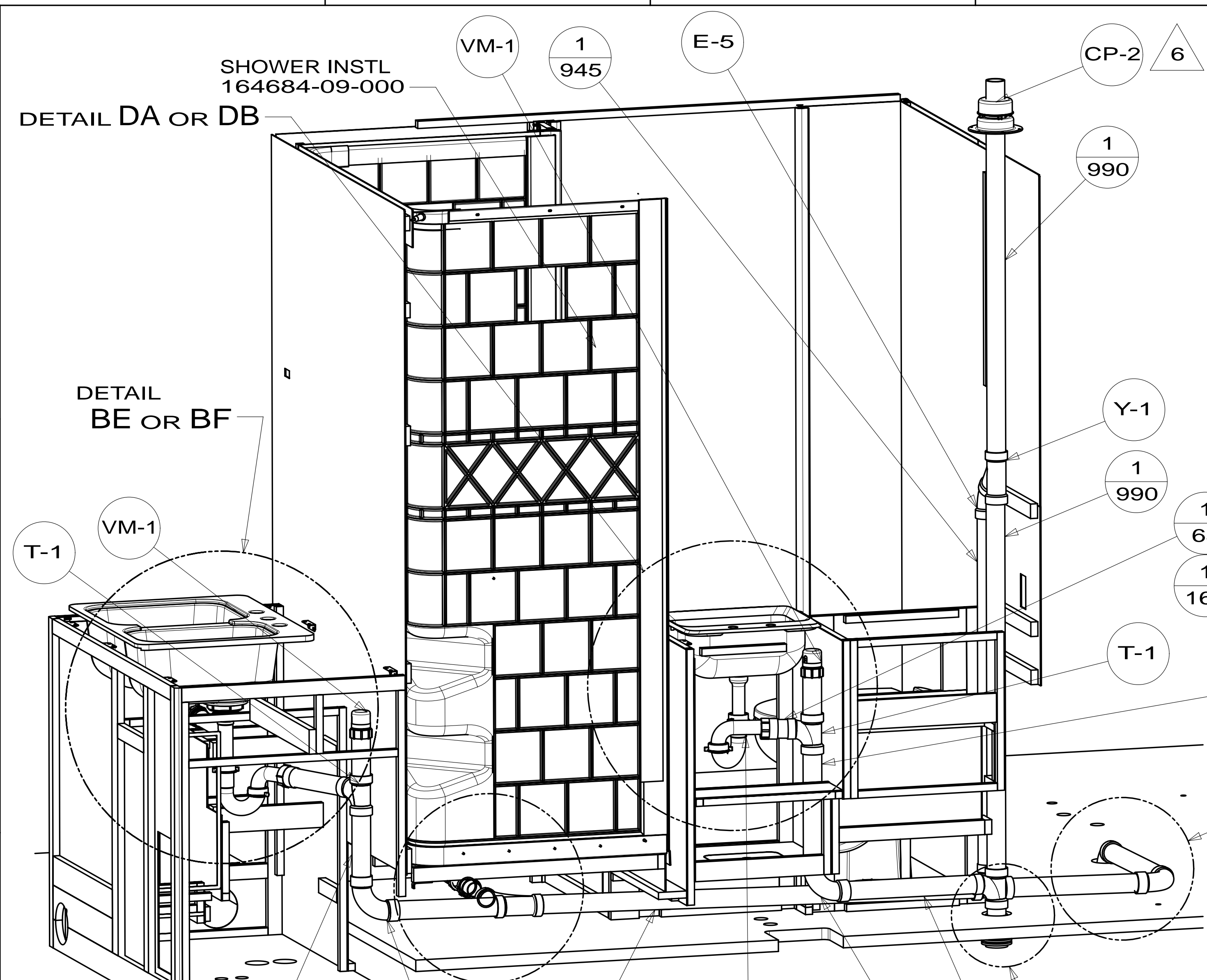

FIRST USED	14 331H
DO NOT SCALE DRAWING	
TITLE: DRAINAGE SYSTEM INSTL	
SHEET 2	PART NO 184744 REV
21-Apr-2014	

* 184744 *

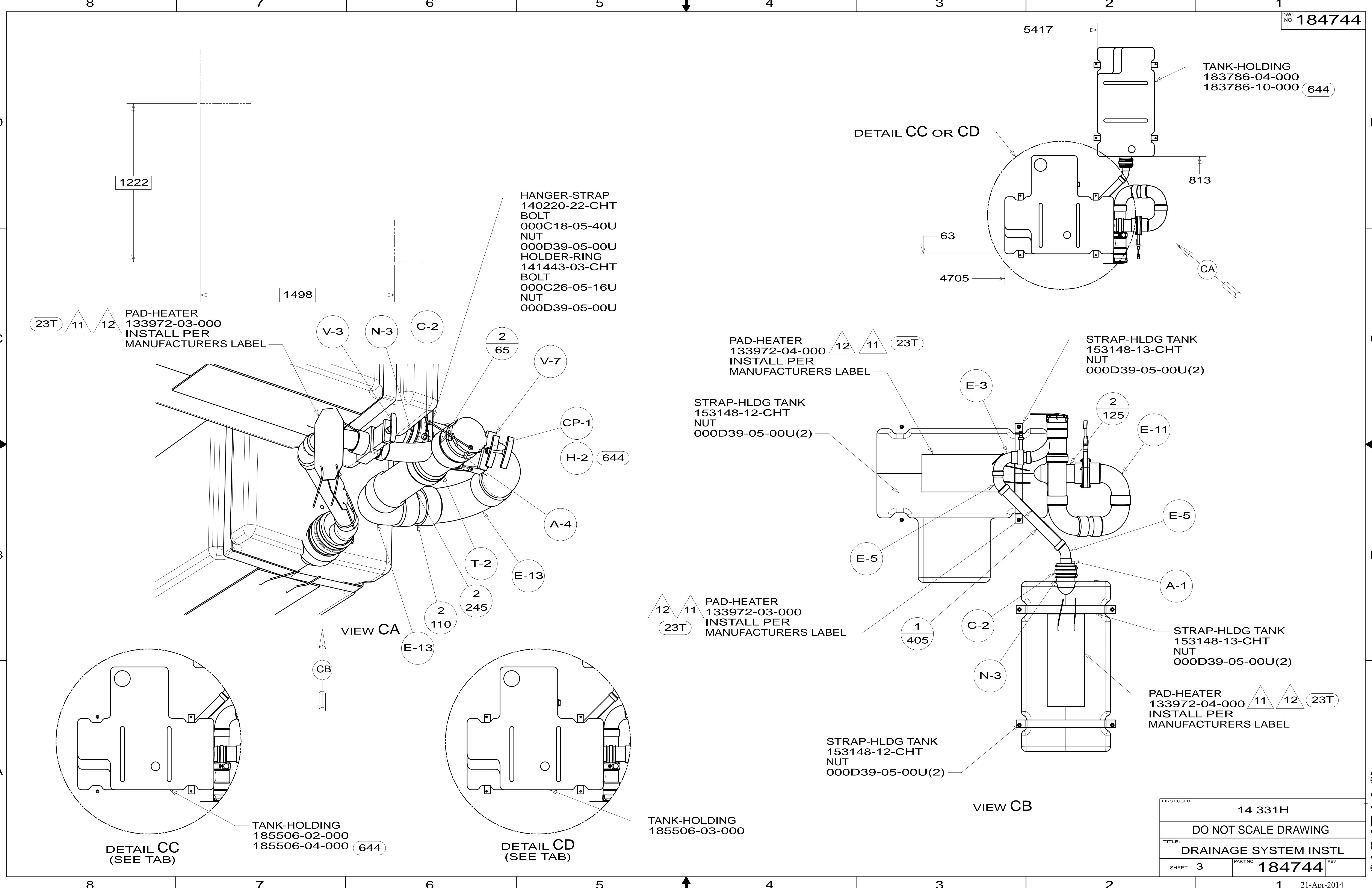

FIRST USED	14 331H	
TITLE:	DO NOT SCALE DRAWING	
SHEET	3	PART NO 184744 REV
		1 21-Apr-2014

* 184744 * A

SINK-LAVATORY,RECTANGLE
096927-01-CHT
SEAL
091255-02-000 (A/R)

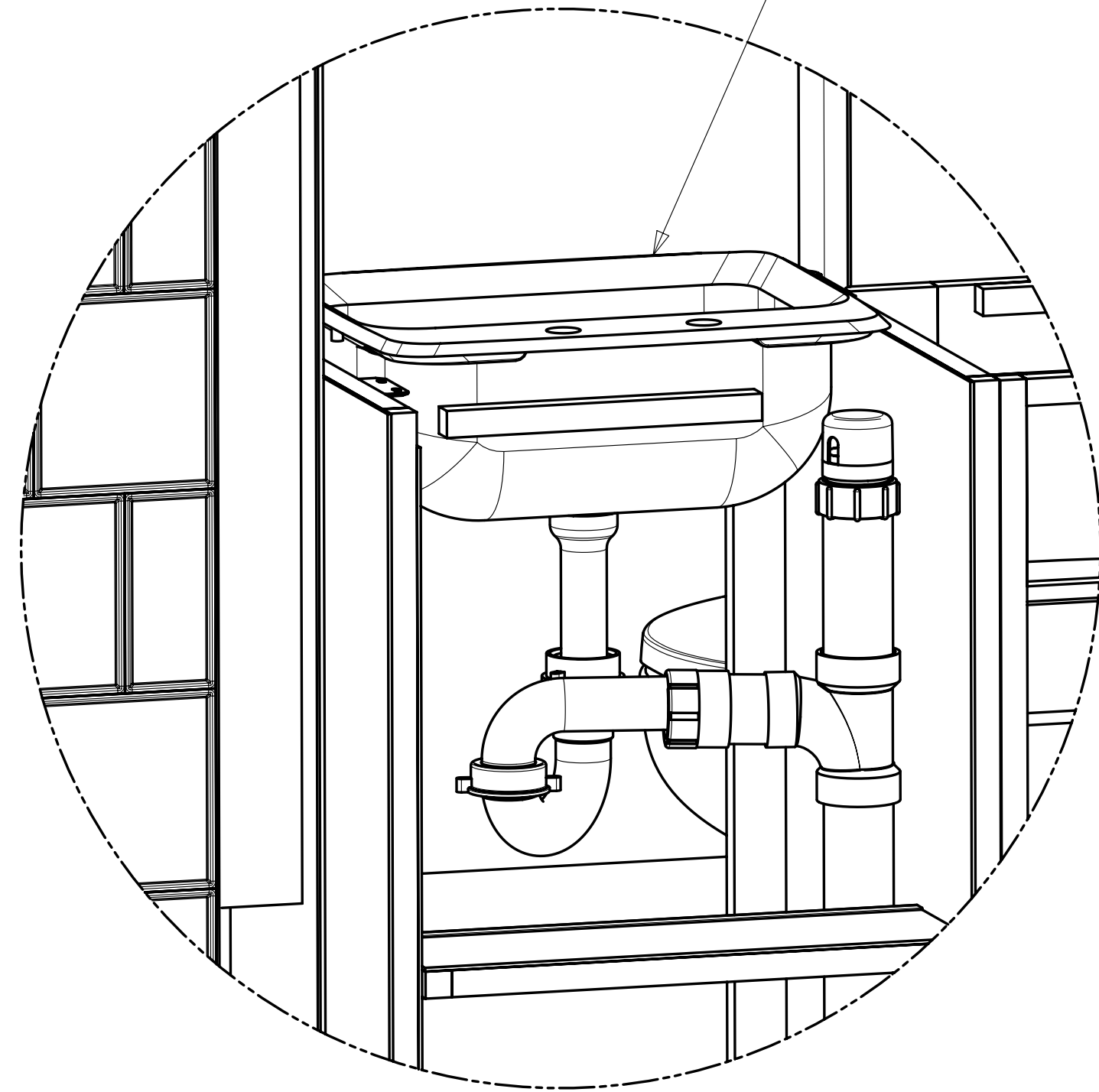

DETAIL DA
(SEE TAB)

SINK-LAVATORY,OVAL
184546-01-CHT
SEAL
091255-02-000 (A/R)
TAIL PIECE
106116-01-CHT

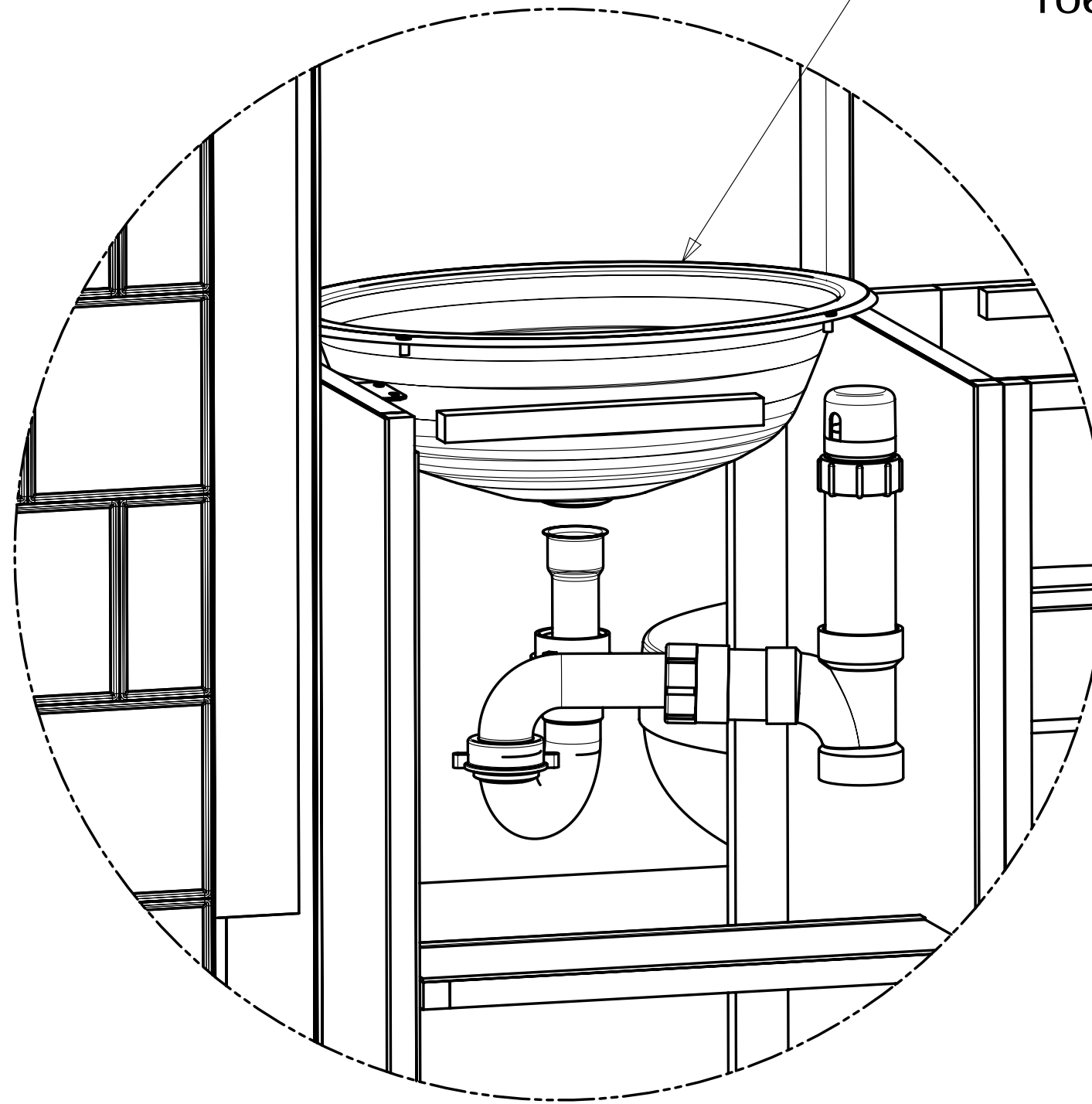

DETAIL DB
(SEE TAB)

FIRST USED	14 331H	
DO NOT SCALE DRAWING		
TITLE: DRAINAGE SYSTEM INSTL		
SHEET 4	PART NO 184744	REV

*A
*184744

DWG NO	DETAIL	DETAIL	DETAIL	MODEL
184749-01	BD	---	CE	231H
184749-02	BE	BF	CF	231HP

RELEASE	REV DATE	DWG NO	184749
REV ZONE	REVISION RECORD	DATE	DTR-ORIG

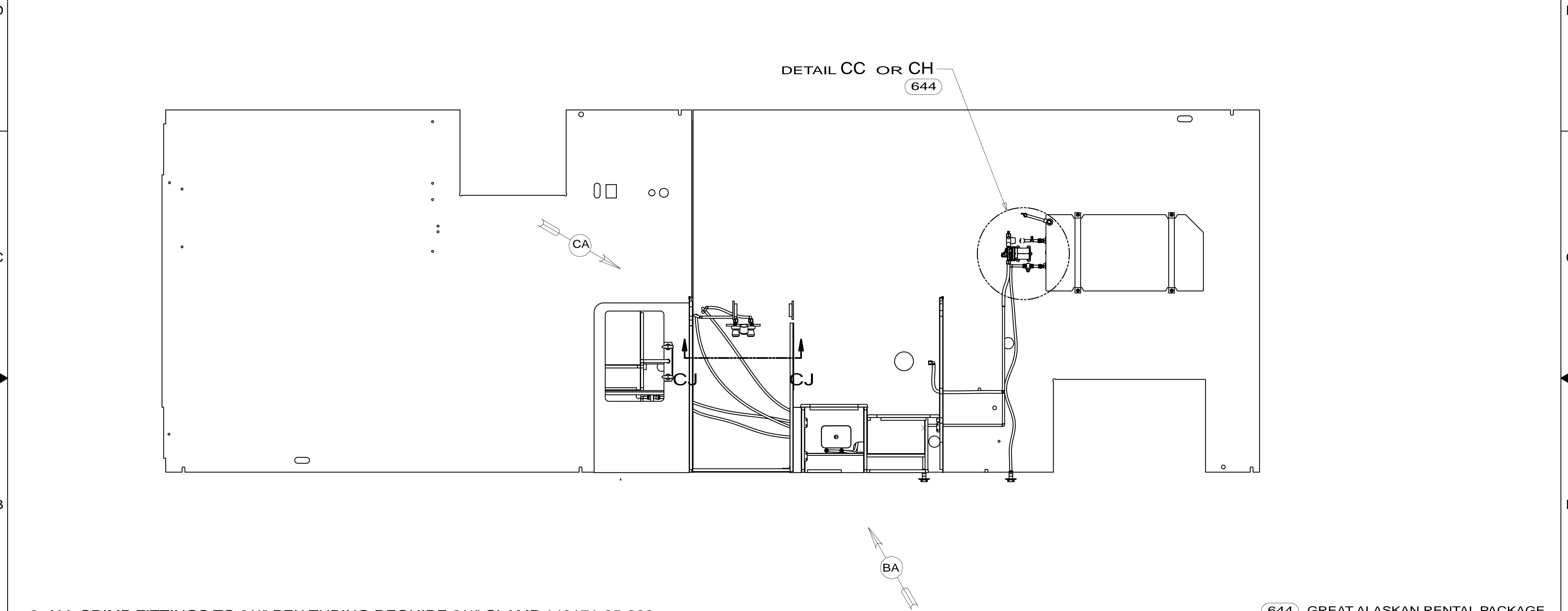

- 9. ALL CRIMP FITTINGS TO 3/4" PEX TUBING REQUIRE 3/4" CLAMP 140171-05-000.
- 8. ALL CRIMP FITTINGS TO 1/2" PEX TUBING REQUIRE 1/2" CLAMP 140171-03-000.
- 7. ALL CRIMP FITTINGS TO 5/8" FLEX TUBING REQUIRE 5/8" CLAMP 140171-04-000.
- 6 LABEL HOT AND COLD SUPPLY TUBES AND TAPE FITTING TO TUBE BEFORE CABINET SET TO PREVENT MOVEMENT.
- 5 ADD PIPE WRAP (LADDER SCRAP 110157-02-000) INSULATION.
- 4 ADD TEFLON TAPE 010405-02-000.
- 3. ALL TUBING TO BE SECURED AT 1200 INTERVALS MAXIMUM WITH CLAMP 010495-01-000 AND SCREW 000G67-10-12U OR EQUIVALENT.
- 2. TUBING TO BE INSTALLED WITH SUFFICIENT SLOPE TO PROVIDE DRAINAGE TO NEAREST VALVE.
- 1. PLASTIC FITTINGS TO BE SEALED WITH SEALANT 084456-01-000.

644 GREAT ALASKAN RENTAL PACKAGE

WINNEBAGO		COPYRIGHT 2014 WINNEBAGO INDUSTRIES, INC.	
DTR	ORIG. DATE	ALL DIMENSIONS ARE IN MILLIMETERS	
CHKR			
P.E.			
M.E.	FIRST USED		
DSNR		14 331H	
UNSPECIFIED TOLERANCES ARE:		MATERIAL:	
WHOLE DIM (X)	: 3		
ONE-PLACE (X.X)	: 1.5		
TWO-PLACE (X.XX)	: 0.50		
ANGLE	: 1°		
THIRD ANGLE PROJECTION			
DO NOT SCALE DRAWING		REFER TO ES0018 FOR FASTENER TIGHTENING GUIDELINES	
TITLE: WATER SYSTEM INSTL			
SHEET 1 OF 3	PART NO	184749	REV

FOR WATER CALLOUTS SEE DWG NO 116230-01-000

* 184749 * A

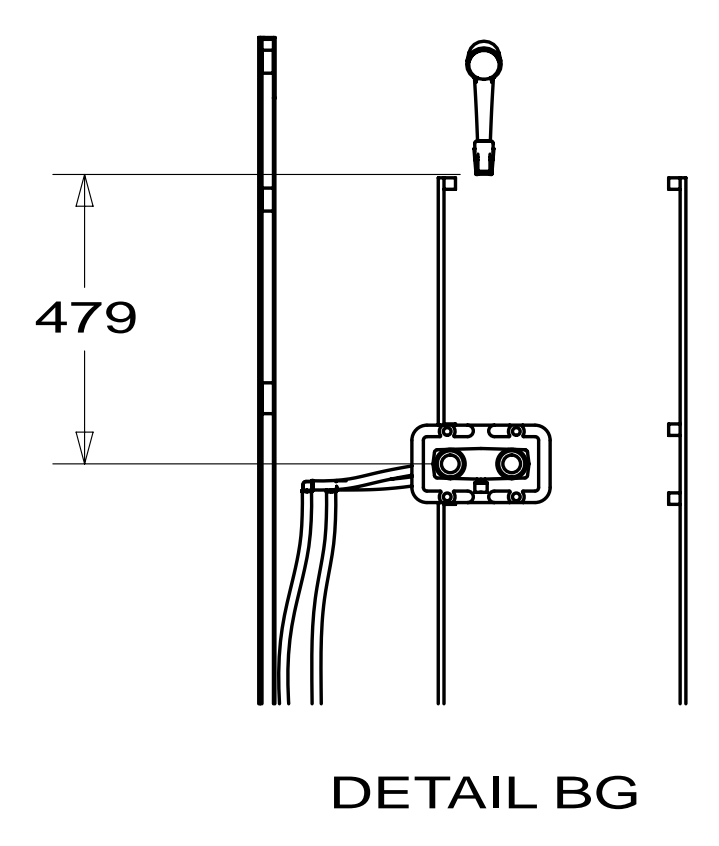
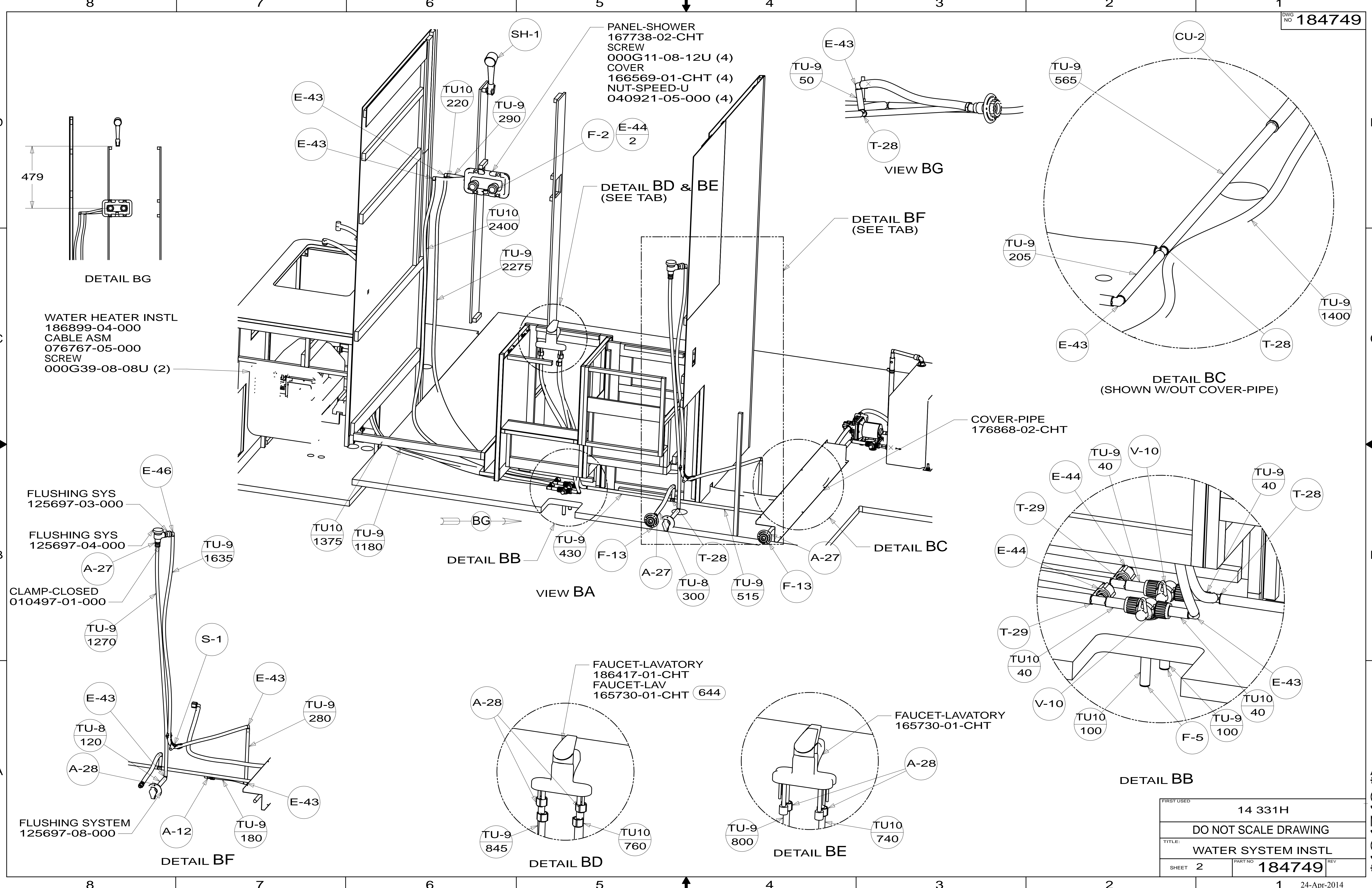

WATER HEATER INSTL
186899-04-000
CABLE ASM
076767-05-000
SCREW
000G39-08-08U (2)

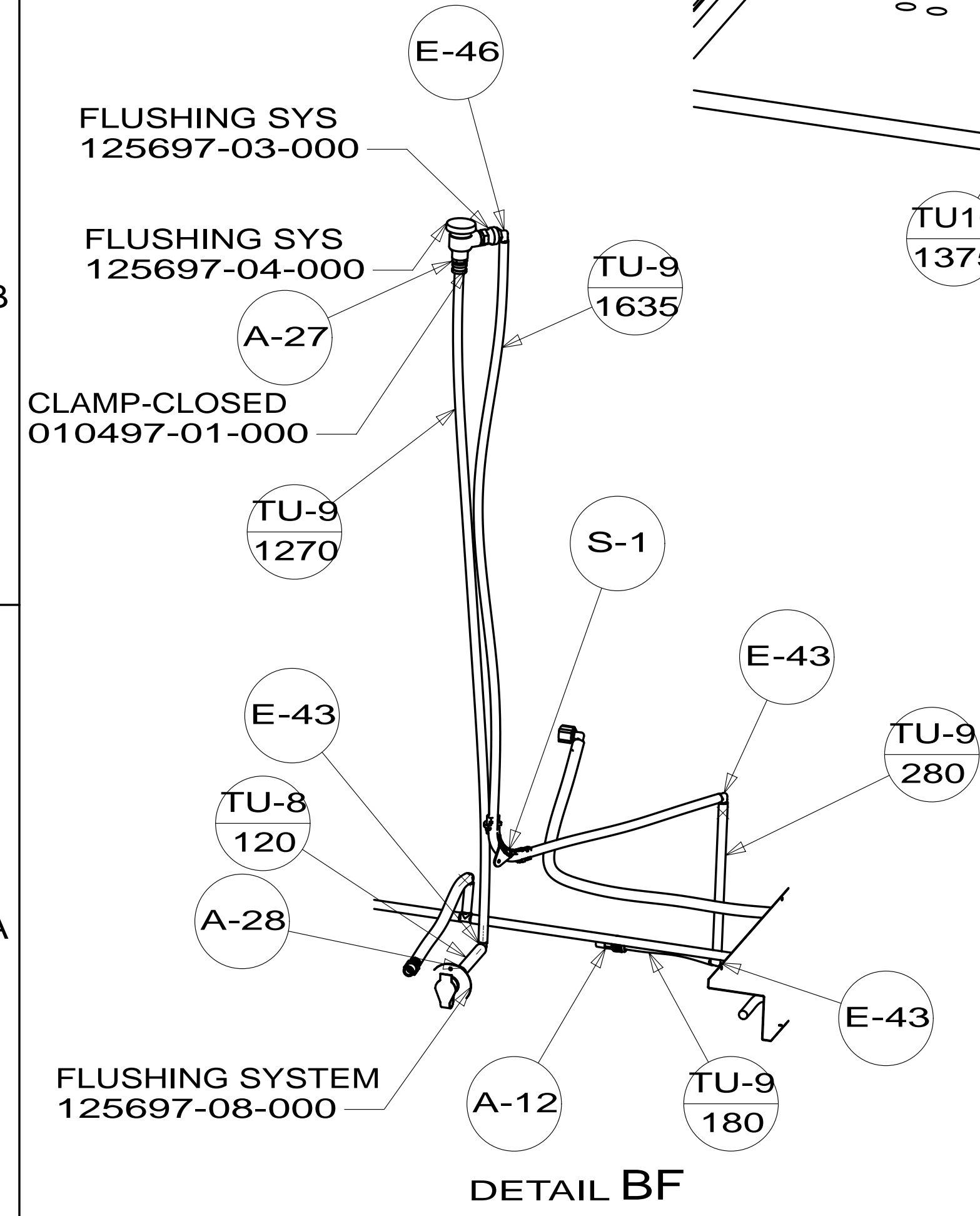

FLUSHING SYSTEM
125697-08-000

DETAIL BF

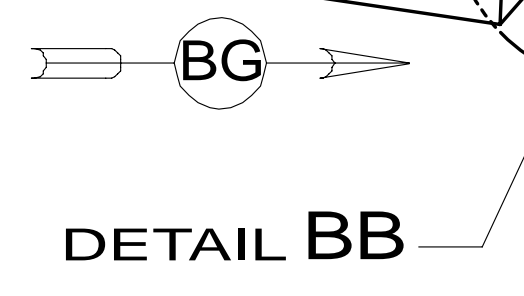

DETAIL BB

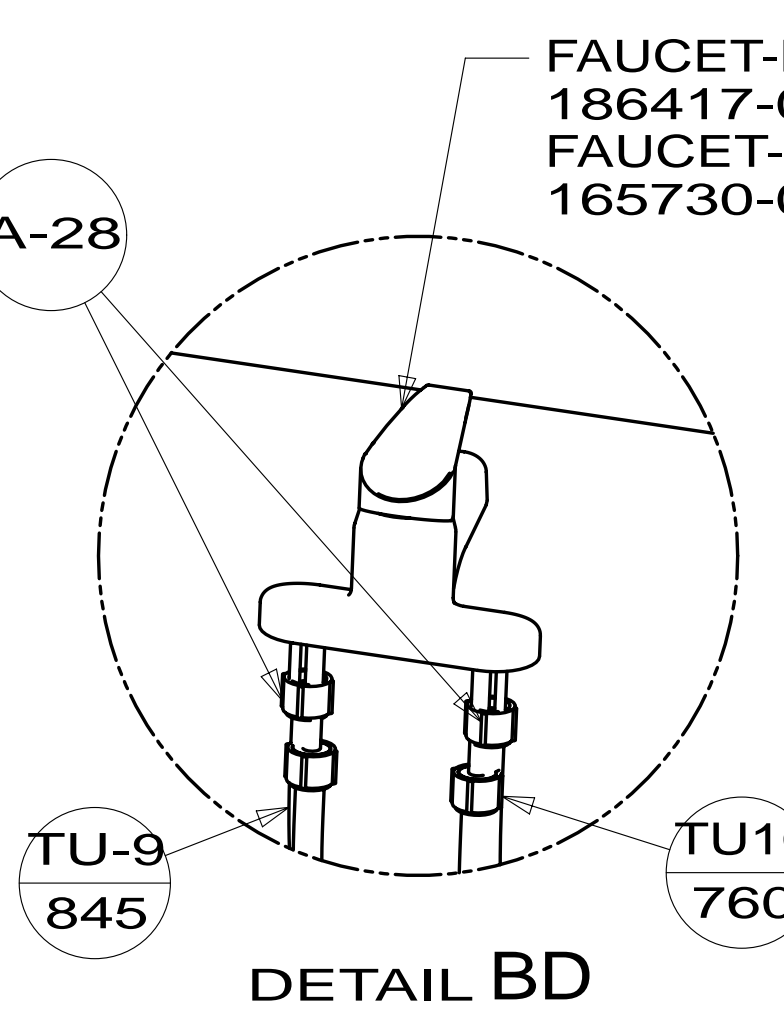

DETAIL BD

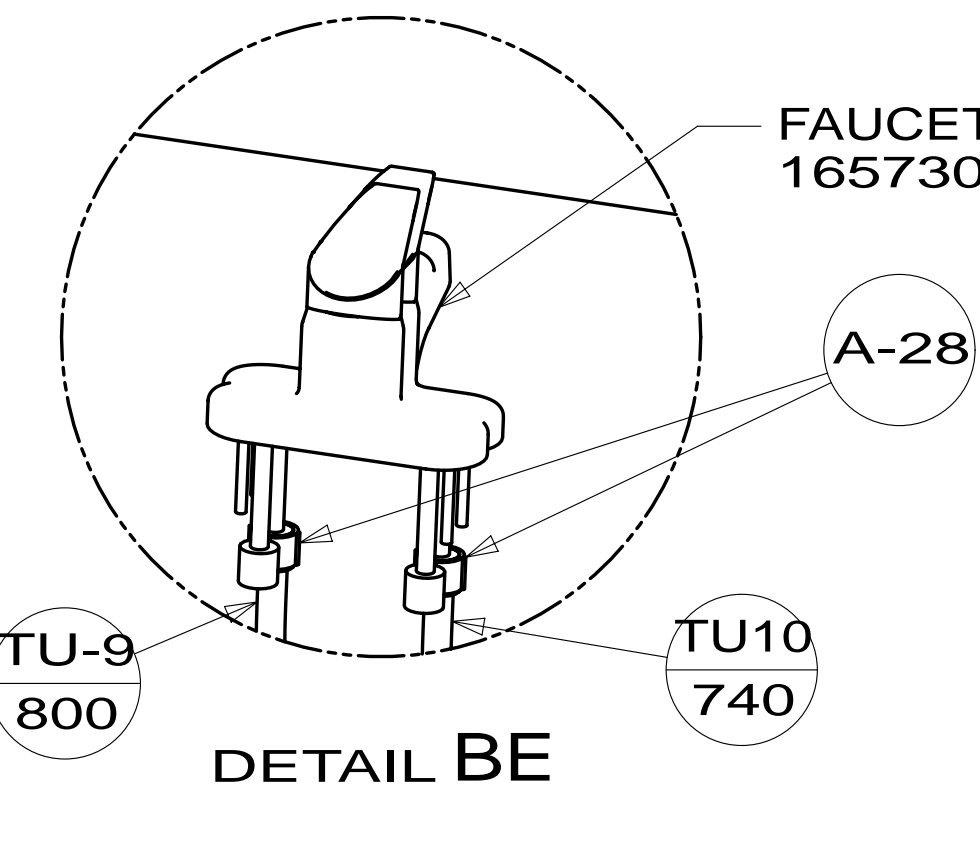

DETAIL BE

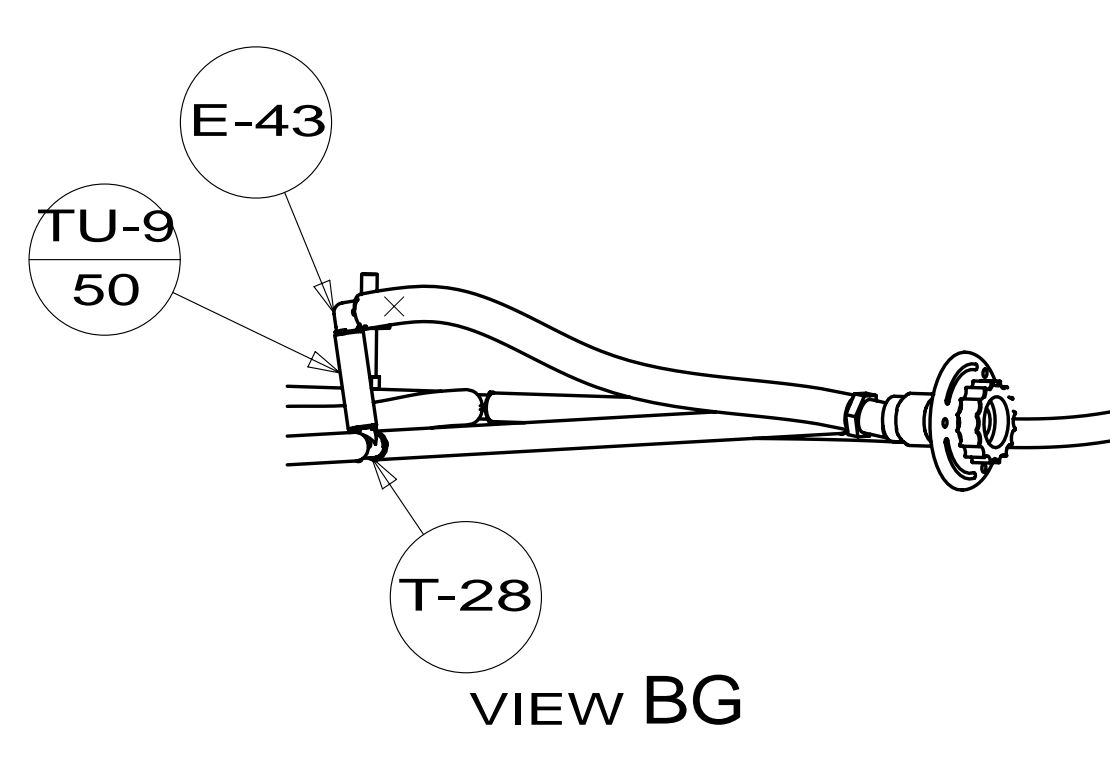

VIEW BG

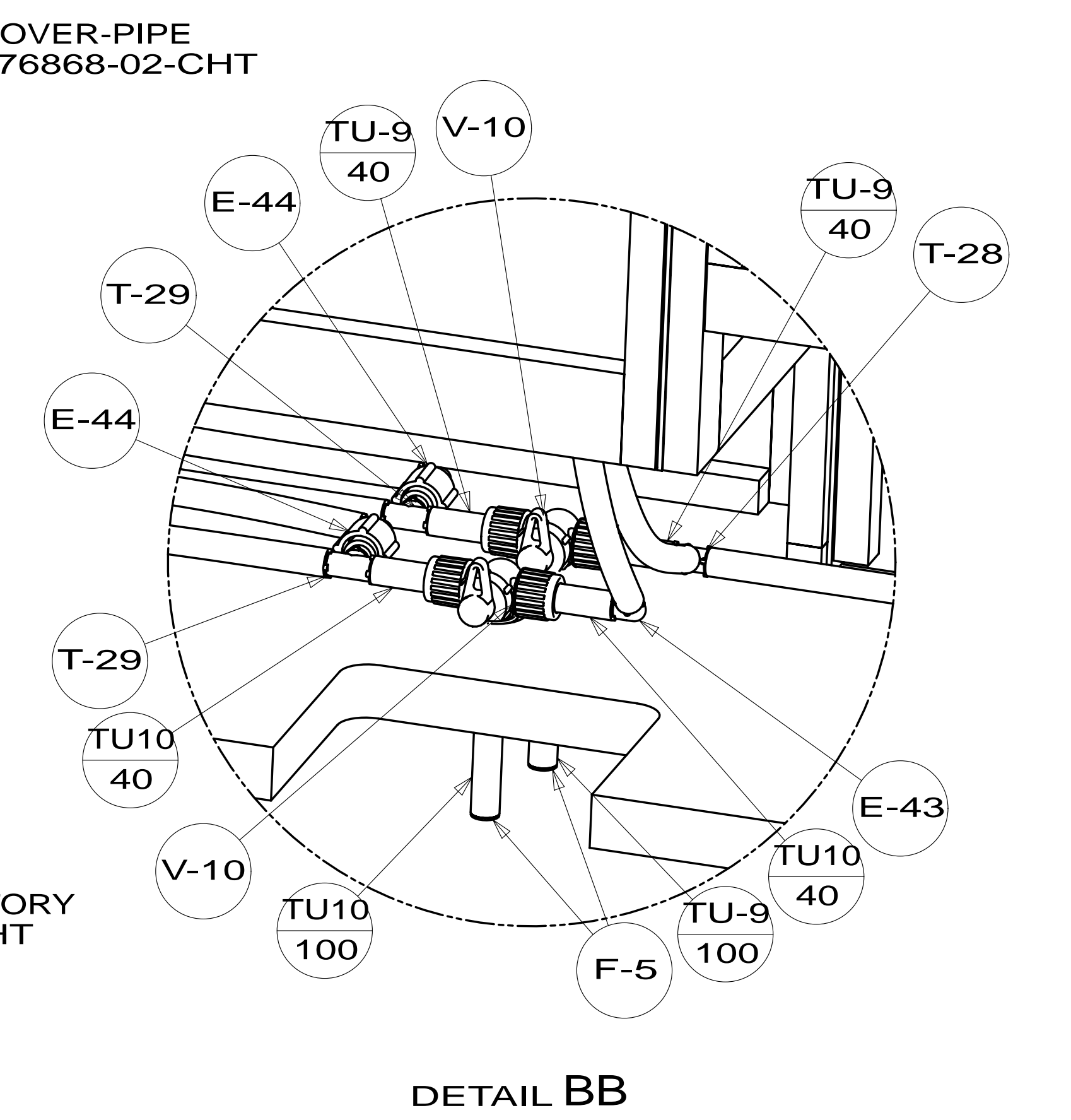

DETAIL BC

DETAIL BC
(SHOWN W/OUT COVER-PIPE)

COVER-PIPE
176868-02-CHT

FIRST USED	14 331H
DO NOT SCALE DRAWING	
TITLE: WATER SYSTEM INSTL	
SHEET 2	PART NO 184749 REV
24-Apr-2014	

*184749 *A

TANK ASM-WATER,47 GAL
 183814-02-000
 183814-03-000 (644)
 STRAP
 118994-10-CHT(2)
 WASHER
 000E13-16-00U(4)
 NUT
 000D39-05-00U(4)
 ELEVATOR BOLT
 000C18-05-40U(4)

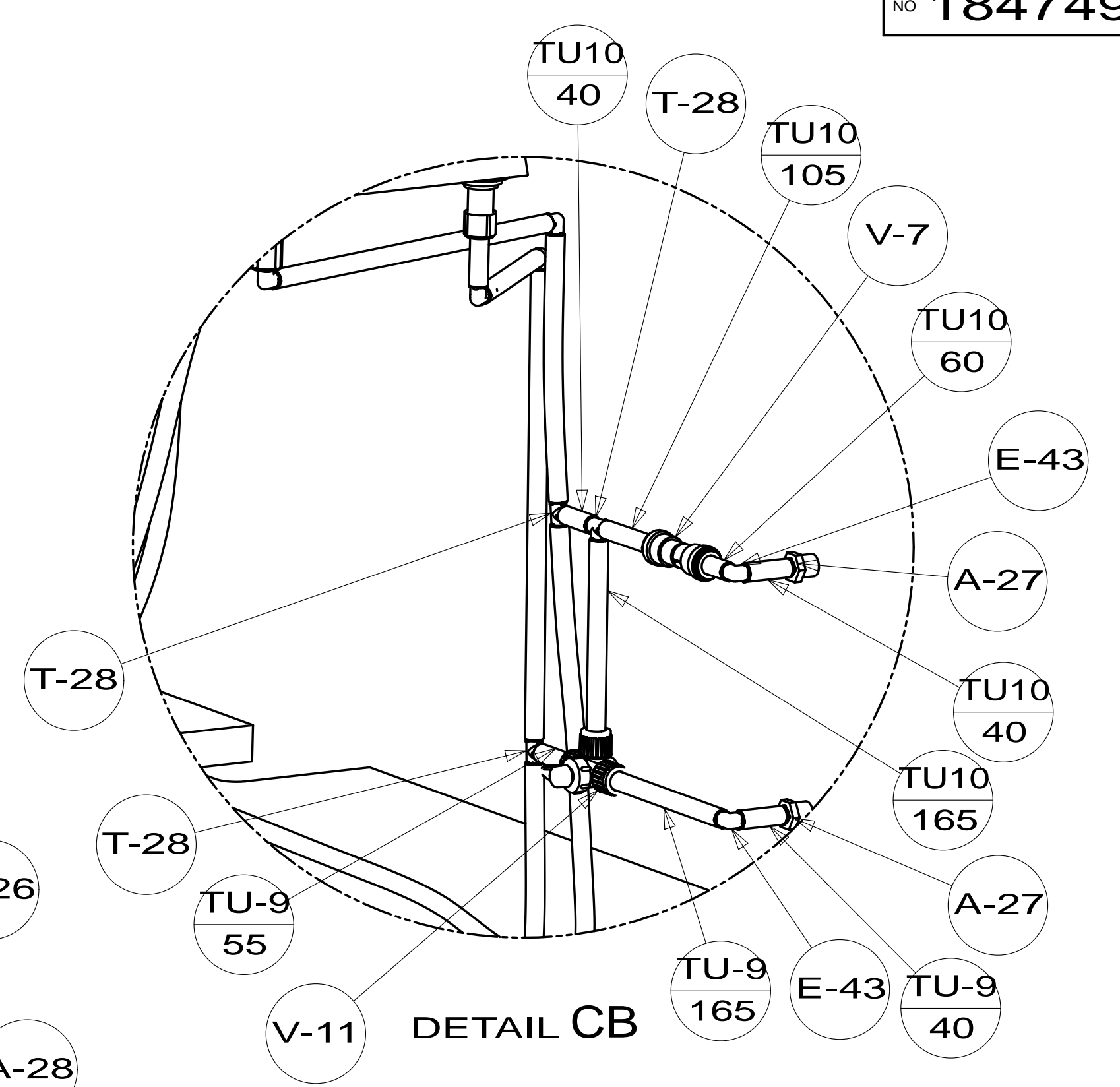
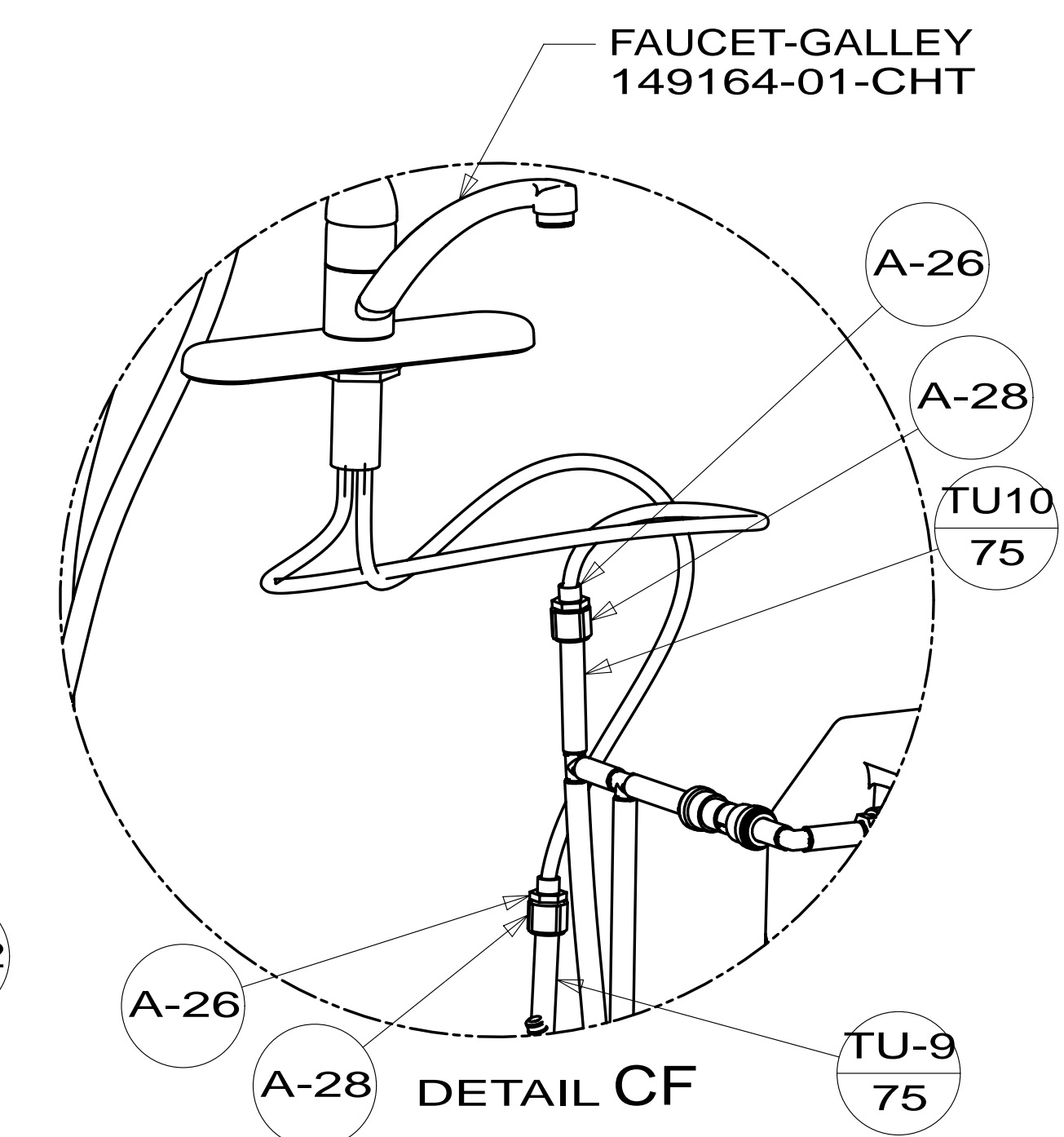
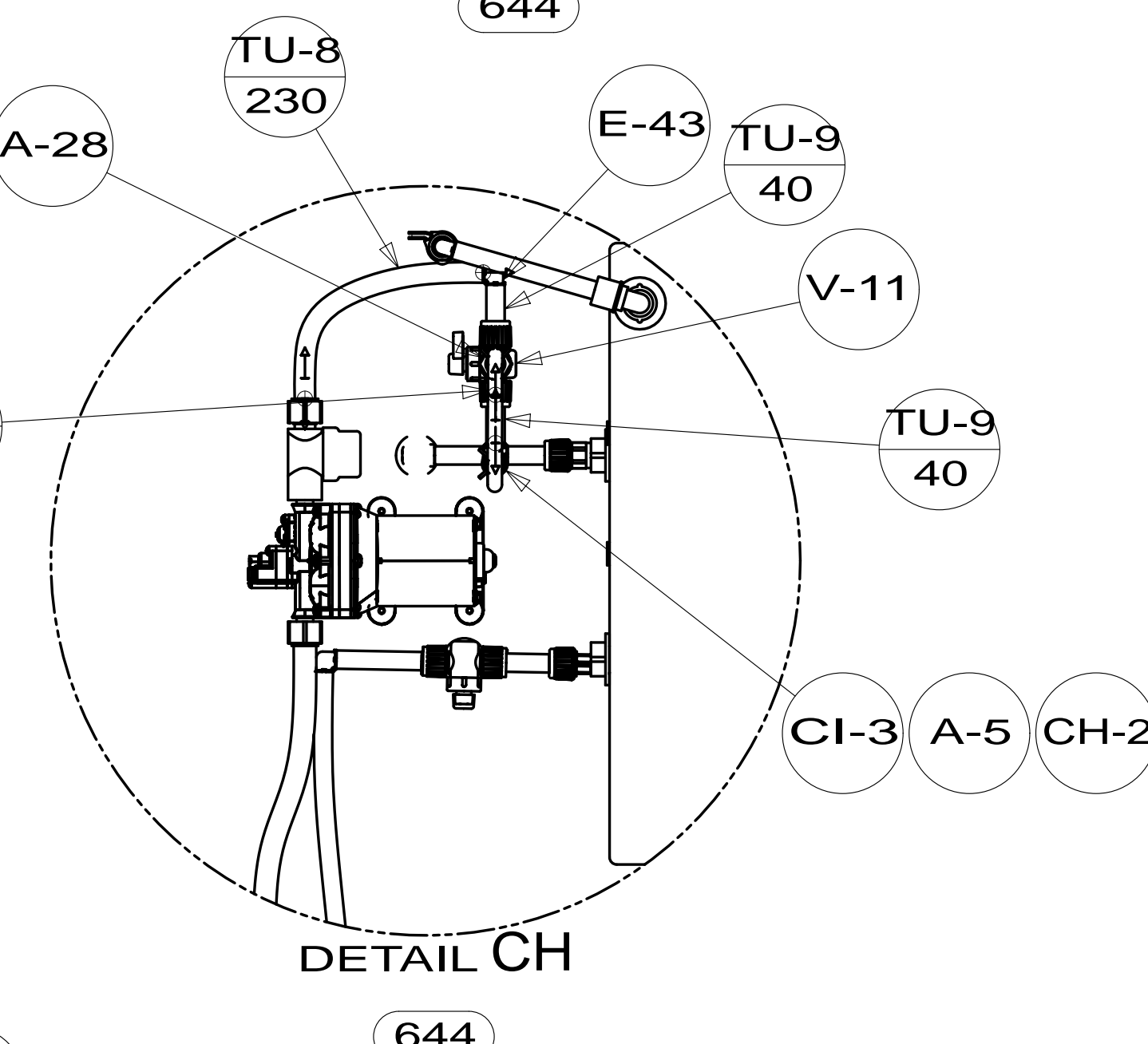
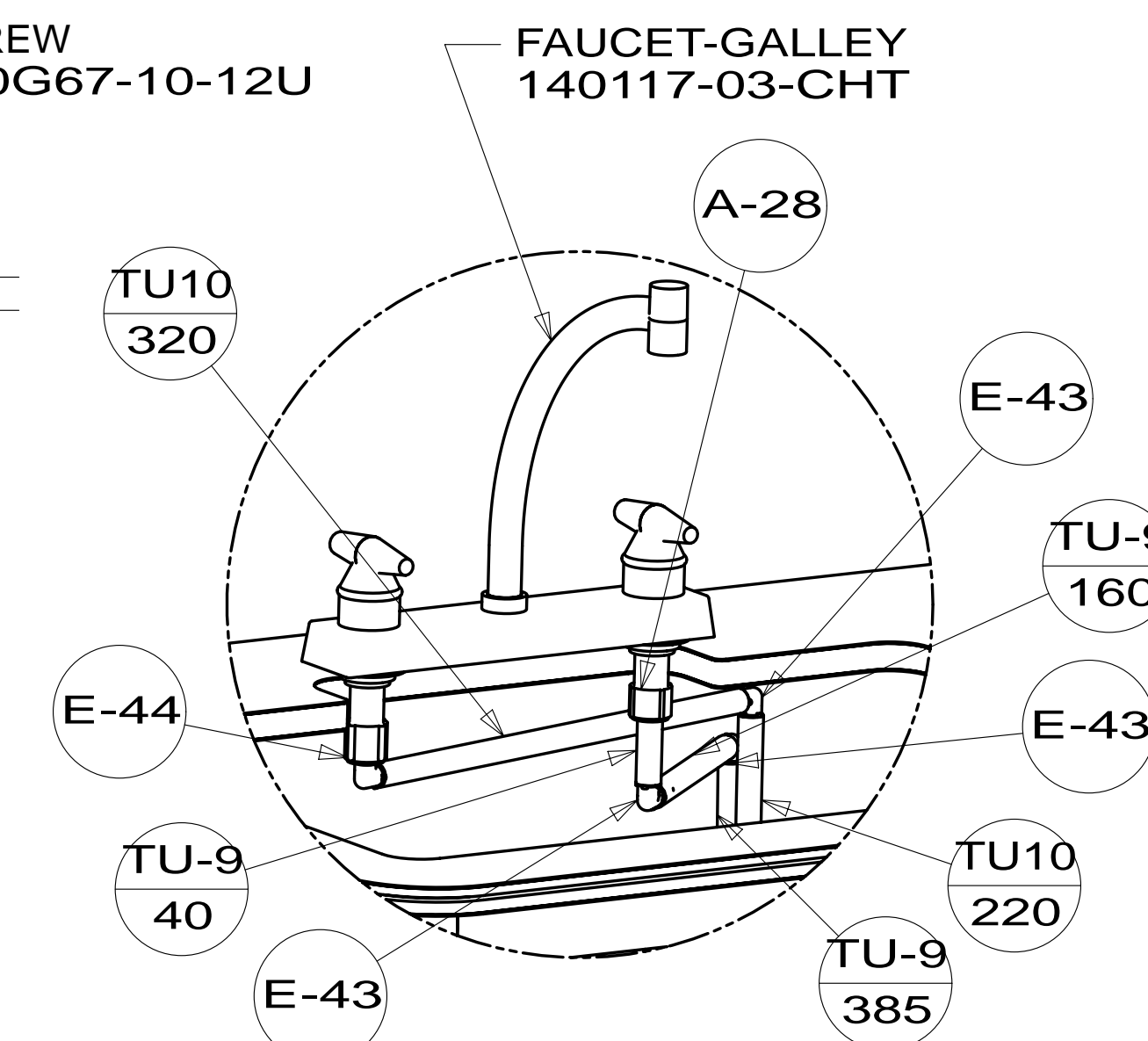
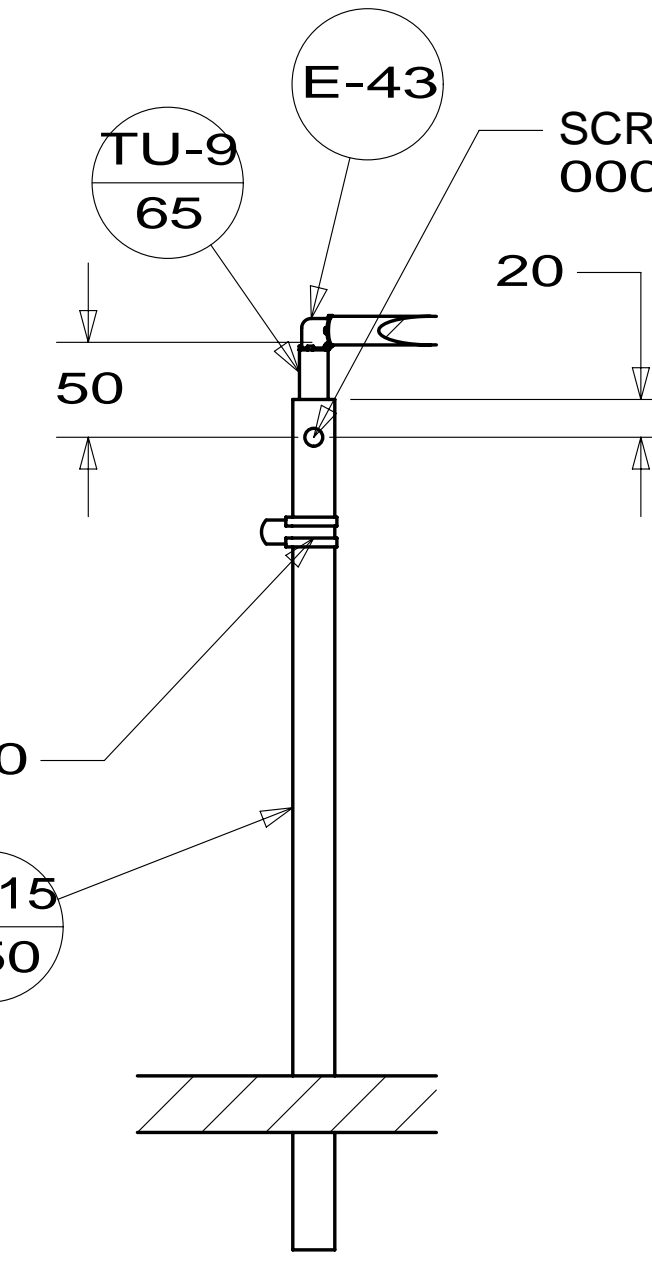
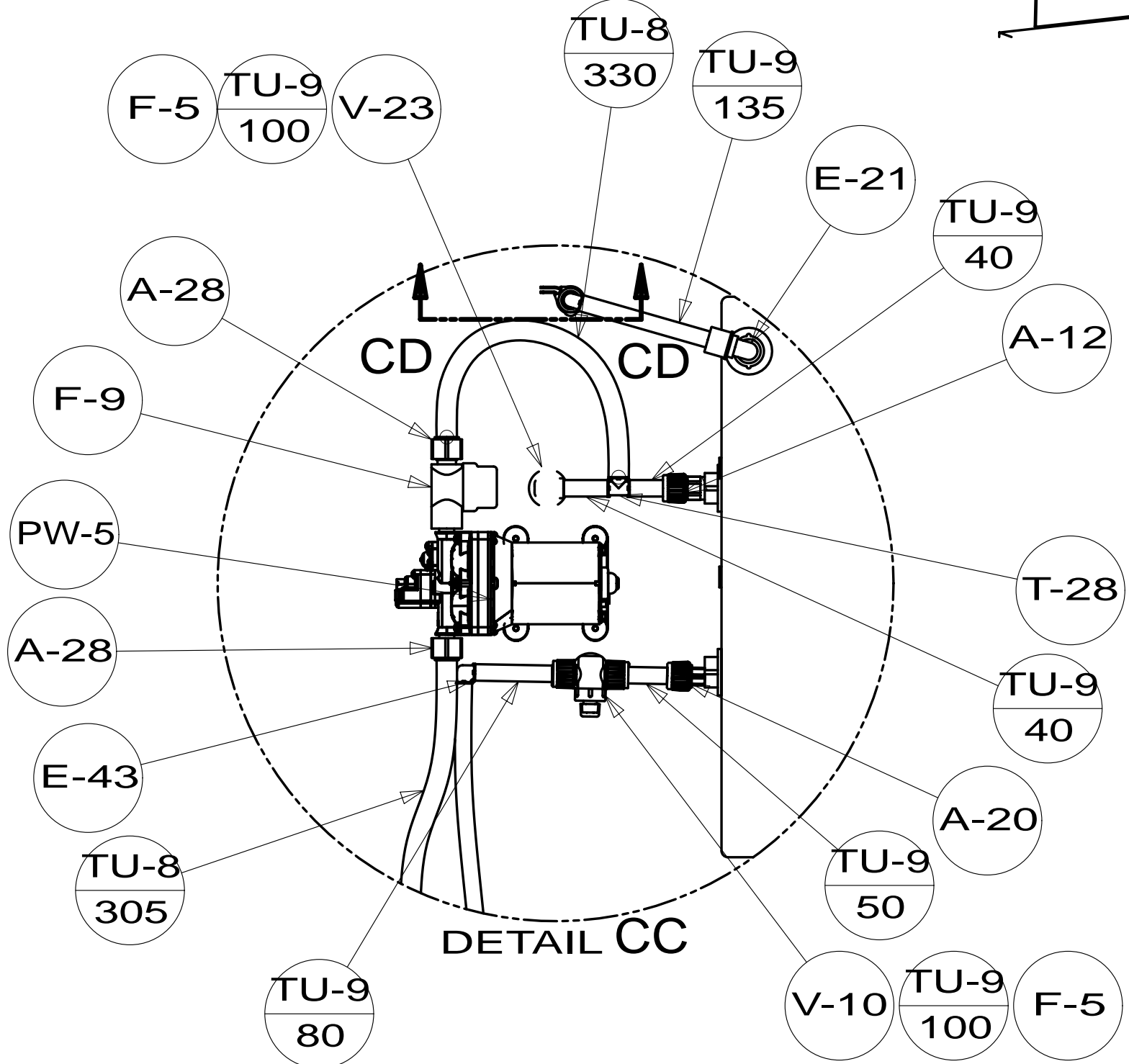
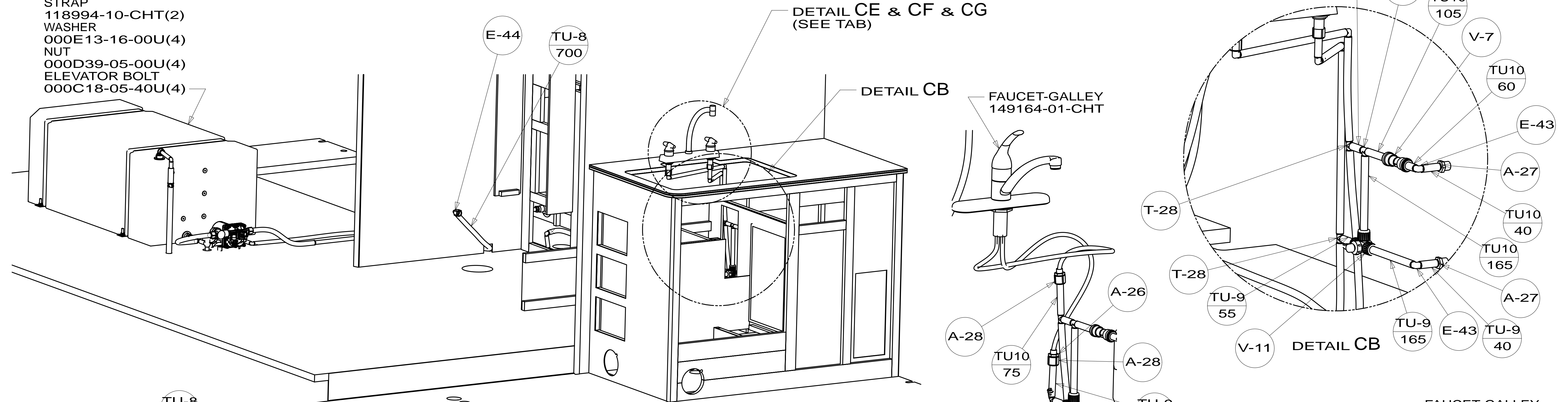

FIRST USED	14 331H	
TITLE:	DO NOT SCALE DRAWING	
SHEET 3	PART NO	184749
	REV	

24-Apr-2014

*184749 *A